

QUICK START GUIDE FOR DEMONSTRATION CIRCUIT 970A

HIGH EFFICIENCY, 500mA BUCK PLUS 300mA VLDO REGULATOR

LTC3541EDD/LTC3541EDD-1

DESCRIPTION

DC970A-A/B featuring the LTC3541/LTC3541-1 provides a high efficiency, 500mA synchronous buck plus 300mA VLDO regulator. The DC970A has an input voltage range of 3.0V to 5.5V. The jumper selectable 2.5V/1.8V output is capable of delivering up to 500mA of output current; the jumper selectable 0.8V/1.2V/1.5V/1.8V output is capable of delivering up to 300mA of current. The synchronous buck converter provides a high efficiency output, typically 90% while switching at 2.25MHz, allowing the use of small surface mount inductor and capacitors. In Burst Mode operation, the LTC3541 /LTC3541-1's low quiescent current results in high efficiency at light load currents. In Pulse Skip mode, the DC970A provides

lower output ripple voltage at light load currents than in Burst Mode. In either mode, the DC970A can provide up to 95% efficiency and consumes less than 3uA in shutdown. The LTC3541 comes in a small 10-Pin DFN package, which has an exposed pad on the bottom-side of the IC for good thermal performance. These features make the DC970 demo board an ideal reference circuit for battery-powered, hand-held applications.

Design files for this circuit board are available. Call the LTC factory.

LTC is a trademark of Linear Technology Corporation

Table 1. Performance Summary ($T_A = 25^\circ\text{C}$)

PARAMETER	CONDITION	VALUE
DC970A-A	Buck output Vout1 rise ahead of LDO Vout2	IC: LTC3541
DC970A-B	LDO output Vout2 rise ahead of Buck Vout1	IC: LTC3541-1
Input Voltage range	$V_{IN} \cdot V_{out2} + 1.4V$	3V-5.5V
Output Voltage V_{OUT1}	$V_{IN} = 3V \text{ to } 5.5V, I_{OUT1} = 0A \text{ to } 500mA$	1.8V / 2.5V $\pm 2\%$
Typical Output Ripple V_{OUT1}	$V_{IN} = 4.5V, I_{OUT1} = 500mA$ (20MHz BW)	20mVp-p
Output Voltage V_{OUT2}	$V_{IN} = 3V \text{ to } 5.5V, I_{OUT2} = 0A \text{ to } 300mA$	0.8V $\pm 2\%$ 1.2V $\pm 2\%$ 1.5V $\pm 2\%$ 1.8V $\pm 2\%$
Typical Output Ripple V_{OUT2}	$V_{IN} = 4.5V, I_{OUT2} = 300mA$ (20MHz BW)	10mVp-p
Nominal Switching Frequency		2.25MHz

QUICK START PROCEDURE

Demonstration circuit 970A is easy to set up to evaluate the performance of the LTC3541. Refer to Figure 1 for proper measurement equipment setup and follow the procedure below.

Note: When measuring the input or output voltage ripple, care must be taken to avoid a long ground lead on the oscilloscope probe. Measure the input or output voltage ripple by touching the probe tip directly across the Vin or Vout and GND terminals. See Figure 2 for proper scope probe technique.

1. Connect the input power supply to the Vin and GND terminals on the left-side of the board. Do not hot-plug Vin or increase Vin over the rated maximum supply voltage of 5.5V. Connect the loads between the Vout and GND terminals on the right-side of the board. Refer to Figure 1 for the proper measurement equipment setup.
2. Minimum operating V_{IN} voltage required for VLDO regulator and linear regulator regulation is:
 $V_{IN} \cdot V_{out2} + 1.4V$ and $V_{IN} \cdot 3.0V$.
3. Before proceeding to operation, insert jumpers JP5 and JP7 into the OFF positions, jumper **JP1-JP4** into the **Vout2** voltage position of choice (0.8V, 1.2V, 1.5V, and 1.8V), jumper **JP8** into the **Vout1** voltage position of choice (1.8V and 2.5V) and jumper **JP6** into the desired mode of operation: Pulse Skip or Burst Mode.
4. Set **JP9** in V_{out1} position. In some rare applications, if external input for VLDO is desired, set JP9 to LVIN_EXT. Check datasheet for more detailed usage of external input for VLDO.
5. Apply 3.3V at Vin. Measure both Vouts; they should read 0V. The supply current will be less than 3uA in shutdown condition.
6. Turn on Vout1 and Vout2 by changing jumpers JP5 and JP7 from the OFF position(s) to the ON position(s). Vary the input voltage from 3V to 5.5V and check output voltage. Both output voltages should be regulating. The regulated error should be less than 2% of rated voltage. In non load burst mode with both Buck (Vout1) and VLDO (Vout2) enabled the input current should be less than 70uA.
7. Set the load current of outputs between 25% to 100% load range, and measure both output ripple voltages; they should measure less than 20mV each. **Please note, the maximum load on Vout1 is 500mA minus load on Vout2.** The switching frequencies should be between 1.8MHz and 2.7MHz.
8. Jumper **default** position: (total of 6 jumpers needed)

JP9	JP8	JP7	JP6	JP5	JP1-JP4
Vout1	1.8V	ON	BURST	ON	1.2V

QUICK START GUIDE FOR DEMONSTRATION CIRCUIT 970A

HIGH EFFICIENCY, 500mA BUCK PLUS 300mA VLDO REGULATOR

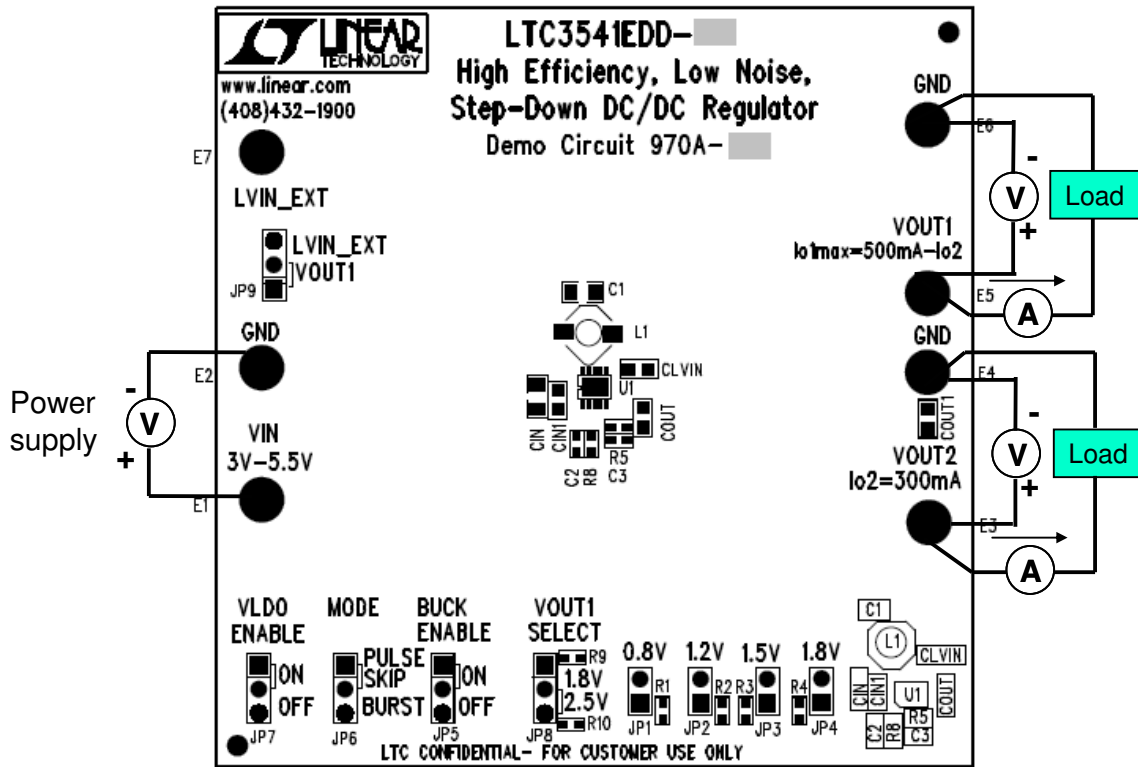

Figure 1. Proper Measurement Equipment Setup

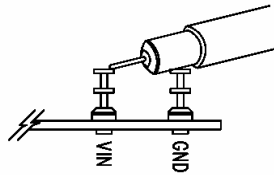

Figure 2. Scope Probe Placement for Measuring Input or Output Ripple

QUICK START GUIDE FOR DEMONSTRATION CIRCUIT 970A

HIGH EFFICIENCY, 500mA BUCK PLUS 300mA VLDO REGULATOR

* VERSION TABLE

ASSEMBLY TYPE	U1
DC970A-A	LTC3541EDD
DC970A-B	LTC3541EDD-1

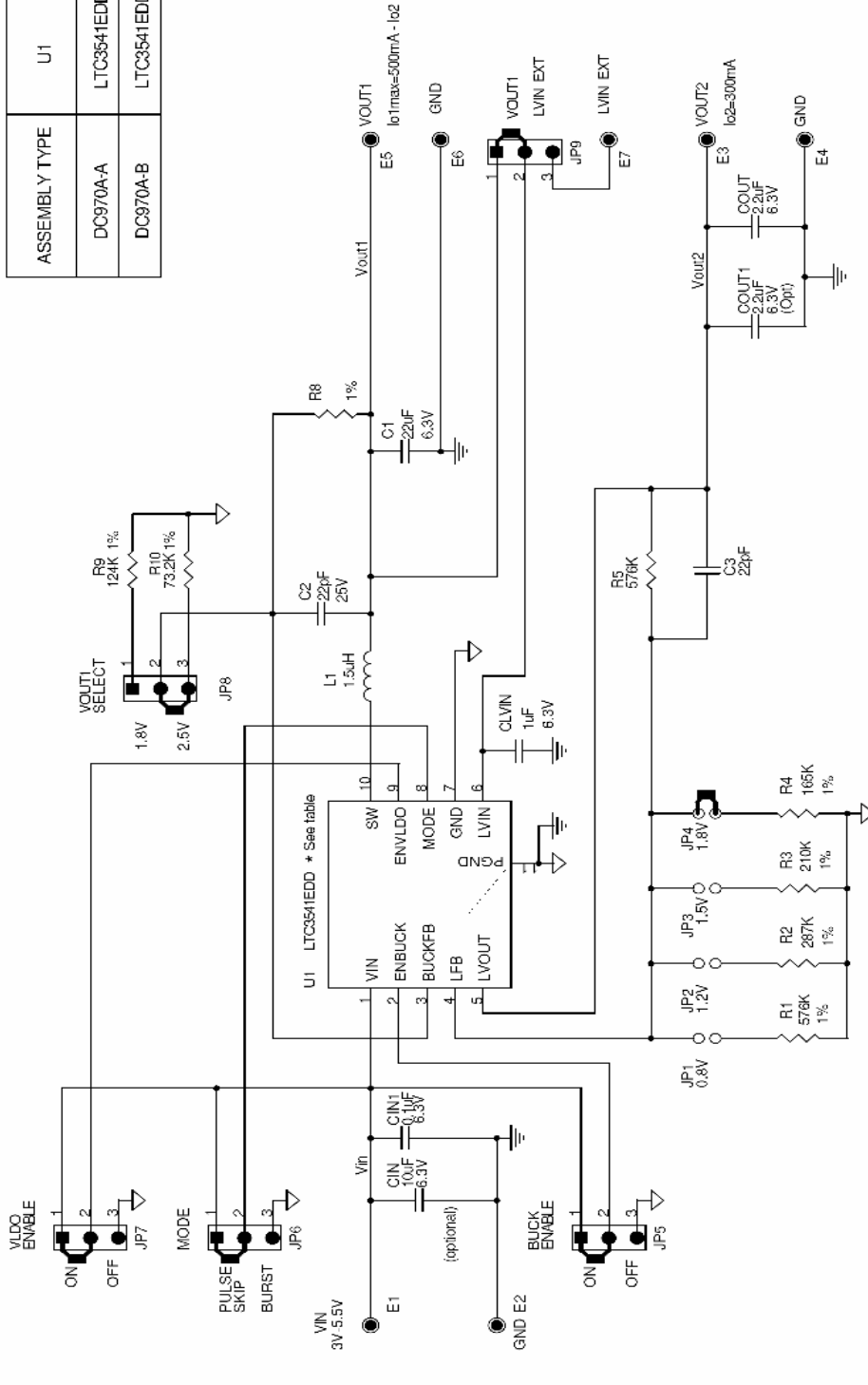

CUSTOMER NOTICE

LINEAR TECHNOLOGY HAS MADE A BEST EFFORT TO DESIGN A CIRCUIT THAT MEETS CUSTOMER-SUPPLIED SPECIFICATIONS; HOWEVER, IT REMAINS THE CUSTOMER'S RESPONSIBILITY TO VERIFY PROPER AND RELIABLE OPERATION IN THE ACTUAL APPLICATION. COMPONENT SUBSTITUTION AND PRINTED CIRCUIT BOARD LAYOUT MAY SIGNIFICANTLY AFFECT CIRCUIT PERFORMANCE OR RELIABILITY. CONTACT LINEAR TECHNOLOGY APPLICATIONS ENGINEERING FOR ASSISTANCE. THIS CIRCUIT IS PROPRIETARY TO LINEAR TECHNOLOGY AND SUPPLIED FOR USE WITH LINEAR TECHNOLOGY PARTS.

CONTRACTING:

APPROVALS	DATE
DRAWN: A. Harpova	10/28/05
CHECKED:	
APPROVED:	
ENGINEER: George Yu	10/28/05
DESIGNER:	

Friday, April 20, 2007

LINEAR TECHNOLOGY

16300A, Center Blvd
Milpitas, CA 95035
Phone: 408-262-9000
Fax: 408-262-5687

TITLE: LTC3541EDD/LTC3541EDD-1
High Efficiency, Low Noise, Step-Down DC/DC Regulator

SIZE	CAGE CODE	DWGNO	REV
			3

SCALE:	FILENAME:	SHEET	OF
		1	1