

3A Low Dropout Voltage Regulator

FEATURES

- Guaranteed 3A Output Current
- Three Terminal Adjustable or Fixed 1.5V, 1.8V, 2.5V, 3.3V and 5.0V
- Low Quiescent Current
- Low Dropout Voltage: 1.1V at 3A
- Line Regulation: 0.1%
- Load Regulation: 0.1%
- Stable with 10uF Ceramic Capacitor
- Overcurrent and Thermal Protection
- Similar to Industry Standard LT1085/LT1585
- Available in RoHS Compliant, Lead Free Packages: TO-252, TO-220, and TO-263

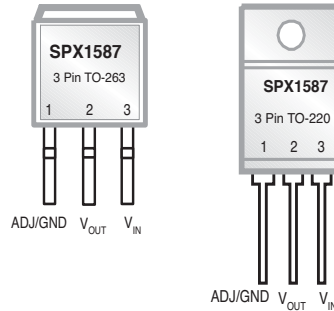

APPLICATIONS

- Desktop PC's Servers
- Powering VGA and Sound Cards
- Cordless Phones
- Battery Chargers
- Adjustable Power Supplies
- Portable Instrumentation
- SMPS Post-Regulator

DESCRIPTION

The SPX1587 is a low power positive-voltage regulator designed to satisfy moderate power requirements with a cost effective, small footprint solution. This device is an excellent choice for use in battery-powered applications and portable computers. The SPX1587 features very low quiescent current and a low dropout voltage of 1.1V at a full load. As output current decreases, quiescent current flows into the load, increasing efficiency. SPX1587 is available in adjustable or fixed 1.5V, 1.8V, 2.5V, 3.3V and 5.0V output voltages.

The SPX1587 is offered in several 3-pin surface mount packages: TO-252, TO-220 and TO-263. An output capacitor of 10µF ceramic or tantalum provides unconditional stability.

FUNCTIONAL DIAGRAM (Adjustable)

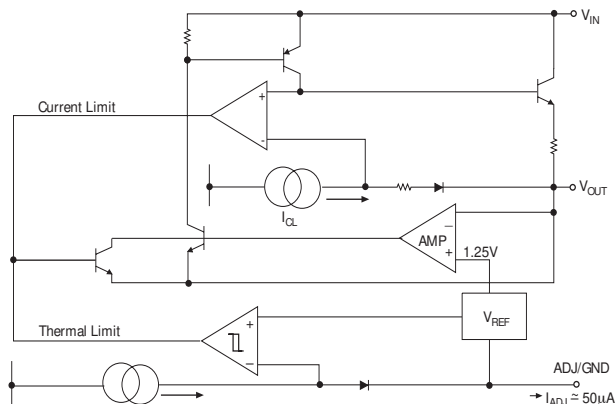

ABSOLUTE MAXIMUM RATINGS

Power Dissipation.....Internally Limited
 Lead Temperature (soldering, 5 seconds) 260°C
 Storage Temperature Range.....-65°C to +150°C

Operating Junction Temperature Range.....-40°C to +125°C
 Input Supply Voltage +10V
 Input to Output Voltage +8.8V
 ESD Rating 2kV min

ELECTRICAL CHARACTERISTICS

Specifications are at $V_{IN} = V_{OUT} + 1.5V$, $T_A = 25^\circ C$, $C_{IN} = C_{OUT} = 10\mu F$, $I_{OUT} = 10mA$, unless otherwise specified. The ♦ denotes the specifications which apply full operating temperature range -40°C to +85°C, unless otherwise specified.

PARAMETER	MIN	TYP	MAX	MIN	TYP	MAX	UNITS		CONDITIONS
1.5V Version	SPX1587A			SPX1587					
Output Voltage	1.485 1.470	1.500	1.515 1.530	1.470 1.455	1.500	1.530 1.545	V	♦	$I_{OUT} = 10mA$, $V_{IN} = 3.5V$ $10mA \leq I_{OUT} \leq 3A$, $3.0V \leq V_{IN} \leq 10V$
1.8V Version									
Output Voltage	1.782 1.764	1.800	1.818 1.836	1.764 1.746	1.800	1.836 1.854	V	♦	$I_{OUT} = 10mA$, $V_{IN} = 3.8V$ $10mA \leq I_{OUT} \leq 3A$, $3.3V \leq V_{IN} \leq 10V$
2.5V Version									
Output Voltage	2.475 2.450	2.500	2.525 2.550	2.450 2.425	2.500	2.550 2.575	V	♦	$I_{OUT} = 10mA$, $V_{IN} = 4.5V$ $10mA \leq I_{OUT} \leq 3A$, $4.25V \leq V_{IN} \leq 10V$
3.3V Version									
Output Voltage	3.267 3.234	3.300	3.333 3.366	3.234 3.201	3.300	3.366 3.399	V	♦	$I_{OUT} = 10mA$, $V_{IN} = 5V$ $10mA \leq I_{OUT} \leq 3A$, $4.75V \leq V_{IN} \leq 10V$
5.0V Version									
Output Voltage	4.950 4.900	5.000	5.050 5.100	4.900 4.850	5.000	5.100 5.150	V	♦	$I_{OUT} = 10mA$, $V_{IN} = 7V$ $10mA \leq I_{OUT} \leq 3A$, $6.50V \leq V_{IN} \leq 10V$
All Voltage Options									
Reference Voltage	1.238 1.225	1.250	1.262 1.275	1.225 1.212	1.250	1.275 1.287	V	♦	$I_{OUT} = 10mA$, $(V_{IN} - V_{OUT}) = 2V$ $10mA \leq I_{OUT} \leq 3A$, $1.5V \leq (V_{IN} - V_{OUT}) \leq 10V$
Output Voltage Temperature Stability		0.3			0.5		%		
Line Regulation		0.1 0.1 0.1 0.1 0.1	0.2 0.2 0.2 0.2 0.2		0.1 0.1 0.1 0.1 0.1	0.2 0.2 0.2 0.2 0.2	%		$3.0V \leq V_{IN} \leq 10V$, $V_{OUT} = 1.5V$ $3.3V \leq V_{IN} \leq 10V$, $V_{OUT} = 1.8V$ $4.25V \leq V_{IN} \leq 10V$, $V_{OUT} = 2.5V$ $4.75V \leq V_{IN} \leq 10V$, $V_{OUT} = 3.3V$ $6.50V \leq V_{IN} \leq 10V$, $V_{OUT} = 5.0V$
Load Regulation		0.1 0.1 0.1 0.1 0.1	0.3 0.3 0.3 0.3 0.3		0.1 0.1 0.1 0.1 0.1	0.3 0.3 0.3 0.3 0.3	%		$10mA \leq I_{OUT} \leq 3A$, $V_{OUT} = 1.5V$ $10mA \leq I_{OUT} \leq 3A$, $V_{OUT} = 1.8V$ $10mA \leq I_{OUT} \leq 3A$, $V_{OUT} = 2.5V$ $10mA \leq I_{OUT} \leq 3A$, $V_{OUT} = 3.3V$ $10mA \leq I_{OUT} \leq 3A$, $V_{OUT} = 5.0V$
Dropout Voltage (Note 2)		1.00 1.05 1.10			1.00 1.05 1.10		V		$I_{OUT} = 1A$ $I_{OUT} = 2A$ $I_{OUT} = 3A$
Minimum Load Current (Note 4)		4	10		4	10	mA		
Quiescent Current		4	10		4	10	mA		Fixed voltage versions
Adjust Pin Current		50			50		µA	♦	
Current Limit	3.2	5		3.2	5		A		$(V_{IN} - V_{OUT}) = 2V$
Thermal Regulation		0.01	0.1		0.01	0.1	%/W		25°C, 30ms pulse
Ripple Rejection	60	75		60	75		dB		$F_{RIPPLE} = 120Hz$, $(V_{IN} - V_{OUT}) = 2V$, $V_{RIPPLE} = 1V_{PP}$
Long Term Stability		0.03			0.03		%		125°C, 1000Hrs
RMS Output Noise		0.003			0.003		%		% of V_{OUT} , 10Hz $\leq f \leq$ 10kHz
Thermal Resistance		3 29.4 3 31.4 6 50			3 29.4 3 31.4 6 50		°C/W		TO-220 Junction to Case, at Tab TO-220 Junction to Ambient TO-263 Junction to Case, at Tab TO-263 Junction to Ambient TO-252 Junction to Case, at Tab TO-252 Junction to Ambient

ELECTRICAL CHARACTERISTICS: Continued (Notes)

NOTES:

- Note 1: Output temperature coefficient is defined as the worst case voltage change divided by the total temperature range
- Note 2: Dropout voltage is defined as the input to output differential at which the output voltage drops 100mV below its nominal value measured at 1V differential at very low values of programmed output voltage, the minimum input supply voltage of 2V (2.3V over temperature) must be taken into account.
- Note 3: Thermal regulation is defined as the change in output voltage at a time T after a change in power dissipation is applied. excluding load or line regulation effect.
- Note 4: Adjustable Version Only.

TYPICAL PERFORMANCE CHARACTERISTICS

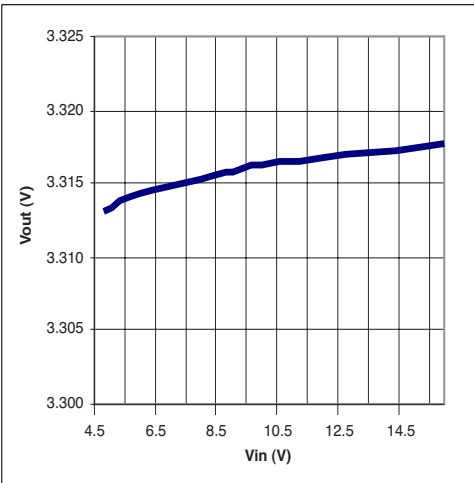

Figure 1. Line Regulation for SPX1587U-3.3; $I_{OUT}=10mA$

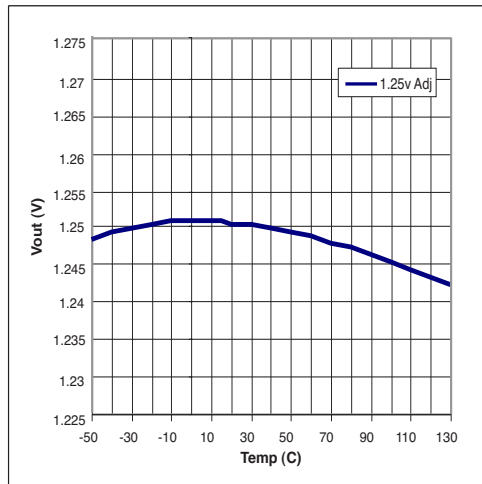

Figure 2. V_{OUT} vs Temperature, $V_{IN}=2.5V$, $I_{OUT}=10mA$

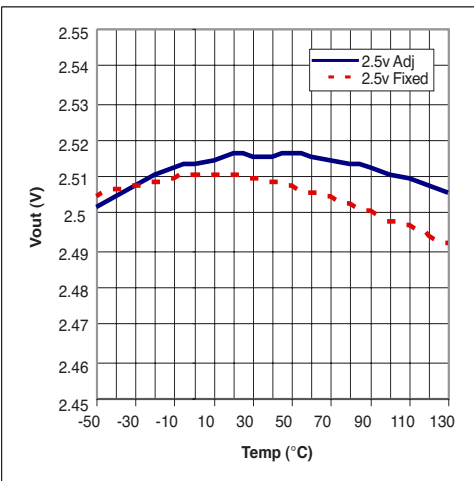

Figure 3. $V_{IN}=4.0V$, $I_{OUT}=10mA$

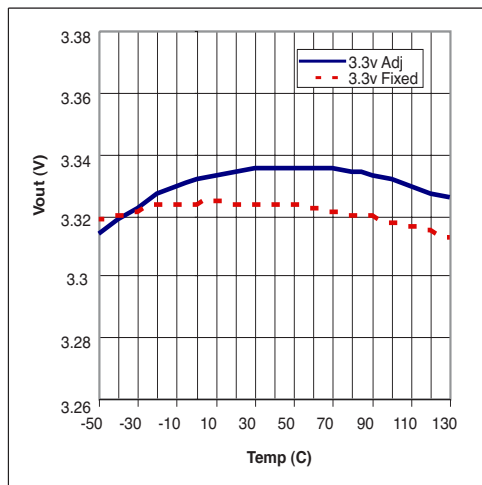

Figure 4. $V_{IN}=5.0V$, $I_{OUT}=10mA$

Output Capacitor

To ensure the stability of the SPX1587, an output capacitor of at least 10µF (ceramic or tantalum) or 22µF (aluminum) is required. The value may change based on the application requirements of the output load or temperature range. The value of ESR can vary based on the type of capacitor used in the applications to guarantee stability. The recommended value for ESR is 0.5Ω or less. A larger value of output capacitance (up to 100µF) can improve the load transient response.

Soldering Methods

The SPX1587 die is attached to the heatsink lead which exits opposite the input, output, and ground pins.

Thermal Characteristics

The SPX1587 features the internal thermal limiting to protect the device during overload conditions. Special care needs to be taken during continuous load conditions such that the maximum junction temperature does not exceed 125°C. Thermal protection is activated at >179°C and deactivated at <165 °C.

The thermal interaction from other components in the application can effect the thermal resistance of the SPX1587. The actual thermal resistance can be determined with experimentation.

SPX1587 power dissipation is calculated as follows:

$$P_D = (V_{IN} - V_{OUT})(I_{OUT})$$

Maximum Junction Temperature range:

$$T_J = T_A (\text{max}) + P_D * \theta_{JA}$$

(junction-to-ambient thermal resistance)

Maximum junction temperature must not exceed 125°C.

Ripple Rejection

Ripple rejection can be improved by adding a capacitor between the ADJ pin and ground as shown in Figure 8. When ADJ pin bypassing is used, the value of the output capacitor required increases to its maximum. If the ADJ pin is not bypassed, the value of the output capacitor can be lowered to 22µF for an electrolytic aluminum capacitor or 10µF for a solid tantalum capacitor (Fig 7).

However the value of the ADJ-bypass capacitor should be chosen with respect to the following equation:

$$C = 1 / (6.28 * F_R * R_1)$$

Where

C = value of the capacitor in Farads
(select an equal or larger standard value),
F_R = ripple frequency in Hz,
R₁ = value of resistor R1 in Ohms.

If an ADJ-bypass capacitor is used, the amplitude of the output ripple will be independent of the output voltage. If an ADJ-bypass capacitor is not used, the output ripple will be proportional to the ratio of the output voltage to the reference voltage:

$$M = V_{OUT} / V_{REF}$$

Where M = multiplier for the ripple seen when the ADJ pin is optimally bypassed.

$$V_{REF} = 1.25V$$

Ripple rejection for the adjustable version is shown in Figure 5.

Output Voltage

The output of the adjustable regulator can be set to any voltage between 1.25V and 15V. The value of V_{OUT} can be quickly approximated using the formula

$$V_{OUT} = 1.25 * (R_1 + R_2) / R_1$$

A small correction to this formula is required depending on the values of resistors R₁ and R₂, since the adjustable pin current (approx 50µA) flows through R₂. When I_{ADJ} is taken into account, the formula becomes

$$V_{OUT} = V_{REF} (1 + (R_2/R_1)) + I_{ADJ} * R_2$$

where

$$V_{REF} = 1.25V$$

Layout Considerations

Parasitic line resistance can degrade load regulation. In order to avoid this, connect R₁ directly to V_{OUT} as illustrated in Figure 13. For the same reason, R₂ should be connected to the negative side of the load.

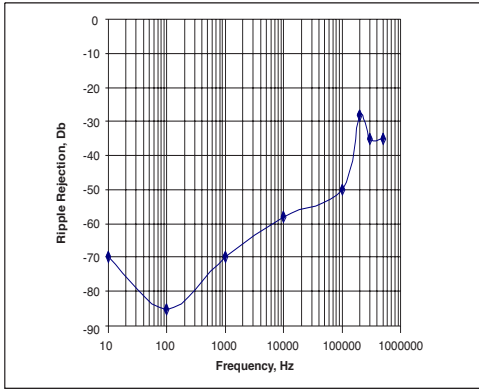

Figure 5. Ripple Rejection; $V_{in}=3.3V$, $V_{out}=1.8V$ (adj.), $I_{load}=200mA$

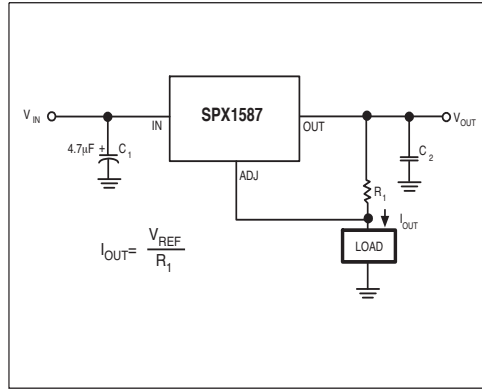

Figure 6. Current Source

$$I_{OUT} = \frac{V_{REF}}{R_1}$$

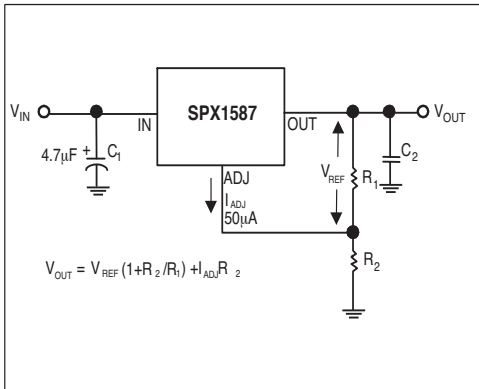

Figure 7. Typical Adjustable Regulator

$$V_{OUT} = V_{REF} (1 + R_2/R_1) + I_{ADJ} R_2$$

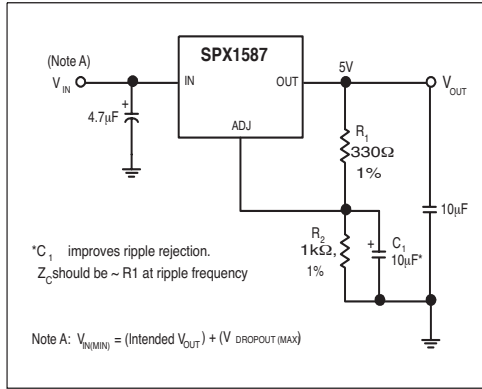

Figure 8. Improving Ripple Rejection

* C_1 improves ripple rejection.
 Z_c should be $\sim R_1$ at ripple frequency

Note A: $V_{IN(MIN)} = (\text{Intended } V_{OUT}) + (V_{DROPOUT(MAX)})$

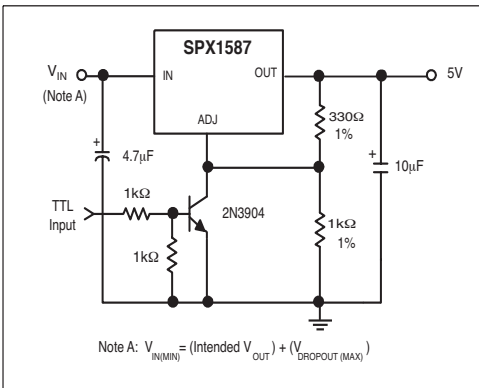

Figure 9. 5V Regulator with Shutdown

Note A: $V_{IN(MIN)} = (\text{Intended } V_{OUT}) + (V_{DROPOUT(MAX)})$

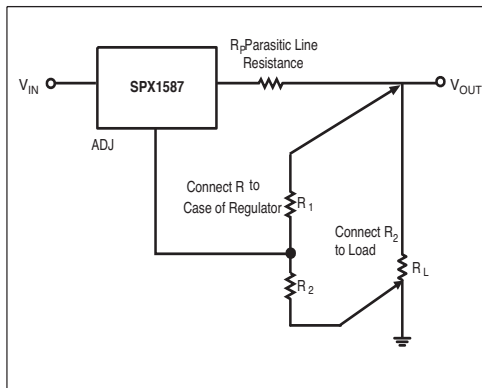
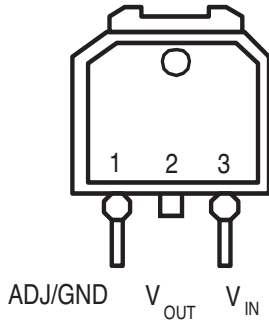

Figure 10. Recommended Connections for Best Results

Note that TAB is connected to V_{OUT} for all 3 package types.

TO-252 (R)



Front View

TO-220-3 (U)

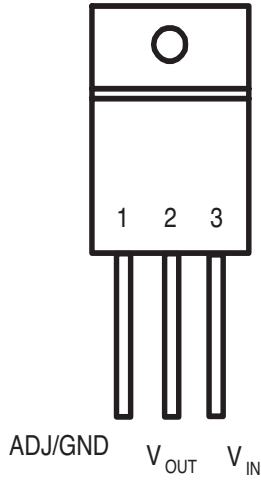

Front View

TO-263-3 (T)

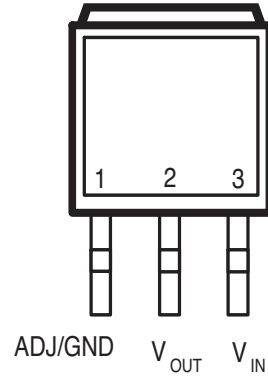

Top View

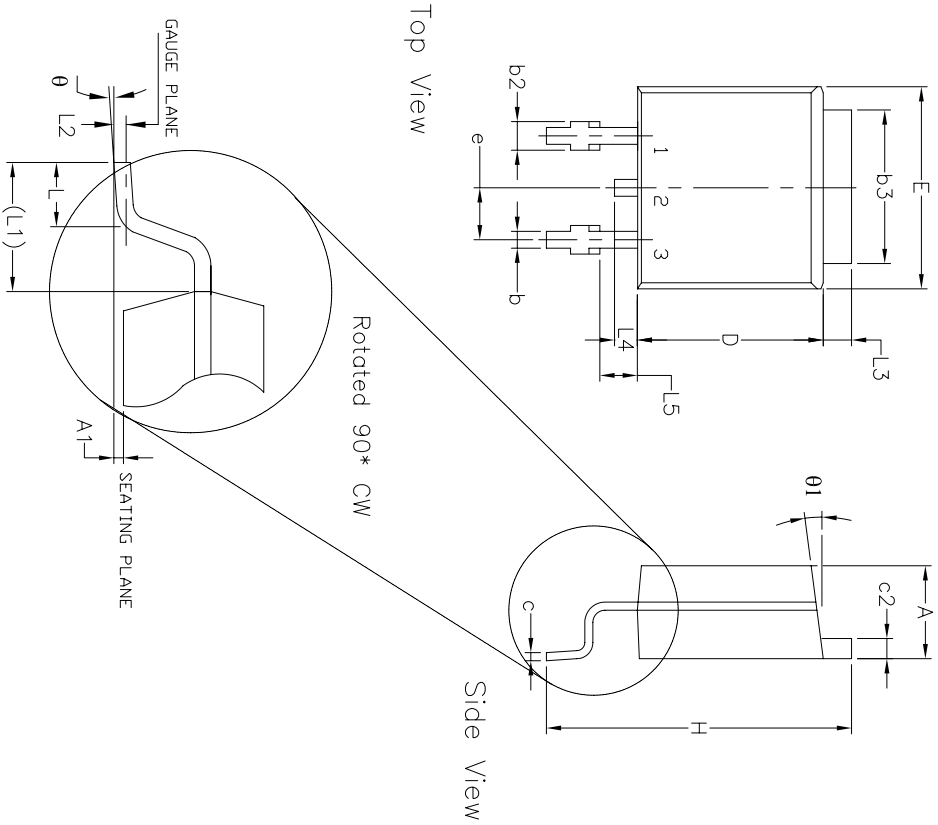

REVISION HISTORY			
REV.	DESCRIPTION	DATE	APP'D
A	DRAWING ORIGINATION	08/04/05	JL
B	DRAWING FORMAT MODIFICATION	09/14/06	JL

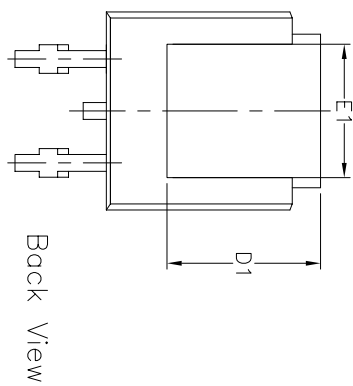

SYMBOLS	DIMENSIONS IN INCH (Control Unit)			DIMENSIONS IN MM (Reference Unit)		
	MIN.	NOM.	MAX.	MIN.	NOM.	MAX.
A	0.086	—	0.094	2.18	—	2.39
A1	—	—	0.003	—	—	0.13
b	0.025	—	0.035	0.64	—	0.89
b2	0.030	—	0.045	0.76	—	1.14
c	0.018	—	0.024	0.46	—	0.61
c2	0.035	—	0.035	0.46	—	0.89
D	0.235	0.240	0.245	5.97	6.10	6.22
D1	0.205	—	—	5.21	—	—
E	0.250	—	0.265	6.35	—	6.73
E1	0.170	—	—	4.32	—	—
H	—	0.090 BSC	—	—	2.29 BSC	—
H	0.370	—	0.410	9.40	—	10.41
L	0.055	0.060	0.070	1.40	1.52	1.78
L1	—	0.108 REF	—	—	2.74 REF	—
L2	—	0.020 BSC	—	—	0.51 BSC	—
L3	0.035	—	0.050	0.89	—	1.27
L4	—	—	0.040	—	—	1.02
L5	0.045	—	0.060	1.14	—	1.52
theta	0°	—	10°	0°	—	10°
theta1	0°	—	15°	0°	—	15°
N	—	3	—	—	3	—

SIPLEX CORPORATION

3 PIN TO-252 PACKAGE OUTLINE

By: JL	Date: 09/14/06	Revision: B	Sheet: 1 OF 1
--------	----------------	-------------	---------------

Packaging Approval: _____ Drawing No: 3-PIN TO-252

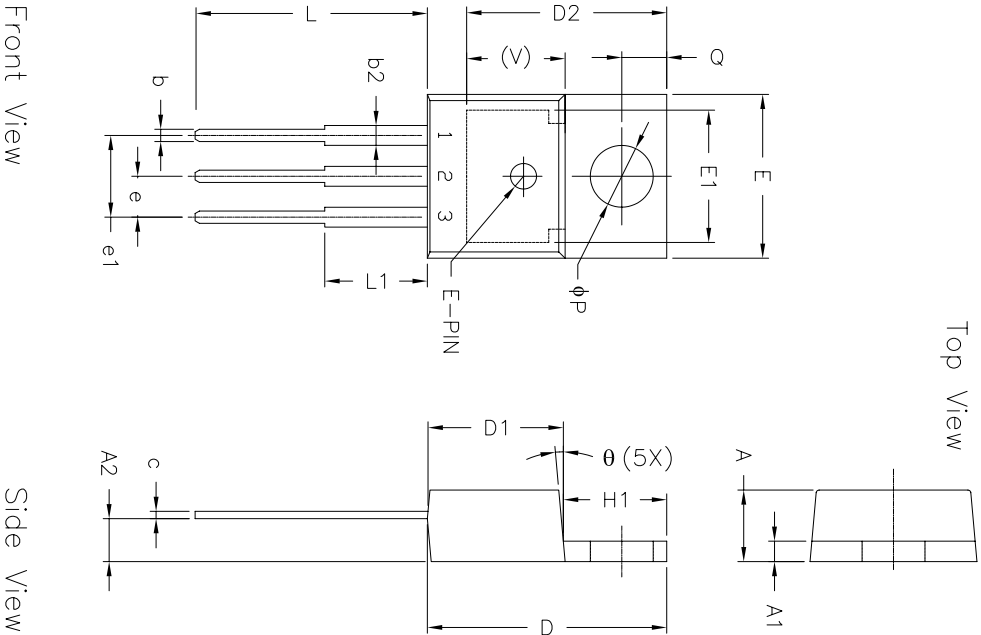

REVISION HISTORY			
REV.	DESCRIPTION	DATE	APP'D
A	DRAWING ORIGINATION	08/04/05	JL
B	DRAWING FORMAT MODIFICATION	05/25/06	JL

3 Pin T0-220 (Option 1) * JEDEC TO-220-AB					
SYMBOLS	DIMENSIONS IN INCH (Control Unit)		DIMENSIONS IN MM (Reference Unit)		
	MIN	MAX	MIN	MAX	
A	0.140	0.190	3.56	4.82	
A1	0.020	0.055	0.51	1.40	
A2	0.080	0.115	2.03	2.92	
b	0.015	0.040	0.38	1.02	
c	0.014	0.024	0.36	0.61	
D	0.560	0.650	14.22	16.51	
D1	0.330	0.355	8.38	9.02	
D2	0.480	0.507	12.19	12.88	
E	0.380	0.420	9.65	10.67	
E1	0.270	0.350	6.86	8.89	
e	0.100 BSC		2.54 BSC		
e1	0.200 BSC		5.08 BSC		
H1	0.230	0.270	5.84	6.86	
L	0.500	0.580	12.70	14.73	
L1	—	0.250	—	6.35	
P	0.139	0.156	3.53	3.96	
Q	0.103	0.113	2.62	2.87	
V	0.240 REF		6.10 REF		
theta	3°	7°	3°	7°	
N	3		3		

* Refer to product datasheet for P0D option being used

		SIPLEX CORPORATION	
Packaging Approval:		Drawing No:	
By: JL Date: 05/25/06		3 PIN TO-220 PACKAGE OUTLINE	
		Revision: B Sheet: 1 OF 2	

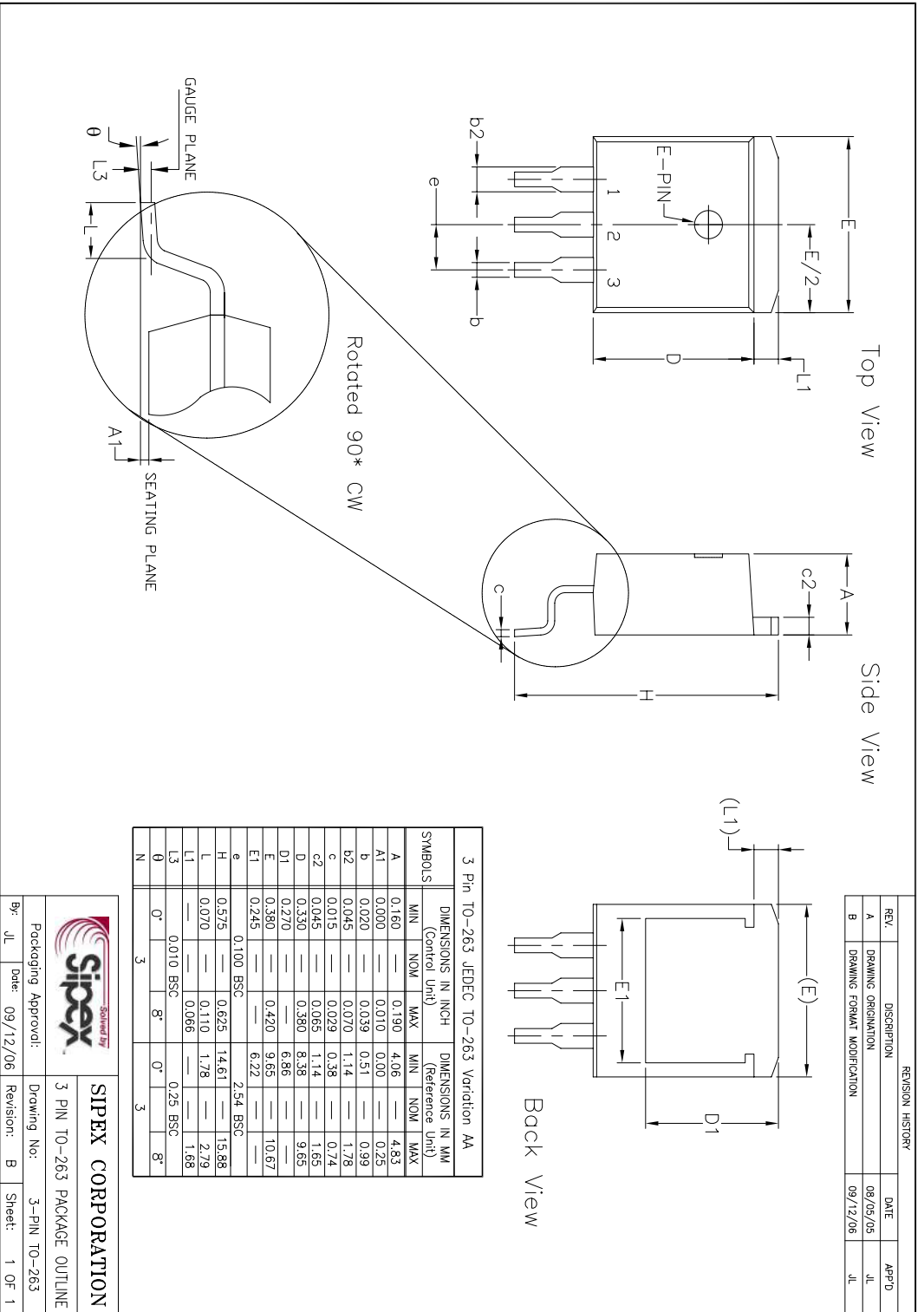

SIPEX CORPORATION

3 PIN T0-263 PACKAGE OUTLINE

Packaging Approver:  Drawing No: 3-PIN T0-263

By: JL Date: 09/12/06 Revision: B Sheet: 1 OF 1

PART NUMBER	Accuracy	OUTPUT VOLTAGE	PACKAGE
SPX1587AR	1%	Adj	3 lead TO-252
SPX1587AR/TR	1%	Adj	3 lead TO-252
SPX1587AR-1-5	1%	1.5V	3 lead TO-252
SPX1587AR-1-5/TR	1%	1.5V	3 lead TO-252
SPX1587AR-1-8	1%	1.8V	3 lead TO-252
SPX1587AR-1-8/TR	1%	1.8V	3 lead TO-252
SPX1587AR-2-5	1%	2.5V	3 lead TO-252
SPX1587AR-2-5/TR	1%	2.5V	3 lead TO-252
SPX1587AR-3-3	1%	3.3V	3 lead TO-252
SPX1587AR-3-3/TR	1%	3.3V	3 lead TO-252
SPX1587AR-5-0	1%	5.0V	3 lead TO-252
SPX1587AR-5-0/TR	1%	5.0V	3 lead TO-252
SPX1587AT	1%	Adj	3 lead TO-263
SPX1587AT/TR	1%	Adj	3 lead TO-263
SPX1587AT-1-5	1%	1.5V	3 lead TO-263
SPX1587AT-1-5/TR	1%	1.5V	3 lead TO-263
SPX1587AT-1-8	1%	1.8V	3 lead TO-263
SPX1587AT-1-8/TR	1%	1.8V	3 lead TO-263
SPX1587AT-2-5	1%	2.5V	3 lead TO-263
SPX1587AT-2-5/TR	1%	2.5V	3 lead TO-263
SPX1587AT-3-3	1%	3.3V	3 lead TO-263
SPX1587AT-3-3/TR	1%	3.3V	3 lead TO-263
SPX1587AT-5-0	1%	5.0V	3 lead TO-263
SPX1587AT-5-0/TR	1%	5.0V	3 lead TO-263
SPX1587AU	1%	Adj	3 lead TO-220
SPX1587AU-1-5	1%	1.5V	3 lead TO-220
SPX1587AU-1-8	1%	1.8V	3 lead TO-220
SPX1587AU-2-5	1%	2.5V	3 lead TO-220
SPX1587AU-3-3	1%	3.3V	3 lead TO-220
SPX1587AU-5-0	1%	5.0V	3 lead TO-220

Available in lead free packaging. To order add “-L” suffix to part number.
 Example: SPX1587AU-5-0/TR = standard; SPX1587AU-L-5-0/TR = lead free
 /TR = Tape and Reel

Pack quantity is 500 for TO-263 and 2,000 for TO-252.

For status updates,

<http://www.sipex.com/productDetails.aspx?varpart=SPX1587AR-L>



Sipex Corporation

**Headquarters and
Sales Office**

233 South Hillview Drive
 Milpitas, CA 95035
 TEL: (408) 934-7500
 FAX: (408) 935-7600

Sipex Corporation reserves the right to make changes to any products described herein. Sipex does not assume any liability arising out of the application or use of any product or circuit described herein; neither does it convey any license under its patent rights nor the rights of others.

ORDERING INFORMATION

PART NUMBER	Accuracy	OUTPUT VOLTAGE	PACKAGE
SPX1587R	2%	Adj	3 lead TO-252
SPX1587R/TR	2%	Adj	3 lead TO-252
SPX1587R-1-5	2%	1.5V	3 lead TO-252
SPX1587R-1-5/TR	2%	1.5V	3 lead TO-252
SPX1587R-1-8	2%	1.8V	3 lead TO-252
SPX1587R-1-8/TR	2%	1.8V	3 lead TO-252
SPX1587R-2-5	2%	2.5V	3 lead TO-252
SPX1587R-2-5/TR	2%	2.5V	3 lead TO-252
SPX1587R-2-8	2%	2.8V	3 lead TO-252
SPX1587R-2-8/TR	2%	2.8V	3 lead TO-252
SPX1587R-2-85	2%	2.85V	3 lead TO-252
SPX1587R-2-85/TR	2%	2.85V	3 lead TO-252
SPX1587R-3-3	2%	3.3V	3 lead TO-252
SPX1587R-3-3/TR	2%	3.3V	3 lead TO-252
SPX1587R-5-0	2%	5.0V	3 lead TO-252
SPX1587R-5-0/TR	2%	5.0V	3 lead TO-252
SPX1587T	2%	Adj	3 lead TO-263
SPX1587T/TR	2%	Adj	3 lead TO-263
SPX1587T-1-5	2%	1.5V	3 lead TO-263
SPX1587T-1-5/TR	2%	1.5V	3 lead TO-263
SPX1587T-1-8	2%	1.8V	3 lead TO-263
SPX1587T-1-8/TR	2%	1.8V	3 lead TO-263
SPX1587T-2-5	2%	2.5V	3 lead TO-263
SPX1587T-2-5/TR	2%	2.5V	3 lead TO-263
SPX1587T-3-3	2%	3.3V	3 lead TO-263
SPX1587T-3-3/TR	2%	3.3V	3 lead TO-263
SPX1587T-5-0	2%	5.0V	3 lead TO-263
SPX1587T-5-0/TR	2%	5.0V	3 lead TO-263
SPX1587U	2%	Adj	3 lead TO-220
SPX1587U-1-5	2%	1.5V	3 lead TO-220
SPX1587U-1-8	2%	1.8V	3 lead TO-220
SPX1587U-2-5	2%	2.5V	3 lead TO-220
SPX1587U-3-3	2%	3.3V	3 lead TO-220
SPX1587U-5-0	2%	5.0V	3 lead TO-220

Available in lead free packaging. To order add “-L” suffix to part number.

Example: SPX1587T-5.0/TR = standard; SPX1587T-L-5.0/TR = lead free

/TR = Tape and Reel

Pack quantity is 500 for TO-263 and 2,000 for TO-252.

For status updates, <http://www.sipex.com/productDetails.aspx?varpart=SPX1587AR-L>



Sipex Corporation

**Headquarters and
Sales Office**

233 South Hillview Drive
Milpitas, CA 95035
TEL: (408) 934-7500
FAX: (408) 935-7600

Sipex Corporation reserves the right to make changes to any products described herein. Sipex does not assume any liability arising out of the application or use of any product or circuit described herein; neither does it convey any license under its patent rights nor the rights of others.