

THIS DRAWING IS UNPUBLISHED. RELEASED FOR PUBLICATION  
 © COPYRIGHT BY TYCO ELECTRONICS CORPORATION. ALL RIGHTS RESERVED.

LOC		DIST		REVISIONS			
P	LTR	DESCRIPTION	DATE	OWN	APVD		
	C1	REVISED PER ECR-12-022060	17FEB13	CX	LL		

- 1 CONTINUOUS STRIP ON REELS WITH TERMINALS LOCATED ON 8.38±0.08 [.330±.003] CENTERS.
- 2 SLOTS ACCEPT EITHER A SINGLE OR DOUBLE MAGNET WIRE OF THE SAME SIZE AND TYPE. COPPER RANGE: 0.30-0.51mm [#28.5-#24] AWG.
- 3 POKE-IN ACCEPTS A 0.81-1.02mm<sup>2</sup> [#20-#18] AWG SOLID OR FUSED STRANDED LEAD WIRE.
- 4 PRELIMINARY - NOT FOR PRODUCTION.
- 5 PREPRODUCTION - FASR REQUIRED

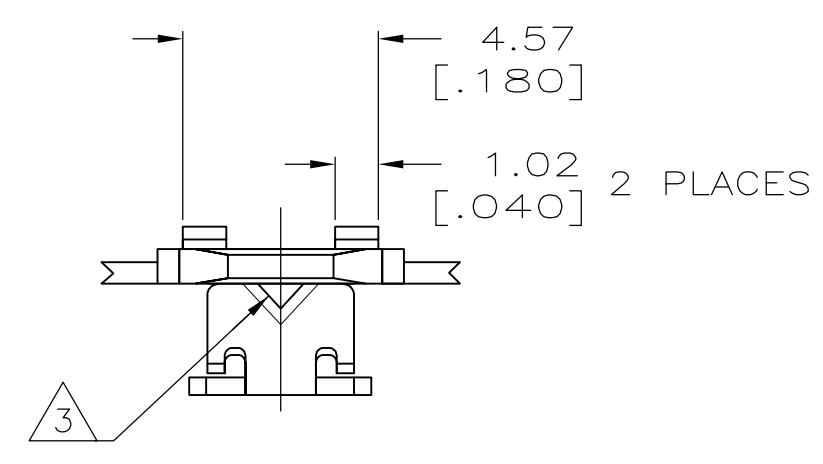

IDENTIFICATION NUMBER 9 FOR MAGNET WIRE RANGE

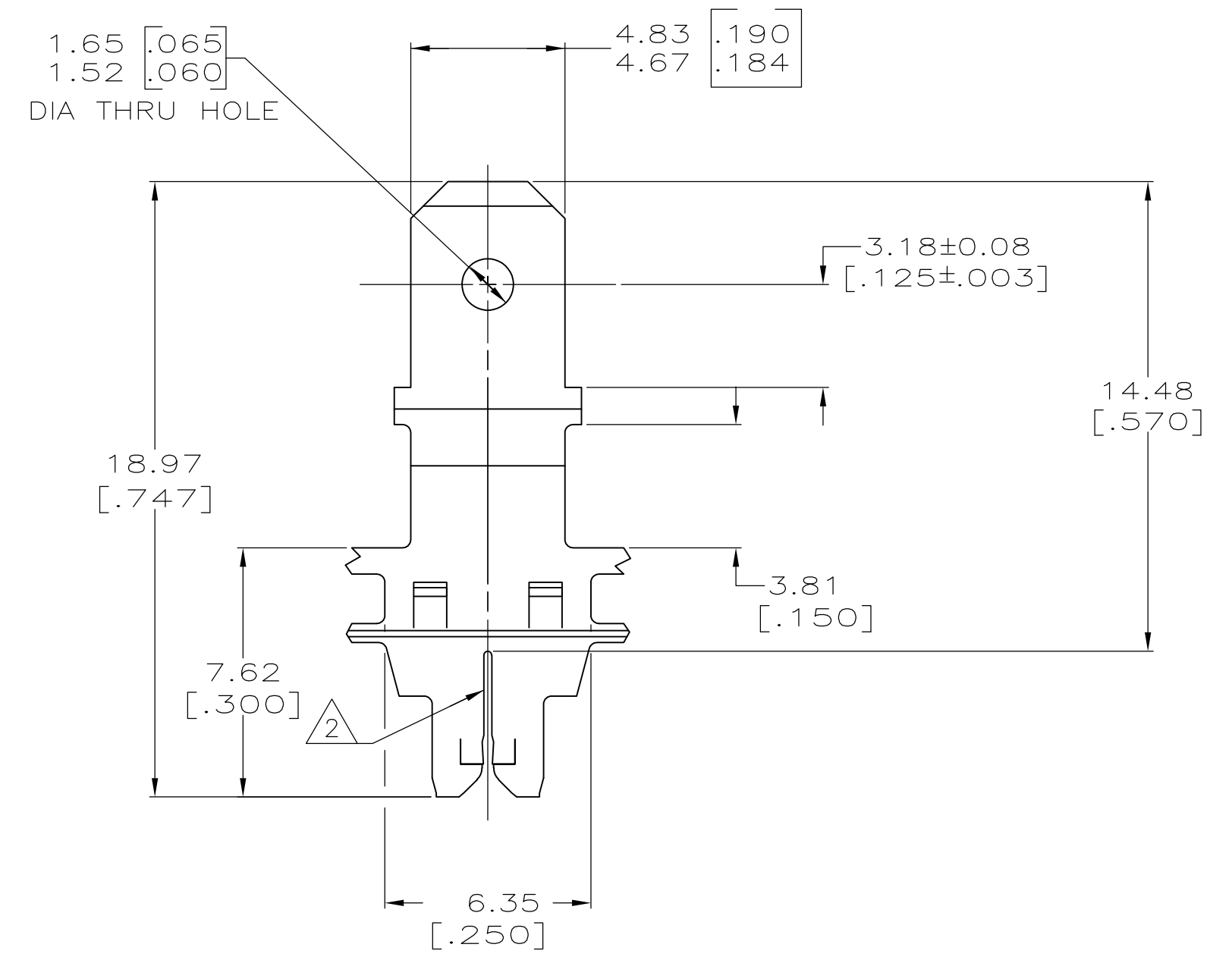
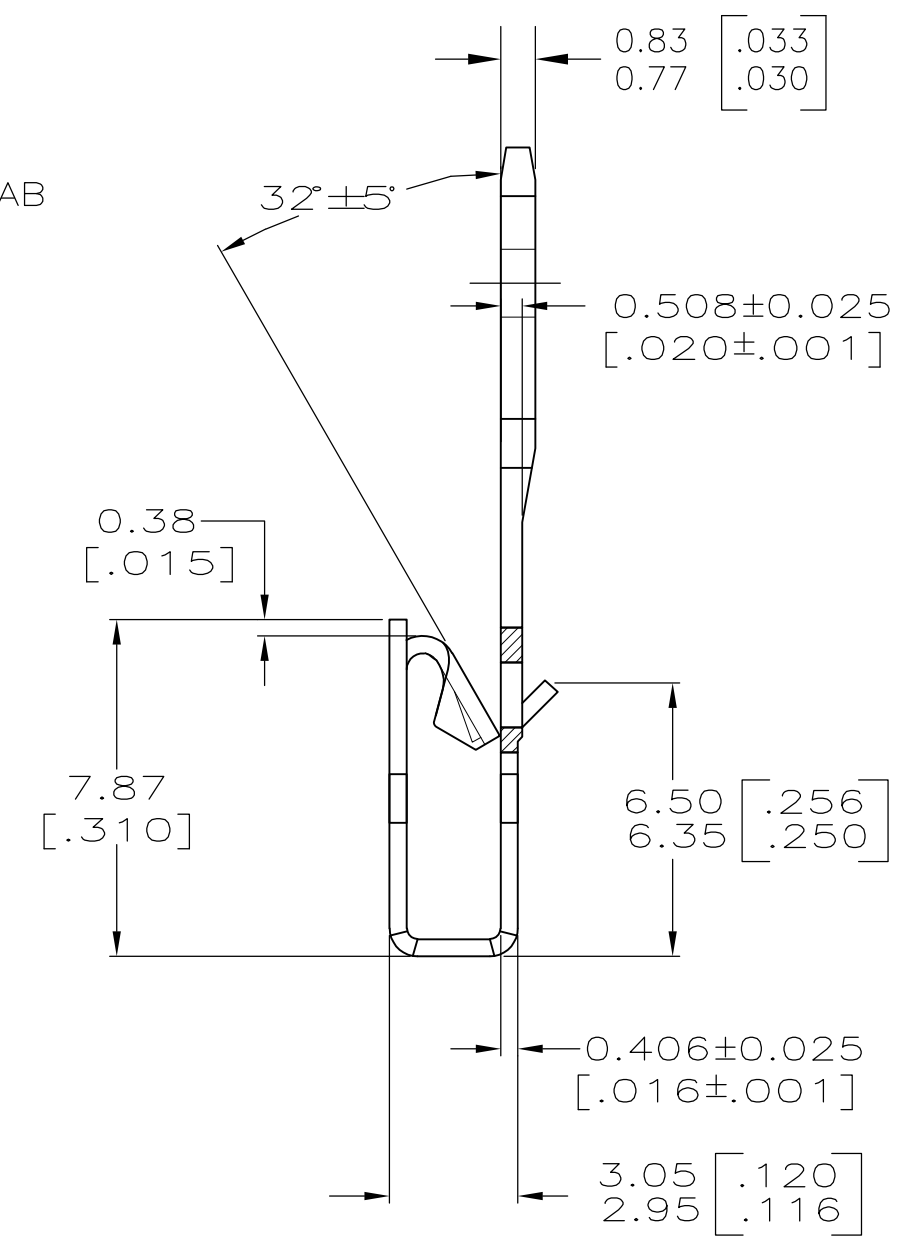
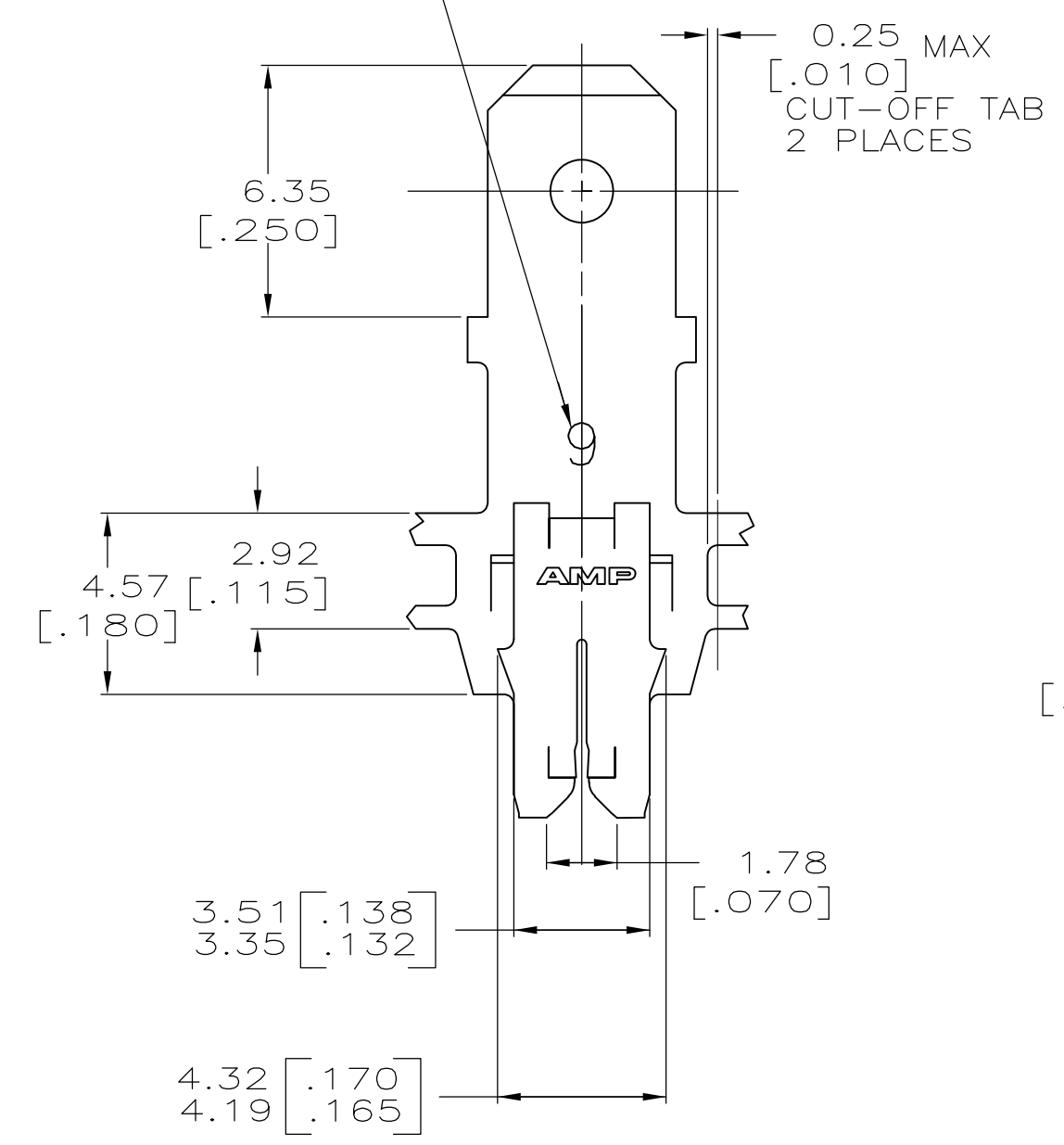

	4M PRE-MILLED BRASS	4	1217857-2
OBSOLETE	<del>082 PRE-MILLED BRASS</del>	5	<del>1217857-1</del>
MATERIAL		PART NUMBER	

THIS DRAWING IS A CONTROLLED DOCUMENT.		DWN 23JUL2002 MICHAEL S. FEHER	Tyco Electronics Corporation Harrisburg, PA 17105-3608	
DIMENSIONS: mm [INCHES]		CHK 23JUL2002 KURT A. RANDOLPH	NAME KURT A. RANDOLPH	
TOLERANCES UNLESS OTHERWISE SPECIFIED:		APVD 23JUL2002 KURT A. RANDOLPH	PRODUCT SPEC 108-2012	
0 PLC ± -		APPLICATION SPEC 114-2094		
1 PLC ± -		SIZE CAGE CODE DRAWING NO RESTRICTED TO		
2 PLC ± 0.25[.010]		A2 00779 G-1217857		
3 PLC ± -		WEIGHT -		
4 PLC ± -		CUSTOMER DRAWING		
ANGLES ± -		SCALE 6:1 SHEET 1 OF 1 REV C1		
FINISH 0.002032[.000080] MIN TIN PLATE				