

Future Technology Devices International Limited Datasheet *CleO50* Module

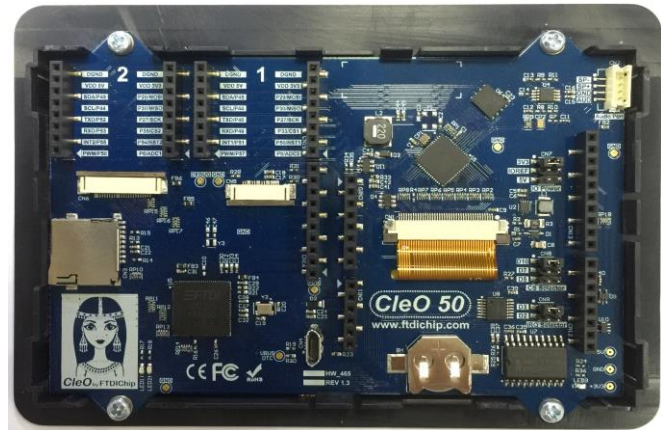

1 Introduction

The CleO50 is a smart TFT display shield for Arduino and MikroBUS. It includes a 5.0 inch 800x480 pixel TFT LCD panel with resistive touch, PWM audio output with in-built speaker amplifier for better audio quality.

These smart TFT display shields can be easily programmed by almost anyone to give professional looking HMI / GUI's with no prior knowledge of complex graphics programming or mathematics.

1.1 Features

The CleO50 utilises the FTDI FT900 low power MCU to bridge between the Arduino and fast interface accessories such as MikroBUS, camera and SD Card input. For a full list of the FT900's features refer to the [FT90X datasheet](#). In addition, the CleO50 has the following features:

- Support landscape and portrait modes
- In built FTDI FT812 embedded video engine (EVE) graphic controller
- Anti-aliased graphics throughout for much finer image quality with no "jaggies"
- Ready to use LCD module with resistive touch in panel mountable bezel
- USB DFU port for firmware updates
- In built 8M Byte Eflash memory
- PWM audio supported and in built speaker amplifier
- Support MikroBUS interface
- Support Micro SD card
- Support camera interface
- Support I2S interface
- Support CAN bus
- Support RTC function
- Designed as Arduino and *NerO* shield
- Compatible with FTDI CleO-RIO, CleO-Camera and CleO-Speaker
- CE and FCC certified

Note: MikroBus interface is created by MikroElektronika is an open standard anyone can implement in their design. Please visit [MikroE](#) for more detail

Neither the whole nor any part of the information contained in, or the product described in this manual, may be adapted or reproduced in any material or electronic form without the prior written consent of the copyright holder. This product and its documentation are supplied on an as-is basis and no warranty as to their suitability for any particular purpose is either made or implied. Future Technology Devices International Ltd will not accept any claim for damages howsoever arising as a result of use or failure of this product. Your statutory rights are not affected. This product or any variant of it is not intended for use in any medical appliance, device or system in which the failure of the product might reasonably be expected to result in personal injury. This document provides preliminary information that may be subject to change without notice. No freedom to use patents or other intellectual property rights is implied by the publication of this document. Future Technology Devices International Ltd, Unit 1, 2 Seaward Place, Centurion Business Park, Glasgow G41 1HH United Kingdom. Scotland Registered Company Number: SC136640

2 Ordering Information

Part No.	Description
CleO50A	CleO50 module, with FPC/FFC 40 LCD connector, 5.0 inch TFT LCD display panel preinstalled with resistive touch. Black bezel.
CleO-RIO1	Arduino Shield for users to stack Arduino board on bottom of <i>CleO50</i> .
CleO-CAM1	A camera plug-in module for <i>CleO50</i> .
CleO-SPK1	A speaker enclosure with connecting wires to <i>CleO50</i> .

3 Program Support

Demo applications are provided for CleO50 modules by FTDI. Visit FTDI's website <http://www.ftdichip.com/Products/Modules/CleO.htm> for more information.

Table of Contents

1	Introduction	1
1.1	Features.....	1
2	Ordering Information	2
3	Program Support.....	2
4	Module Hardware Feature	5
4.1	Power Supply	6
4.2	Micro-controller	6
4.3	Micro SD Interface	6
4.4	LCD Interface.....	7
4.5	Camera Interface	9
4.6	Audio Output.....	11
4.7	SPI Slave Interface	12
4.8	MikroBUS Interface.....	13
4.9	I ² S Interface and CAN Bus	15
4.10	Power and Program Interface.....	15
4.11	MCU Interrupt Interface.....	16
4.12	External Real Time Clock (RTC)	16
5	Devices Characteristics and Ratings.....	17
5.1	Electrical Specification	17
5.2	Display Specification	17
5.3	Optical Specification	18
6	Board Schematics.....	20
7	Block Diagram	23
8	Mechanical Dimensions	24
8.1	CleO50 Module Dimensions	24
8.2	Bezel Drawing.....	25
9	Contact Information.....	26
Appendix A – References		27
Document References		27

Acronyms and Abbreviations	27
Appendix B - List of Figures and Tables	28
List of Tables	28
List of Figures	28
Appendix C – Revision History	29

4 Module Hardware Feature

The dimensions of the CleO50 module are 142 mm x 99 mm X17.8mm. See Figure 1 for all the hardware features.

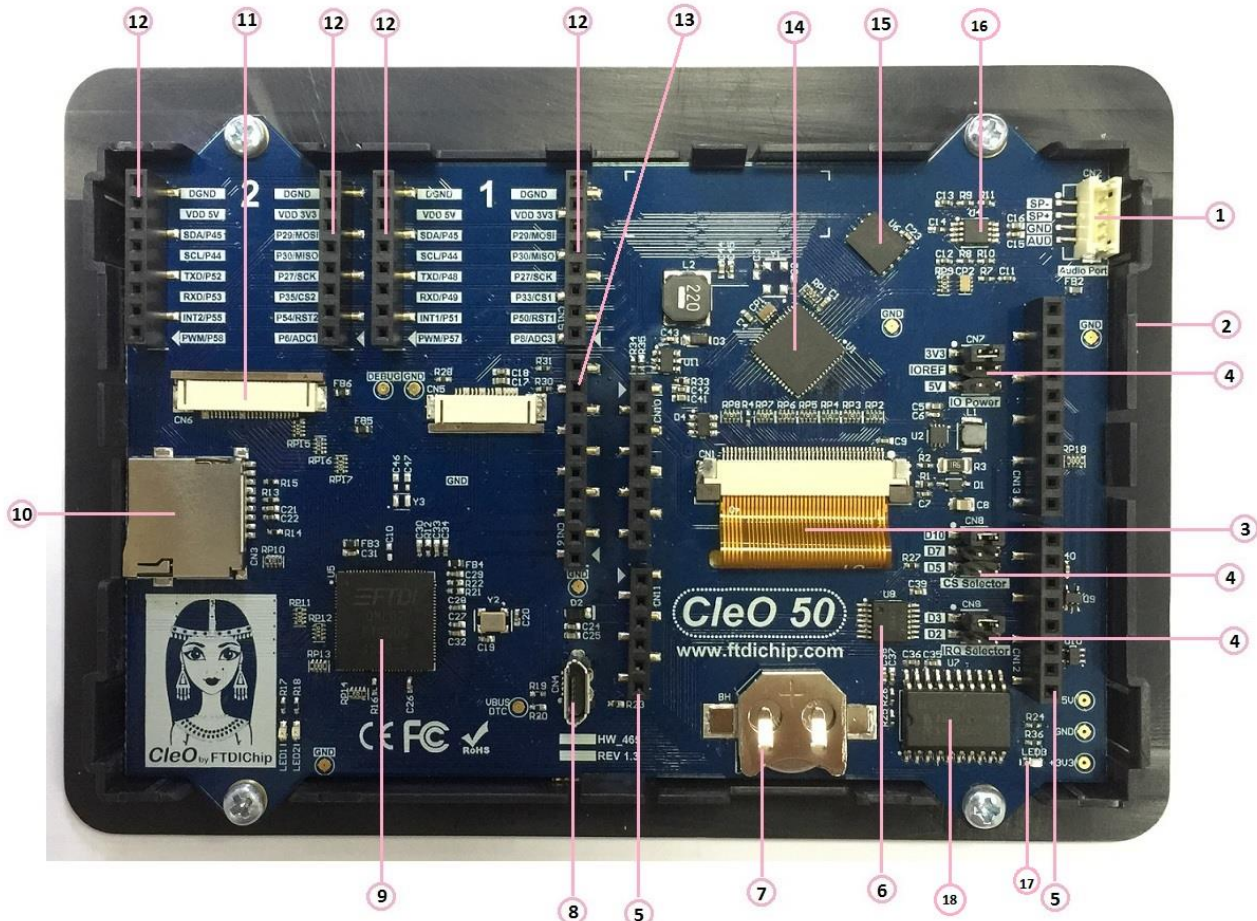

Figure 1 - CleO50 Bottom View

Key Features:

- | | |
|---|---------------------------------|
| 1 Speaker out / Line in | 2 Plastic Bezel |
| 3 5.0 in HVGA TFT I/F + Resistive Touch | 4 Arduino Configuration Jumpers |
| 5 Arduino I/F | 6 Level Shifter |
| 7 Battery Holder | 8 USB DFU Connector |
| 9 FT900 MCU | 10 MicroSD Card Socket |
| 11 Camera Interface | 12 MikroBus Interface |
| 13 I2S & Can Bus Interface | 14 FT812 GPU |
| 15 8M Byte E-Flash | 16 Audio Amplifier |
| 17 Power indicator LED | 18 RTC Circuitry |

4.1 Power Supply

The CleO50 module receives power externally. Users can combine the module with the FCC/CE certified *NerO* or Arduino UNO and draw power from those board supplies. For details of the *NerO* module, refer to [FTDI-NerO](#) for more Information.

Alternatively, the on board USB connector, **CN4** which is primarily for debug purpose and DFU firmware upgrade may also supply power.

Once the 5V supply is applied, a Red LED power indicator will be turned on. A step down regulator **U11** will step down the 5V to 3.3V. The 3.3V supply will serve all peripherals of the FT900 microcontroller.

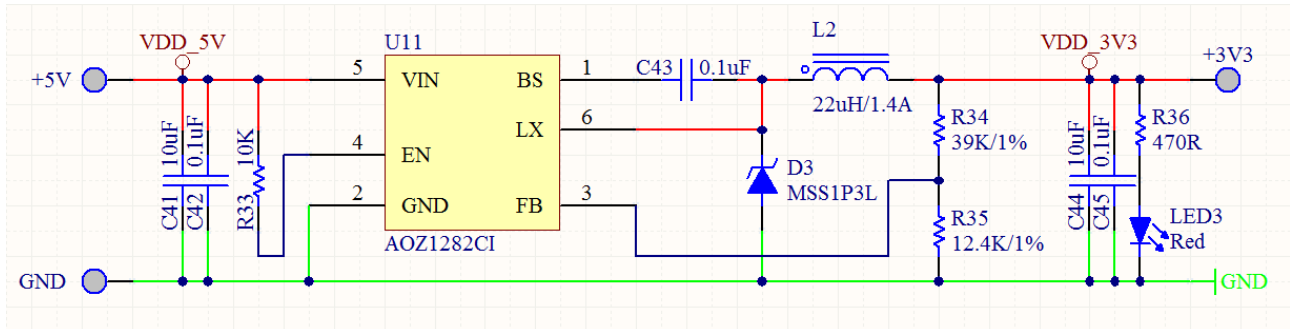

Figure 2 - Power Supply

4.2 Micro-controller

The FT900Q 100-pin QFN microcontroller which is provided on the board belongs to 32-bit FT90X Super Bridging Microcontroller family from FTDI Chip. For details of the FT900Q Microcontroller, refer to [FT90X datasheet](#).

4.3 Micro SD Interface

A Micro SD card slot is provided on CleO50 supporting two standard capacity card types:

- Secure Digital (SD) standard – Up to 2GB SD memory card
- Secure Digital High Capacity (SDHC) standard – Over 4GB-32GB SDHC memory card

The SD host controller is compatible with the standard specification V3.0. It supports up to 25MHz SD clock speed. In the CleO50 design, the physical interface supports 4-bit SD bus mode and card detection.

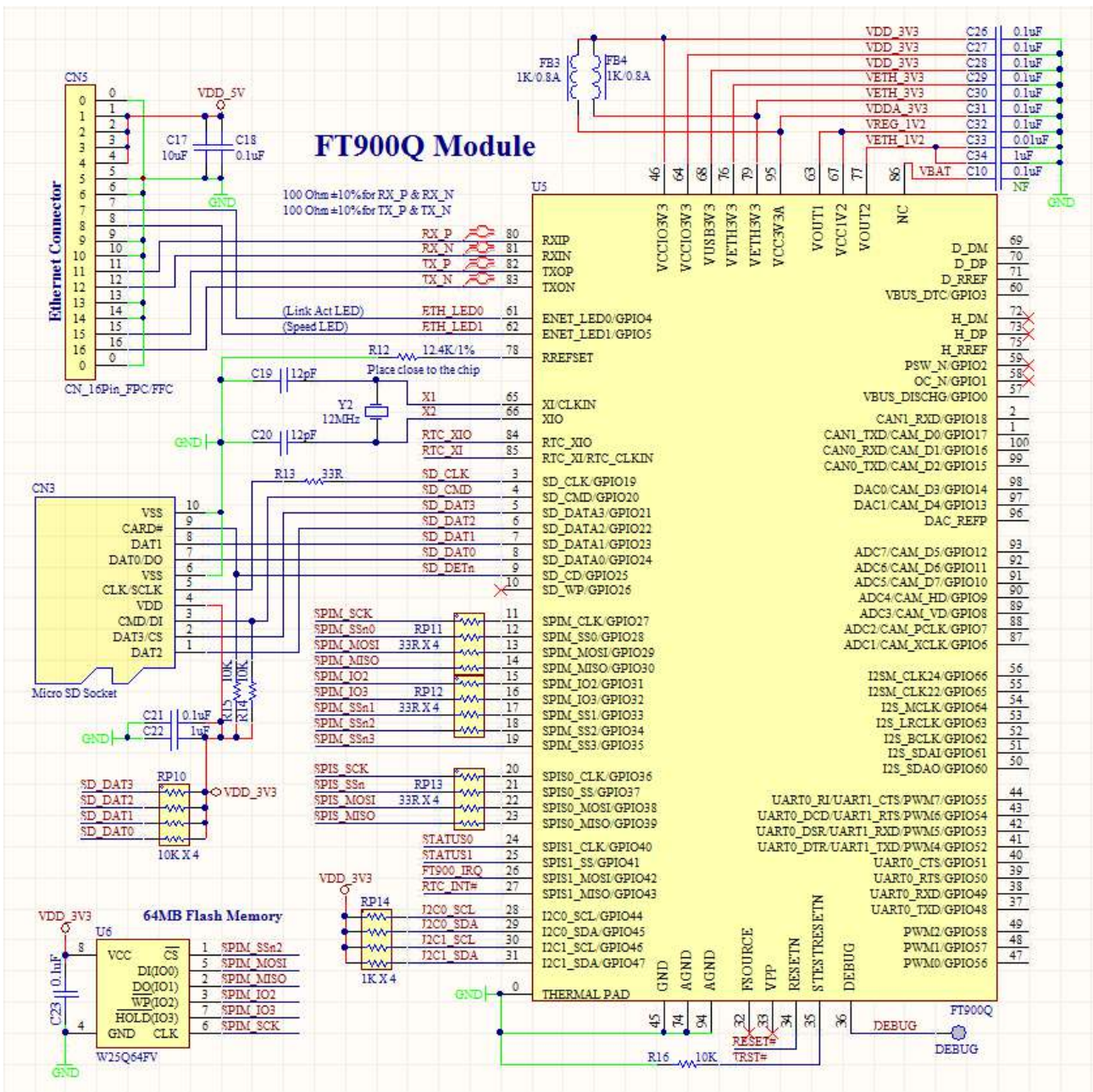

Figure 3 – MicroSD Interface

4.4 LCD Interface

In the CleO50 design, a 5.0 inch TFT LCD with resistive touch is supported. The FT812Q 56pin VQFN graphics controller IC with integrated touch and audio belongs to FTDI’s EVE series. For further details of the FT812Q EVE graphics controller, refer to the [FT81X datasheet](#).

The 5.0 inch LCD is connected through the 40 pin FPC/FPC connector **CN1**. See Table 1 for the LCD connector pinout.

Pin No.	Name	Description
1	LEDK	Backlight LED Cathode
2	LEDA	Backlight LED Anode
3	GND	Ground
4	VDD_3V3	LCD VCC Supply
5	R0	Bit 0 of Red RGB Signal
6	R1	Bit 1 of Red RGB Signal
7	R2	Bit 2 of Red RGB Signal
8	R3	Bit 3 of Red RGB Signal
9	R4	Bit 4 of Red RGB Signal
10	R5	Bit 5 of Red RGB Signal
11	R6	Bit 6 of Red RGB Signal
12	R7	Bit 7 of Red RGB Signal
13	G0	Bit 0 of Green RGB Signal
14	G1	Bit 1 of Green RGB Signal
15	G2	Bit 2 of Green RGB Signal
16	G3	Bit 3 of Green RGB Signal
17	G4	Bit 4 of Green RGB Signal
18	G5	Bit 5 of Green RGB Signal
19	G6	Bit 6 of Green RGB Signal
20	G7	Bit 7 of Green RGB Signal
21	B0	Bit 0 of Blue RGB Signal
22	B1	Bit 1 of Blue RGB Signal
23	B2	Bit 2 of Blue RGB Signal
24	B3	Bit 3 of Blue RGB Signal
25	B4	Bit 4 of Blue RGB Signal
26	B5	Bit 5 of Blue RGB Signal
27	B6	Bit 6 of Blue RGB Signal
28	B7	Bit 7 of Blue RGB Signal
29	GND	Ground
30	PCLK	Pixel Clock
31	DISP	LCD Display Enable
32	HSYNC	LCD Horizontal Sync
33	VSYNC	LCD Vertical Sync
34	DE	LCD Data Enable
35	NC	No Connection
36	GND	Ground

37	XP	X Right Electrode of 4-Wire Resistive Touch-Screen Panel
38	YM	Y Bottom Electrode of 4-Wire Resistive Touch-Screen Panel
39	XM	X Left Electrode of 4-Wire Resistive Touch-Screen Panel
40	YP	Y Top Electrode of 4-Wire Resistive Touch-Screen Panel

Table 1 – LCD Connector Pin Out

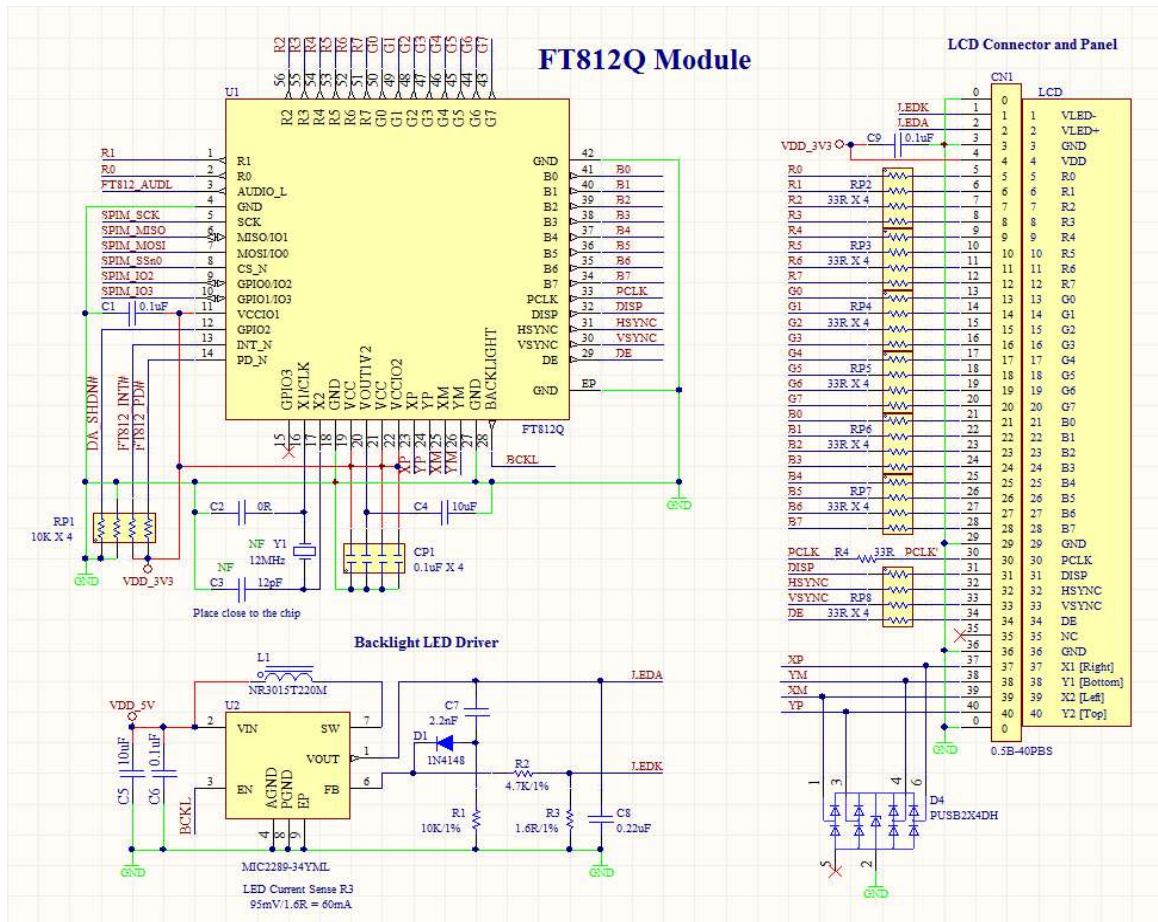

Figure 4 – LCD Interface

4.5 Camera Interface

The CleO50 has a camera module interface, via a 24-pin 0.5mm pitch FFC/FPC, bottom contact connector, **CN6**. In this design, support is provided for an OmniVision OV5640 camera module. A readymade camera module (CleO-CAM1) can be purchased from FTDI .Support for further camera modules may be added in the future. Please visit the [FTDI](http://www.ftdi.com) website for more information.

See table 2 for the Camera interface pinout.

Pin No.	Name	Description
1	GND	Ground
2	GND	Ground
3	I2C1_SDA	I2C Serial Bus, Data Line
4	CAM_5V	5V Power Supply
5	I2C1_SCL	I2C Serial Bus, Clock Line
6	RESET#	Hardware Reset, Active Low
7	CAM_VD	Camera Vertical Sync Input
8	CAM_PWDN	Camera Module Power Down Signal, Active High
9	CAM_HD	Camera Horizontal Reference Input
10	CAM_3V3	3.3V Power Supply
11	CAM_3V3	3.3V Power Supply
12	CAM_D7	Camera Data Line, Bit 7
13	CAM_XCLK	Camera External Clock Output
14	CAM_D6	Camera Data Line, Bit 6
15	GND	Ground
16	CAM_D5	Camera Data Line, Bit 5
17	CAM_PCLK	Camera Pixel Clock Input
18	CAM_D4	Camera Data Line, Bit 4
19	CAM_D0	Camera Data Line, Bit 0
20	CAM_D3	Camera Data Line, Bit 3
21	CAM_D1	Camera Data Line, Bit 1
22	CAM_D2	Camera Data Line, Bit 2
23	CAM_5V	5V Power Supply
24	PWM0	Pulse Width Modulation 0

Table 2 – Camera Connector Pin Out

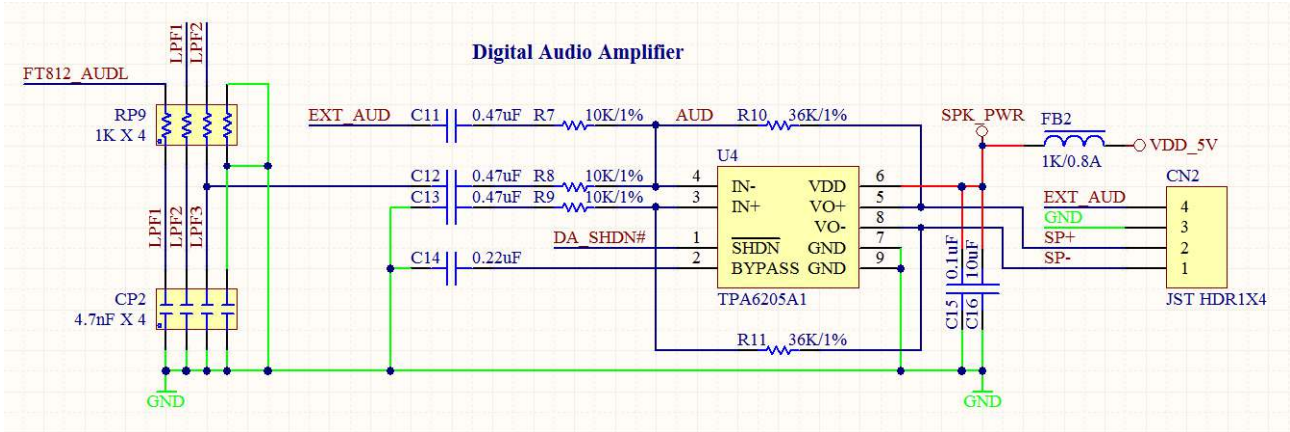

Figure 6 – Speaker Amplifier Circuitry

4.7 SPI Slave Interface

The CleO50 has a SPI slave interface that supports single and dual (2 data lines) SPI data transfer modes. This interface supports both 5V, 3.3V as well as user defined output levels. The user defined interface levels must be between 3V (min) to 5.5V (max). The power selection jumper is through **CN7**.

Pin No.	Description
1-2	3.3V SPI interface
3-4	SPI interface voltage level follows user setting (IOREF)
5-6	5V SPI interface

Table 4 – CN7 Jumper Selection

There are chip select (CS) jumper selections on **CN8**. The user has 3 options to choose for their connection.

Pin No.	Description
1-2	SPI chip select from D10 (option 1)
3-4	SPI chip select from D7 (option 2)
5-6	SPI chip select from D5 (option 3)

Table 5 – CN8 Jumper Selection

For the SPI Slave interface, there are two connectors for the user to interface with the master side.

- The **CN13** – 1X10 position 2.54mm pitch female header
- The **CN12** – 1X8 position 2.54mm pitch female header

Pin No.	Name	Description
1	-	No Connection
2	-	No Connection
3	D10	SPI Chip Select Option 1
4	MOSI	SPI Data from Master Side

5	MISO	SPI Data to Master Side
6	SCK	SPI Clock
7	GND	Ground
8	-	No Connection
9	-	No Connection
10	-	No Connection

Table 6 – CN13 Pin Out

Pin No.	Name	Description
1	-	No Connection
2	-	No Connection
3	D2	FT900 Interrupt Request Out Option 1
4	D3	FT900 Interrupt Request Out Option 2
5	-	No Connection
6	D5	SPI Chip Select Option 3
7	-	No Connection
8	D7	SPI Chip Select Option 2

Table 7 – CN12 Pin Out

4.8 MikroBUS Interface

The CleO50 has dual MikroBUS interfaces through **CN14** & **CN15** for MikroBUS 1 and **CN17** & **CN18** for MikroBUS 2.

See Table 8 for MikroBUS 1 interface pinout.

See Table 9 for MikroBUS 2 interface pinout.

Pin No. of CN14	Name	Description
1	PWM1	Pulse Width Modulation 1
2	UART0_CTS	Clear to Send Input for UART0
3	UART0_RXD	Receiver Input for UART0
4	UART0_TXD	Transmitter Output for UART0
5	I2C0_SCL	I2C0 Serial Clock Input/Output
6	I2C0_SDA	I2C0 Data Line Input/Output
7	VDD_5V	5V Power Supply
8	GND	Ground
Pin No. of CN15	Name	Description
1	GPIO8	10-Bit A/D Converter 3, Input

2	UART0_RTS	Request to Send Output for UART0
3	SPIM_SS _n 1	Slave Select 1 Output for SPI Master
4	SPIM_SCK	Serial Clock Output for SPI Master
5	SPIM_MISO	Master In Slave Out for SPI Master
6	SPIM_MOSI	Master Out Slave In for SPI Master
7	VDD_3V3	3.3V Power Supply
8	GND	Ground

Table 8 - MikroBUS 1 Interface Pin Out

Pin No. of CN17	Name	Description
1	PWM2	Pulse Width Modulation 2
2	UART1_CTS	Clear to Send Input for UART1
3	UART1_RXD	Receiver Input for UART1
4	UART1_TXD	Transmitter Output for UART1
5	I2C0_SCL	I2C0 Serial Clock Input/Output
6	I2C0_SDA	I2C0 Data Line Input/Output
7	VDD_5V	5V Power Supply
8	GND	Ground
Pin No. of CN18	Name	Description
1	GPIO6	10-Bit A/D Converter 1, Input
2	UART1_RTS	Request to Send Output for UART1
3	SPIM_SS _n 3	Slave Select 3 Output for SPI Master
4	SPIM_SCK	Serial Clock Output for SPI Master
5	SPIM_MISO	Master In Slave Out for SPI Master
6	SPIM_MOSI	Master Out Slave In for SPI Master
7	VDD_3V3	3.3V Power Supply
8	GND	Ground

Table 9 - MikroBUS 2 Interface Pin Out

4.9 I²S Interface and CAN Bus

The CleO50 has a combined interface of full I2S signals and CAN bus through **CN16**, 1X10 position 2.54mm pitch female header.

See Table 10 for connector CN16 pinout.

Pin No.	Name	Description
1	I2SM_CLK24	I2S Master External 24.576MHz Clock Input
2	I2SM_CLK22	I2S Master External 22.5792MHz Clock Input
3	I2S_MCLK	I2S Master Transmitter Clock Output
4	I2S_LRCLK	Left / Right Clock Line Output for I2S Master Transmitter or Input for I2S Slave Receiver
5	I2S_BCLK	Bit Clock Line Output for I2S Master Transmitter or Input for I2S Slave Receiver
6	I2S_SDAI	Serial Data Line Input for I2S Master or Slave
7	I2S_SDAO	Serial Data Line Output for I2S Master or Slave
8	GND	Ground
9	CAN0_RXD	CAN0 Receiver Input
10	CAN0_TXD	CAN0 Transmitter Output

Table 10 – CN16 Pin Out

4.10 Power and Program Interface

The power interface **CN10**, 1X8 position 2.54mm pitch female header, may be driven by NerO or an Arduino UNO.

Users can use the USB connector **CN4** for FT900 firmware upgrades. For the details of the tool operation, refer to [AN_325_FT900_Tool_Chain_Installation_Guide_document](#).

Pin No.	Name	Description
1	-	No Connection
2	IOREF	IO Reference Voltage
3	RESET	FT900 Reset Pin
4	-	No Connection
5	VDD_5V	5V Power Supply
6	GND	Ground
7	GND	Ground
8	-	No Connection

Table 11 – CN10 Pin Out

4.11 MCU Interrupt Interface

There is a jumper selection for the FT900 interrupt request through **CN9**. Users have 2 options to choose from.

Pin No.	Description
1-2	Connect to Arduino/NerO MCU int0(D3)
3-4	Connect to Arduino/NerO MCU int1(D2)

Table 12 – CN9 Jumper Selection

4.12 External Real Time Clock (RTC)

The CleO50 has an external RTC through I2C1 channel and supplied by backup battery (CR-1220) during off-mode.

5 Devices Characteristics and Ratings

5.1 Electrical Specification

Parameter	Value	Unit	Conditions
Storage Temperature	-30°C to 80°C	Degrees C	
Ambient Operating Temperature (Power Applied)	-20°C to 70°C	Degrees C	

Table 13 - Temperature Parameter

DC Characteristics (Ambient Temperature = -20°C to +70°C)

Parameter	Description	Minimum	Typical	Maximum	Units	Conditions
V _{bus}	USB Power Supply	4.75		5.25	V	
V _{DC}	DC Power Supply	4.75		5.25	V	External Source
I _{usb}	USB Power Supply Current			500	mA	
I _{DC}	DC Supply Current			1	A	DC=5V, external source
I _{idle}	DC Current in Idle Mode		426		mA	With LCD and Backlight On
V _{io}	3.3 Vio Voltage Reference	3.0	3.3	3.6	V	
V _{ih}	Input High Voltage	2			V	
V _{il}	Input Low Voltage			0.8	V	
V _{oh}	Output High Voltage	2.4			V	
V _{ol}	Output Low Voltage			0.4	V	

Table 14 – Operating Voltage and Current

5.2 Display Specification

Item	Spec	Units	Notes
Display Area(AA)	108.00(W) * 64.8(H)	mm	5 Inch Diagonal
Driver Element	TFT Active Matrix	mA	
Display Colors	16.7M	-	
Number of Pixels	800(RGB)*480	dots	
Viewing Angle	12:00	o'clock	Landscape View
Display Mode	Transmissive/ Normally White	-	

Item	Spec	Units	Notes
LCD Luminance	400	cd/m ²	
Touch Screen	Resistive	-	

Table 15 – Display Specification

5.3 Optical Specification

Brightness (With TP)	Bp	$\theta=0^\circ$ $\Phi=0^\circ$	400	-	Cd/m ²	1	
Uniformity	ΔBp		75	-	%	1,2	
Viewing Angle	3:00	$Cr \geq 10$	-	60	-	Deg	3
	6:00		-	45	-		
	9:00		-	60	-		
	12:00		-	60	-		
Contrast Ratio	Cr	$\theta=0^\circ$ $\Phi=0^\circ$	300	500	-	4	
Response Time	T _r	$\theta=0^\circ$ $\Phi=0^\circ$	-	10	-	ms	5
	T _f		-	10	-	ms	
Color of CIE Coordinate	W	$\theta=0^\circ$ $\Phi=0^\circ$	x	0.28	-	1,6	
			y	0.33	-		
	R		x	0.51	-		
			y	0.34	-		
	G		x	0.31	-		
			y	0.56	-		
	B		x	0.15	-		
			y	0.14	-		
NTSC Ratio	S	50	60	-	%		

Table 16 – 5.0 Inch TFT Optical Specification

Note: The parameter is slightly changed by temperature, driving voltage and material

Note 1: The data are measured after LEDs are turned on for 5 minutes. LCM displays full white.
The brightness is the average value of 9 measured spots. Measurement equipment PR-705 (Φ8mm)

Measuring condition:

- Measuring surroundings: Dark room.
- Measuring temperature: $T_a=25^{\circ}\text{C}$.
- Adjust operating voltage to get optimum contrast at the center of the display.

Measured value at the center point of LCD panel after more than 5 minutes while backlight turning on.

Note 3: The definition of viewing angle:

Refer to the graph below marked by θ and ϕ

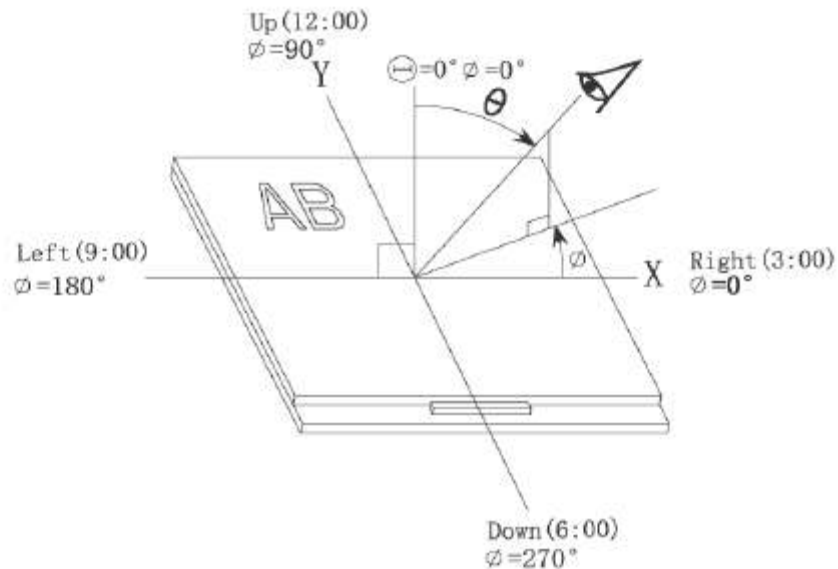

Figure 3 – Viewing Angle of the LCD

6 Board Schematics

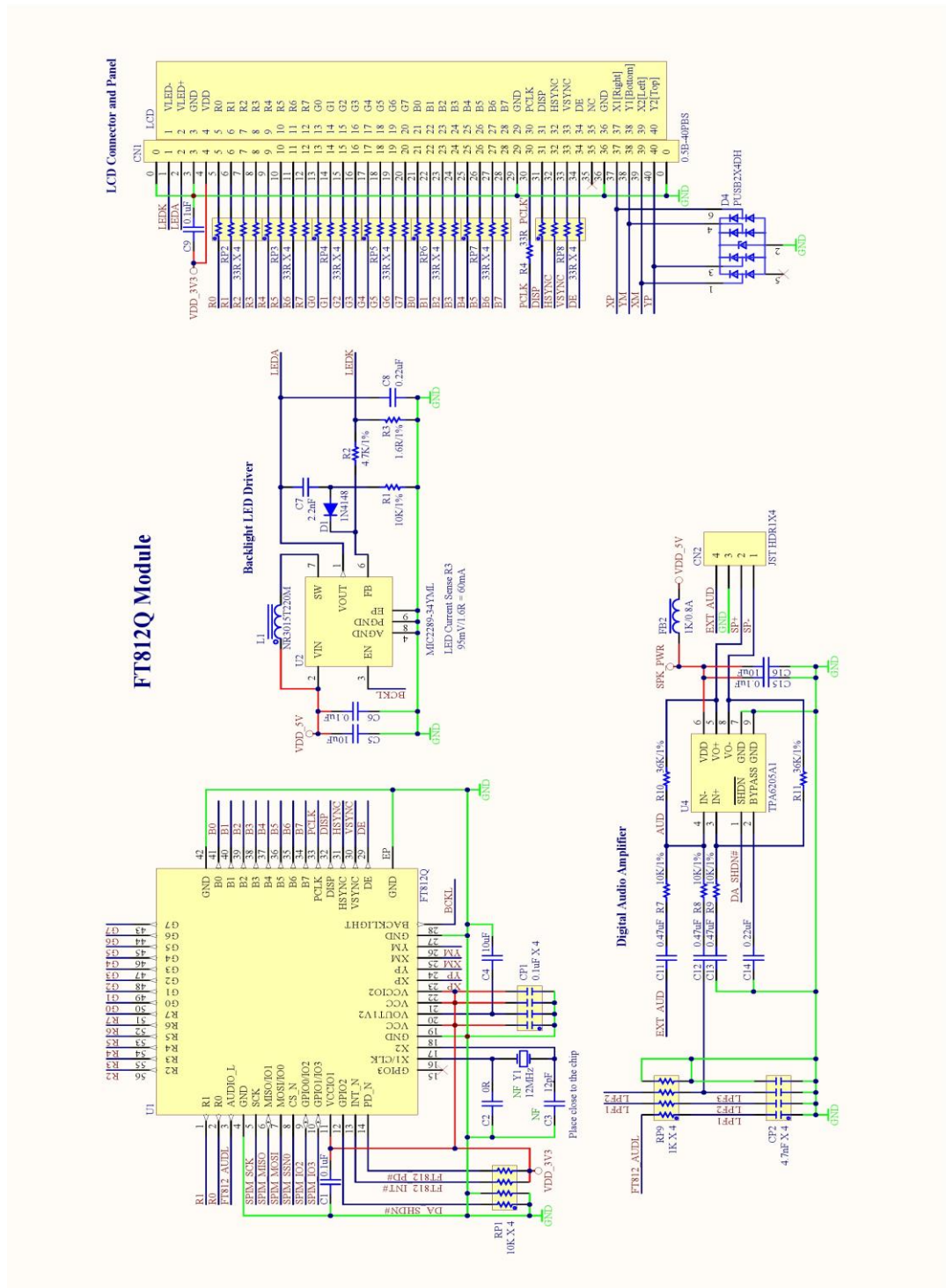

Figure 4 - Sheet 1 - FT812Q Connection

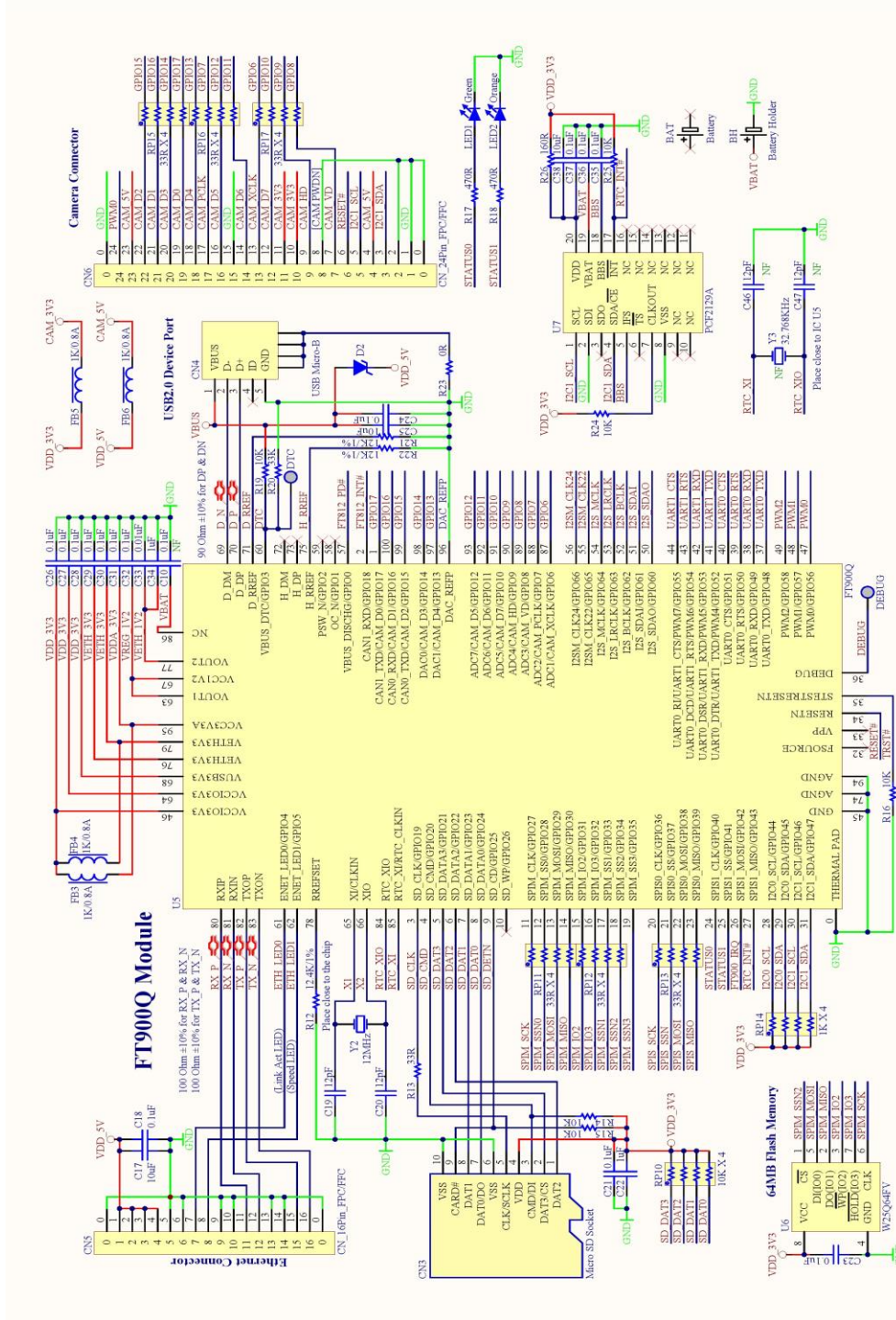

Figure 5 - Sheet 2 - FT900Q Connection

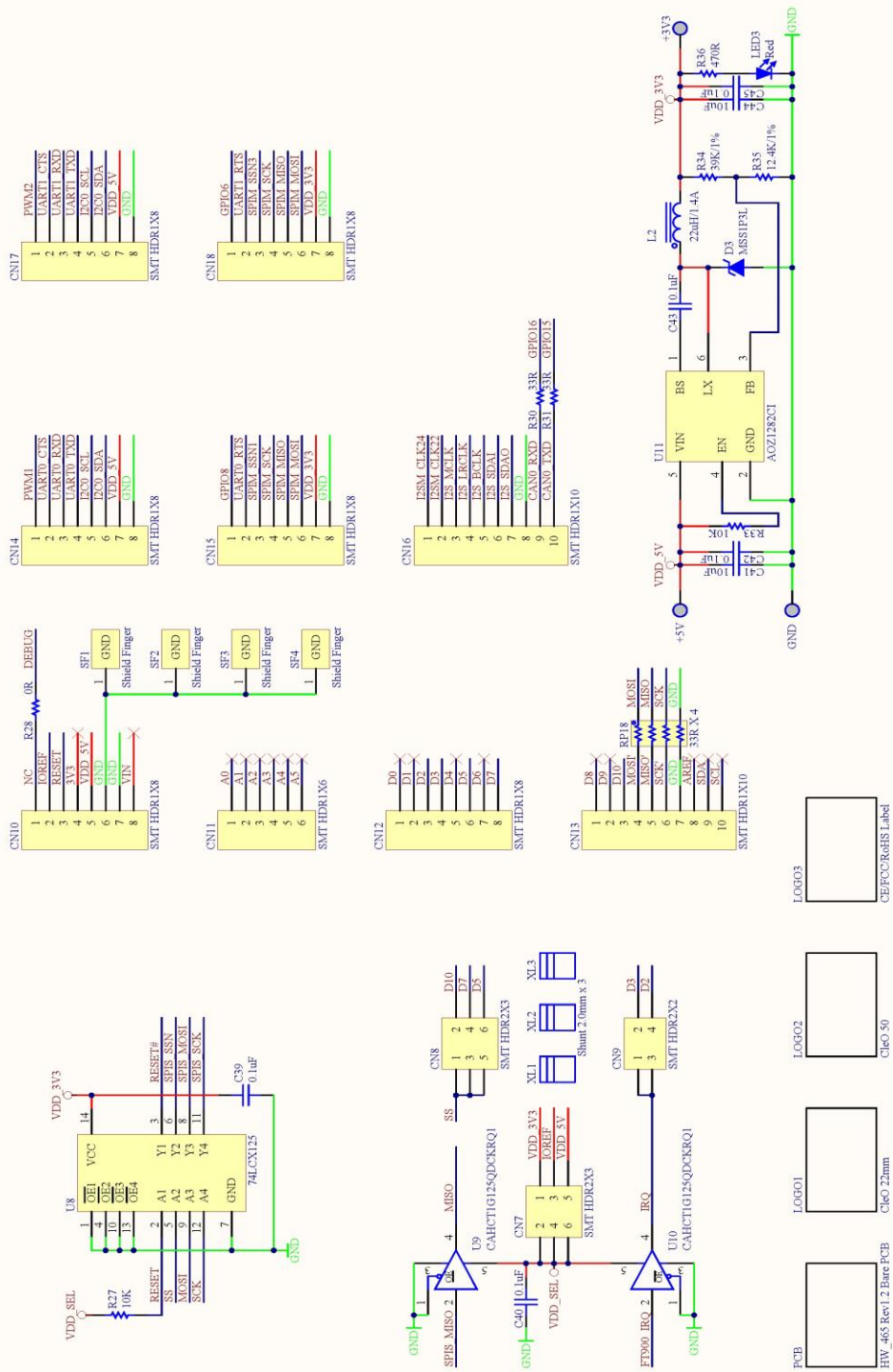

Figure 6 - Sheet 3 - Power and Connectors

7 Block Diagram

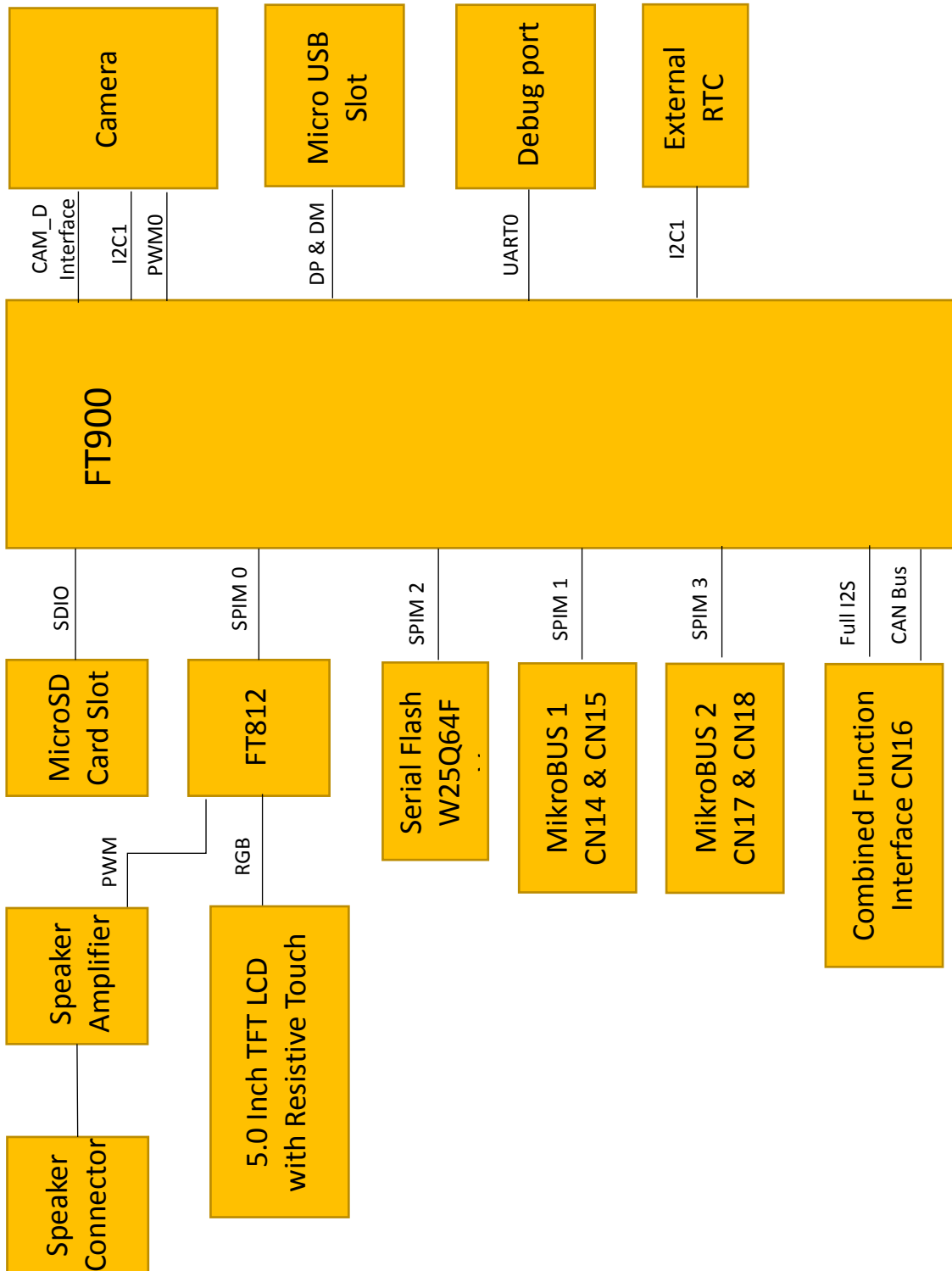

Figure 7 - CleO50 Block Diagram

8 Mechanical Dimensions

8.1 CleO50 Module Dimensions

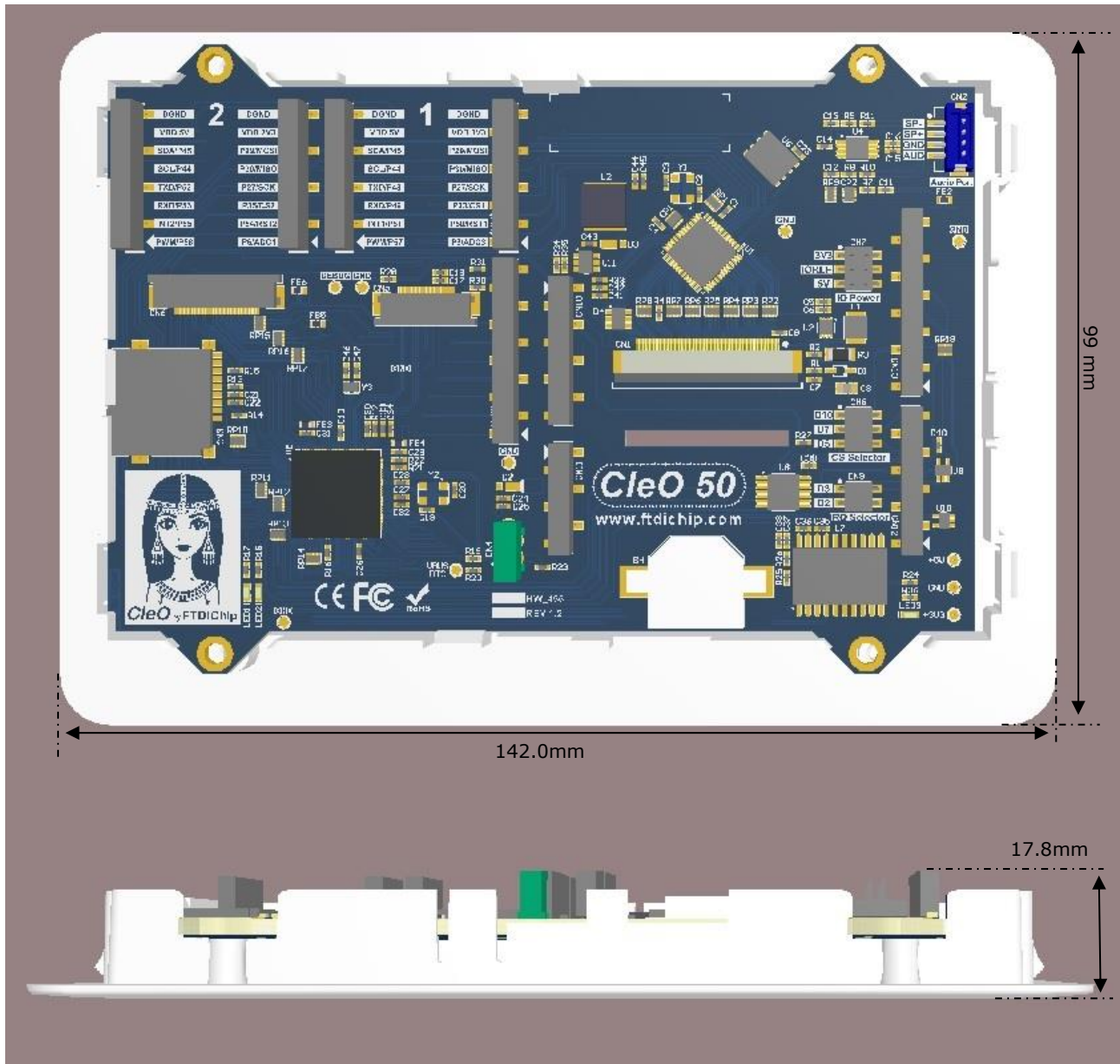

Figure 8 – CleO50 Module Dimensions

9 Contact Information

Head Office – Glasgow, UK

Future Technology Devices International Limited
Unit 1, 2 Seaward Place, Centurion Business Park
Glasgow G41 1HH
United Kingdom
Tel: +44 (0) 141 429 2777
Fax: +44 (0) 141 429 2758

E-mail (Sales) sales1@ftdichip.com
E-mail (Support) support1@ftdichip.com
E-mail (General Enquiries) admin1@ftdichip.com

Branch Office – Tigard, Oregon, USA

Future Technology Devices International Limited (USA)
7130 SW Fir Loop
Tigard, OR 97223-8160
USA
Tel: +1 (503) 547 0988
Fax: +1 (503) 547 0987

E-mail (Sales) us.sales@ftdichip.com
E-mail (Support) us.support@ftdichip.com
E-mail (General Enquiries) us.admin@ftdichip.com

Branch Office – Taipei, Taiwan

Future Technology Devices International Limited (Taiwan)
2F, No. 516, Sec. 1, NeiHu Road
Taipei 114
Taiwan, R.O.C.
Tel: +886 (0) 2 8797 1330
Fax: +886 (0) 2 8751 9737

E-mail (Sales) tw.sales1@ftdichip.com
E-mail (Support) tw.support1@ftdichip.com
E-mail (General Enquiries) tw.admin1@ftdichip.com

Branch Office – Shanghai, China

Future Technology Devices International Limited (China)
Room 1103, No. 666 West Huaihai Road,
Shanghai, 200052
China
Tel: +86 21 62351596
Fax: +86 21 62351595

E-mail (Sales) cn.sales@ftdichip.com
E-mail (Support) cn.support@ftdichip.com
E-mail (General Enquiries) cn.admin@ftdichip.com

Web Site

<http://ftdichip.com>

Distributor and Sales Representatives

Please visit the Sales Network page of the [FTDI Web site](#) for the contact details of our distributor(s) and sales representative(s) in your country.

System and equipment manufacturers and designers are responsible to ensure that their systems, and any Future Technology Devices International Ltd (FTDI) devices incorporated in their systems, meet all applicable safety, regulatory and system-level performance requirements. All application-related information in this document (including application descriptions, suggested FTDI devices and other materials) is provided for reference only. While FTDI has taken care to assure it is accurate, this information is subject to customer confirmation, and FTDI disclaims all liability for system designs and for any applications assistance provided by FTDI. Use of FTDI devices in life support and/or safety applications is entirely at the user's risk, and the user agrees to defend, indemnify and hold harmless FTDI from any and all damages, claims, suits or expense resulting from such use. This document is subject to change without notice. No freedom to use patents or other intellectual property rights is implied by the publication of this document. Neither the whole nor any part of the information contained in, or the product described in this document, may be adapted or reproduced in any material or electronic form without the prior written consent of the copyright holder. Future Technology Devices International Ltd, Unit 1, 2 Seaward Place, Centurion Business Park, Glasgow G41 1HH, United Kingdom. Scotland Registered Company Number: SC136640

Appendix A – References

Document References

For module documentations, please refer to URL below:

FT81x series datasheet: [FT81x datasheet](#)

FT90X series datasheet: [FT90X Series Datasheet](#)

FT900 tool chain installation guide : [FT900 Tool Chain Installation Guide](#)

FT900 Bootloader DFU usage guide: [FT900 Bootloader DFU Usage Application Note](#)

mikroBus: <http://www.mikroe.com/mikrobus/>

Arduino: <https://www.arduino.cc/>

CleOStuff tools: [CleOstuff](#)

Acronyms and Abbreviations

Terms	Description
DC	Direct Current
QFN	Quad-flat no-leads
LED	Light-emitting diode
MCU	MicroController Unit
VQFN	Very Thin Quad Flat Non-Leaded Package
USB	Universal Serial Bus
UART	Universal Asynchronous Receiver/Transmitter

Appendix B - List of Figures and Tables

List of Tables

Table 1 – LCD Connector Pin Out.....	9
Table 2 – Camera Connector Pin Out.....	10
Table 3 – Audio Connector Pin Out.....	11
Table 4 – CN7 Jumper Selection	12
Table 5 – CN8 Jumper Selection	12
Table 6 – CN13 Pin Out	13
Table 7 – CN12 Pin Out	13
Table 8 - MikroBUS 1 Interface Pin Out	14
Table 9 - MikroBUS 2 Interface Pin Out	14
Table 10 – CN16 Pin Out	15
Table 11 – CN10 Pin Out	15
Table 12 – CN9 Jumper Selection	16
Table 13 - Temperature Parameter	17
Table 14 – Operating Voltage and Current	17
Table 15 – Display Specification	18
Table 16 – 5.0 Inch TFT Optical Specification	18

List of Figures

Figure 1 - CleO50 Bottom View	5
Figure 2 - Power Supply	6
Figure 3 – Viewing Angle of the LCD	19
Figure 4 - Sheet 1 - FT812Q Connection.....	20
Figure 5 - Sheet 2 - FT900Q Connection.....	21
Figure 6 - Sheet 3 - Power and Connectors.....	22
Figure 7 - CleO50 Block Diagram.....	23
Figure 8 – CleO50 Module Dimensions	24
Figure 9 – CleO50 Bezel Drawing.....	25

Appendix C – Revision History

Document Title: CleO50 Module Datasheet
Document Reference No.: FT_001342
Clearance No.: BRT#045
Product Page: <http://www.ftdichip.com/Products/Modules/CleO.htm>
Document Feedback: [Send Feedback](#)

Revision	Changes	Date
Version 1.0	Initial Release	2016-10-26