

THIS DRAWING IS UNPUBLISHED. RELEASED FOR PUBLICATION JAN , 2004.  
 © COPYRIGHT 2004 By - ALL RIGHTS RESERVED.

LOC	DIST	REVISIONS			
P	LTR	DESCRIPTION	DATE	DWN	APVD
E	B	B1	REVISED PER ECO-11-005033	01APR11	RK HMR

NOTES:

- 1 SINGLE PACK IN ACCORDANCE WITH SPEC 107-3275
- 2 100 BULK PACK IN ACCORDANCE WITH SPEC 107-3275
- 3 0.08µm GOLD PLATING
- 4 0.76µm GOLD PLATING
- 5 PASSIVATED (GOLD PLATED CABLE ENTRY)
- 6 ELECTRICAL CHARACTERISTICS  
 FREQUENCY RANGE:  
   BRASS BODY: DC - 6.0GHz  
   STAINLESS STEEL (PASSIVATED): DC - 18.0GHz  
   STAINLESS STEEL (GOLD): DC - 18.0GHz  
 NOMINAL IMPEDANCE: 50 Ohm  
 INSULATION RESISTANCE: 5000 MOhm  
 WORKING VOLTAGE: 500 Volts RMS at Sea Level  
 DIELECTRIC WITHSTAND VOLTAGE: 1500 Volts RMS Max  
 CONTACT RESISTANCE:  
   CENTRE CONTACT: 3 mOhm Max  
   OUTER CONTACT: 2 mOhm Max  
 VSWR @ 4GHz: 1.35:1  
 INSERTION LOSS dB @ x 1.5 GHz: 0.06 Max
- 7 MECHANICAL CHARACTERISTICS  
 COUPLING NUT RETENTION FORCE: 267N  
 CABLE RETENTION FORCE: 110N Min  
 CLAMP NUT RECOMMENDED TORQUE: 80-110N  
 DURABILITY: 500 Cycles Min
- 8 ENVIRONMENTAL CHARACTERISTICS  
 OPERATING TEMPERATURE: -65 to +165 DegC
- 9 FOR TECHNICAL DATA REFER TO YOUR LOCAL TE CONNECTIVITY SALES OFFICE
- 10 ALL DIMENSIONS ARE NOMINAL FOR REFERENCE ONLY UNLESS OTHERWISE STATED

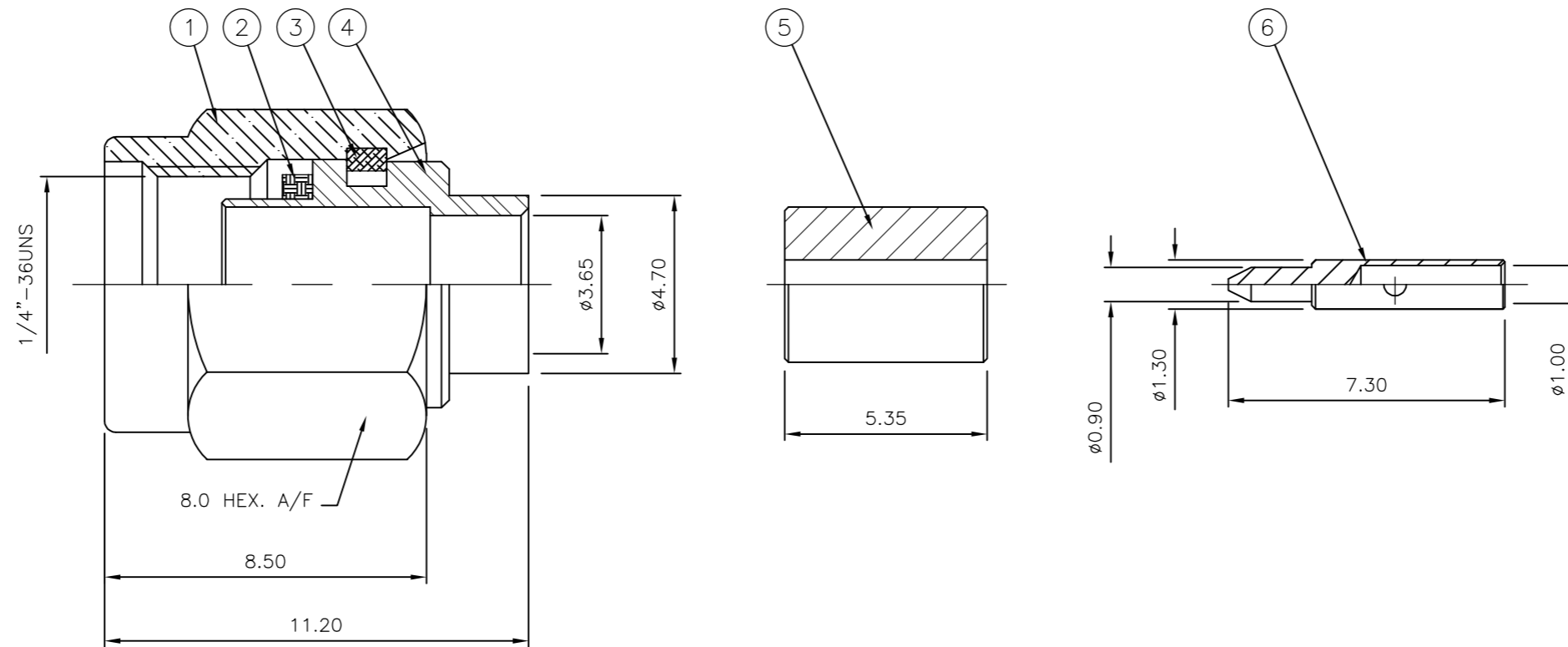

QTY	QTY PER ASSY	QTY PER ASSY	QTY PER ASSY	QTY PER ASSY	QTY PER ASSY	QTY PER ASSY	QTY PER ASSY	QTY PER ASSY	QTY PER ASSY	MATERIAL	DESCRIPTION	ITEM
1	1	1	1	1	1	1	1	1	1	BRASS	▲ CENTER CONTACT	6
1	1	1	1	1	1	1	1	1	1	PTFE	INSULATOR	5
1	1	-	-	-	-	-	-	-	-	BRASS	▲ BODY	4
-	-	1	1	-	-	-	-	-	-	STAINLESS STEEL	▲ BODY	4
-	-	-	-	-	-	1	1	-	-	STAINLESS STEEL	▲ BODY	4
1	1	1	1	1	1	1	1	1	1	STAINLESS STEEL	CIRCLIP	3
1	1	1	1	1	1	1	1	1	1	SILICON	GASKET	2
1	1	-	-	-	-	-	-	-	-	BRASS	▲ SHELL	1
-	-	1	1	-	-	-	-	-	-	STAINLESS STEEL	▲ SHELL	1
-	-	-	-	1	1	-	-	-	-	STAINLESS STEEL	▲ SHELL	1
3--1	3--0	2--1	2--0	1--1	1--0	-	-	-	-	MATERIAL	DESCRIPTION	ITEM

THIS DRAWING IS A CONTROLLED DOCUMENT.		DWN R.SMITH 28JAN04	TE Connectivity	
DIMENSIONS: mm		CHK S.PARLOW 28JAN04	NAME SMA STRAIGHT PLUG DIRECT SOLDER NON CAPTIVE CENTRE CONTACT RG402/U	
TOLERANCES UNLESS OTHERWISE SPECIFIED		APVD F.WHEELER-KING 28JAN04	DRAWING NO A2 00779 C=1478903	
0 PLC ± 1 PLC ± 2 PLC ± 3 PLC ± 4 PLC ± ANGLES ±		PRODUCT SPEC APPLICATION SPEC	RESTRICTED TO	
MATERIAL SEE TABLE		WEIGHT -	SCALE NTS	
		CUSTOMER DRAWING		SHEET 1 OF 2
				REV B1

THIS DRAWING IS UNPUBLISHED. RELEASED FOR PUBLICATION JAN , 2004.  
 © COPYRIGHT 2004 By - ALL RIGHTS RESERVED.

LOC		DIST		REVISIONS			
P	LTR	DESCRIPTION		DATE	DWN	APVD	
-	-	SEE SHEET 1		-	-	-	

COMPONENTS

MAIN BODY (ITEM 1,2,3,4)

DIELECTRIC (ITEM 5)

CENTRE CONTACT (ITEM 6)

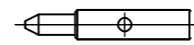
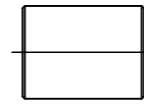
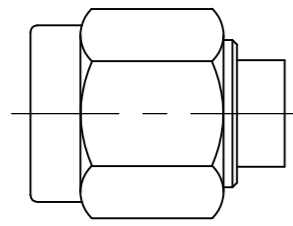

ASSEMBLY INSTRUCTIONS  
RG402/U

STEP 1: PREPARATION OF CABLE

1. INSERT SQUARED CABLE END INTO FIXTURE BASE HOLE PATTERN No. 2
2. PLACE SAW IN SAW SLOT AND CUT THROUGH OUTER CONDUCTOR AND INTO DIELECTRIC WHILST ROTATING CABLE
3. REMOVE CABLE FROM FIXTURE AND FINISH CUTTING DIELECTRIC WITH CUTTING BLADE
4. BARE INNER CONDUCTOR BY PRYING CUT OUTER CONDUCTOR AND DIELECTRIC FROM CABLE
5. TRIM CABLE INNER CONDUCTOR TO LENGTH

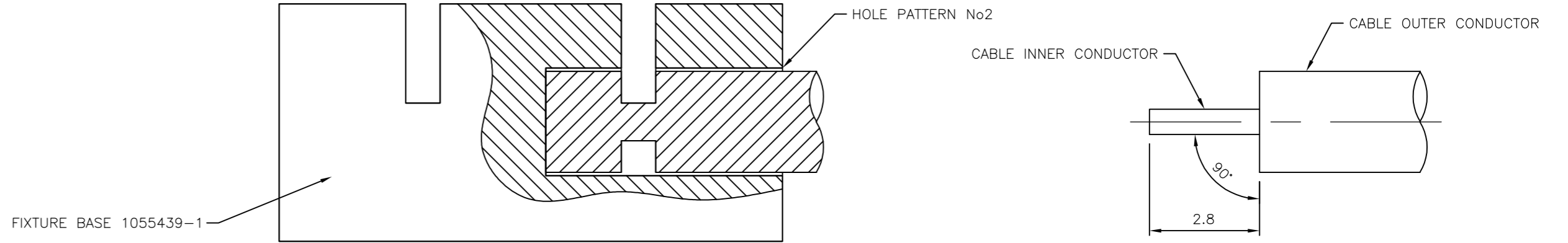

STEP 2: SOLDERING OF CENTRE CONTACT TO CABLE

1. TIN INNER CONDUCTOR OF CABLE
2. PLACE SOLDER GAUGE ON INNER CONDUCTOR FLUSH WITH END OF OUTER CONTACT
3. PLACE CENTRE CONTACT IN HOLDER. HEAT CENTRE CONTACT AND PUSH IT OVER INNER CONDUCTOR OF CABLE TO REST FIRMLY AGAIN SOLDER GAUGE
4. REMOVER SOLDER GAUGE AND EXCESS SOLDER

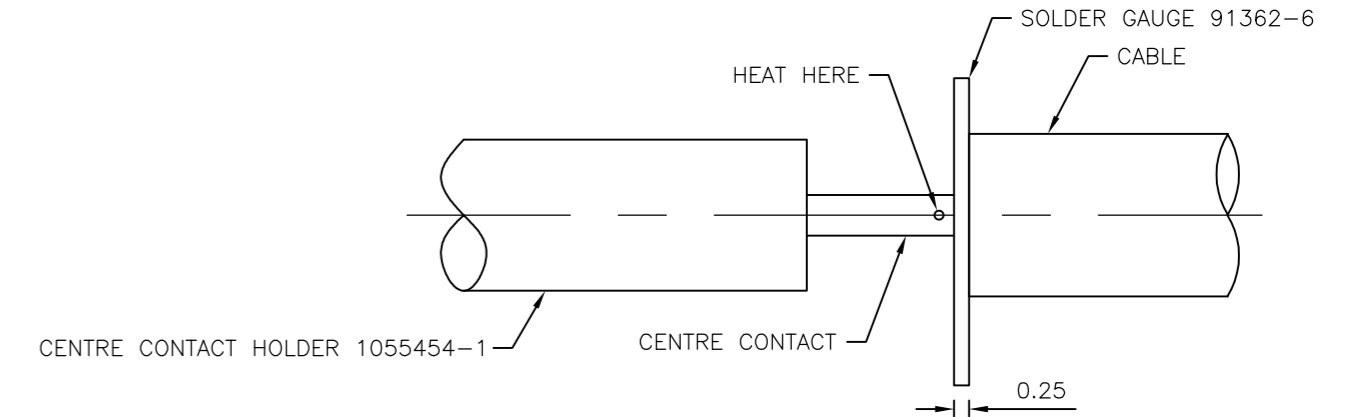

STEP 3: SOLDERING OF CABLE TO HOUSING

1. SCREW HOUSING ASSEMBLY ONTO LOCATOR TOOL
2. CAREFULLY INSERT CABLE ASSEMBLY INTO PRE-ASSEMBLED HOUSING DIELECTRIC OF HOUSING ASSEMBLY
3. PLACE LOOSE ASSEMBLY IN FIXTURE BASE AS SHOWN
4. BOTTOM LOCATOR TOOL AGAIN FIXTURE BASE AS SHOWN
5. MAINTAINING PRESSURE ON CABLE TO KEEP LOCATOR TOOL BOTTOMED TIGHTEN CLAMP SCREW TO SECURE CABLE
6. SOLDER CABLE TO HOUSING

NOTE: FIXTURE SHOULD BE CLAMPED VERTICALLY IN VICE (SO THAT CONNECTOR INTERFACE IS FACING DOWN)

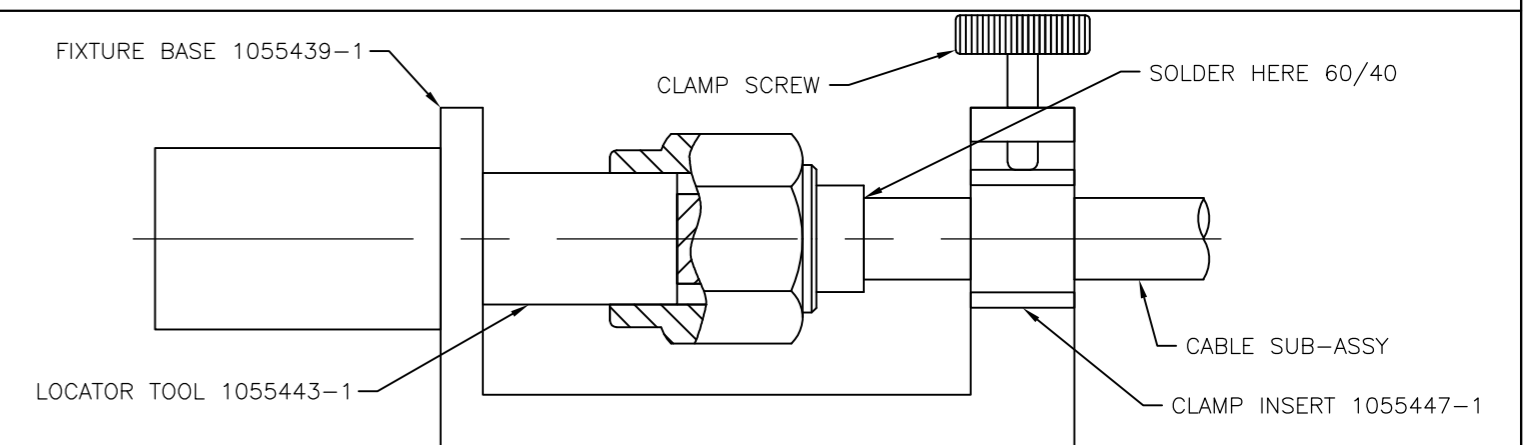

STEP 4: PRESSING OF DIELECTRIC INTO HOUSING SUB-ASSEMBLY

1. THREAD INSERT TOOL INTO HOUSING SUB-ASSEMBLY
2. INSERT DIELECTRIC INTO INSERT TOOL HOUSING
3. PLACE INSERT TOOL PLUNGER INTO POSITION AND PRESS UNTIL FLANGE BOTTOMS ON TOOL HOUSING
4. ASSEMBLY IS NOW COMPLETE

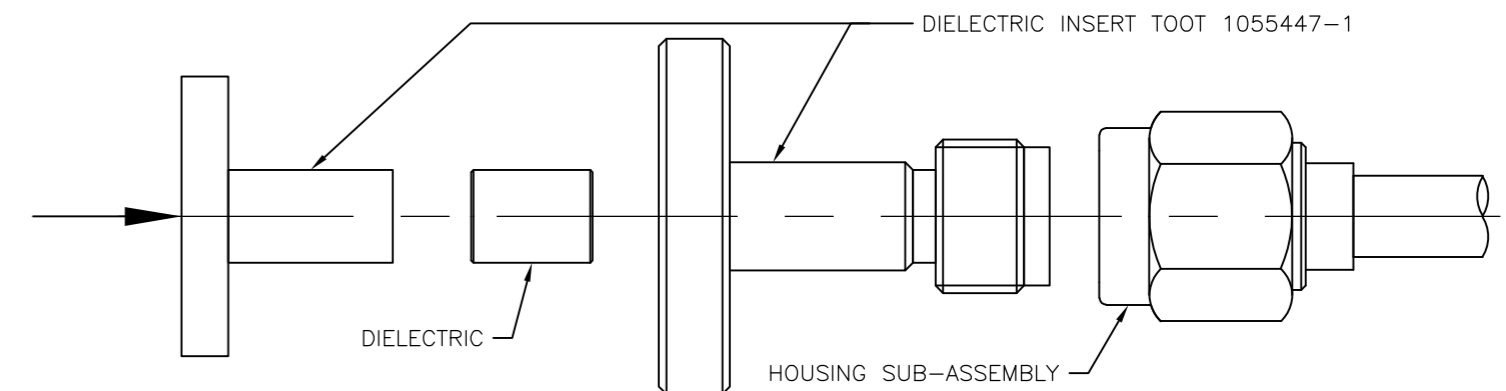

NOTES: INTERFACE DIMENSIONS PER MIL-STD-384A-310-1

THIS DRAWING IS A CONTROLLED DOCUMENT.		DWN	R.SMITH	28JAN04		TE Connectivity																
DIMENSIONS: mm		CHK	S.PARLOW	28JAN04		NAME																
		APVD	F.WHEELER-KING	28JAN04		SMA STRAIGHT PLUG DIRECT SOLDER NON CAPTIVE CENTRE CONTACT RG402/U																
<p>TOLERANCES UNLESS OTHERWISE SPECIFIED</p> <table border="1"> <tr><td>0 PLC</td><td>±</td></tr> <tr><td>1 PLC</td><td>±</td></tr> <tr><td>2 PLC</td><td>±</td></tr> <tr><td>3 PLC</td><td>±</td></tr> <tr><td>4 PLC</td><td>±</td></tr> <tr><td>ANGLES</td><td>±</td></tr> <tr><td>FINISH</td><td>-</td></tr> </table>		0 PLC	±	1 PLC		±	2 PLC	±	3 PLC	±	4 PLC	±	ANGLES	±	FINISH	-	PRODUCT SPEC	APPLICATION SPEC		SIZE	CAGE CODE	DRAWING NO
0 PLC	±																					
1 PLC	±																					
2 PLC	±																					
3 PLC	±																					
4 PLC	±																					
ANGLES	±																					
FINISH	-																					
MATERIAL SEE TABLE		WEIGHT	-		A2	00779	C=1478903	-														
CUSTOMER DRAWING					SCALE	NTS	SHEET	2 OF 2														
					REV	B1																

1478903

A