

**FEATURES:**

- Enhanced N channel FET with no inherent diode to Vcc
- 5Ω bidirectional switches connect inputs to outputs
- Pin compatible with the 74F245, 74FCT245, and 74FCT245T
- Low power CMOS proprietary technology
- Zero propagation delay, zero ground bounce
- Undershoot clamp diodes on all switch and control inputs
- 25Ω resistors for low noise
- TTL-compatible control inputs
- Available in QSOP and TSSOP packages

**APPLICATIONS:**

- Hot-swapping, hot-docking
- Voltage translation (5V to 3.3V)
- Power conservation
- Capacitance reduction and isolation
- Logic replacement (data processing)
- Clock gating
- Bus switching and isolation

**DESCRIPTION:**

The QS32245 provides a set of eight high-speed CMOS TTL-compatible bus switches in a pinout compatible with 74FCT245, 74F245, 74ALS/AS/LS245 8-bit transceivers. The Output Enable ( $\overline{OE}$ ) signal turns the switches on similar to the  $\overline{OE}$  signal of the 74'245. The QS32245 has 25Ω series resistors to reduce ground bounce noise.

QuickSwitch devices provide an order of magnitude faster speed than conventional logic devices.

The QS32245 is characterized for operation at -40°C to +85°C.

**FUNCTIONAL BLOCK DIAGRAM**

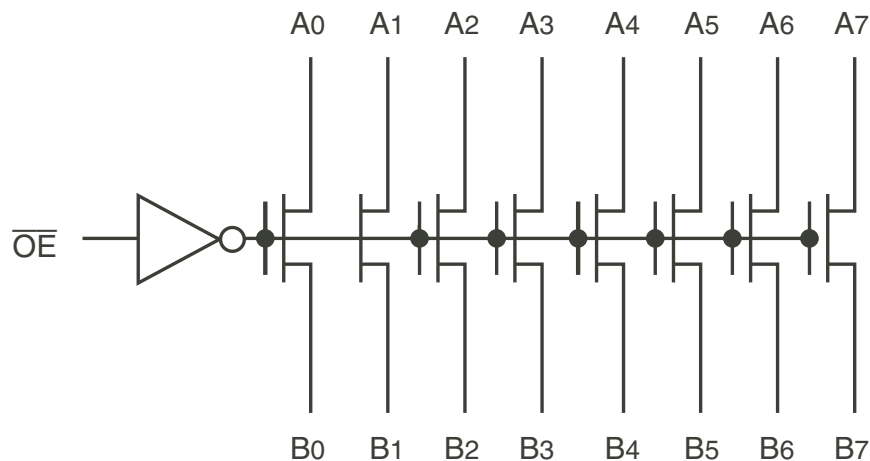

PIN CONFIGURATION

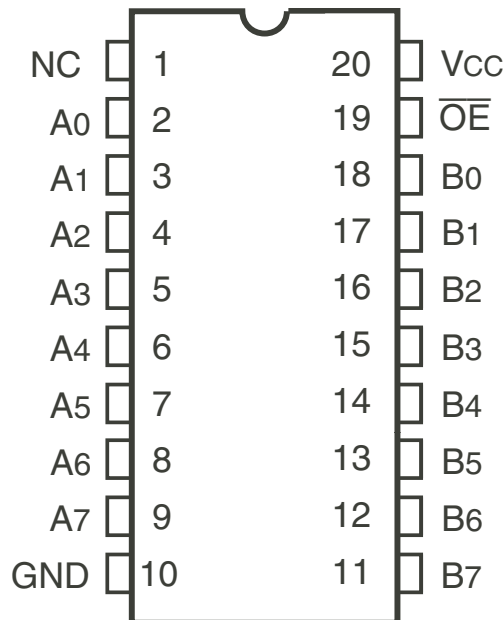

TOP VIEW

Package Type	Package Code	Order Code
TSSOP	PGG20	PAG
QSOP	PCG20	QG

ABSOLUTE MAXIMUM RATINGS(1)

Symbol	Description	Max	Unit
VTERM <sup>(2)</sup>	Supply Voltage to Ground	-0.5 to +7	V
VTERM <sup>(3)</sup>	DC Switch Voltage Vs	-0.5 to +7	V
VTERM <sup>(3)</sup>	DC Input Voltage VIN	-0.5 to +7	V
VAC	AC Input Voltage (pulse width ≤ 20ns)	-3	V
IOUT	DC Output Current	120	mA
PMAX	Maximum Power Dissipation (TA = 85°C)	0.5	W
TSTG	Storage Temperature	-65 to +150	°C

NOTE:

1. Stresses greater than those listed under ABSOLUTE MAXIMUM RATINGS may cause permanent damage to the device. This is a stress rating only and functional operation of the device at these or any other conditions above those indicated in the operational sections of this specification is not implied. Exposure to absolute maximum rating conditions for extended periods may affect reliability.
2. Vcc terminals.
3. All terminals except Vcc.

CAPACITANCE

(TA = +25°C, f = 1.0MHz, VIN = 0V, VOUT = 0V)

Pins	Typ.	Max. <sup>(1)</sup>	Unit
Control Pins	3	5	pF
Quickswitch Channels (Switch OFF)	5	7	pF

NOTE:

1. This parameter is measured at characterization but not tested.

PIN DESCRIPTION

Pin Names	Description
$\overline{OE}$	Output Enable
An	Data I/Os
Bn	Data I/Os

FUNCTION TABLE(1)

$\overline{OE}$	Outputs
H	Disconnected
L	An = Bn

NOTE:

1. H = HIGH Voltage Level  
L = LOW Voltage Level

## DC ELECTRICAL CHARACTERISTICS OVER OPERATING RANGE

Following Conditions Apply Unless Otherwise Specified:

Industrial:  $T_A = -40^{\circ}\text{C}$  to  $+85^{\circ}\text{C}$ ,  $V_{CC} = 5.0\text{V} \pm 5\%$

Symbol	Parameter	Test Conditions	Min.	Typ. <sup>(1)</sup>	Max.	Unit
$V_{IH}$	Input HIGH Level	Guaranteed Logic HIGH for Control Pins	2	—	—	V
$V_{IL}$	Input LOW Level	Guaranteed Logic LOW for Control Pins	—	—	0.8	V
$I_{IN}$	Input Leakage Current (Control Inputs) <sup>(2)</sup>	$0\text{V} \leq V_{IN} \leq V_{CC}$	—	—	$\pm 1$	$\mu\text{A}$
$I_{OZ}$	Off-State Output Current (Hi-Z)	$0\text{V} \leq V_{OUT} \leq V_{CC}$ , Switches OFF	—	$\pm 0.001$	$\pm 1$	$\mu\text{A}$
$R_{ON}^{(3)}$	Switch ON Resistance	$V_{CC} = \text{Min.}, V_{IN} = 0\text{V}, I_{ON} = 30\text{mA}$	18	23	35	$\Omega$
		$V_{CC} = \text{Min.}, V_{IN} = 2.4\text{V}, I_{ON} = 15\text{mA}$	18	25	40	
$V_P$	Pass Voltage <sup>(2)</sup>	$V_{IN} = V_{CC} = 5\text{V}, I_{OUT} = -5\mu\text{A}$	3.7	4	4.2	V

NOTES:

1. Typical values are at  $V_{CC} = 5.0\text{V}$ ,  $T_A = 25^{\circ}\text{C}$ .
2. Pass Voltage is guaranteed but not production tested.
3.  $R_{OUT}$  changed on March 8, 2002. See rear page for more information.

### TYPICAL ON RESISTANCE vs $V_{IN}$ AT $V_{CC} = 5\text{V}$

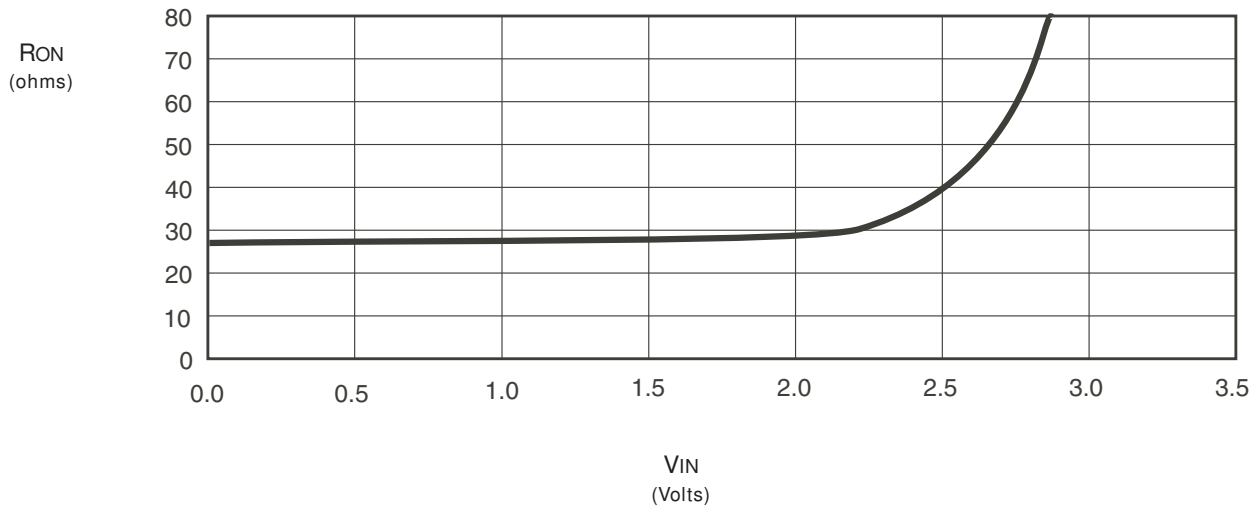

## POWER SUPPLY CHARACTERISTICS

Symbol	Parameter	Test Conditions <sup>(1)</sup>	Max.	Unit
I <sub>CCQ</sub>	Quiescent Power Supply Current	V <sub>CC</sub> = Max., V <sub>IN</sub> = GND or V <sub>CC</sub> , f = 0	3	μA
ΔI <sub>CC</sub>	Power Supply Current per Control Input HIGH <sup>(2)</sup>	V <sub>CC</sub> = Max., V <sub>IN</sub> = 3.4V, f = 0	1.5	mA
I <sub>CCD</sub>	Dynamic Power Supply Current per MHz <sup>(3)</sup>	V <sub>CC</sub> = Max., A and B pins open Control Inputs Toggling at 50% Duty Cycle	0.25	mA/MHz

**NOTES:**

- For conditions shown as Min. or Max., use the appropriate values specified under DC Electrical Characteristics.
- Per TLL driven input (V<sub>IN</sub> = 3.4V, control inputs only). A and B pins do not contribute to ΔI<sub>CC</sub>.
- This current applies to the control inputs only and represents the current required to switch internal capacitance at the specified frequency. The A and B inputs generate no significant AC or DC currents as they transition. This parameter is guaranteed but not production tested.

## SWITCHING CHARACTERISTICS OVER OPERATING RANGE

T<sub>A</sub> = -40°C to +85°C, V<sub>CC</sub> = 5.0V ± 5%;

C<sub>LOAD</sub> = 50pF, R<sub>LOAD</sub> = 500Ω unless otherwise noted.

Symbol	Parameter	Min. <sup>(1)</sup>	Typ.	Max.	Unit
t <sub>PLH</sub>	Data Propagation Delay <sup>(2,3)</sup>	—	—	1.25	ns
t <sub>PHL</sub>	An to/from Bn				
t <sub>PZL</sub>	Switch Turn-on Delay	0.5	—	6.6	ns
t <sub>PZH</sub>	$\overline{OE}$ to An/Bn				
t <sub>PLZ</sub>	Switch Turn-off Delay <sup>(2)</sup>	0.5	—	4.5	ns
t <sub>PHZ</sub>	$\overline{OE}$ to An/Bn				

**NOTES:**

- Minimums are guaranteed but not production tested.
- This parameter is guaranteed but not production tested.
- The bus switch contributes no propagation delay other than the RC delay of the ON resistance of the switch and the load capacitance. The time constant for the switch alone is of the order of 1.25ns for C<sub>L</sub> = 50pF. Since this time constant is much smaller than the rise and fall times of typical driving signals, it adds very little propagation delay to the system. Propagation delay of the bus switch, when used in a system, is determined by the driving circuit on the driving side of the switch and its interaction with the load on the driven side.

## ORDERING INFORMATION

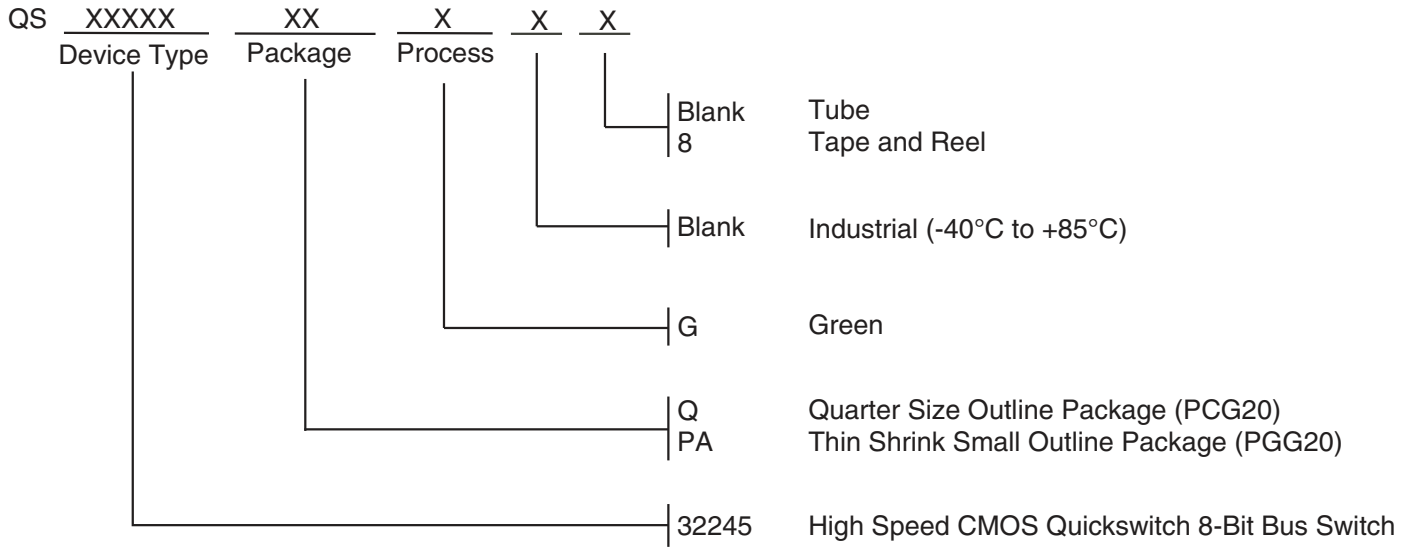

## Orderable Part Information

Speed (ns)	Orderable Part ID	Pkg. Code	Pkg. Type	Temp. Grade
	QS32245PAG	PGG20	TSSOP	I
	QS32245PAG8	PGG20	TSSOP	I
	QS32245QG	PCG20	QSOP	I
	QS32245QG8	PCG20	QSOP	I

## Datasheet Document History

02/09/2011	Pg. 5	Updated the ordering information by removing the "IDT" notation, non RoHS part and by adding Tape and Reel information.
06/03/2019	Pg.2,5	Added table under pin configuration diagram with detailed package information and orderable part information table. Updated the ordering information diagram in clearer detail.

## IMPORTANT NOTICE AND DISCLAIMER

RENESAS ELECTRONICS CORPORATION AND ITS SUBSIDIARIES (“RENESAS”) PROVIDES TECHNICAL SPECIFICATIONS AND RELIABILITY DATA (INCLUDING DATASHEETS), DESIGN RESOURCES (INCLUDING REFERENCE DESIGNS), APPLICATION OR OTHER DESIGN ADVICE, WEB TOOLS, SAFETY INFORMATION, AND OTHER RESOURCES “AS IS” AND WITH ALL FAULTS, AND DISCLAIMS ALL WARRANTIES, EXPRESS OR IMPLIED, INCLUDING, WITHOUT LIMITATION, ANY IMPLIED WARRANTIES OF MERCHANTABILITY, FITNESS FOR A PARTICULAR PURPOSE, OR NON-INFRINGEMENT OF THIRD PARTY INTELLECTUAL PROPERTY RIGHTS.

These resources are intended for developers skilled in the art designing with Renesas products. You are solely responsible for (1) selecting the appropriate products for your application, (2) designing, validating, and testing your application, and (3) ensuring your application meets applicable standards, and any other safety, security, or other requirements. These resources are subject to change without notice. Renesas grants you permission to use these resources only for development of an application that uses Renesas products. Other reproduction or use of these resources is strictly prohibited. No license is granted to any other Renesas intellectual property or to any third party intellectual property. Renesas disclaims responsibility for, and you will fully indemnify Renesas and its representatives against, any claims, damages, costs, losses, or liabilities arising out of your use of these resources. Renesas' products are provided only subject to Renesas' Terms and Conditions of Sale or other applicable terms agreed to in writing. No use of any Renesas resources expands or otherwise alters any applicable warranties or warranty disclaimers for these products.

(Disclaimer Rev.1.0 Mar 2020)

### Corporate Headquarters

TOYOSU FORESIA, 3-2-24 Toyosu,  
Koto-ku, Tokyo 135-0061, Japan  
[www.renesas.com](http://www.renesas.com)

### Contact Information

For further information on a product, technology, the most up-to-date version of a document, or your nearest sales office, please visit:  
[www.renesas.com/contact/](http://www.renesas.com/contact/)

### Trademarks

Renesas and the Renesas logo are trademarks of Renesas Electronics Corporation. All trademarks and registered trademarks are the property of their respective owners.