

# Renesas Synergy™

Starter Kit SK-S7G2

User's Manual

Synergy S7G2 MCU

All information contained in these materials, including products and product specifications, represents information on the product at the time of publication and is subject to change by Renesas Electronics Corp. without notice. Please review the latest information published by Renesas Electronics Corp. through various means, including the Renesas Electronics Corp. website (<http://www.renesas.com>).

## Notice

1. Descriptions of circuits, software and other related information in this document are provided only to illustrate the operation of semiconductor products and application examples. You are fully responsible for the incorporation of these circuits, software, and information in the design of your equipment. Renesas Electronics assumes no responsibility for any losses incurred by you or third parties arising from the use of these circuits, software, or information.
2. Renesas Electronics has used reasonable care in preparing the information included in this document, but Renesas Electronics does not warrant that such information is error free. Renesas Electronics assumes no liability whatsoever for any damages incurred by you resulting from errors in or omissions from the information included herein.
3. Renesas Electronics does not assume any liability for infringement of patents, copyrights, or other intellectual property rights of third parties by or arising from the use of Renesas Electronics products or technical information described in this document. No license, express, implied or otherwise, is granted hereby under any patents, copyrights or other intellectual property rights of Renesas Electronics or others.
4. You should not alter, modify, copy, or otherwise misappropriate any Renesas Electronics product, whether in whole or in part. Renesas Electronics assumes no responsibility for any losses incurred by you or third parties arising from such alteration, modification, copy or otherwise misappropriation of Renesas Electronics product.
5. Renesas Electronics products are classified according to the following two quality grades: "Standard" and "High Quality". The recommended applications for each Renesas Electronics product depends on the product's quality grade, as indicated below.  
"Standard": Computers; office equipment; communications equipment; test and measurement equipment; audio and visual equipment; home electronic appliances; machine tools; personal electronic equipment; and industrial robots etc.  
"High Quality": Transportation equipment (automobiles, trains, ships, etc.); traffic control systems; anti-disaster systems; anti-crime systems; and safety equipment etc.  

Renesas Electronics products are neither intended nor authorized for use in products or systems that may pose a direct threat to human life or bodily injury (artificial life support devices or systems, surgical implantations etc.), or may cause serious property damages (nuclear reactor control systems, military equipment etc.). You must check the quality grade of each Renesas Electronics product before using it in a particular application. You may not use any Renesas Electronics product for any application for which it is not intended. Renesas Electronics shall not be in any way liable for any damages or losses incurred by you or third parties arising from the use of any Renesas Electronics product for which the product is not intended by Renesas Electronics.
6. You should use the Renesas Electronics products described in this document within the range specified by Renesas Electronics, especially with respect to the maximum rating, operating supply voltage range, movement power voltage range, heat radiation characteristics, installation and other product characteristics. Renesas Electronics shall have no liability for malfunctions or damages arising out of the use of Renesas Electronics products beyond such specified ranges.
7. Although Renesas Electronics endeavors to improve the quality and reliability of its products, semiconductor products have specific characteristics such as the occurrence of failure at a certain rate and malfunctions under certain use conditions. Further, Renesas Electronics products are not subject to radiation resistance design. Please be sure to implement safety measures to guard them against the possibility of physical injury, and injury or damage caused by fire in the event of the failure of a Renesas Electronics product, such as safety design for hardware and software including but not limited to redundancy, fire control and malfunction prevention, appropriate treatment for aging degradation or any other appropriate measures. Because the evaluation of microcomputer software alone is very difficult, please evaluate the safety of the final products or systems manufactured by you.
8. Please contact a Renesas Electronics sales office for details as to environmental matters such as the environmental compatibility of each Renesas Electronics product. Please use Renesas Electronics products in compliance with all applicable laws and regulations that regulate the inclusion or use of controlled substances, including without limitation, the EU RoHS Directive. Renesas Electronics assumes no liability for damages or losses occurring as a result of your noncompliance with applicable laws and regulations.
9. Renesas Electronics products and technology may not be used for or incorporated into any products or systems whose manufacture, use, or sale is prohibited under any applicable domestic or foreign laws or regulations. You should not use Renesas Electronics products or technology described in this document for any purpose relating to military applications or use by the military, including but not limited to the development of weapons of mass destruction. When exporting the Renesas Electronics products or technology described in this document, you should comply with the applicable export control laws and regulations and follow the procedures required by such laws and regulations.
10. It is the responsibility of the buyer or distributor of Renesas Electronics products, who distributes, disposes of, or otherwise places the product with a third party, to notify such third party in advance of the contents and conditions set forth in this document, Renesas Electronics assumes no responsibility for any losses incurred by you or third parties as a result of unauthorized use of Renesas Electronics products.
11. This document may not be reproduced or duplicated in any form, in whole or in part, without prior written consent of Renesas Electronics.
12. Please contact a Renesas Electronics sales office if you have any questions regarding the information contained in this document or Renesas Electronics products, or if you have any other inquiries.

(Note 1) "Renesas Electronics" as used in this document means Renesas Electronics Corporation and also includes its majority-owned subsidiaries.

(Note 2) "Renesas Electronics product(s)" means any product developed or manufactured by or for Renesas Electronics.

# Table of Contents

1. Overview .....	1
1.1 Features .....	1
1.2 In the box .....	1
1.3 Block diagram.....	2
1.4 Hardware features .....	2
1.5 Resources .....	2
2. Getting Started .....	3
3. Power Supply Requirements.....	4
3.1 Power supply.....	4
3.2 Power-up behavior.....	4
3.3 Microcontroller current.....	4
4. Board Components.....	6
4.1 J-Link On-Board debugger.....	6
4.2 LCD .....	6
4.3 Ethernet .....	7
4.4 Pmod Compatible interfaces .....	7
4.5 CAN, RS-232/485.....	8
4.6 USB Device port.....	9
4.7 USB Host port.....	9
4.8 Capacitive touch interface.....	9
4.9 Audio .....	10
4.10 User buttons and LEDs .....	10
4.11 QSPI flash .....	10
4.12 Arduino Shield interface .....	11
4.13 Breakout headers.....	11
5. Board Layout .....	13
6. Configuration.....	14
6.1 RS-232 transceiver configuration .....	14
7. Connectivity .....	15
7.1 USB Host port.....	15
7.2 USB Device port.....	15
7.3 Ethernet.....	15
7.4 LCD .....	16
7.5 Pmod Compatible ports.....	17
7.6 JTAG/SWD.....	18
7.7 UART & CAN .....	18
8. Pin Connections .....	20

## 1. Overview

### 1.1 Features

The SK-S7G2 is a single-board starter kit for the Renesas Synergy S7G2 microcontroller in a 176-pin LQFP package. The board provides easy-to-access interfaces to the peripherals of the S7G2 microcontroller for application development.

The SK-S7G2 includes four header connectors for direct access to the S7G2 microcontroller I/O pins. Additionally, the board includes connectors for USB, Ethernet, RS-232/485, CAN, and JTAG J-Link interfaces.

The SK-S7G2 includes a 2.4-in. QVGA (240 x 320) TFT display with capacitive touch screen.

As a starter kit, the SK-S7G2 is designed to demonstrate the main features of the Synergy Platform using the S7G2 device. It is an initial evaluation platform that you can use to determine which development kit is appropriate for further development of your product.

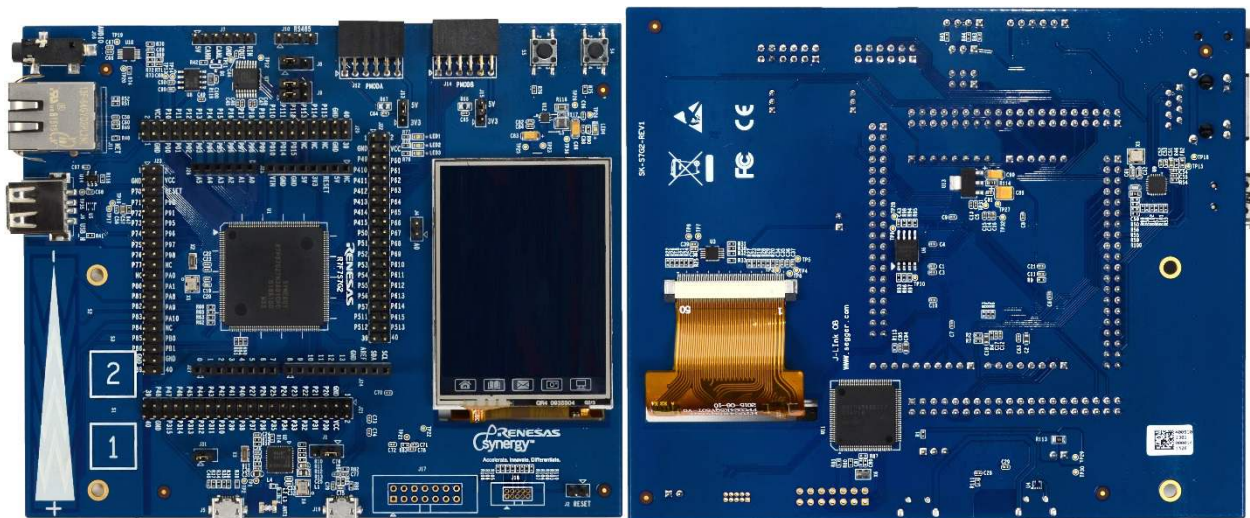

Figure 1: SK-S7G2

### 1.2 In the box

The following components are included in the SK-S7G2:

- SK-S7G2 board
- 3-foot USB Type-A to Micro-B cable for debugger and power connection
- Quick Start Guide

### 1.3 Block diagram

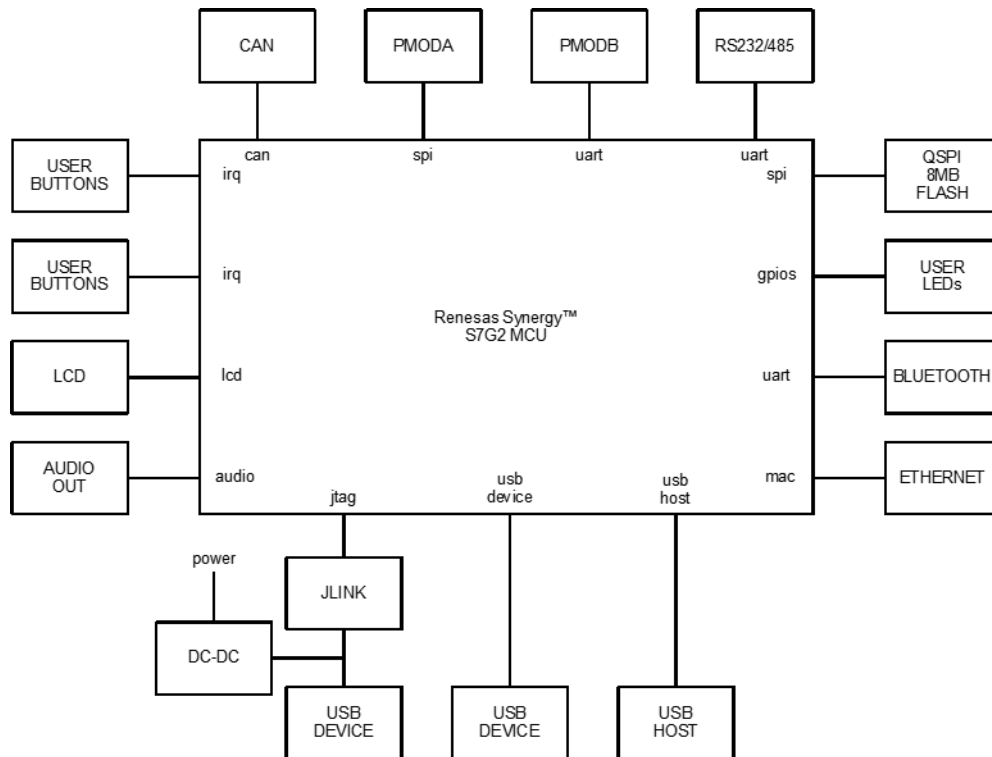

Figure 2: SK-S7G2 block diagram

### 1.4 Hardware features

The SK-S7G2 contains the following hardware:

- S7G2 microprocessor with 176 LQFP package
- Four connectors that provide access to all S7G2 microprocessor signals
- Low cost QVGA TFT touch screen
- Three user LEDs
- Arduino Shield Uno compatible socket
- Two mechanical switches connected directly to microprocessor interrupt pins
- Two capacitive touch-buttons connected to pins that can generate interrupts
- One capacitive slider
- Audio output
- QSPI memory (8 MB)
- SPI, IIC, CAN, and SCI interface

### 1.5 Resources

The following documents are related to S7G2 and SK-S7G2 hardware:

- SK-S7G2 Quick Start Guide
- SK-S7G2 Board Schematics
- S7G2 User's Manual: Hardware
- S7G2 Data sheet

## 2. Getting Started

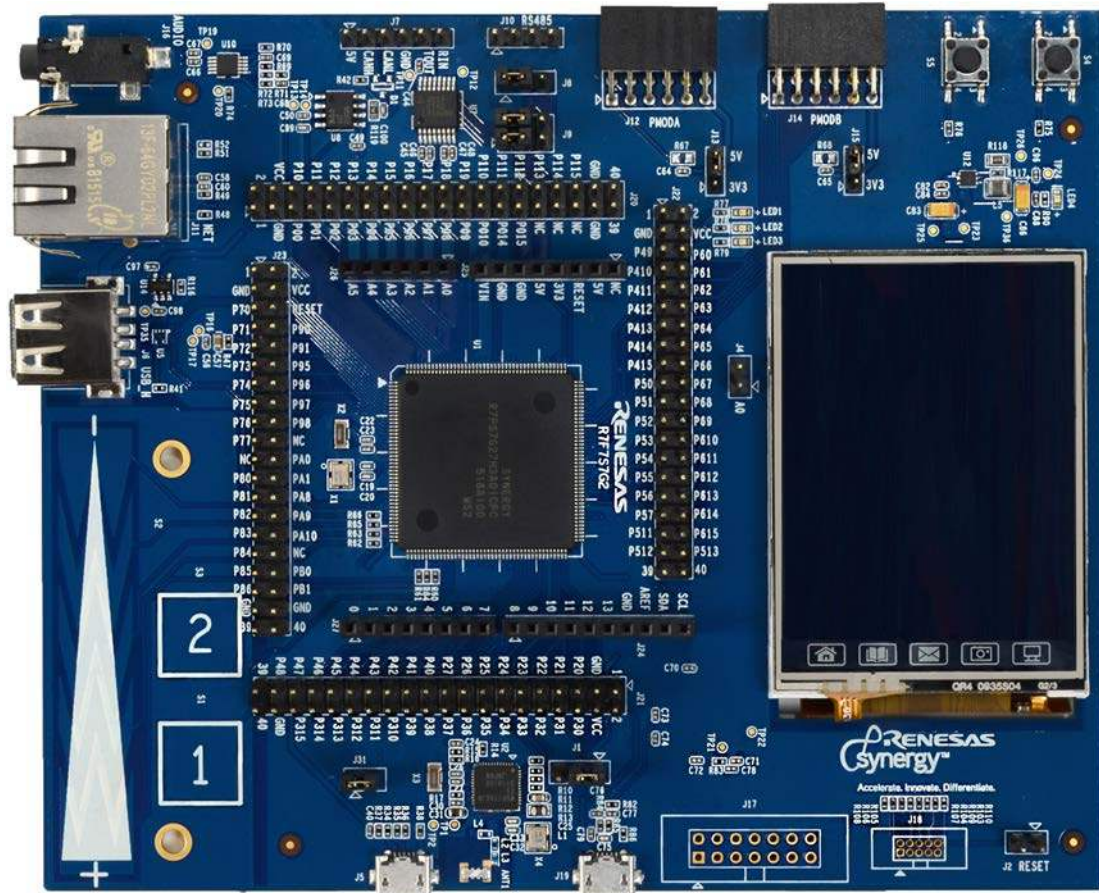

To start working with the SK-S7G2, see the Quick Start Guide included in the kit.

### 3. Power Supply Requirements

#### 3.1 Power supply

Power is supplied to the SK-S7G2 through the debug USB connector (J19). The SK-S7G2 requires 5V applied on this interface (USB standard). Once power is supplied, the power supply indicator LED4 will light green.

#### 3.2 Power-up behavior

When power is applied to the SK-S7G2, the power-on reset (POR) monitor of the S7G2 microcontroller resets the S7G2. The memory from which the S7G2 microcontroller starts program execution after reset depends on jumper J1. If J1 is in position 1-2 (default), the S7G2 starts execution from internal flash (ROM). If J1 is in position 2-3, the S7G2 starts execution in USB program mode, which enables you to load a program directly to the internal microcontroller flash through the USB device interface.

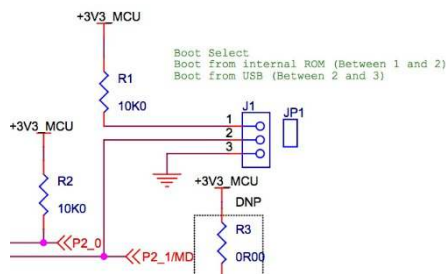

Figure 3: CPU startup mode

The microcontroller can be forced to reset by the J2 jumper even while the SK-S7G2 is powered.

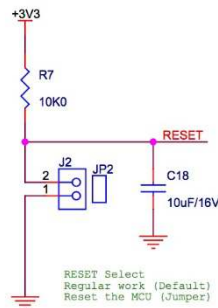

Figure 4: CPU reset control

#### 3.3 Microcontroller current

Power consumption of the S7G2 microcontroller can be measured for the digital power supply of the microcontroller by removing the J31 jumper and measuring the current draw across it.

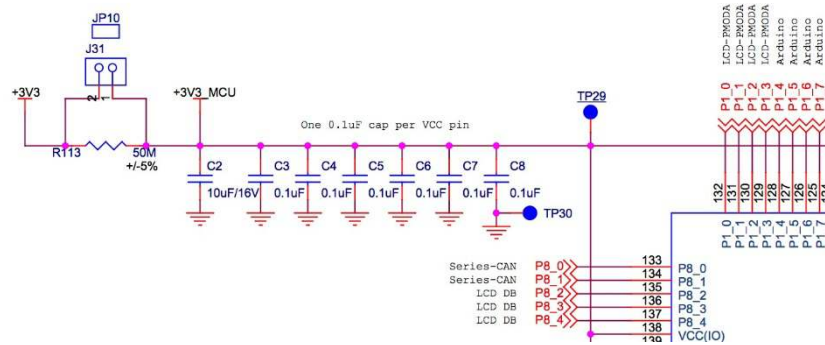

Figure 5: Measuring digital current consumption on S7G2 microcontroller

Power consumption for the analog supply of the S7G2 microcontroller requires removing resistor R114 and measuring current across it.

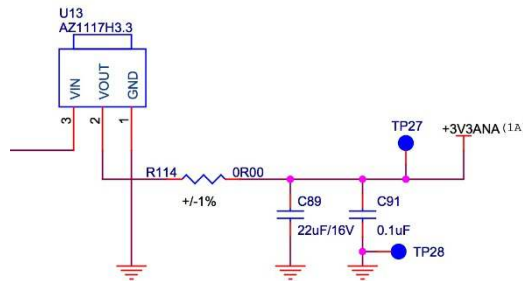

Figure 6: Measuring analog current consumption on S7G2 microcontroller



## 4. Board Components

### 4.1 J-Link On-Board debugger

The SK-S7G2 features a SEGGER J-Link On-Board debugger, accessible through the J19 USB connector. Alternatively, the onboard debugger can be bypassed by removing resistors R107, R108, R109, and R110. Once removed, JTAG/SWD debugging can then be done through the J18 header.

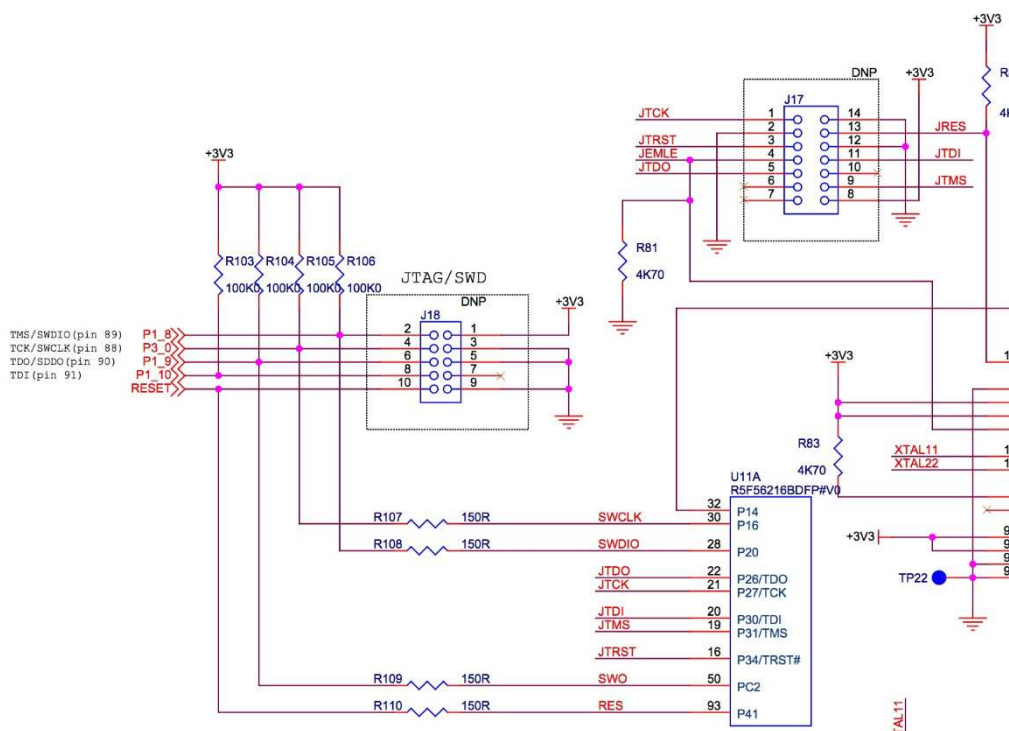

Figure 7: On/off-board JTAG debugging

### 4.2 LCD

The SK-S7G2 contains a 2.4-in. LCD panel with touch screen interface. The LCD is connected directly to the LCD interface of the S7G2 microcontroller. The LCD panel is a HaoRan HT024K5QV50T, which uses an Ilitek ILI9341V driver IC. The mode of operation of the Ilitek driver is selected with R19, R20, R22, R23, R26, R27, R28 and R29; the default mode of operation is the 4-wire, 8-bit serial interface.

NOTE:  
 [IM0,IM1,IM2,IM3]=[0,1,1,1],set the LCD mode to 4-wire 9-bit data serial interface.  
 Please refer to ILI9341V's datasheet for more informations.

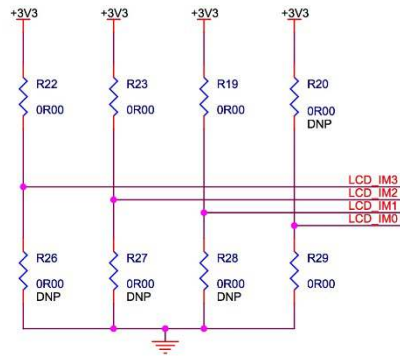

Figure 8: LCD interface mode selection

Touch-screen sensing is through a Semtech SX8656 resistive touch-screen controller, connected to the S7G2 microcontroller through an IIC bus.

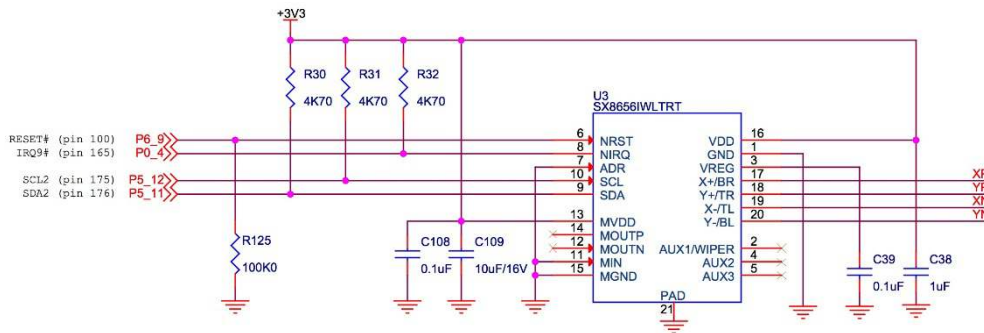

Figure 9: Touch-screen controller

### 4.3 Ethernet

The SK-S7G2 includes a Micrel KSZ8081 10/100 Ethernet physical interface. Ethernet connection is through the RJ-45 standard connector J11.

### 4.4 Pmod Compatible interfaces

The SK-S7G2 includes two standard Pmod™ Compatible interfaces. PMODA, available on the J12 connector, exposes an SPI interface, three GPIO lines, and an interrupt line to the S7G2 microcontroller.

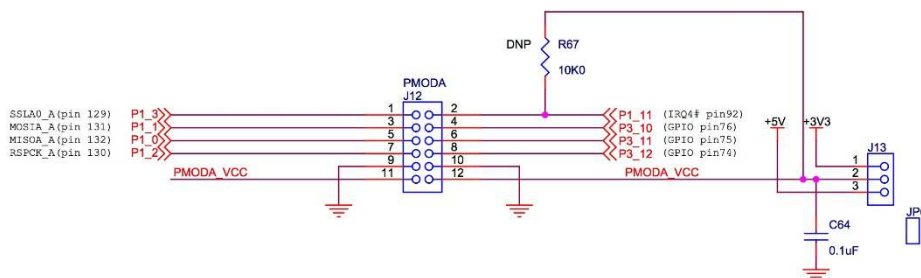

Figure 10: PMODA interface

PMODB, available on the J14 connector, exposes a UART, three GPIO lines, and an interrupt line to the S7G2 microcontroller.

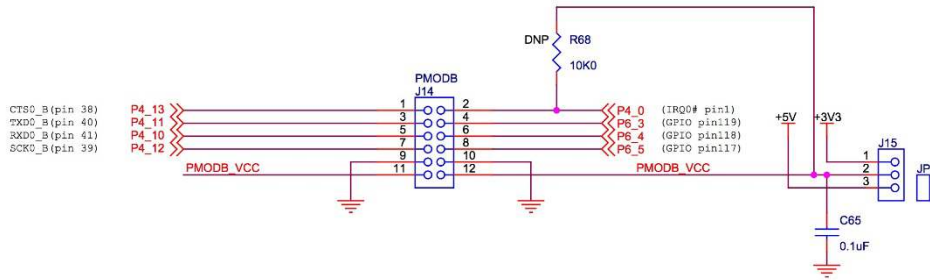

Figure 11: PMODB interface

Both PMOD interfaces can output either 5V or 3.3V, depending on the position of the J13 and J15 jumpers.

### 4.5 CAN, RS-232/485

The SK-S7G2 includes a UART interface (either RS-232 or RS-485) and a CAN interface. The CAN interface is exposed on connector J7, while the UART interface is available on connector J7 in RS-232 format (jumper J9 has to be in positions 1-3 and 2-4), or in raw TTL format in connector J10 (jumper J9 has to be in positions 3-5 and 4-6 to be connected to an external RS-485 converter).

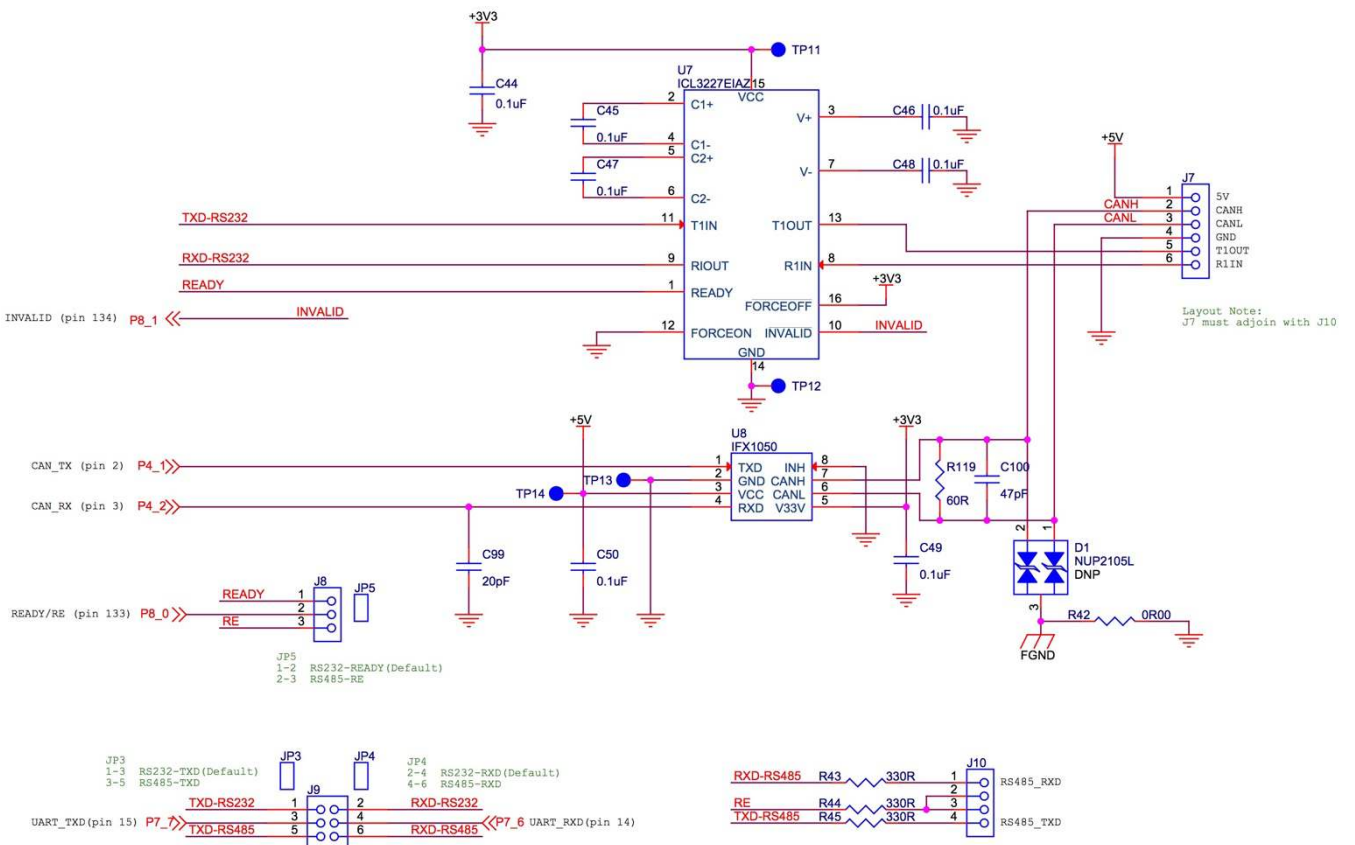

Figure 12: RS-232/485 and CAN interfaces

### 4.6 USB Device port

The SK-S7G2 is equipped with a USB Full-Speed (12-Mbps) Device port on J5. The SK-S7G2 cannot be powered through this interface (power still needs to be applied through the USB device port J19), but connection to this port can be detected since the power pin of this port is connected to a microcontroller GPIO.

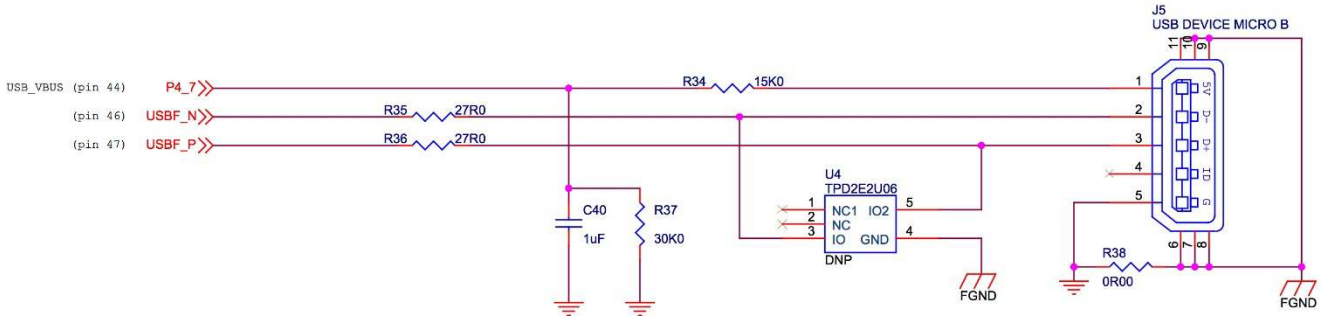

Figure 13: USB Device port

### 4.7 USB Host port

The SK-S7G2 is equipped with a USB High-Speed (480-Mbps) Host port on J6. This host port can source current to devices connected to it, and over-consumption conditions on devices can be detected.

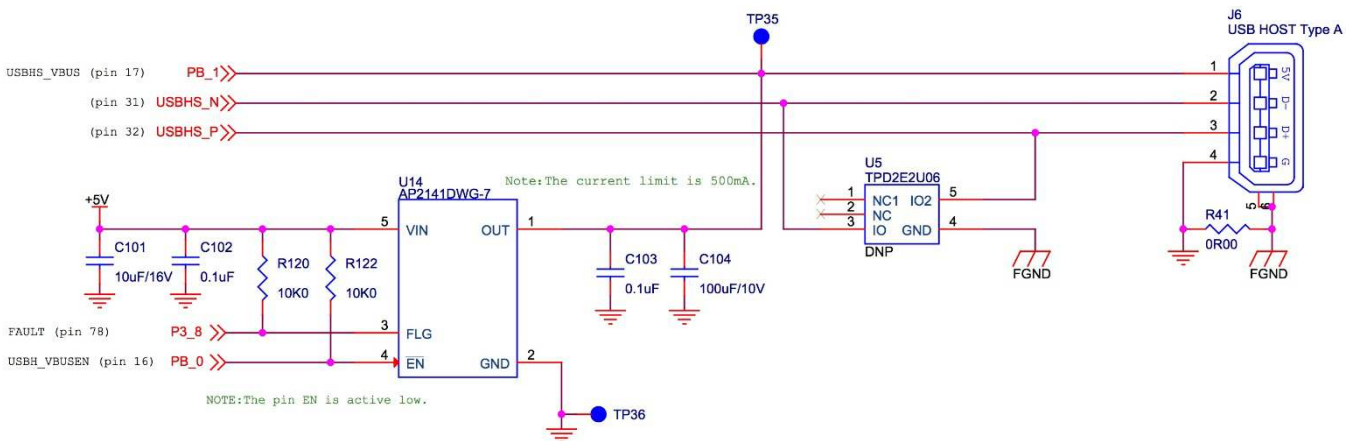

Figure 14: USB Host port

### 4.8 Capacitive touch interface

The SK-S7G2 kit contains two capacitive buttons (S1 and S3) and one slider (S2) connected to the capacitive touch-sensing unit (CTSUS) of the S7G2 microcontroller.

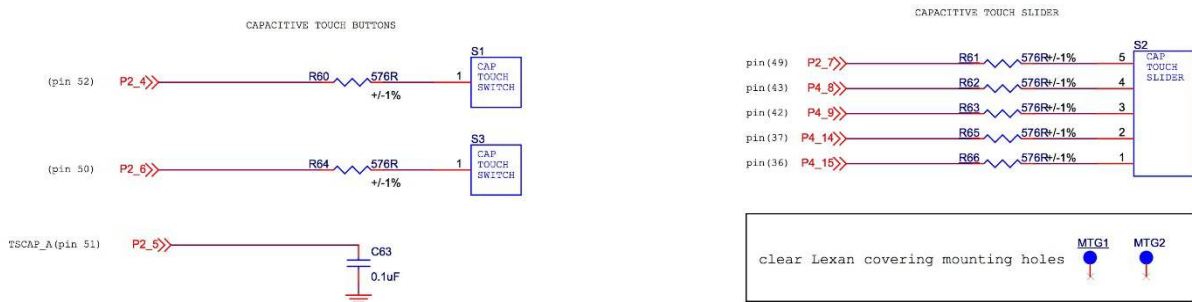

Figure 15: Capacitive touch buttons and slider

### 4.9 Audio

The SK-S7G2 contains an amplified mono audio output on a standard 3.5mm audio jack J16. The audio is generated with the S7G2 D/A converter on output DA0, and the amplification gain can be changed by modifying resistor pairs R70/R71 and R73/R72.

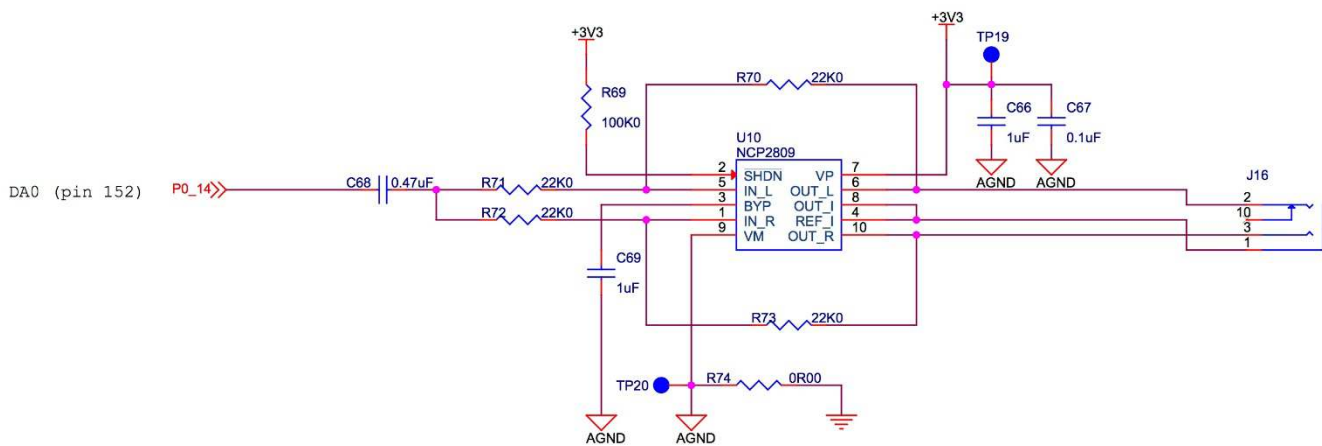

Figure 16: Audio output

### 4.10 User buttons and LEDs

The SK-S7G2 includes two user buttons directly wired to interrupt pins of the S7G2 microcontroller, as well as three generic user LEDs connected to microcontroller GPIO pins.



Figure 17: User buttons and LEDs

### 4.11 QSPI flash

The SK-S7G2 includes one 64Mb (8MB) QSPI flash connected to the QSPI interface of the microcontroller.

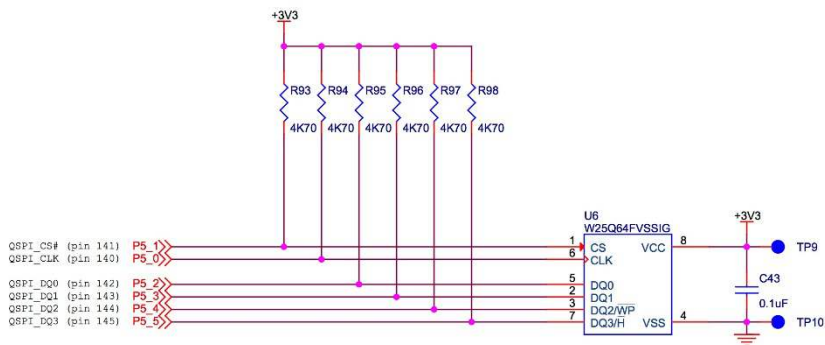

Figure 18: QSPI flash

### 4.12 Arduino Shield interface

The SK-S7G2 includes one Arduino Shield compatible interface, so that Arduino Shield boards can expand the SK-S7G2 functionality. The Arduino Shield interface is implemented with the J24, J25, J26, and J27 connectors.

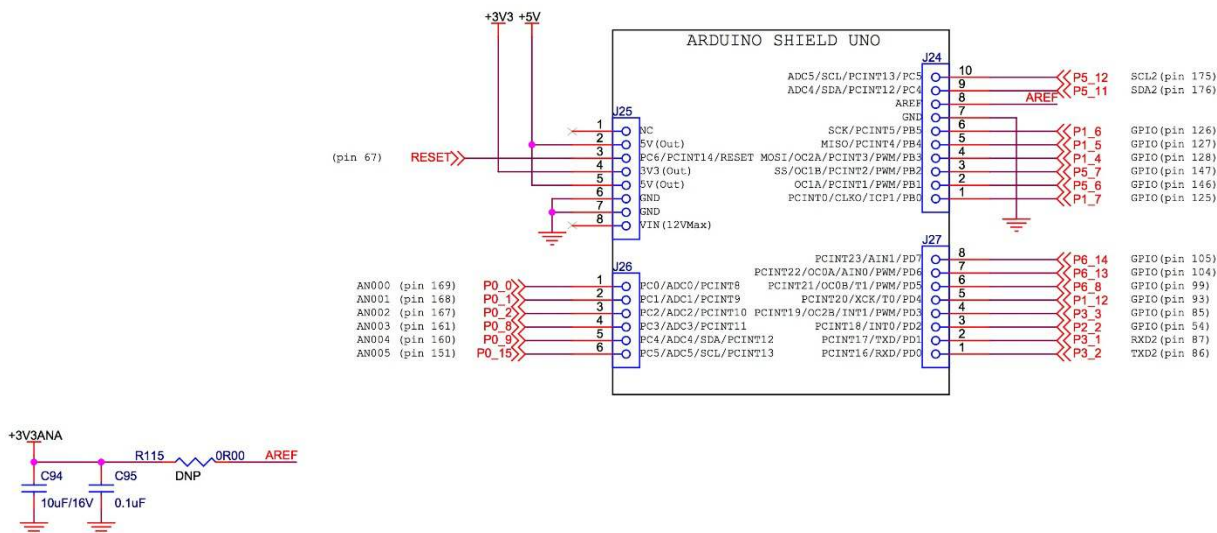

Figure 19: Arduino Shield interface

### 4.13 Breakout headers

All of the S7G2 microcontroller I/O pins are accessible through four double row 2.54-mm (0.1-in.) pitch breakout headers (J20 through J23).

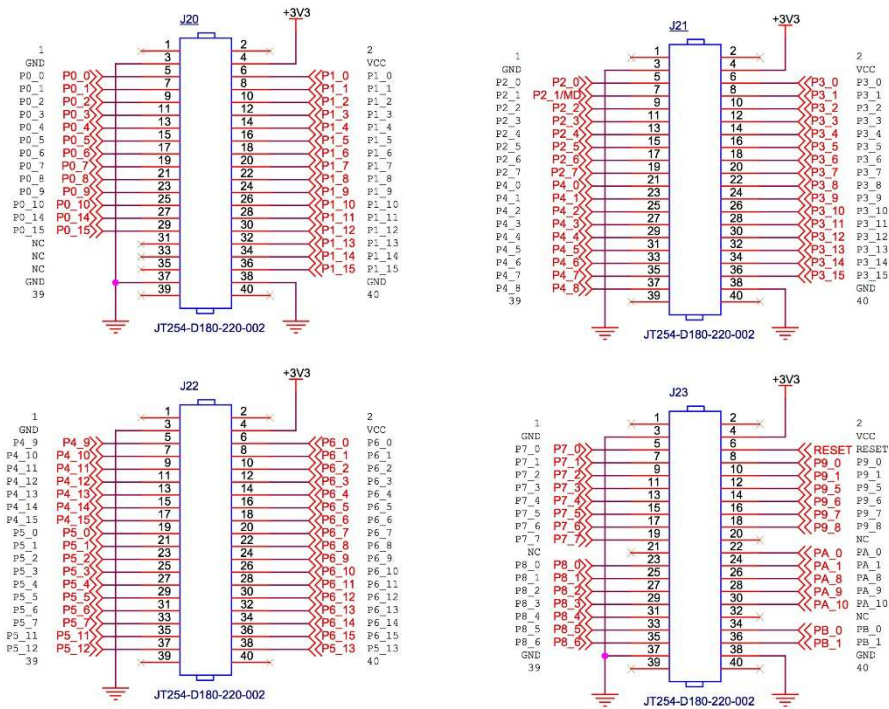

Figure 20: S7G2 microcontroller breakout headers

# 5. Board Layout

The SK-S7G2 board measures 145mm x 120mm. Figure 21 shows the location of all the relevant board components described in the prior section.

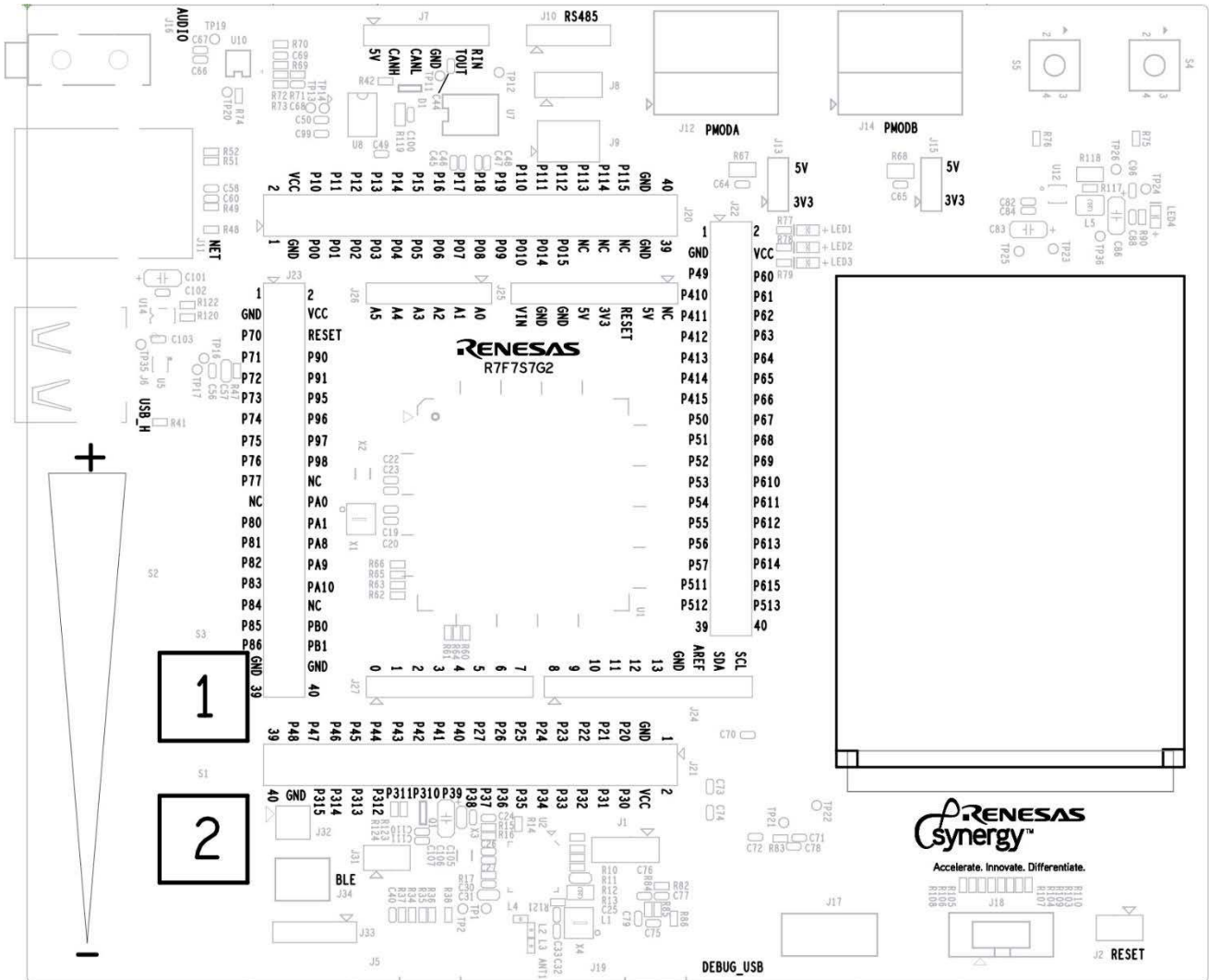

Figure 21: SK-S7G2 component placement



## 6. Configuration

The SK-S7G2 kit has several configuration options set by jumpers. Table 1 lists the different jumpers and their positions.

**Table 1: SK-S7G2 configuration jumpers**

Jumper	Function
J1	S7G2 boot selection. If J1 is in position 1-2 (default), the MCU boots in normal mode (from its ROM). If J1 is set on the 2-3 position, the MCU boots in USB programming mode, which allows programming the MCU flash through the USB port.
J2	S7G2 MCU reset. If J2 is set, MCU is reset. If J2 is open, MCU reset is released.
J8	RS-232 transmit ready/RS-485 receive enable selector jumper. If J8 is in position 1-2 (default), the RS-232 driver's transmit ready signal (which indicates that the transmit voltages are appropriate) is connected to an MCU GPIO signal. If J8 is in position 2-3, the (external) RS-485 driver's receive enable is connected to the same MCU GPIO signal.
J9	RS-232/485 mode selection jumper. If J9 is in position 1-3 & 2-4 (default), the MCU's SCI3 port is connected to the RS-232 driver (which is exposed on the J7 port). If J9 is in the 3-5 & 4-6 position, the MCU's SCI3 port is connected to the RS-485 port (J10) for an off-board driver.
J13	PMODA 3.3V/5V output selection. If J13 is set on the position labeled "5V", then 5V are provided in the PMODA connector. If J13 is set on the "3V3" labeled position, then 3.3V are provided in the PMODA interface.
J15	PMODB 3.3V/5V output selection. If J15 is set on the position labeled "5V", then 5V are provided in the PMODB connector. If J15 is set on the "3V3" labeled position, then 3.3V are provided in the PMODB interface.
J31	Power measurement jumper for S7G2. If J31 is installed, (digital) MCU current goes through the jumper. If J31 is removed, the (digital) MCU current consumption will go through an ammeter connected across pins 1 and 2 of J31.

### 6.1 RS-232 transceiver configuration

The SK-S7G2 exposes the S7G2 MCU's SCI (Serial Communication Interface) port 3 through three different electrical interfaces: RS-232, (external) RS-485, and the MCU breakout headers. Table 2 summarizes the configuration alternatives for this port.

**Table 2: Configuration options for RS-232/485 port**

Option	J8	J9
RS-232 on J7	1-2	1-3 & 2-4
RS-485 on J10 (external converter)	2-3	3-5 & 4-6
TTL interface on MCU breakout headers J20-J23	removed	removed

## 7. Connectivity

The following sections describe in detail the interfaces available on the SK-S7G2, detailing the MCU resources utilized in each.

### 7.1 USB Host port

The SK-S7G2 includes one USB Host/High-Speed port (J6). This port supplies current to devices connected to it through a current limited power switch (U14). The power output can be monitored through an S7G2 microcontroller GPIO pin and enabled through another GPIO pin. Table 3 shows the S7G2 functions used for the USB Host port.

**Table 3: USB host port functions**

S7G2 Pin	Function name
USBHS_DM	USBHS_N
USBHS_DP	USBHS_P
PB01	USBHS_VBUS (monitor)
PB00	USBH_VBUSEN
P308	FAULT (monitor)

### 7.2 USB Device port

The SK-S7G2 includes one USB Device/Full-Speed port (J5). Detection of USB connection can be done by monitoring the status of the power pin of the USB device connector through its connection to a GPIO pin on the S7G2 microcontroller. Table 4 shows the S7G2 functions used for the USB device port.

**Note:** Only connect a host to this device port when the board is powered.

**Table 4: USB device port functions**

S7G2 Pin	Function name
USB_DM	USBF_N
UDB_DP	USBF_P
P407	USB_VBUS (monitor)

### 7.3 Ethernet

The SK-S7G2 includes an RJ45 Ethernet connector to the on-board Ethernet PHY. Table 5 shows the pins of the S7G2 microcontroller used on the SK-S7G2 when connected as a RMI interface to the PHY. In addition, interrupt IRQ14 is connected to the Ethernet PHY.

The Ethernet PHY is clocked by its own oscillator based on a 25.000 MHz crystal (X5).

Since the Ethernet connector (J11) is connected to the S7G2 microcontroller through other components, only the functions used by the Ethernet module on the S7G2 are shown in Table 5.

**Table 5: Ethernet functions**

S7G2 Pin	Function name
P010	ETH_IRQ14#
P806	ETH_RESET#
P403	ETH_MDC
P404	ETH_MDIO
P705	ETH_CRS_DV
P405	ETH_TXD_EN
P700	ETH_TDX0
P406	ETH_TXD1
P702	ETH_RXD0
P703	ETH_RXD1
P704	ETH_RX_ER
P701	ETH (Reference Clock)

## 7.4 LCD

The SK-S7G2 includes a 240x320 QVGA LCD panel with touch-screen interface. This display is connected directly to the S7G2's display port, and through a touchscreen controller IC to the display's touch-screen interface. Table 6 and Table 7 list the functions used by the LCD display and touch-screen controller on the S7G2.

**Table 6: LCD functions (J3)**

S7G2 Pin	Function name
P610	LCD_RESET
P314	LCD_VSYNC
P313	LCD_HSYNC
P900	LCD_CLK_B
P315	LCD_Data_Enable
P901	LCD_D15
P908	LCD_D14
P907	LCD_D13
P906	LCD_D12
P905	LCD_D11
P615	LCD_D10
PA08	LCD_D9
PA09	LCD_D8
PA10	LCD_D7
PA01	LCD_D6
PA00	LCD_D5
P607	LCD_D4
P606	LCD_D3
P802	LCD_D2
P803	LCD_D1
P804	LCD_D0
P103	LCD_CS
P102	LCD_SCK
P115	LCD_WR
P114	LCD_RD
P101	LCD_MOSI
P100	LCD_MISO

**Table 7: LCD touchscreen functions**

S7G2 Pin	Function name
P609	RESET#
P004	IRQ9#
P512	SCL2
P511	SDA2

## 7.5 Pmod Compatible ports

The SK-S7G2 includes two Pmod Compatible ports, PMODA (J12), and PMODB (J14). Both can output either 3.3-V or 5-V supply, configurable by jumpers. Table 8 and Table 9 show the S7G2 functions used for these ports.

**Table 8: PMODA port functions**

S7G2 Pin	Function name
P103	SSLA0_A
P101	MOSIA_A
P100	MISOA_A
P102	RSPCK_A
P111	IRQ4#
P310	GPIO (PMOD pin 4)
P311	GPIO (PMOD pin 6)
P312	GPIO (PMOD pin 8)

**Table 9: PMODB port functions**

S7G2 Pin	Function name
P413	CTS0_B
P411	TXD0_B
P410	RXD0_B
P412	SCK0_B
P400	IRQ0#
P603	GPIO (PMOD pin 4)
P604	GPIO (PMOD pin 6)
P605	GPIO (PMOD pin 8)

## 7.6 JTAG/SWD

The SK-S7G2 provides several alternatives for JTAG emulation/debugging. An onboard SEGGER J-Link JTAG debugger is accessible through the debugging/power USB port (J19). There is also direct access to the S7G2 microcontroller JTAG/SWD port through connector J18. To enable the direct access connector, the resistors that connect the onboard J-Link debugger with the MCU (R107, R108, R109, and R110) must be removed. Table 10 shows the S7G2 functions connected to the direct access JTAG/SWD connector.

**Table 10: JTAG/SWD functions**

S7G2 Pin	Function name
P108	TMS/SWDIO
P300	TCK/SWCLK
P109	TDO/SDDO
P110	TDI
RESET	RESET

## 7.7 UART & CAN

The SK-S7G2 exposes one MCU UART as an external connection, as well as a CAN interface (J7 and J10). The UART interface can be configured to operate in RS-232 mode or in RS-485 (with an external driver IC) depending on the position of jumpers J8 and J9. Table 11 and Table 12 show the S7G2 functions connected to these interfaces.

**Table 11: UART interface functions**

S7G2 Pin	Function name
P706	UART_RXD
P707	UART_TXD
P801	INVALID
P800	READY (RS-232) or RE (RS-485)

**Table 12: CAN interface functions**

S7G2 Pin	Function name
P401	CAN_TX
P402	CAN_RX

## 8. Pin Connections

Table 13 shows the connection of S7G2 pins to SK-S7G2 functions.

**Table 13: Pin connections**

S7G2 Pin	Peripheral	Signal	SK-S7G2 connector
P000	Arduino Shield	AN000	J26 (1)
P001	Arduino Shield	AN001	J26 (2)
P002	Arduino Shield	AN002	J26 (3)
P004	LCD (Touchscreen)	IRQ9#	n/a
P005	User Button	IRQ10#	S5
P006	User Button	IRQ11#	S4
P007	Arduino Shield	n/a	J24 (1)
P008	Arduino Shield	AN003	J26 (4)
P009	Arduino Shield	AN004	J26 (5)
P010	Ethernet	ETH_IRQ14#	n/a
P014	Audio	DA0	n/a
P015	Arduino Shield	AN005	J26 (6)
P100	LCD / PMODA	LCD_MISO / MISOA_A	J3 (18) / J12 (5)
P101	LCD / PMODA	LCD_MOSI / MOSIA_A	J3 (17) / J12 (3)
P102	LCD / PMODA	LCD_SCK / RSPCK_A	J3 (14) / J12 (7)
P103	LCD / PMODA	LCD_CS / SSLA0_A	J3 (13) / J12 (1)
P104	Arduino Shield	n/a	J24 (4)
P105	Arduino Shield	n/a	J24 (5)
P106	Arduino Shield	n/a	J24 (6)
P108	JTAG	TMS/SWDIO	J18 (2)
P109	JTAG	TDO/SDDO	J18 (6)
P110	JTAG	TDI	J18 (8)
P111	PMODA	IRQ4#	J12 (2)
P112	Arduino Shield	n/a	J27 (5)
P113	Bluetooth™	BLE_PWR_EN	n/a
P202	Arduino Shield	n/a	J27 (3)
P204	Cap Touch	n/a	S1
P205	Cap Touch	n/a	S3
P206	Cap Touch	TSCAP_A	n/a
P207	Cap Touch	n/a	S2 (5)
P300	JTAG	TCK/SWCLK	J18 (4)
P301	Bluetooth / Arduino Shield	RXD2 / RXD2	n/a / J27 (2)
P302	Bluetooth / Arduino Shield	TXD2 / TXD2	n/a / J27 (1)
P303	Arduino Shield	n/a	J27 (4)
P304	Bluetooth	RXD6_A	n/a
P305	Bluetooth	TXD6_A	n/a
P306	Bluetooth	SCK6_A	n/a
P308	USB Host	FAULT	n/a
P309	Bluetooth	BLE_RESET	n/a

S7G2 Pin	Peripheral	Signal	SK-S7G2 connector
P310	PMODA	n/a	J12 (4)
P311	PMODA	n/a	J12 (6)
P312	PMODA	n/a	J12 (8)
P313	LCD	LCD_HSYNC	J3 (40)
P314	LCD	LCD_VSYNC	J3 (41)
P315	LCD	LCD_Data_Enable	J3 (38)
P400	PMODB	IRQ0#	J14 (2)
P401	CAN	CAN_TX	
P402	CAN	CAN_RX	
P403	Ethernet	ETH_MDC	
P404	Ethernet	ETH_MDIO	
P405	Ethernet	ETH_TXD_EN	
P406	Ethernet	ETH_TXD1	
P407	USB Device	USB_VBUS	J5 (1)
P408	Cap Touch	n/a	S2 (4)
P409	Cap Touch	n/a	S2 (3)
P410	PMODB	RXD0_B	J14 (5)
P411	PMODB	TXD0_B	J14 (3)
P412	PMODB	SCK0_B	J14 (7)
P413	PMODB	CTS0_B	J14 (1)
P414	Cap Touch	n/a	S2 (2)
P415	Cap Touch	n/a	S2 (1)
P500	QSPI Flash	QSPI_CLK	n/a
P501	QSPI Flash	QSPI_CS#	n/a
P502	QSPI Flash	QSPI_DQ0	n/a
P503	QSPI Flash	QSPI_DQ1	n/a
P504	QSPI Flash	QSPI_DQ2	n/a
P505	QSPI Flash	QSPI_DQ3	n/a
P506	Arduino Shield	n/a	J24 (2)
P507	Arduino Shield	n/a	J24 (3)
P511	LCD (Touchscreen) / Arduino Shield	SDA2 / SDA2	n/a / J24 (9)
P512	LCD (Touchscreen) / Arduino Shield	SCL2 / SCL2	n/a / J24 (10)
P600	User LED	n/a	LED1
P601	User LED	n/a	LED2
P602	User LED	n/a	LED3
P603	PMODB	n/a	J14 (4)
P604	PMODB	n/a	J14 (6)
P605	PMODB	n/a	J14 (8)
P606	LCD	LCD_D3	J3 (24)
P607	LCD	LCD_D4	J3 (25)



S7G2 Pin	Peripheral	Signal	SK-S7G2 connector
P608	Arduino Shield	n/a	J27 (6)
P609	LCD (Touchscreen)	RESET#	n/a
P613	Arduino Shield	n/a	J27 (7)
P614	Arduino Shield	n/a	J27 (8)
P615	LCD	LCD_D10	J3 (31)
P700	Ethernet	ETH_TXD0	n/a
P701	Ethernet	ETH	n/a
P702	Ethernet	ETH_RXD0	n/a
P703	Ethernet	ETH_RXD1	n/a
P704	Ethernet	ETH_RX_ER	n/a
P705	Ethernet	ETH_CRSDV	n/a
P706	RS-232	UART_RXD	J9 (4)
P707	RS-232	UART_TXD	J9 (3)
P800	RS-232	READY/RE	J8 (2)
P801	RS-232	INVALID	n/a
P802	LCD	LCD_D2	J3 (23)
P803	LCD	LCD_D1	J3 (22)
P804	LCD	LCD_D0	J3 (21)
P806	Ethernet	ETH_RESET#	n/a
P900	LCD	LCD_CLK_B	J3 (39)
P901	LCD	LCD_D15	J3 (37)
P905	LCD	LCD_D11	J3 (33)
P906	LCD	LCD_D12	J3 (34)
P907	LCD	LCD_D13	J3 (35)
P908	LCD	LCD_D14	J3 (36)
PA00	LCD	LCD_D5	J3 (26)
PA01	LCD	LCD_D6	J3 (27)
PA08	LCD	LCD_D9	J3 (30)
PA09	LCD	LCD_D8	J3 (29)
PA10	LCD	LCD_D7	J3 (28)
PB00	USB Host	USBH_VBUSEN	n/a
PB01	USB Host	USBHS_VBUS	J6 (1)
RESET	JTAG	RESET	J18 (10)
USBHS_N	USB Host	USBHS_N	J6 (2)
USBHS_P	USB Host	USBHS_P	J6 (3)
USBF_N	USB Device	USBF_N	J5 (2)
USBF_P	USB Device	USBF_P	J5 (3)

Revision History	SK-S7G2 User's Manual
------------------	-----------------------

Rev.	Date	Description	
		Page	Summary
1.00	Oct. 2015	—	First Edition issued

---

Sk-S7G2 User's Manual

Publication Date: Rev.1.00 Oct. 2015

Published by: Renesas Electronics Corporation

---

**SALES OFFICES****Renesas Electronics Corporation**<http://www.renesas.com>Refer to "<http://www.renesas.com/>" for the latest and detailed information.**Renesas Electronics America Inc.**2801 Scott Boulevard Santa Clara, CA 95050-2549, U.S.A.  
Tel: +1-408-588-6000, Fax: +1-408-588-6130**Renesas Electronics Canada Limited**9251 Yonge Street, Suite 8309 Richmond Hill, Ontario Canada L4C 9T3  
Tel: +1-905-237-2004**Renesas Electronics Europe Limited**Dukes Meadow, Millboard Road, Bourne End, Buckinghamshire, SL8 5FH, U.K.  
Tel: +44-1628-585-100, Fax: +44-1628-585-900**Renesas Electronics Europe GmbH**Arcadiastrasse 10, 40472 Düsseldorf, Germany  
Tel: +49-211-6503-0, Fax: +49-211-6503-1327**Renesas Electronics (China) Co., Ltd.**Room 1709, Quantum Plaza, No.27 ZhiChunLu Haidian District, Beijing 100191, P.R.China  
Tel: +86-10-8235-1155, Fax: +86-10-8235-7679**Renesas Electronics (Shanghai) Co., Ltd.**Unit 301, Tower A, Central Towers, 555 Langao Road, Putuo District, Shanghai, P. R. China 200333  
Tel: +86-21-2226-0888, Fax: +86-21-2226-0999**Renesas Electronics Hong Kong Limited**Unit 1601-1611, 16/F., Tower 2, Grand Century Place, 193 Prince Edward Road West, Mongkok, Kowloon, Hong Kong  
Tel: +852-2265-6688, Fax: +852 2886-9022**Renesas Electronics Taiwan Co., Ltd.**13F, No. 363, Fu Shing North Road, Taipei 10543, Taiwan  
Tel: +886-2-8175-9600, Fax: +886 2-8175-9670**Renesas Electronics Singapore Pte. Ltd.**80 Bendemeer Road, Unit #06-02 Hyflux Innovation Centre, Singapore 339949  
Tel: +65-6213-0200, Fax: +65-6213-0300**Renesas Electronics Malaysia Sdn.Bhd.**Unit 1207, Block B, Menara Amcorp, Amcorp Trade Centre, No. 18, Jln Persiaran Barat, 46050 Petaling Jaya, Selangor Darul Ehsan, Malaysia  
Tel: +60-3-7955-9390, Fax: +60-3-7955-9510**Renesas Electronics India Pvt. Ltd.**No.777C, 100 Feet Road, HALII Stage, Indiranagar, Bangalore, India  
Tel: +91-80-67208700, Fax: +91-80-67208777**Renesas Electronics Korea Co., Ltd.**12F., 234 Teheran-ro, Gangnam-Gu, Seoul, 135-080, Korea  
Tel: +82-2-558-3737, Fax: +82-2-558-5141

# Renesas Synergy™ SK-S7G2

## User's Manual

