

PART NUMBER	SSI-LXR3612GD	REV.	D
DATE	E.C.N. NUMBER AND REVISION COMMENTS		REV.
09.19.94	UPDATED SAFE OPER. SPECS AND NOTES.		A
05.16.95	ADDED BUSHING TO DRAWING.		B
01.04.02	E.C.N. #10BRDR. & REDRAWN IN 3D.		C
7.14.11	E.C.N. #10BRDR. & REDRAWN.		D

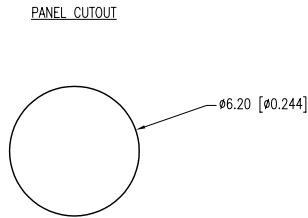
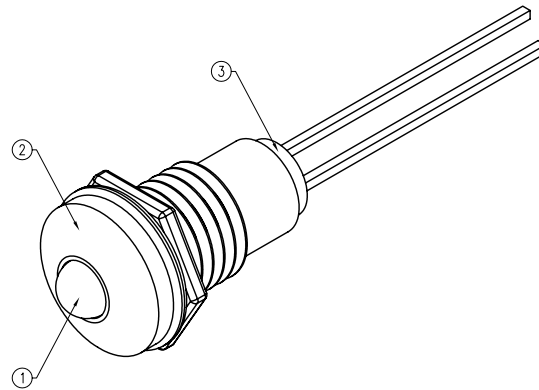
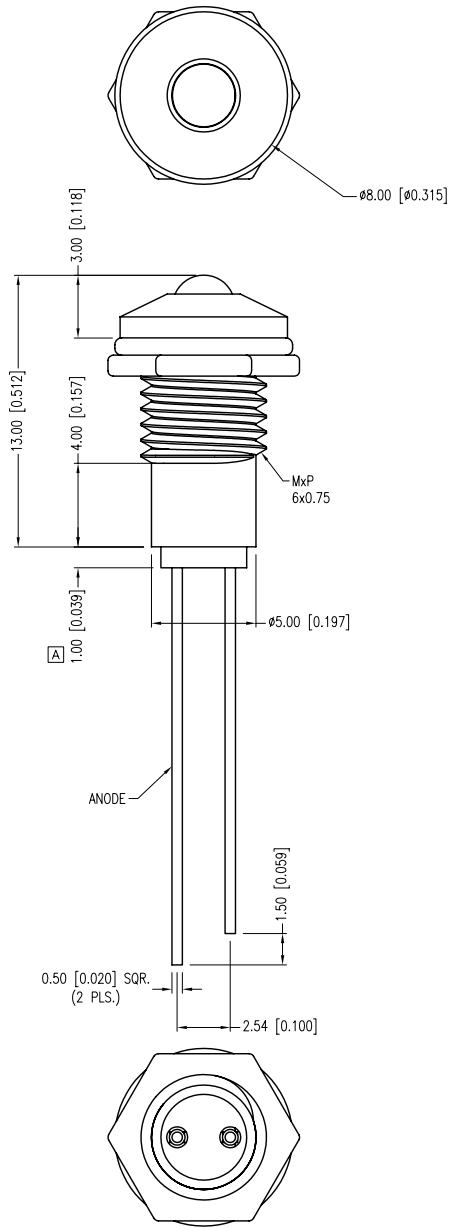

ELECTRO-OPTICAL CHARACTERISTICS $T_a=25^\circ\text{C}$			$I_f=20\text{mA}$		
PARAMETER	MIN	TYP	MAX	UNITS	UNITS
PEAK WAVELENGTH		565		nm	
FORWARD VOLTAGE		2.2	2.6	Vf	
REVERSE VOLTAGE	5.0			Vr	$I_r=100\mu\text{A}$
AXIAL INTENSITY	14	30		mcd	$I_f=10\text{mA}$
VIEWING ANGLE		60		2x theta	
EMITTED COLOR:	GREEN				
EPOXY LENS FINISH:	GREEN DIFFUSED				

LIMITS OF SAFE OPERATION AT 25°C		
PARAMETER	MAX	UNITS
PEAK FORWARD CURRENT*	150	mA
STEADY CURRENT	25	mA
POWER DISSIPATION	105	mW
DERATE FROM 25°C	-1.6	mW/°C
OPERATING TEMP.	-40 TO +85	°C
STORAGE TEMP.	-40 TO +85	°C
SOLDERING TEMP.	+260	°C
2.0mm FROM BODY	3	SEC. MAX.

\*  $t < 10\mu\text{s}$

- [A] NOTES:
- SSL-LX3054GD, GREEN LED.
  - SSI-LXR3612, CHROME HOUSING.
  - SSH-LXH1612BSG, BUSHING, INSERT AND CRIMP.

\*UNLESS OTHERWISE SPECIFIED TOLERANCES PER DECIMAL PRECISION ARE: X=±1 (±0.039), XX=±0.5 (±0.020), XXX=±0.25 (±0.010), XXXX=±0.127 (±0.005). LEAD SIZE=±0.05 (±0.002), LEAD LENGTH=±0.75 (±0.030). MIN= <sup>+DECIMAL PRECISION</sup> <sub>-0.00</sub> MAX= <sup>+0.00</sup> <sub>-DECIMAL PRECISION</sub> UNCONTROLLED DOCUMENT

**LUMEX**  
Creating LED and LCD Solutions Together™

290 E. HELEN ROAD  
PALATINE, IL 60067-6976  
PHONE: +1.847.359.2790  
FAX: +1.847.359.6538  
WEB: WWW.LUMEX.COM

T-3mm (T-1) 565nm GREEN PANEL INDICATOR, GREEN DIFFUSED LENS.

\*\*THE SPECIFICATIONS MAY CHANGE AT ANY TIME WITHOUT NOTICE DUE TO NEW MATERIALS OR PRODUCT IMPROVEMENT.\*\*

CONFIDENTIAL INFORMATION  
THE INFORMATION CONTAINED IN THIS DOCUMENT IS THE PROPERTY OF LUMEX INC. EXCEPT AS SPECIFICALLY AUTHORIZED IN WRITING BY LUMEX INC., THE HOLDER OF THIS DOCUMENT SHALL KEEP ALL INFORMATION CONTAINED HEREIN CONFIDENTIAL AND SHALL PROTECT SAME IN WHOLE OR IN PART FROM DISCLOSURE AND DISSEMINATION TO ALL THIRD PARTIES.

DATE:	07.14.11	DRAWN BY:	AB
PAGE:	1 OF 1	CHKD BY:	KF
SCALE:	NTS	APRVD BY:	SS
UNIT:	mm [INCH]		Ⓟ