

200 mA 36 V Input Ultra Low Supply Current VR Evaluation Board

No. EEV-332-N033B-200707

R1524N033B-EV is the evaluation board for R1524 which has the below features, benefits and specifications.

OUTLINE

The R1524N is an ultra-low supply current voltage regulator featuring 200 mA output current and 36 V input voltage. This device consists of an Output Short-circuit Protection Circuit, an Over-current Protection Circuit, and a Thermal Shutdown Circuit in addition to the basic regulator circuits. The operating temperature range is from -40°C to 105°C , and the maximum input voltage is 36 V. All these features allow the R1524N to become an ideal power source of electric home appliances.

The output voltages are internally fixed. The output voltage accuracy is $\pm 0.6\%$.

FEATURES

- Input Voltage Range (Maximum Rating) 3.5 V to 36 V (50 V)
- Operating Temperature Range -40°C to 105°C
- Supply Current Typ. 2.2 μA
- Standby Current Typ. 0.1 μA
- Dropout Voltage Typ. 0.8 V ($I_{\text{OUT}} = 200 \text{ mA}$)
- Output Voltage 3.3 V
- Output Voltage Accuracy $\pm 0.6\%$ ($T_{\text{a}} = 25^{\circ}\text{C}$)
- Output Voltage Temperature-Drift Coefficient Typ. $\pm 60 \text{ ppm}/^{\circ}\text{C}$
- Line Regulation Typ. 0.01%/V ($V_{\text{SET}} + 1 \text{ V} \leq V_{\text{IN}} \leq 36 \text{ V}$)
- Built-in Output Short-circuit Protection Circuit Typ. 80 mA
- Built-in Over-current Protection Circuit Typ. 350 mA
- Built-in Thermal Shutdown Circuit Thermal Shutdown Temperature: Typ. 160°C
- Ceramic capacitors are recommended
to be used with this device $C_{\text{OUT}} = 0.1 \mu\text{F}$ or more
- Packages SOT-23-5
- For more details on R1524 IC, please refer to
<https://www.nisshinbo-microdevices.co.jp/en/pdf/datasheet/r1524-ea.pdf>.

PCB LAYOUT

R1524N (Package: SOT-23-5)

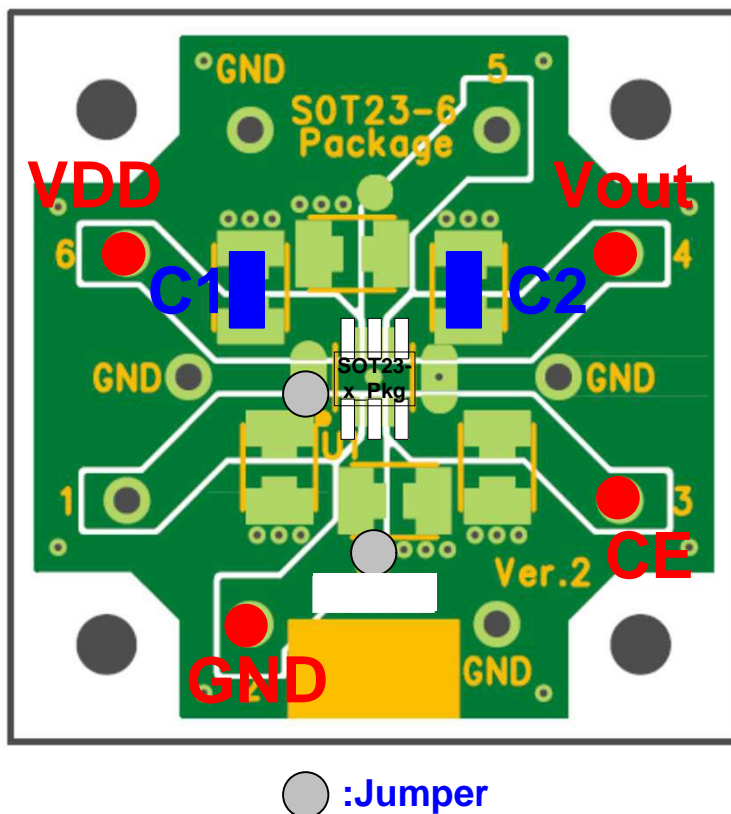

ABSOLUTE MAXIMUM RATINGS

Absolute Maximum Ratings

| Symbol | Item | Rating | Unit |
|-----------|--|--------------------------------|------|
| V_{IN} | Input Voltage | -0.3 to 50 | V |
| V_{IN} | Peak Input Voltage ⁽¹⁾ | 60 | V |
| V_{CE} | Input Voltage (CE Pin) | -0.3 to 50 | V |
| V_{OUT} | Output Voltage | -0.3 to $V_{IN} + 0.3 \leq 50$ | V |
| I_{OUT} | Output Current | 300 | mA |
| P_D | Power Dissipation ⁽²⁾ (JEDEC STD.51-7 Test Land Pattern) | SOT-23-5 660 | mW |
| T_j | Junction Temperature Range | -40 to 125 | °C |
| T_{stg} | Storage Temperature Range | -55 to 125 | °C |

ABSOLUTE MAXIMUM RATINGS

Electronic and mechanical stress momentarily exceeded absolute maximum ratings may cause permanent damage and may degrade the lifetime and safety for both device and system using the device in the field. The functional operation at or over these absolute maximum ratings are not assured.

RECOMMENDED OPERATING CONDITIONS

Recommended Operating Conditions

| Symbol | Item | Rating | Unit |
|----------|-----------------------------|------------|------|
| V_{IN} | Input Voltage | 3.5 to 36 | V |
| T_a | Operating Temperature Range | -40 to 105 | °C |

RECOMMENDED OPERATING CONDITIONS

All of electronic equipment should be designed that the mounted semiconductor devices operate within the recommended operating conditions. The semiconductor devices cannot operate normally over the recommended operating conditions, even if they are used over such conditions by momentary electronic noise or surge. And the semiconductor devices may receive serious damage when they continue to operate over the recommended operating conditions.

⁽¹⁾ Duration time: 200 ms

⁽²⁾ Refer to *DATASHEET POWER DISSIPATION* for detailed information.

PIN DESCRIPTIONS

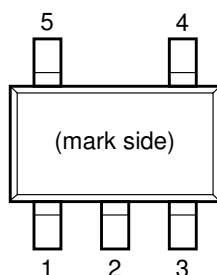

SOT-23-5 Pin Configuration

SOT-23-5 Pin Descriptions

| Pin No. | Symbol | Description |
|---------|--------------------|-------------------------------|
| 1 | GND ⁽¹⁾ | Ground Pin |
| 2 | GND ⁽²⁾ | Ground Pin |
| 3 | CE | Chip Enable Pin (Active-high) |
| 4 | V _{OUT} | Output Pin |
| 6 | V _{OUT} | Output Pin |

⁽¹⁾ The GND pin must be wired together when it is mounted on board.

THEORY OF OPERATION

TYPICAL APPLICATION

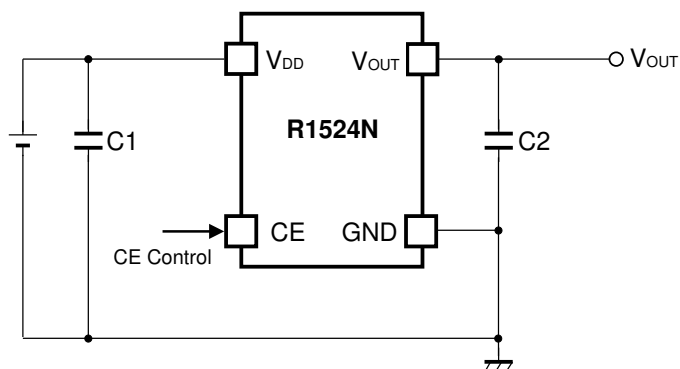

R1524N Typical Applications

Recommended External Components⁽¹⁾

| Symbol | Value |
|-------------------|-------------|
| C1 | 0.1 μ F |
| C2 ⁽²⁾ | 10 μ F |

⁽¹⁾ The bill of materials will be attached on the shipment of each purchased evaluation board.

⁽²⁾ Although C2 operates even at 0.1 μ F, C2 = 10 μ F is recommended to improve transient characteristics.

TECHNICAL NOTES

Phase Compensation

In the R1524N, phase compensation is provided to secure stable operation even when the load current is varied. For this purpose, make sure to use 0.1 μF or more of a capacitor (C2).

In case of using a tantalum type capacitor and the ESR (Equivalent Series Resistance) value of the capacitor is large, the output might be unstable. Evaluate the circuit including consideration of frequency characteristics. Connect 0.1 μF or more of a capacitor (C1) between V_{DD} and GND, and as close as possible to the pins.

PCB Layout

For SOT-23-5 package type, wire the following GND pins together: No. 1 and No. 2



1. The products and the product specifications described in this document are subject to change or discontinuation of production without notice for reasons such as improvement. Therefore, before deciding to use the products, please refer to our sales representatives for the latest information thereon.
2. The materials in this document may not be copied or otherwise reproduced in whole or in part without prior written consent of our company.
3. Please be sure to take any necessary formalities under relevant laws or regulations before exporting or otherwise taking out of your country the products or the technical information described herein.
4. The technical information described in this document shows typical characteristics of and example application circuits for the products. The release of such information is not to be construed as a warranty of or a grant of license under our company's or any third party's intellectual property rights or any other rights.
5. The products listed in this document are intended and designed for use as general electronic components in standard applications (office equipment, telecommunication equipment, measuring instruments, consumer electronic products, amusement equipment etc.). Those customers intending to use a product in an application requiring extreme quality and reliability, for example, in a highly specific application where the failure or misoperation of the product could result in human injury or death (aircraft, spacevehicle, nuclear reactor control system, traffic control system, automotive and transportation equipment, combustion equipment, safety devices, life support system etc.) should first contact us.
6. We are making our continuous effort to improve the quality and reliability of our products, but semiconductor products are likely to fail with certain probability. In order to prevent any injury to persons or damages to property resulting from such failure, customers should be careful enough to incorporate safety measures in their design, such as redundancy feature, fire containment feature and fail-safe feature. We do not assume any liability or responsibility for any loss or damage arising from misuse or inappropriate use of the products.
7. Anti-radiation design is not implemented in the products described in this document.
8. The X-ray exposure can influence functions and characteristics of the products. Confirm the product functions and characteristics in the evaluation stage.
9. WLCSP products should be used in light shielded environments. The light exposure can influence functions and characteristics of the products under operation or storage.
10. There can be variation in the marking when different AOI (Automated Optical Inspection) equipment is used. In the case of recognizing the marking characteristic with AOI, please contact our sales or our distributor before attempting to use AOI.
11. Please contact our sales representatives should you have any questions or comments concerning the products or the technical information.



Nisshinbo Micro Devices Inc.

Official website

<https://www.nisshinbo-microdevices.co.jp/en/>

Purchase information

<https://www.nisshinbo-microdevices.co.jp/en/buy/>

