

THIS DRAWING IS UNPUBLISHED. RELEASED FOR PUBLICATION, 19
 © COPYRIGHT 19 BY AMP INCORPORATED. ALL INTERNATIONAL RIGHTS RESERVED.

LOC	DIST	P	F	REVISIONS				DATE	APPD
AF	50			ZONE	LTR	DESCRIPTION			
					N	REVISED PER 063A-0271-02	19AUG02	MF/DD	

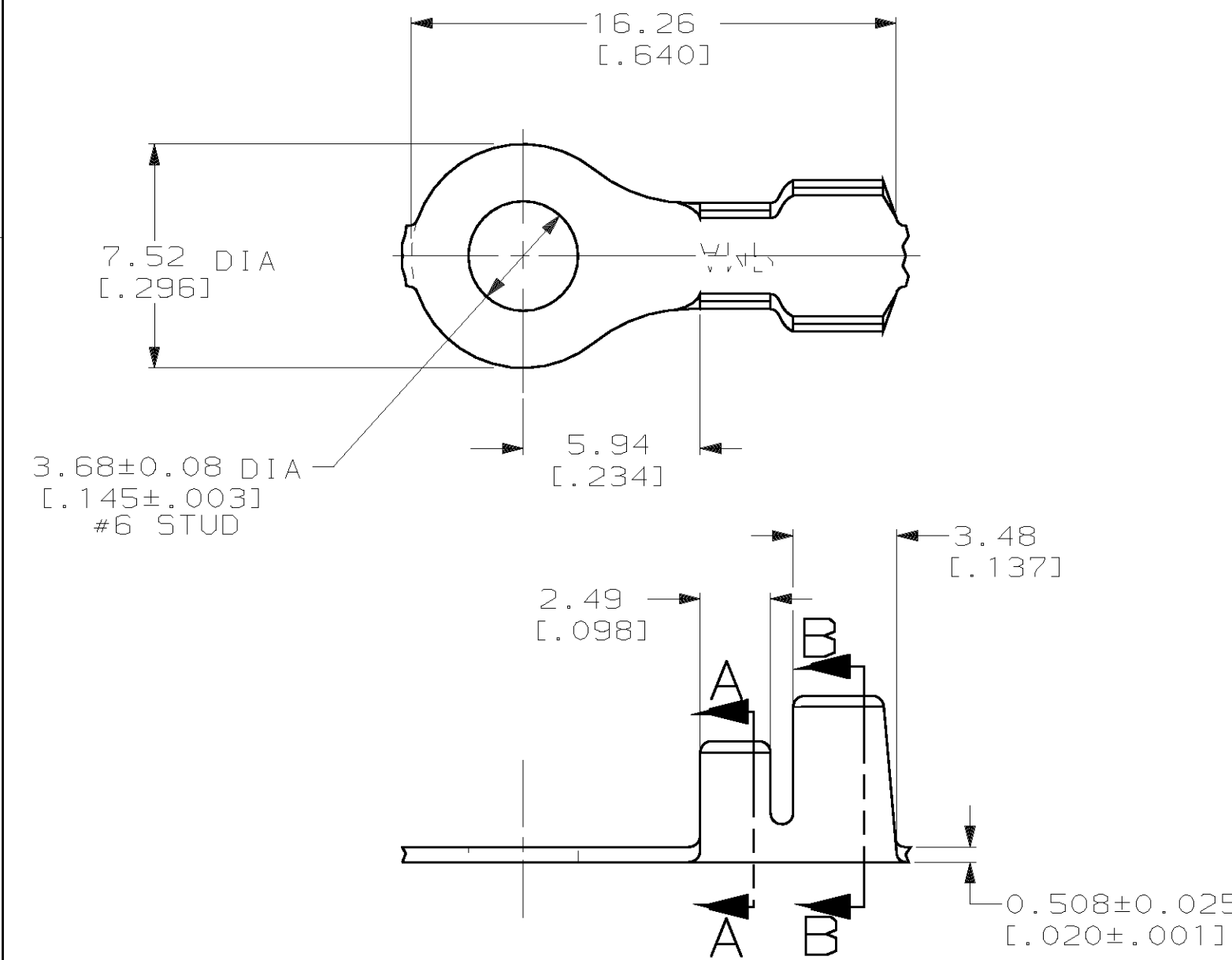

- 1 CONTINUOUS STRIP ON REEL.
- 2 0.00381 [0.000150] MIN NICKEL PLATE.

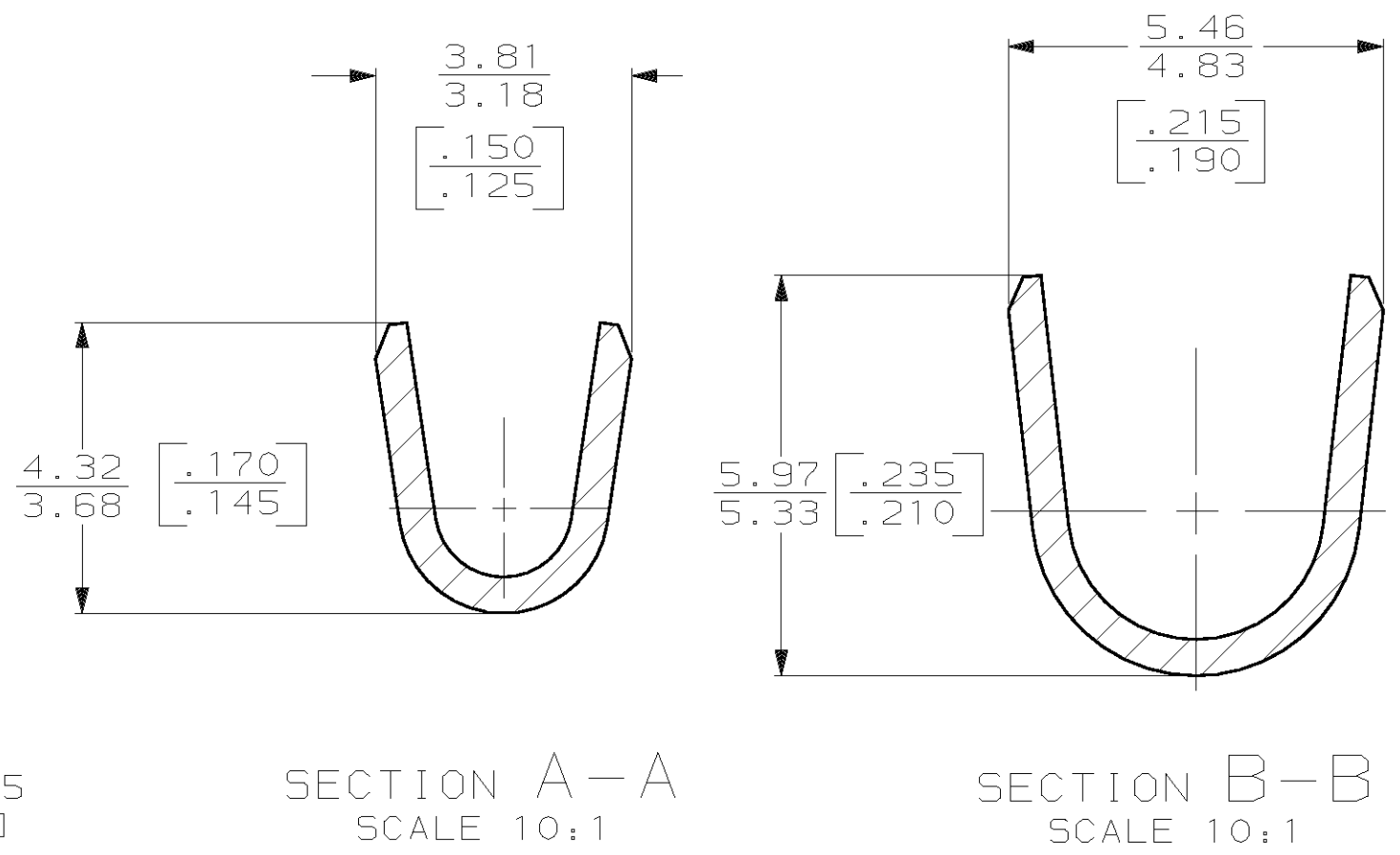

METRIC

2	#3 HARD STEEL	3.05-4.32 DIA	0.8-2.0mm	41558-1
—	082 BRASS	[.120-.170]	[18-14] AWG	41558
FINISH	MATERIAL	INSULATION RANGE	WIRE RANGE	PART NO

F OR 0	4.57 [0.180]	4.06 [0.160]	F	3.05 [0.120]	2.03 [0.080]	2.0mm [0.14]
					1.83 [0.072]	1.3mm [0.16]
					1.70 [0.067]	0.8mm [0.18]
TYPE	WIDTH	STRIP LENGTH ±0.38 [±0.015]	TYPE	WIDTH	HEIGHT ±0.051 [E.002]	WIRE
INSUL BARREL CRIMP			WIRE BARREL CRIMP			

DO NOT SCALE PRINT. UNLESS SPECIFIED DIMENSIONS IN mm [INCHES] TOLERANCES ON:
 2 PLC DEC ± 0.25 [0.010]
 3 PLC DEC ± -
 ANGLES ± -
 MATERIAL SEE TABLE
 FINISH SEE TABLE

AMP Incorporated Harrisburg, PA 17105-3608		
NAME RING		
SIZE B	CAGE CODE 00779	DRAWING NO 41558
SCALE 5:1	SHEET 1 OF 1	