



112-113 MHz LC Lowpass Filter

Part Number: AE113L8975



ANATECH ELECTRONICS INC
RF & Microwave Filters & Products

Electrical specifications

- Cutoff Frequency (FC):** 100 MHz
- Passband:** 112-113 MHz
- Insertion loss:** 0.2 dB Min
- Return loss:** 15 dB Max
- Rejection @ 700-2000 MHz:** 60 dB Max
- Rejection @ 117.5-2000 MHz:** 60 dB Max

Mechanical

- Mounting Method:** Type-N (F)
- Dimensions:** 1.125 x 1 x 0.925 Inches

Environmental

- Operating Temperature:** -40 to +85° C
- Storage Temperature:** -55 to +95° C

Outline Drawing:

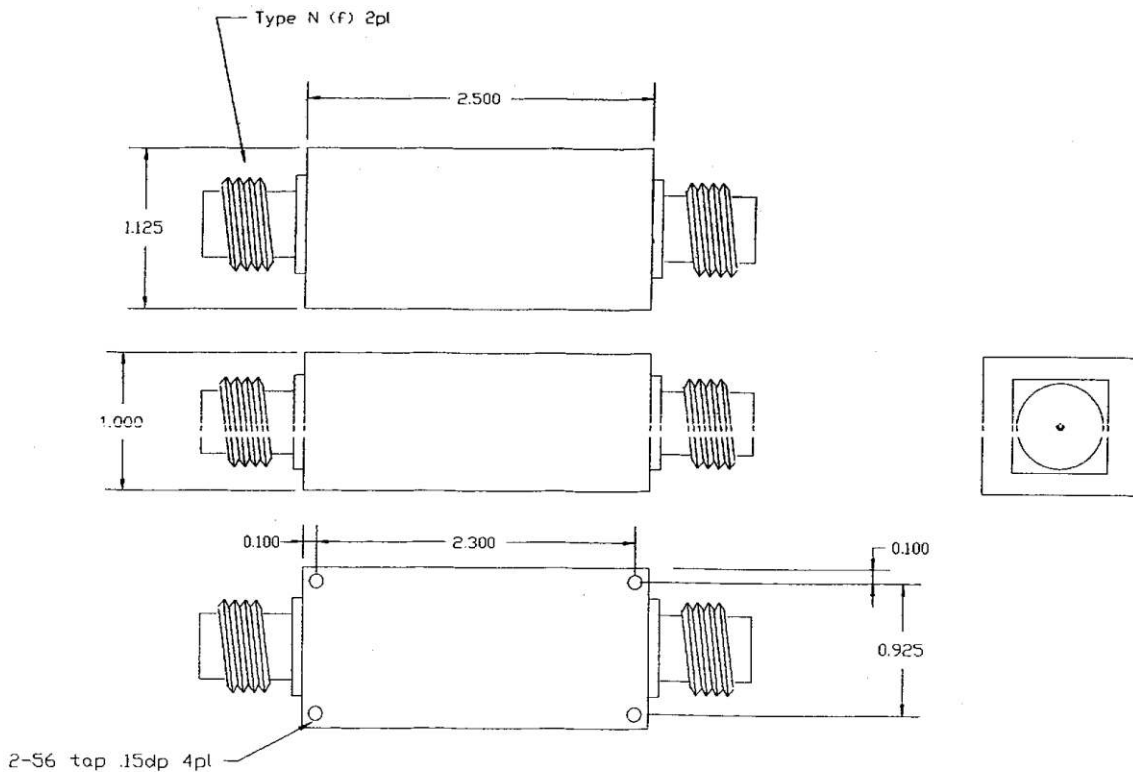

DWG 989335 ajs 1/28/08
 Outline Drawing
 Anatech Electronics Inc.
 (988773)



Response Plot

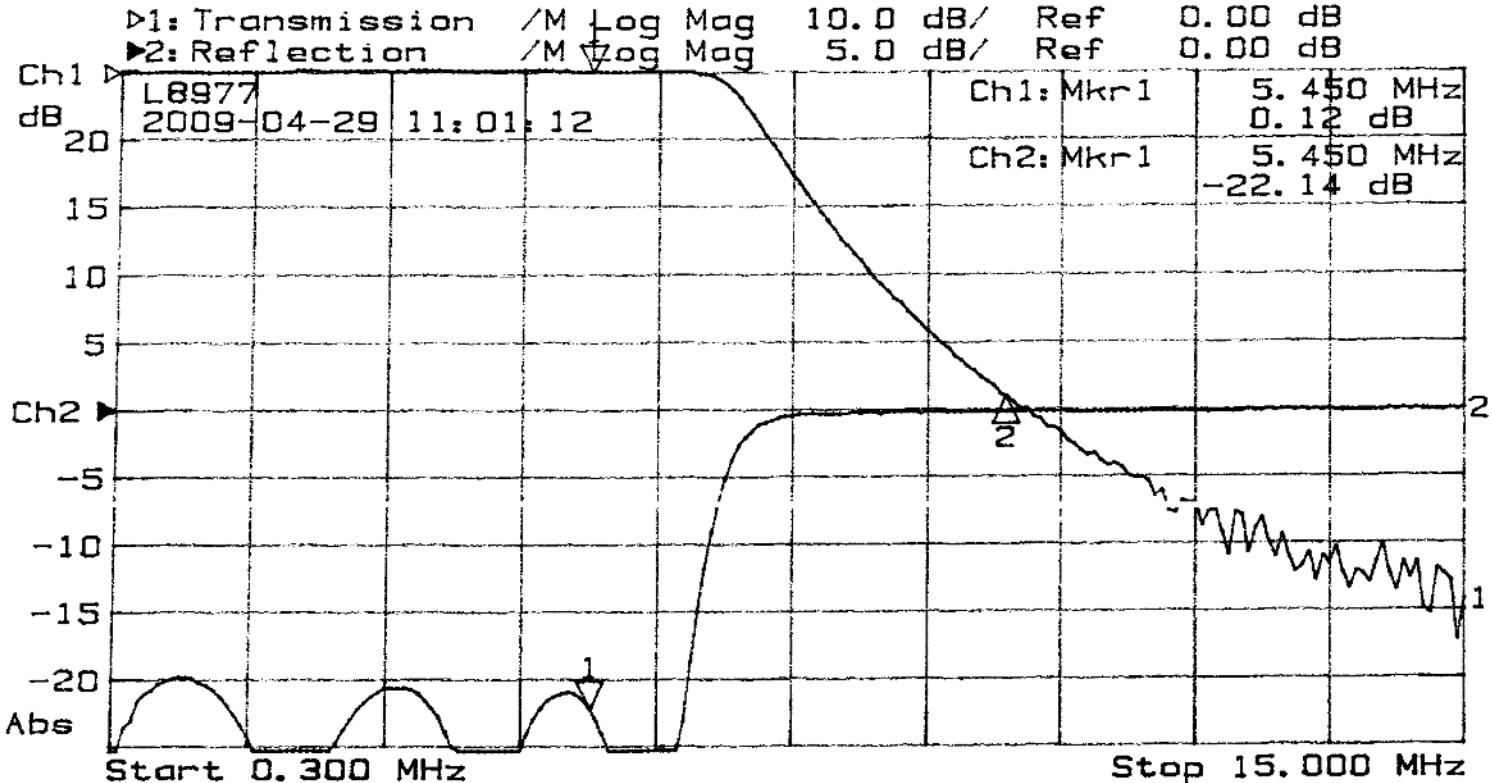

1: Mkr (MHz)	dB	2: Mkr (MHz)	dB
1> 5.45	0.12	1> 5.45	-22.14
2: 10.00	-48.14		

Kenneth S. Lower