

P	LTR	DESCRIPTION	DATE	DWN	APVD
	E	INITIAL RELEASE	23JAN2015	MM	-

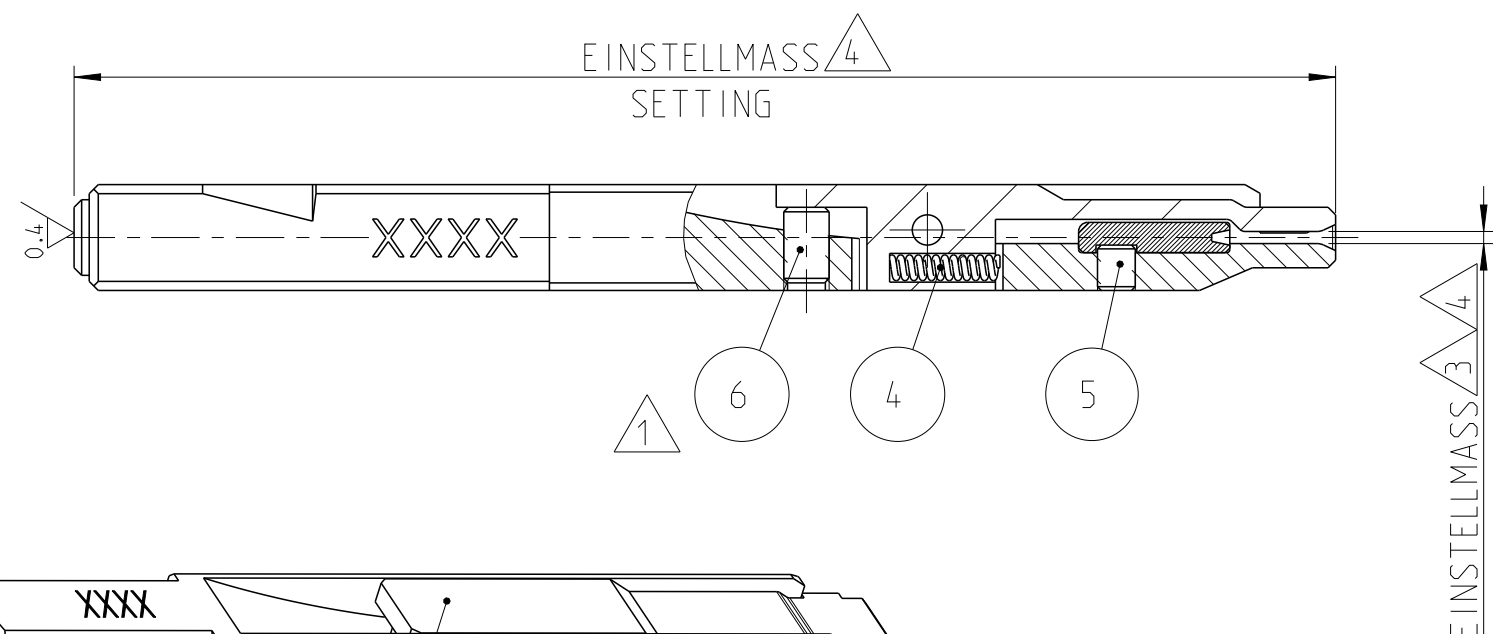

1 Mit Schraubensicherung  
Loctite 243 gesichert  
Locked with threadlocker  
Loctite 243

2 Bei Erstmontage  
vollständig einschrauben  
Insert complete for  
initial assembly

3 Öffnungsspiel Klemmhebel  
zu eingelegtem Kontakt=0.1 mm  
Opening clearance  
clamping lever to  
loaded contact=0.1 mm

4 !!!Achtung:  
Vor Einsatz im Umbausatz  
Maße kontrollieren und ggf.  
einstellen.  
Zu lang eingestellte Finger  
können zu Beschädigungen  
an Finger und Umbausatz  
führen!!!  
!!!Attention:  
Check measurement before  
using on a conversion kit.  
Too long adjusted fingers  
may damage the finger  
and conversion kit!!!

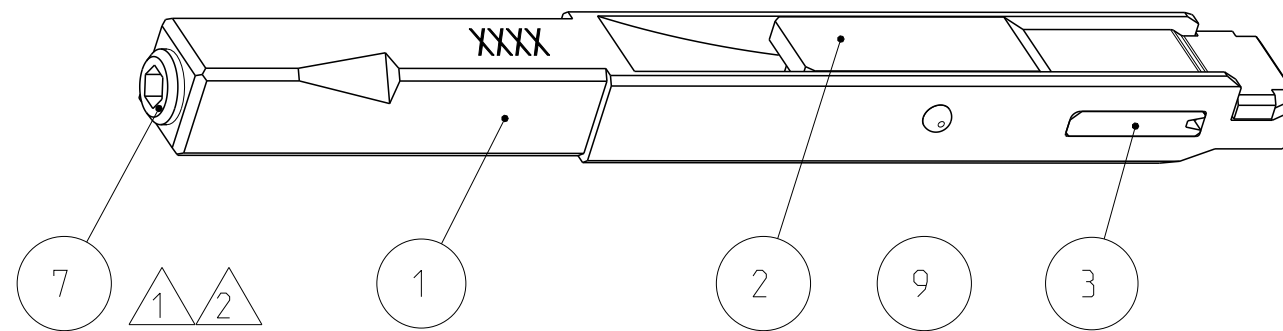

POS	QTY	TE/PN	PART REV	DESCRIPTION	WEAR	SPARE
1	1	1-1372731-0	C	SETZFINGER INSERTION FINGER	-	-
2	1	1-1372732-4	B	KLEMMHEBEL CLAMPING LEVER	-	-
3	1	8-1372493-1	B	EINSATZ INSERT	-	-
4	1	8-547505-4	A1	Druckfeder -	GUTEKUNST	D 063H-04
5	1	1-519011-2	B	SCREW M2.5x3 DIN 913 -	-	-
6	1	2-519011-0	B	SCREW M3x5 DIN 913 -	-	-
7	1	3-519011-7	B	SCREW M5x8 DIN 913 -	-	-
9	1	5-992946-2	AF1	PIN, DOWEL 2 X 10 -	-	-

THIS DRAWING IS A CONTROLLED DOCUMENT.		DWN M.BERGUNDE	23JAN2015	TE Connectivity				
DIMENSIONS: mm		CHK -	APVD -			NAME SETZFINGER KOMPLETT INSERTION FINGER COMPLETE		
TOLERANCES UNLESS OTHERWISE SPECIFIED:		PRODUCT SPEC -	APPLICATION SPEC -	SIZE A3	CAGE CODE 00779	DRAWING NO C-1372730-9	RESTRICTED TO -	
MATERIAL -		FINISH -	WEIGHT -	Customer Drawing		SCALE 2:1	SHEET 1 OF 1	REV E