

FEATURES

- 2 DAC channels: 16-, 20-, or 24-bit
- 2 ADC channels: 16- or 20-bit
- HD audio sample rates
 - 8 kHz, 11.025 kHz, 16 kHz, 22.05 kHz, 32 kHz, 44.1 kHz, 48 kHz
- Greater than 90 dB dynamic range
- S/PDIF output: 32 kHz, 44.1 kHz, or 48 kHz, 16- or 24-bit
- Digital BEEP generator
- Integrated headphone amplifiers
- Selectable microphone inputs with preamplifiers
- Stereo line level inputs
- Full analog mixer
- 2 GPIOs for external circuit control, jack sense
- 32-lead, Pb-free LFCSP_VQ (QFN) package

ENHANCED FEATURES

- No AFILT pins, results in BOM savings
- Jack sensing autoconfiguration options
 - Mute line output and monaural output (MONO_OUT) when headphones are used
 - Mute MONO_OUT when a device is in the line out jack
- Selectable sense trip level: high/low supports all jack types
- Peripheral identification/enumeration
- Jack presence detection: HD Audio SENSE and GPIOs
- Microphone to MONO_OUT for speakerphone
- Advanced power management modes
- 2 software-controlled microphone bias pins
- Stereo microphone array capture
 - Source from two different ports
 - 0 dB, 10 dB, 20 dB, and 30 dB boost options

FUNCTIONAL BLOCK DIAGRAM

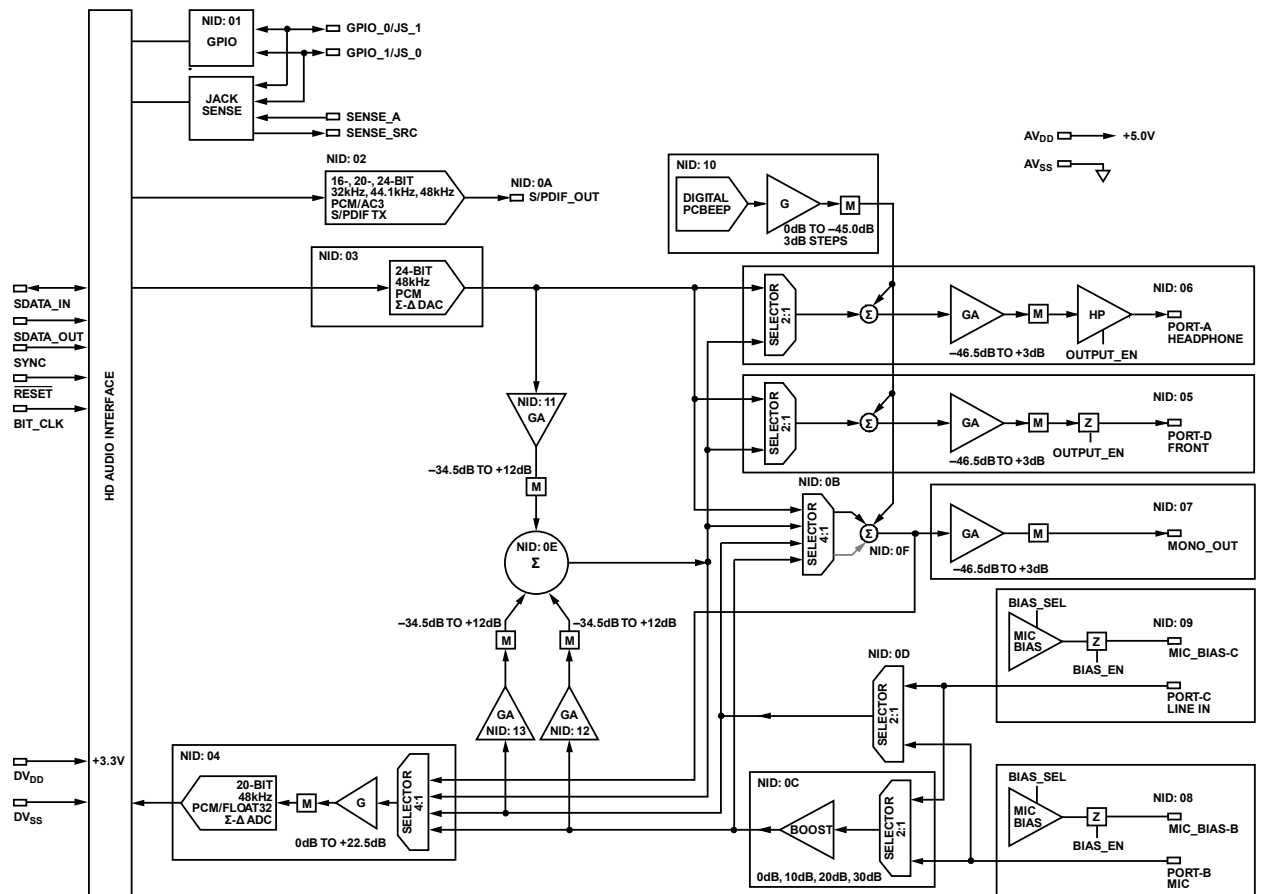

Figure 1.

Rev. 0

Information furnished by Analog Devices is believed to be accurate and reliable. However, no responsibility is assumed by Analog Devices for its use, nor for any infringements of patents or other rights of third parties that may result from its use. Specifications subject to change without notice. No license is granted by implication or otherwise under any patent or patent rights of Analog Devices. Trademarks and registered trademarks are the property of their respective owners.

TABLE OF CONTENTS

Features	1	Environmental Conditions	6
Enhanced Features.....	1	ESD Caution.....	6
Functional Block Diagram	1	Pin Configuration and Function Descriptions.....	7
Revision History	2	HD Audio Codec Information	9
Specifications.....	3	Verb Support	12
Test Conditions.....	3	Jack Presence Detection.....	14
Power Down Dissipation.....	5	Outline Dimensions	15
Absolute Maximum Ratings.....	6	Ordering Guide	15

REVISION HISTORY

4/06—Revision 0: Initial Version

SPECIFICATIONS

TEST CONDITIONS

Test conditions for the AD1983 are as follows, unless otherwise noted.

General Test Conditions

Temperature at 25°C

Digital supply (DV_{DD}) at 3.3 V \pm 10%

Analog supply (AV_{DD}) at 5.0 V \pm 10%

Sample rate (F_s) at 48 kHz

Input signal at 1.0 kHz

Analog output pass band at 20 Hz to 20,000 Hz

V_{IH} at 2.0 V

V_{IL} at 0.8 V

V_{IH} at 2.4 V

V_{IL} at 0.6 V

DAC Test Conditions

Calibrated

Output -3 dB relative to full scale

10 k Ω output load, Port D, and MONO_OUT

32 Ω output load, Port A

ADC Test Conditions

Calibrated

0 dB PGA gain

Input -3.0 dB relative to full scale

Table 1.

Parameter	Conditions	Min	Typ	Max	Unit
ANALOG INPUT					
Port-B, Port-C	0 dB		1		V_{rms}^1
			2.83		V_{p-p}
Port-B, Port-C	10 dB		0.316		V_{rms}
			0.894		V_{p-p}
Port-B, Port-C	20 dB		0.1		V_{rms}
			0.283		V_{p-p}
Port-B, Port-C	30 dB		0.032		V_{rms}
			0.089		V_{p-p}
Input Impedance ²			20		k Ω
Input Capacitance ²			5	7.5	pF
MASTER VOLUME					
Step Size	Port-A, Port-D, MONO_OUT		1.5		dB
Output Gain Range		-46.5		$+3$	dB
Mute Attenuation of 0 dB Fundamental		80			dB
PROGRAMMABLE GAIN AMPLIFIER—ADC					
Step Size			1.5		dB
PGA Gain Range		0.0		22.5	dB
ANALOG MIXER—INPUT GAIN/AMPLIFIERS/ATTENUATORS					
Signal-to-Noise Ratio (SNR)					
Line In to Line Out			85		dB
Microphone In to Line Out ²			80		dB
Step Size	All mixer inputs except digital PC BEEP		1.5		dB
Step Size: Digital PC Beep			3.0		dB
Input Gain Range	All mixer inputs except digital PC BEEP	-34.5		$+12.0$	dB
Digital PC Beep		-45.0		0.0	dB
DIGITAL DECIMATION AND INTERPOLATION FILTERS ²					
Pass Band		0		$0.4 \times F_s$	Hz
Pass-Band Ripple				± 0.09	dB
Transition Band		$0.4 \times F_s$		$0.6 \times F_s$	Hz
Stop Band		$0.6 \times F_s$		∞	Hz
Stop-Band Rejection		-74			dB

AD1983

Parameter	Conditions	Min	Typ	Max	Unit
Group Delay			16/F _S		sec
Group Delay Variation over Pass Band			0		μs
ANALOG-TO-DIGITAL CONVERTERS					
Resolution			+20		Bits
Total Harmonic Distortion (THD)			-92		dB
Dynamic Range	-60 dB input, THD + N referenced to F _S , A-weighted		-85		dB
Crosstalk ²	Line inputs: Input L, Ground R, Read R; Input R, Ground L, Read L		-80		dB
Gain Error	Line inputs and other inputs		-100	-80	dB
Interchannel Gain Mismatch	Full-scale span relative to nominal input voltage		±10		%
ADC Offset Error ²	Difference of gain errors			±0.5	dB
				±5	mV
DIGITAL-TO-ANALOG CONVERTERS					
Resolution			+24		Bits
Total Harmonic Distortion (THD)	Line out		-86		dB
	Headphone out		-76		dB
Dynamic Range	-60 dB input, THD + N referenced to F _S , A-weighted		-90		dB
Gain Error	Full-scale span relative to nominal input voltage		±10		%
Interchannel Gain Mismatch	Difference of gain errors			±0.7	dB
DAC Crosstalk ²	Input L, Zero R, Read R out; Input R, Zero L, Read L out			-80	dB
ANALOG OUTPUT					
Full-Scale Output Voltage	Port-D and MONO_OUT		1		V rms
			2.83		V p-p
Output Impedance ²			300		Ω
External Load Impedance ²		10			kΩ
Output Capacitance ²			15		pF
External Load Capacitance				1000	pF
Full-Scale Output Voltage	Port-A: headphone out		1		V rms
			2.83		V p-p
External Load Impedance ²		32			Ω
Output Capacitance ²			15		pF
External Load Capacitance ²				1000	pF
VREF_FILTER		2.050	2.250	2.450	V
MIC_BIAS (Port-B and Port-C)	At 50% setting		2.250		V
	At 80% setting		3.700		V
	At 0% setting		0.0		V
Current Drive				5	mA
Mute Click	Muted output, unmuted midscale DAC output		±5		mV
STATIC DIGITAL SPECIFICATIONS					
High Level Input Voltage (V _{IH}), Digital Inputs		0.65 × DV _{DD}			V
Low Level Input Voltage (V _{IL})			0.35 × DV _{DD}		V
High Level Output Voltage (V _{OH})	I _{OH} = 2 mA	0.90 × DV _{DD}			V
Low Level Output Voltage (V _{OL})	I _{OL} = 2 mA		0.10 × DV _{DD}		V
Input Leakage Current		-10	+10		μA
Output Leakage Current		-10	+10		μA
Input/Output Pin Capacitance			7.5		pF

Parameter	Conditions	Min	Typ	Max	Unit
POWER SUPPLY					
Power Supply Range					
Analog	(AV _{DD}) ±10%	4.5		5.5	V
Digital	(DV _{DD}) ±10%	2.97		3.63	V
Power Dissipation—Analog (AV _{DD})/Digital (DV _{DD})			165/125		mW
Analog Supply Current—Analog (AV _{DD})			33		mA
Digital Supply Current—Digital (DV _{DD})			38		mA
Power Supply Rejection	100 mV p-p signal @ 1 kHz		40		dB

¹ RMS values assume sine wave input.

² Guaranteed by design; not production tested.

POWER DOWN DISSIPATION

Table 2.

Parameter	DV _{DD}	AV _{DD}	Unit
FUNCTION NODE ¹	0	1.8	mA
DAC	30	26	mA
ADC	28	26	mA
MIXER	37	17	mA

¹ BIT_CLK off.

ABSOLUTE MAXIMUM RATINGS

Table 3.

Parameter	Rating
Digital (DV_{DD})	-0.3 V to +3.6 V
Analog (AV_{DD})	-0.3 V to +6.0 V
Input Current (Except Supply Pins)	± 10.0 mA
Analog Input Voltage (Signal Pins)	-0.3 V to $AV_{DD} + 0.3$ V
Digital Input Voltage (Signal Pins)	-0.3 V to $DV_{DD} + 0.3$ V
Ambient Temperature (Operating)	
Commercial Range	0°C to 70°C
Industrial Range	-40°C to +85°C
Storage Temperature Range	-65°C to +150°C

Stresses above those listed under Absolute Maximum Ratings may cause permanent damage to the device. This is a stress rating only; functional operation of the device at these or any other conditions above those indicated in the operational section of this specification is not implied. Exposure to absolute maximum rating conditions for extended periods may affect device reliability.

ENVIRONMENTAL CONDITIONS

Table 4. Thermal Resistance

Package	θ_{JA} ¹	θ_{JC}^2 (bottom)	θ_{JC}^2 (top)	Unit
LFCS_P_VQ	58.8	1.52	23.69	°C/W

¹ θ_{JA} is the thermal resistance (junction-to-ambient). Bottom pad not soldered.

² θ_{JC} is the thermal resistance (junction-to-case). Bottom pad not soldered.

ESD CAUTION

ESD (electrostatic discharge) sensitive device. Electrostatic charges as high as 4000 V readily accumulate on the human body and test equipment and can discharge without detection. Although this product features proprietary ESD protection circuitry, permanent damage may occur on devices subjected to high energy electrostatic discharges. Therefore, proper ESD precautions are recommended to avoid performance degradation or loss of functionality.



PIN CONFIGURATION AND FUNCTION DESCRIPTIONS

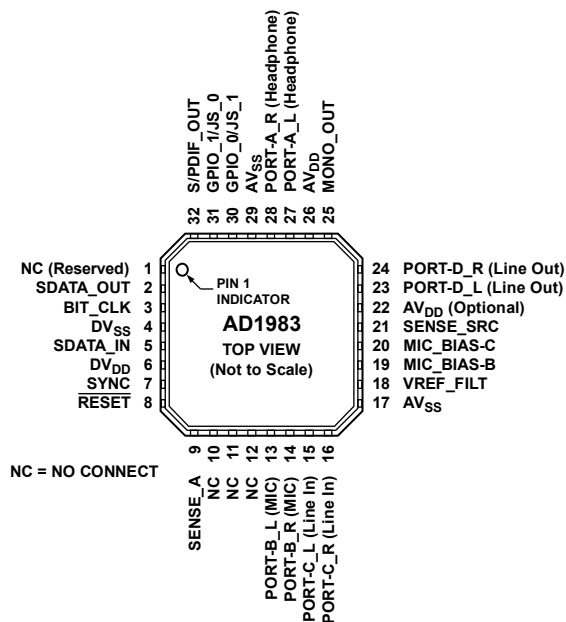

Figure 2. Pin Configuration

Table 5. Pin Function Descriptions

Mnemonic	Pin No.	I/O ¹	Description
SDATA_OUT	2	I	HD Audio Link Serial Data Output. Codec input stream.
BIT_CLK	3	I	HD Audio Link Bit Clock Input. 24 MHz.
SDATA_IN	5	I/O	HD Audio Link Serial Data Input. Codec output stream.
SYNC	7	I	HD Audio Link Frame Sync.
RESET	8	I	HD Audio Link Reset. Master hardware reset.
GPIO_1/JS_0	31	Digital I/O	GPIO_1: General Purpose Input/Output Pin. Digital signal used for circuit control. JS_0: Classical (DC) Jack Sense for Line_Out Pins. Low = jack not present, high = jack present.
GPIO_0/JS_1	30	Digital I/O	GPIO_0: General Purpose Input/Output Pin. Digital signal used circuit control. JS_1: Classical (DC) Jack Sense for Headphone. Low = jack not present, high = jack present.
SENSE_A	9	Digital I	Jack Sense Input for Presence Detect on Port A Through Port D. Used with isolated switches on audio jacks.
SENSE_SRC	21	Digital O	Connect via 2.67 kΩ 1% resistor to Pin 9 (SENSE_A) when using the SENSE_A functionality. This reduces the current draw of the jack presence tree during idle states. Remove the resistor between Pin 9 and AV _{DD} in this mode.
PORT-B_L (MIC)	13	Analog I	Microphone or Line-In Left Input.
PORT-B_R (MIC)	14	Analog I	Microphone or Line-In Right Input.
PORT-C_L (Line In)	15	Analog I	Line-In or Microphone Left Input.
PORT-C_R (Line In)	16	Analog I	Line-In or Microphone Right Input.
PORT-D_L (Line Out)	23	Analog O	Line-Out-(Front)-Left Channel.
PORT-D_R (Line Out)	24	Analog O	Line-Out-(Front)-Right Channel.
MONO_OUT	25	Analog O	Monaural Output to Telephony Subsystem Speakerphone.
PORT-A_L (Headphone)	27	Analog O	Headphone-Out-Left Channel.
PORT-A_R (Headphone)	28	Analog O	Headphone-Out-Right Channel.
VREF_FILT	18	O	Voltage Reference Filter.
MIC_BIAS-B	19	O	Programmable Microphone Bias Output. Intended for connection to Port-B.

AD1983

Mnemonic	Pin No.	I/O¹	Description
MIC_BIAS-C	20	O	Programmable Microphone Bias Output. Intended for connection to Port-C.
DV _{SS}	4	I	Digital Supply Return (Ground).
DV _{DD}	6	I	Digital Supply Voltage (3.3 V).
AV _{SS}	17, 29	I	Analog Supply Return (Ground).
AV _{DD}	22, 26	I	Analog Supply Voltage (5.0 V). AV _{DD} supplies should be well filtered because supply noise degrades audio performance. Connection to Pin 22 is optional.
S/PDIF_OUT	32	Digital O	Supports S/PDIF Output.
NC	1, 10 to 12		

¹ I refers to input and O refers to output.

HD AUDIO CODEC INFORMATION

Table 6. Widget List and Descriptions

NID (Hex)	Name	Type ID	Type	Description
00	ROOT	x	Root	Device identification.
01	FUNCTION	x	Function	Designates this device as an audio codec.
02	S/PDIF	0	Audio output	Designates the codec S/PDIF digital stream output interface.
03	Front DAC	0	Audio output	Designates the playback channel digital/audio converters.
04	Record ADC	1	Audio input	Designates the record channel audio/digital converters.
05	Port-D (Line Out)	4	Pin complex	Port-D pin drivers. Typically used as rear panel line output.
06	Port-A (Headphone Out)	4	Pin complex	Port-A pin drivers. Typically used as front panel headphone output.
07	MONO_OUT	4	Pin complex	Monaural output pin driver. Typically used to drive an internal speaker or as a microphone selector on a telephony system.
08	Port-B (Front Microphone)	4	Pin complex	Port-B pin drivers. Typically used as front panel microphone.
09	Port-C (Line In)	4	Pin complex	Port-C pin drivers. Typically used as rear panel line input.
0A	S/PDIF_OUT	4	Pin complex	S/PDIF output digital interface.
0B	Mono Selector	3	Audio selector	Chooses the signals that drive the mono output mixer and pin.
0C	Microphone Selector/Boost	3	Audio mixer	Allows microphone source port selection and boost preamplifier setting.
0D	Line In Selector	3	Audio selector	Allows line in source port selection.
0E	Analog Mixer	2	Audio mixer	Selectively mixes analog input signals into a single signal.
0F	Mono Mixer	2	Audio mixer	Stereo-to-Mono mixer.
10	Digital PC Beep	7	Beep generator	Digital PC beep generator.
11	Front Mix Amp	3	Audio selector	Individual gain control for the DAC (front) input to the analog mixer.
12	Port-B Mix Amp	3	Audio selector	Individual gain control for the Port-B (front microphone) input to the analog mixer.
13	Port-C Mix Amp	3	Audio selector	Individual gain control for the Port-C (line in) input to the analog mixer.
14	Record Selector	3	Audio selector	Chooses the signal that is recorded by the record ADC. Also contains the record gain controls.
15	Analog Power-Down	5	Power widget	Controls power on analog mixer and associated amplifiers. This controls the power of all widgets in its connection list.

Table 7. Root and Function Node Parameters¹

NID (Hex)	Name	Type ID	Type	Vendor ID PID 00 ²	Revision ID PID 02 ²	Sub Node Count PID 04 ²	Function Group Type PID 05 ²	Audio F.G. Caps PID 08 ²	GPIO Caps PID 11 ²
00	ROOT	X	Root	11D41983	00100400	00010001			
01	FUNCTION	X	Function			00020014	00000001	00010C0C	40000002

¹ Default SSID: BFD30000.

² PID = parameter ID.

AD1983

Table 8. Widget Parameters

NID (Hex)	Name	Widget Caps PID 09 ¹	PCM Size, Rate PID 0A ¹	Stream Format PID 0B ¹	Pin Caps PID 0C ¹	Input Amp Caps PID 0D ¹	Con. List Len PID 0E ¹	Power States PID 0F ¹	Processing Caps PID 10 ¹	GPIO Caps PID 11 ¹	Vendor- Specific PID F0 ¹
01	FUNCTION	000004C0	000E007F	00000001		00000000		00000009	00000001	80053F3D	00000084
02	S/PDIF	00030311	00020060	00000005			00000002				
03	Front DAC	00000441	000E007F	00000001			00000000	00000009	00004601		00000010
04	Record ADC	00100501	000E007F	00000001			00000001	00000009			
05	Port-D (Line Out)	00400185			00000017		00000002			80053F3D	00000008
06	Port-A (Headphone Out)	00400185			0000001F		00000002			80053F3D	00000008
07	MONO_OUT	00400104			00000010		00000001			80053F3D	
08	Port-B (Front Microphone)	00400081			00001727		00000000				00000008
09	Port-C (Line In)	00400081			00001727		00000000				00000008
0A	S/PDIF_OUT	00400301			00000010		00000001				
0B	Mono Selector	00300101					00000004				
0C	Microphone Selector/Boost	0030010D					00000002			00270300	
0D	Line In Selector	00300101					00000002				
0E	Analog Mixer	00200101					00000003				
0F	Mono Mixer	00200100					00000001				00000002
10	Digital PC Beep	0070000C					00000000			800B0F0F	
11	Front Mix Amp	0030010D					00000001			80051F17	
12	Port-B Mix Amp	0030010D					00000001			80051F17	
13	Port-C Mix Amp	0030010D					00000001			80051F17	
14	Record Selector	0030010D					00000004			80050F00	
15	Analog Power- Down	00500500					00000004	00000009			

¹ PID = parameter ID.

Table 9. Default Configuration Parameters

Node ID (Hex)	Name	Type ID	Bit	31	29	27	23	19	15	8	7	3
			Bit	30	28	24	20	16	12	8	4	0
			Value	Connect	Location		Def. Device	Conn. Type	Color	Misc.	Def. Assn.	Sequence
				Chassis	Position				Ovrrd.			
05	Line Out	4	01014010	Jack	External	Rear	Line Out	1/8" Jack	Green	0	1	0
06	HP Out	4	0221401F	Jack	External	Front	HP Out	1/8" Jack	Green	0	1	F
07	Mono Out	4	991301F0	Fixed	Internal	Special 3	Speaker	ATAPI	Unknown	1	F	0
08	Microphone In	4	02A19020	Jack	External	Front	Mic In	1/8" Jack	Pink	0	2	0
09	Line In	4	0181302E	Jack	External	Rear	Line In	1/8" Jack	Blue	0	2	E
0A	S/PDIF Out	4	014511F0	Jack	External	Rear	SPDIF Out	Optical	Black	1	F	0

Table 10. Widget Connection List

NID (Hex)	Name	Index			
		0	1	2	3
		NID (Hex)	NID (Hex)	NID (Hex)	NID (Hex)
02	S/PDIF	01	04		
03	Front DAC				
04	Record ADC	14			
05	Port-D (Line Out)	03	0E		
06	Port-A (Headphone Out)	03	0E		
07	MONO_OUT	0F			
08	Port-B (Front Microphone)				
09	Port-C (Line In)				
0A	S/PDIF_OUT	02			
0B	Mono Selector	03	0C	0D	0E
0C	Microphone Selector/Boost	08	09		
0D	Line In Selector	09	08		
0E	Analog Mixer	11	12	13	
0F	Mono Mixer	0B			
10	Digital PC Beep				
11	Front Mix Amp	03			
12	Port-B Mix Amp	0C			
13	Port-C Mix Amp	0D			
14	Record Selector	0C	0D	0E	0F
15	Analog Power-Down	05	09	0B	14

AD1983

VERB SUPPORT

Table 11 and Table 12 list only those HD audio verbs that are supported.

Table 11. Widget Verb Support

Node ID (Hex)	Name	Stream Format	Amplifier Gain/Mute	Processing Coefficient	Coefficient Index	Parameter	Connection Select	Connection List Entry	Processing State	SDI Select	Power State	Channel / Stream ID	Pin Widget Control	Unsolicited Enable	Pin Sense	Beep Generator	Digital Converter 1	Digital Converter 2	
		Get (Hex)	Bxx	Cxx	Dxx	F00	F01	F02	F03	F04	F05	F06	F07	F08	F09	F0A	F0D		
		Set (Hex)	2xx	3xx	4xx	5xx	---	701	---	703	704	705	706	707	708	709	70A	70D	70E
00	ROOT					√													
01	FUNCTION			S ¹	S ¹	√			U ²		√			√					
02	S/PDIF	√				√	√	√	S ¹	U ²		√					√	√	
03	Front DAC	√		√	√	√			√	U ²	√	√							
04	Record ADC	√				√		√		U ²	√	√							
05	Line Out		√			√	√	√					√	√	√				
06	HP Out		√			√	√	√					√	√	√				
07	Mono Out		√			√		√					√						
08	Microphone In					√							√	√	√				
09	Line In					√							√	√	√				
0A	S/PDIF Out					√		√					√						
0B	Mono Selector					√	√	√											
0C	Microphone Selector		√			√	√	√											
0D	Line In Selector					√	√	√											
0E	Analog Mixer					√		√											
0F	Mono Mixer					√		√											
10	Digital PCBeep		√			√										√			
11	Front MixAmp		√			√		√											
12	Microphone MixAmp		√			√		√											
13	Line In MixAmp		√			√		√											
14	ADC Selector		√			√	√	√											
15	Analog Power Down					√		√			√								

¹ S = supports ADI specific functionality. Refer to the Programming Guide for more details (available from your assigned Applications Engineer).

² U = unsupported in the AD1983; the get verb always returns 0, the set verbs are ignored.

Table 12. Widget Extended Verb Support

Node ID	Name	Get (Hex)	GPI/O Data	GPI/O Enable	GPI/O Direction	GPI/O Wake Mask	GPI/O Unsolicited	GPI/O Sticky Mask	Config Def Byte1	Config Def Byte2	Config Def Byte3	Config Def Byte4	Subsystem ID Byte1	Subsystem ID Byte2	Subsystem ID Byte3	Subsystem ID Byte4
			F15	F16	F17	F18	F19	F1A	F1C				F20			
			715	716	717	718	719	71A	71C	71D	71E	71F	720	721	722	723
01 ¹	FUNCTION		√	√	√	U ²	√	U ²					√	√	√	√
05	Line Out								√	√	√	√				
06	HP Out								√	√	√	√				
07	Mono Out								√	√	√	√				
08	Microphone								√	√	√	√				
09	Line In								√	√	√	√				
0A	S/PDIF Out								√	√	√	√				

¹ Only the FUNCTION node (Node ID 01) supports the RESET Verb 7FF (set verb only).

² U = unsupported in the AD1983. The get verb always returns 0, and the set verbs are ignored.

JACK PRESENCE DETECTION

The AD1983 uses one jack sense line for presence detection on up to four external jacks. This enables software to determine if there is a device plugged into a jack; then, the AD1983 sensing engine can determine what type of device it is. Jack presence is detected using a resistor tree arrangement outlined in the HD Audio specification. Up to four jacks can be sensed on a single sense line by using a different value resistor for each between the sense line and ground (AV_{SS}). Jacks must have normally-open, isolated switches to use this method of jack presence detection.

For proper operation there must be a $2.67\text{ k}\Omega$ 1% resistor connected between $SENSE_A$ and AV_{DD} . For this configuration R1 and C1 should be installed; R2 should not be installed (see Figure 3).

The specific resistor values for each jack are shown in Table 13. To ensure accurate detection, use 1% tolerance resistors for all jack presence circuitry.

Table 13. Jack Sense Mapping

Resistor (1%)	SENSE_A		
	Name	Port	Node ID (Hex)
5.1 k Ω	Line Out	D	05
10.0 k Ω	Line In	C	09
20.0 k Ω	Microphone	B	08
39.2 k Ω	Headphone Out	A	06

An alternate method reduces the current for sensing by connecting a single $2.67\text{ k}\Omega$ 1% resistor between the $SENSE_A$ and $SENSE_SRC$ pins. For this configuration R1 and C1 are not installed; however, R2 is installed (see Figure 3).

It is recommended that designers place circuitry for both sensing methods and only install one of the two options.

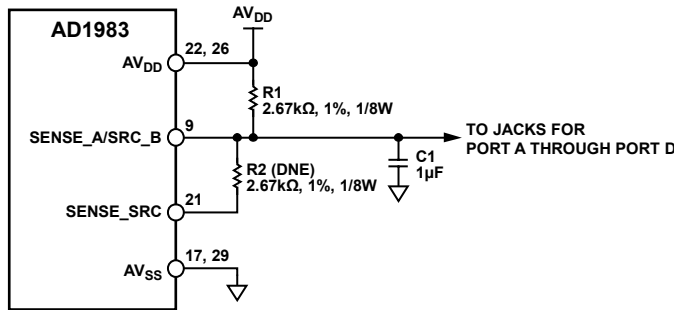

Figure 3. Jack Presence Detection

05205-013

AD1983

NOTES