



All numerical values are in metric units [with U.S. customary units in brackets]. Dimensions are in millimeters. Unless otherwise specified, dimensions have a tolerance of ± 0.13 mm and angles have a tolerance of $\pm 2^\circ$. Figures and illustrations are for identification only and are not drawn to scale.

1. INTRODUCTION

This specification covers the requirements for application of the Z-PACK TinMan connector system. This connector system uses a modular concept and interconnects two printed circuit (pc) boards. Both pin and receptacle connectors are connected to the pc board via compliant press-fit contacts.

The Z-PACK TinMan connectors are available in a vertical or right-angle press-fit pin header and vertical or right-angle press-fit receptacle. The headers are available with open-end, right wall, left wall, or double-end walls.

Typical densities are as follows: 6-pair, 16 column connector with open-end provides 79 contact pairs per 25.4 mm; 5-pair, 16 column connector with open-end provides 66 contact pairs per 25.4 mm; 4-pair, 16 column connector with open-end provides 53 contact pairs per 25.4 mm; and the 3-pair, 16 column connector with open-end provides 40 contact pairs per 25.4 mm. Universal guide modules are also available and should be used in conjunction with the Z-PACK TinMan connector.

When corresponding with TE Connectivity (TE) personnel, use the terminology provided in this specification to facilitate your inquiries for information. Basic terms and features of this product are provided in Figure 1.

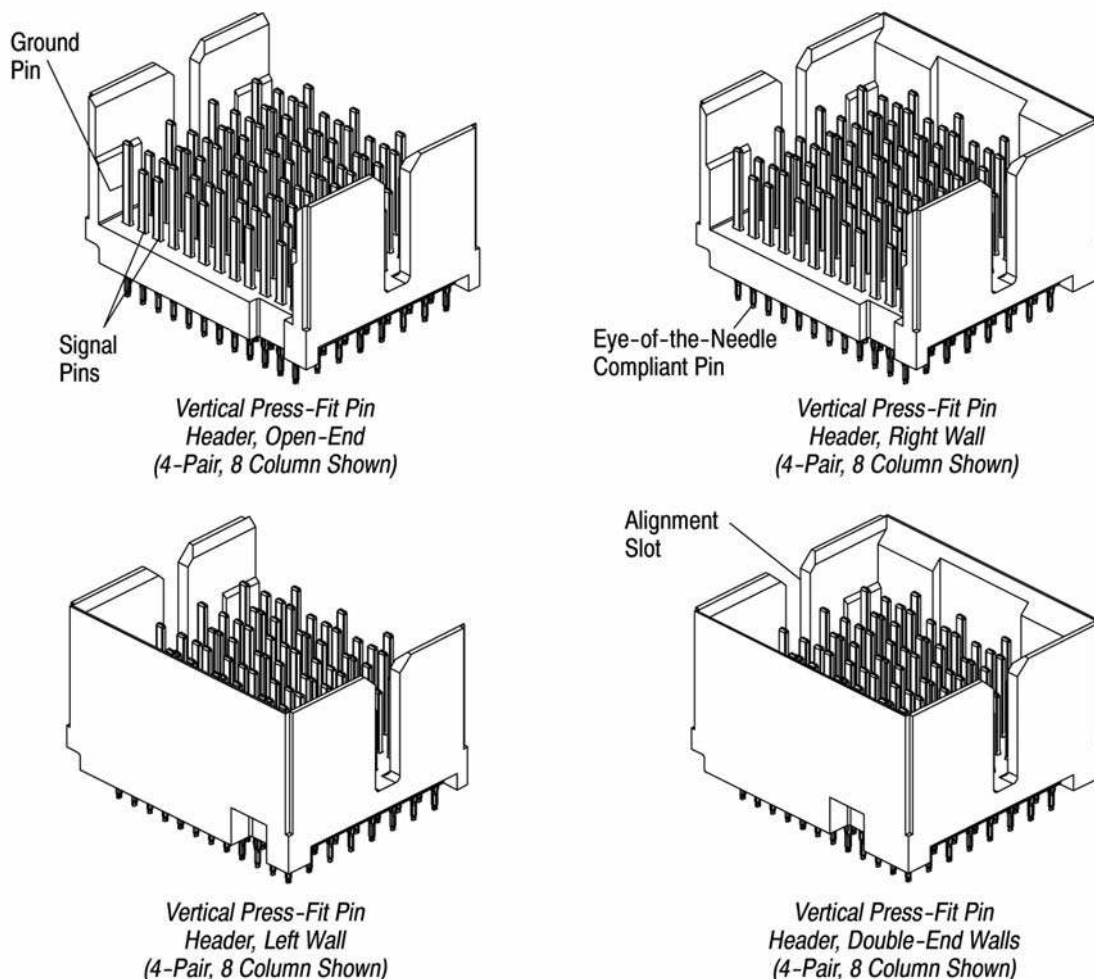
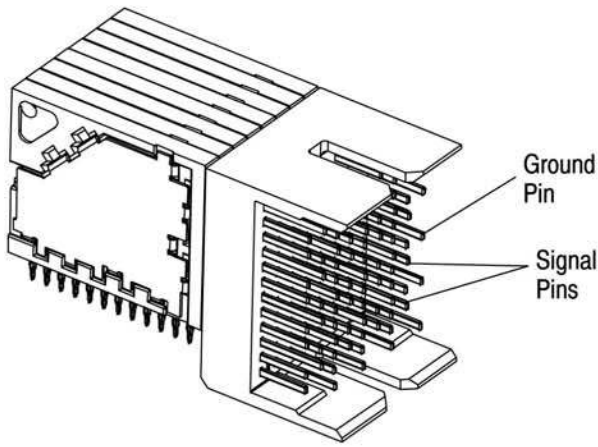
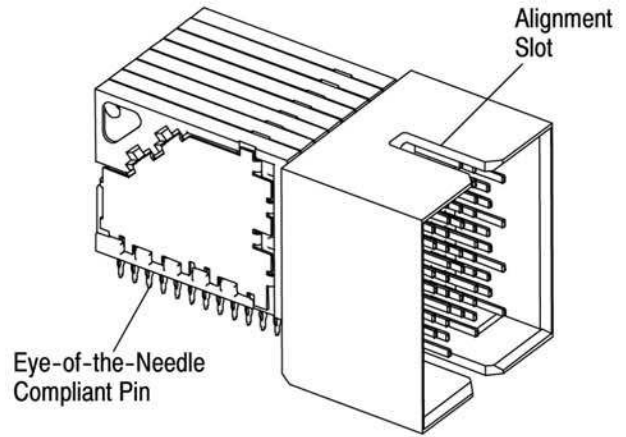

Figure 1 (Cont'd)



Right-Angle Press-Fit Pin Header, Open-End (4-Pair, 8 Column Shown)



Right-Angle Press-Fit Pin Header, Double-End Walls (4-Pair, 8 Column Shown)

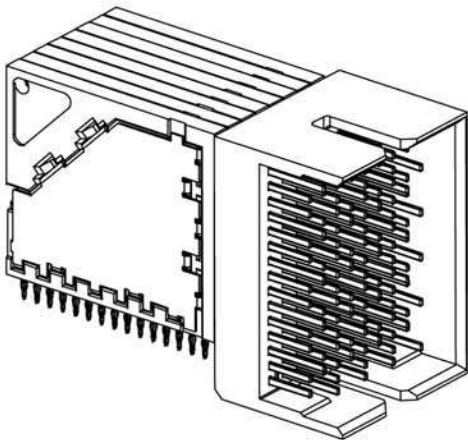

Right-Angle Press-Fit Pin Header, Right-End Wall (4-Pair, 8 Column Shown)

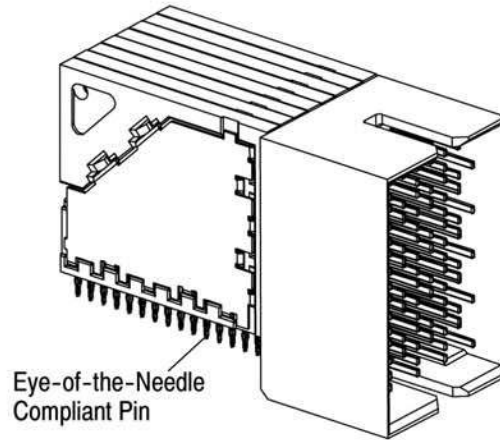

Right-Angle Press-Fit Pin Header, Left-End Wall (4-Pair, 8 Column Shown)

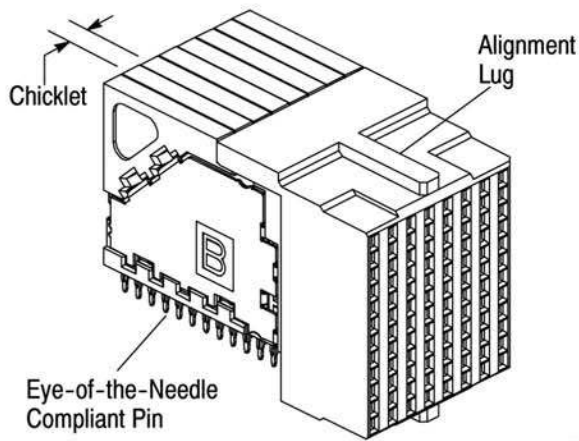

Right-Angle Press-Fit Receptacle (4-Pair, 8 Column Shown)

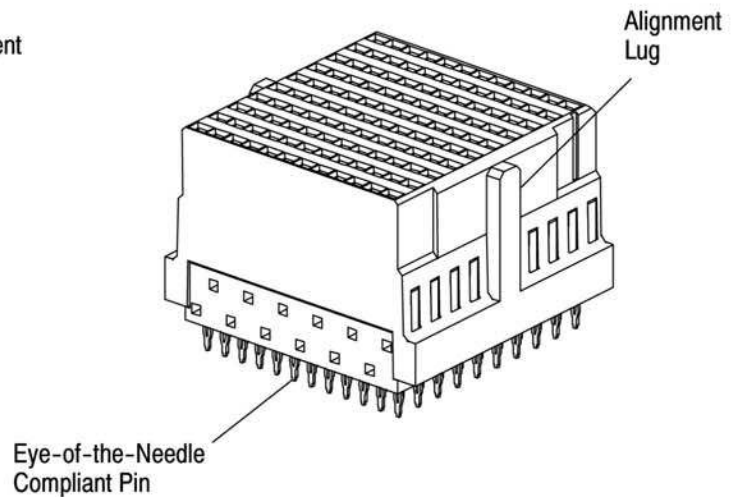

Vertical Press-Fit Receptacle (4-Pair, 8 Column Shown)

Figure 1 (Cont'd)

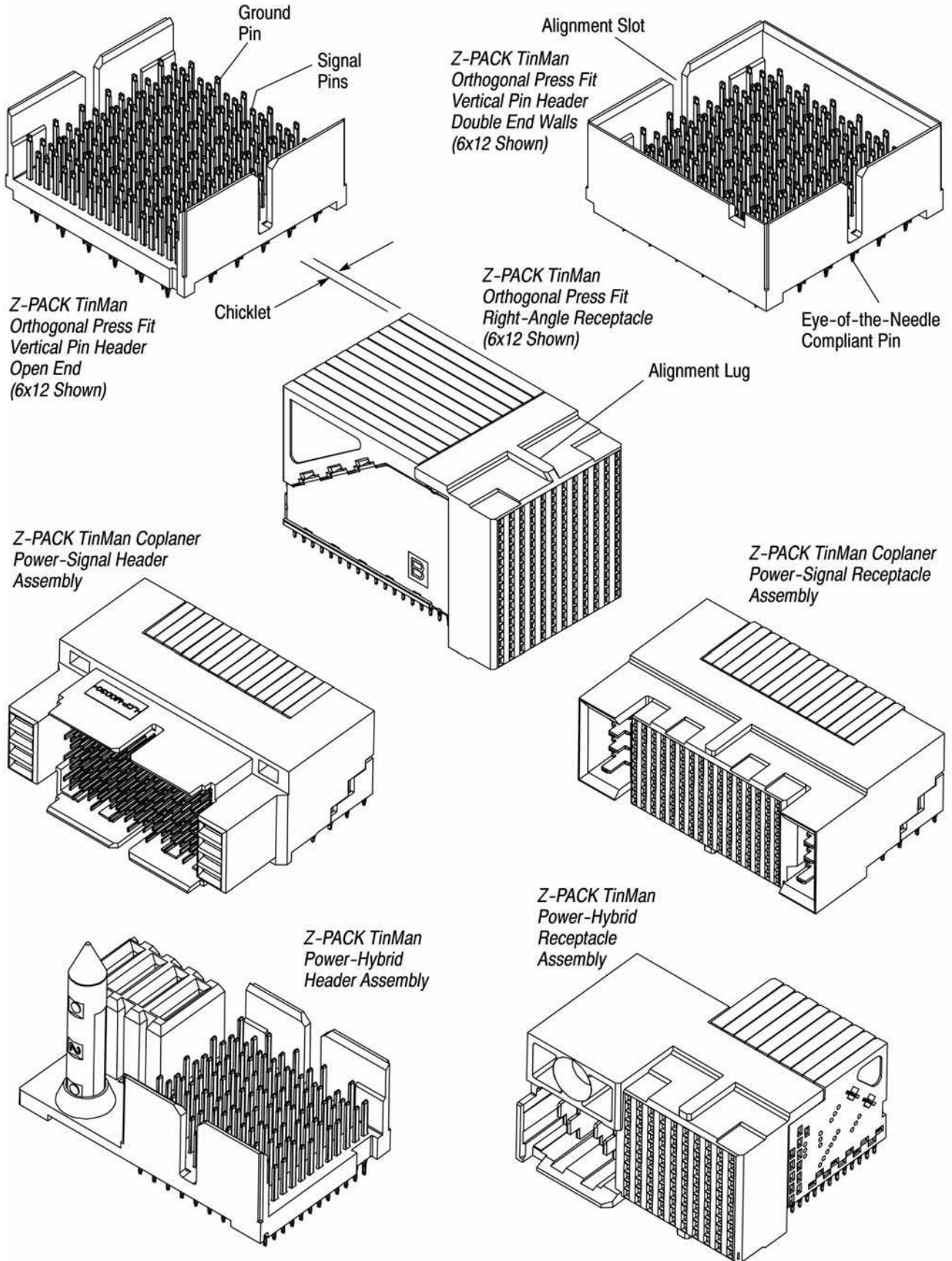

Figure 1 (Cont'd)

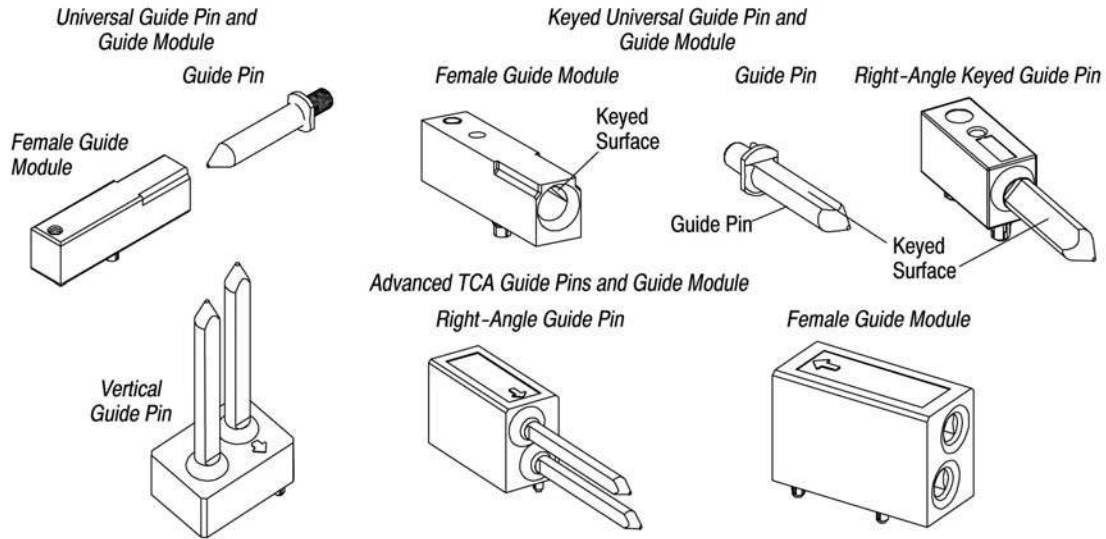

Figure 1 (End)

2. REFERENCE MATERIAL

2.1. Revision Summary

Revisions to this application specification include:

- Updated document to corporate requirements
- New logo

2.2. Customer Assistance

Reference Product Base Part Number 1934269 and Product Code L328 are representative of the Z-PACK TinMan connector system. Use of these numbers will identify the product line and help you to obtain product and tooling information. Such information can be obtained through a local TE representative, by visiting our website at www.te.com, or by calling PRODUCT INFORMATION or the TOOLING ASSISTANCE CENTER at the numbers at the bottom of page 1.

2.3. Drawings

Customer Drawings for specific products are available from the service network. The information contained in Customer Drawings takes priority if there is a conflict with this specification or with any other technical documentation supplied by TE.

2.4. Specifications and Instruction Sheets

Product Specification 108-2303 provides product performance and test results. Instruction sheets 408-10041 and 408-10323 provide information on seating tools and Instruction Sheets 408-10196 and 408-10197 provide information on insertion and extraction tools respectively.

3. REQUIREMENTS

3.1. Storage

The connectors should remain in the shipping containers until ready for use to prevent deformation to the contacts. The connectors should be used on a first in, first out basis to avoid storage contamination that could adversely affect connector performance.

3.2. Product Materials and Selection Criteria

A. Material

All Z-PACK TinMan connector housings and chicklets are molded of high temperature, UL94V-0 rated polyesters.

The header and receptacle contacts are phosphor bronze and plated at the contact interface with gold. All contacts have a nickel underplate and tin plated press-fit leads. Refer to the specific Customer Drawings for additional details.

B. Alignment Features and Guides

The pin headers have alignment slots with a guide-in feature that helps position the pin and receptacle contacts prior to engagement of the circuits. See Figure 1. Figure 2 shows a typical application utilizing a vertical pin header, right-angle receptacle, and universal guide modules.

2A

*Recommended Guide Hardware Spacing Dimensions
(Z-PACK TinMan Receptacle and Open-End Headers with Universal Guide Modules)*

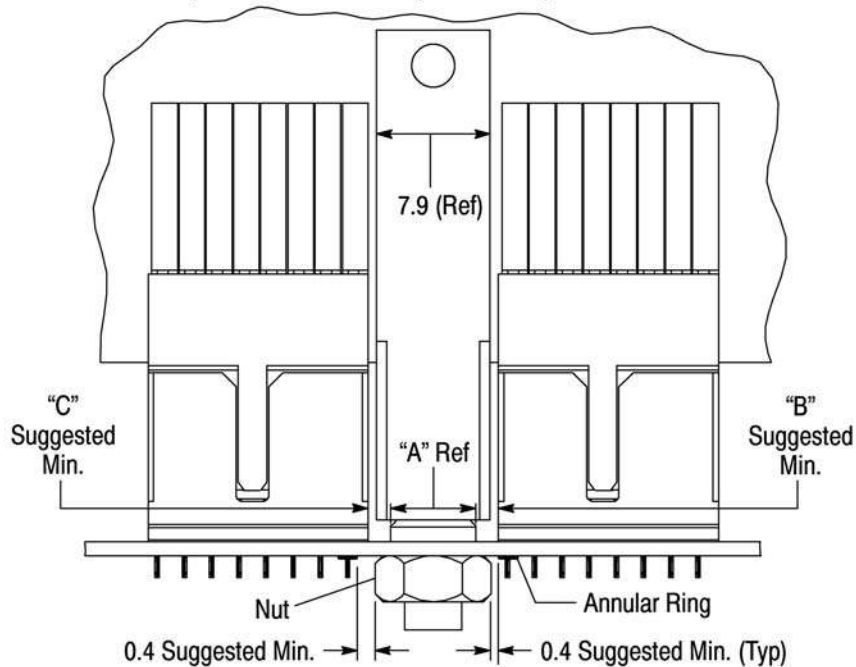

GUIDE MODULE TYPE	DIMENSION		
	A	B	C
UNIVERSAL	7.8	0.6	0.6
KEYED	8.7	0.4	0.4

2B

*Recommended Guide Hardware Spacing Dimensions
(Z-PACK TinMan Receptacle and Double End-Wall Headers with Universal Guide Modules)*

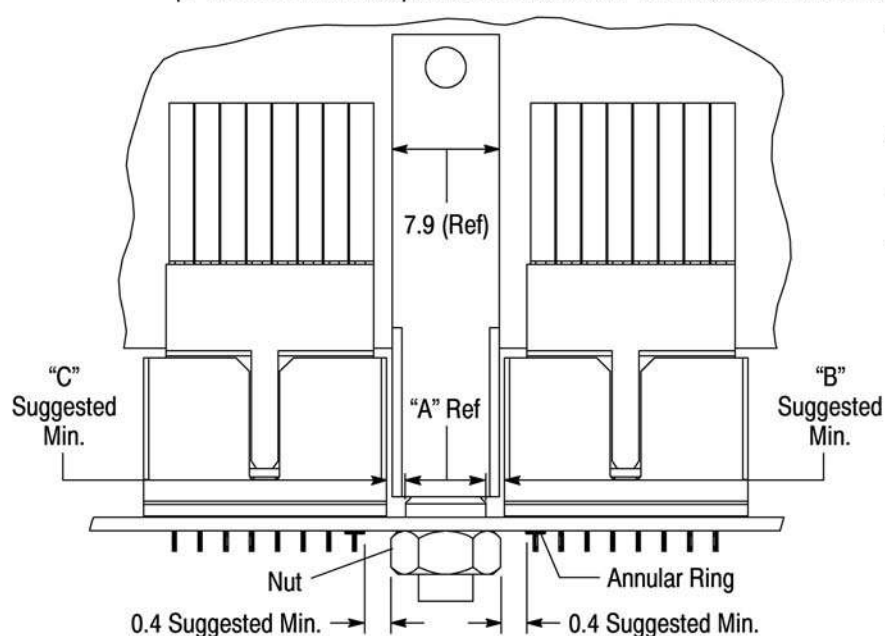

GUIDE MODULE TYPE	DIMENSION		
	A	B	C
UNIVERSAL	7.8	0.4	0.4
KEYED	8.7	0.4	0.4

Figure 2 (Cont'd)

2C

*Recommended Guide Hardware Spacing Dimensions
(Z-PACK TinMan Receptacle and Header with Universal Guide Modules)*

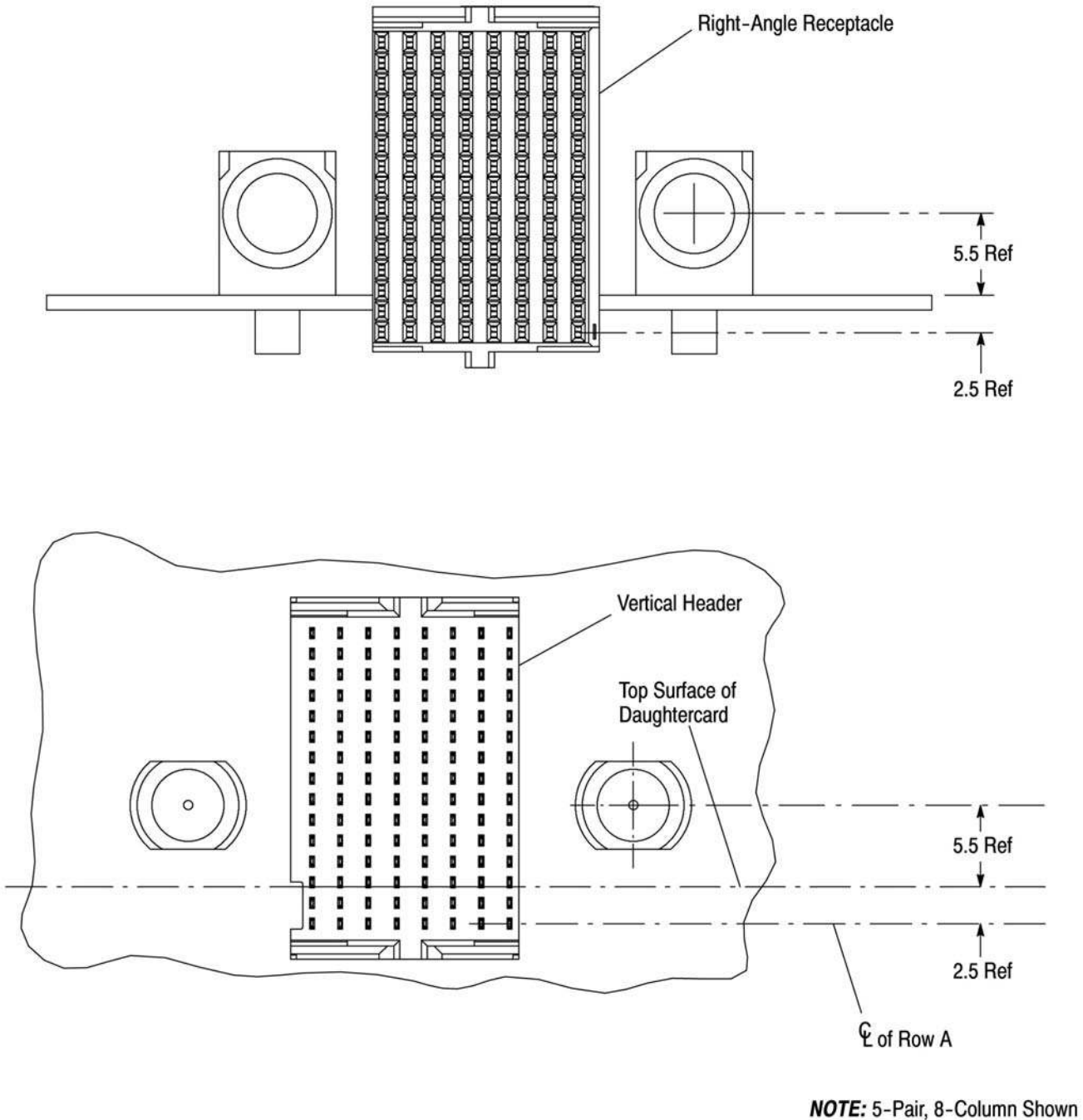
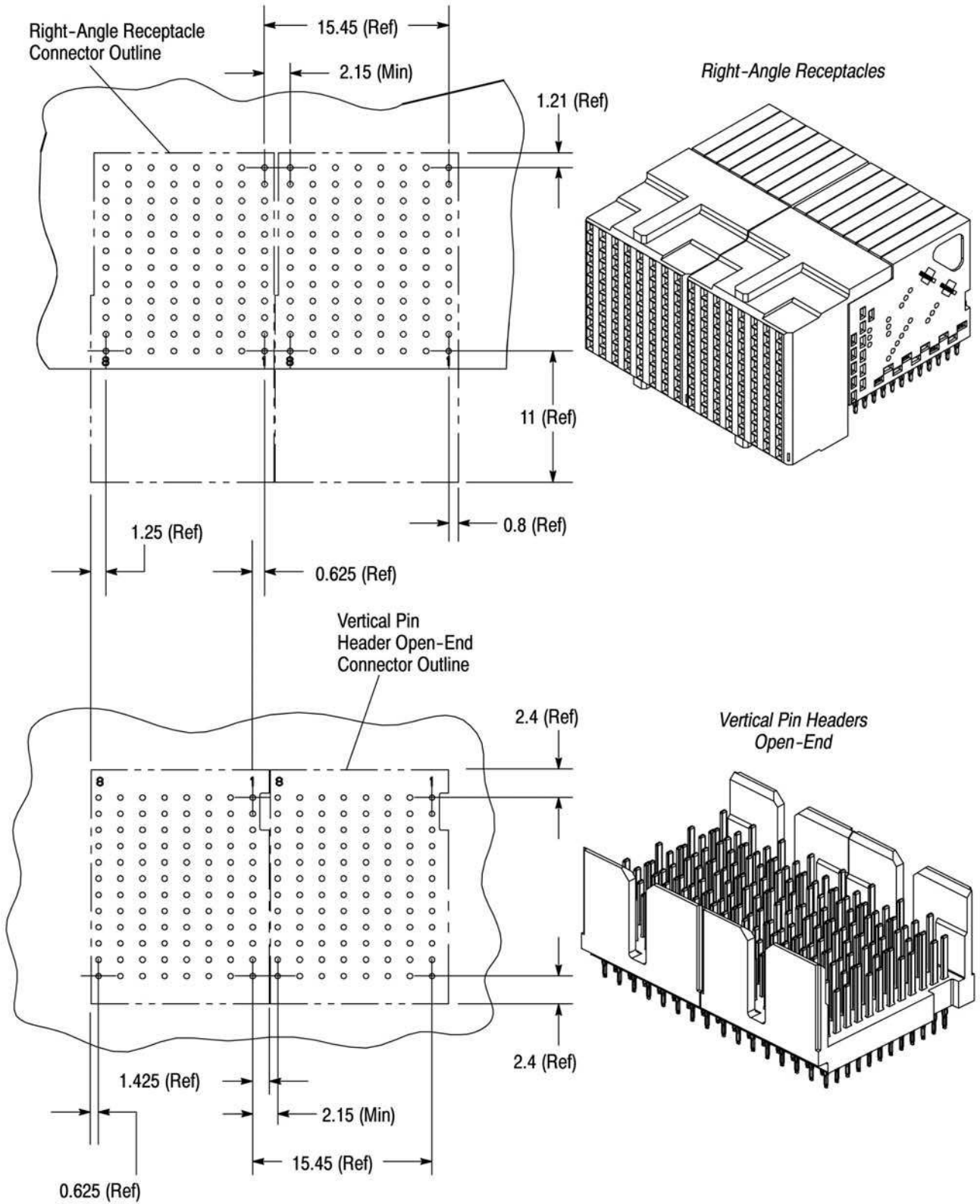

Figure 2 (End)

C. End-to-End Placement

Connectors can be mounted end-to-end within the specified dimensions shown below. When utilizing Z-PACK TinMan connectors with similar connectors or components, contact TE Product Engineering phone numbers at the bottom of page 1 for the recommended spacing. Component side of mother-boards and daughter-boards are shown. See Figure 3A through 3M.

*Right-Angle Receptacle and Vertical Header Open-End
PC Board Layout for End-to-End Placement*



NOTE: 4-Pair Shown
Component Side Shown

Figure 3A

*Right-Angle Receptacle and Vertical Header
Single-End Wall PC Board Layout for End-to-End
Placement*

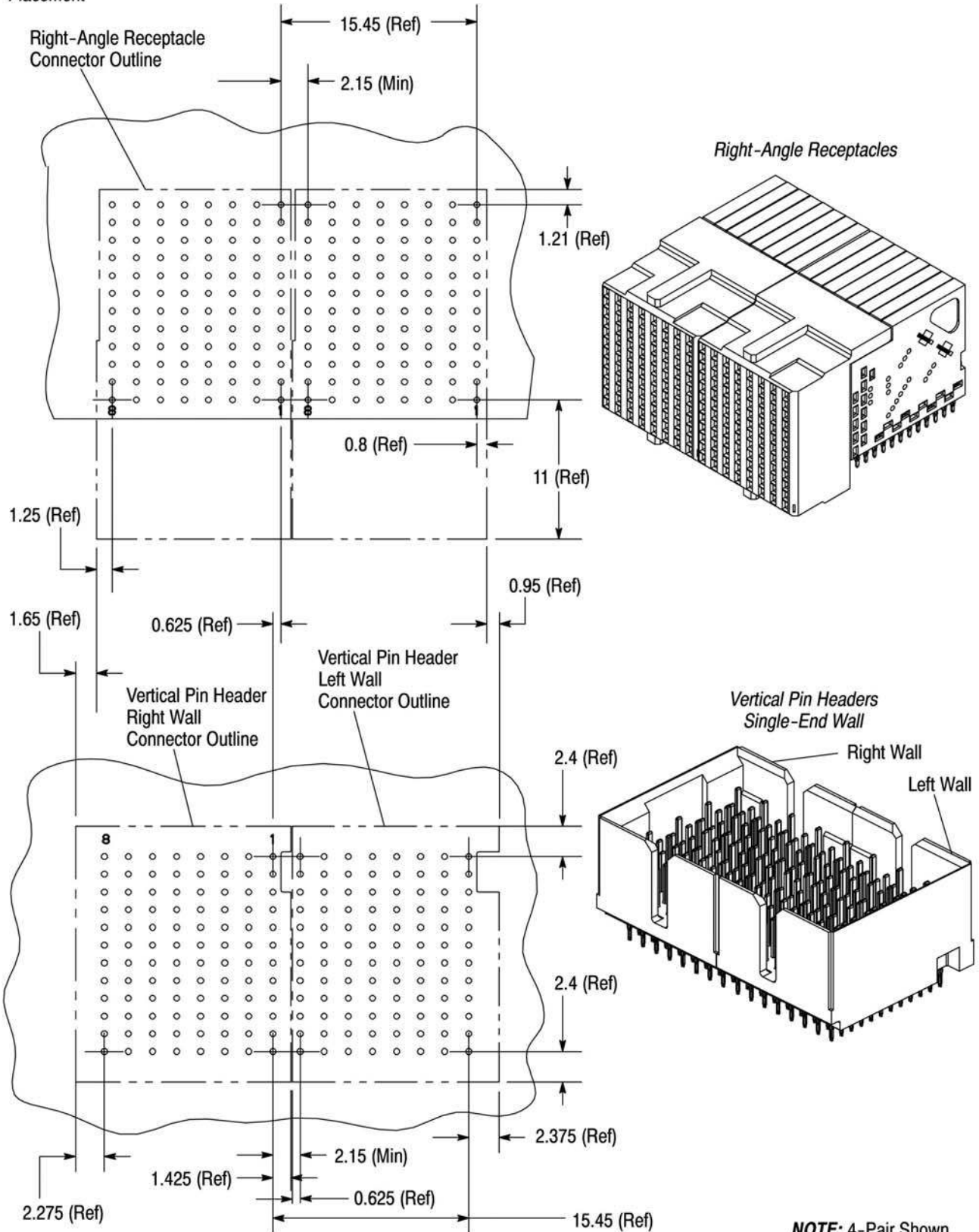

NOTE: 4-Pair Shown
Component Side Shown

Figure 3B

Right-Angle Receptacle and Vertical Header Double-End Walls PC Board Layout for End-to-End Placement

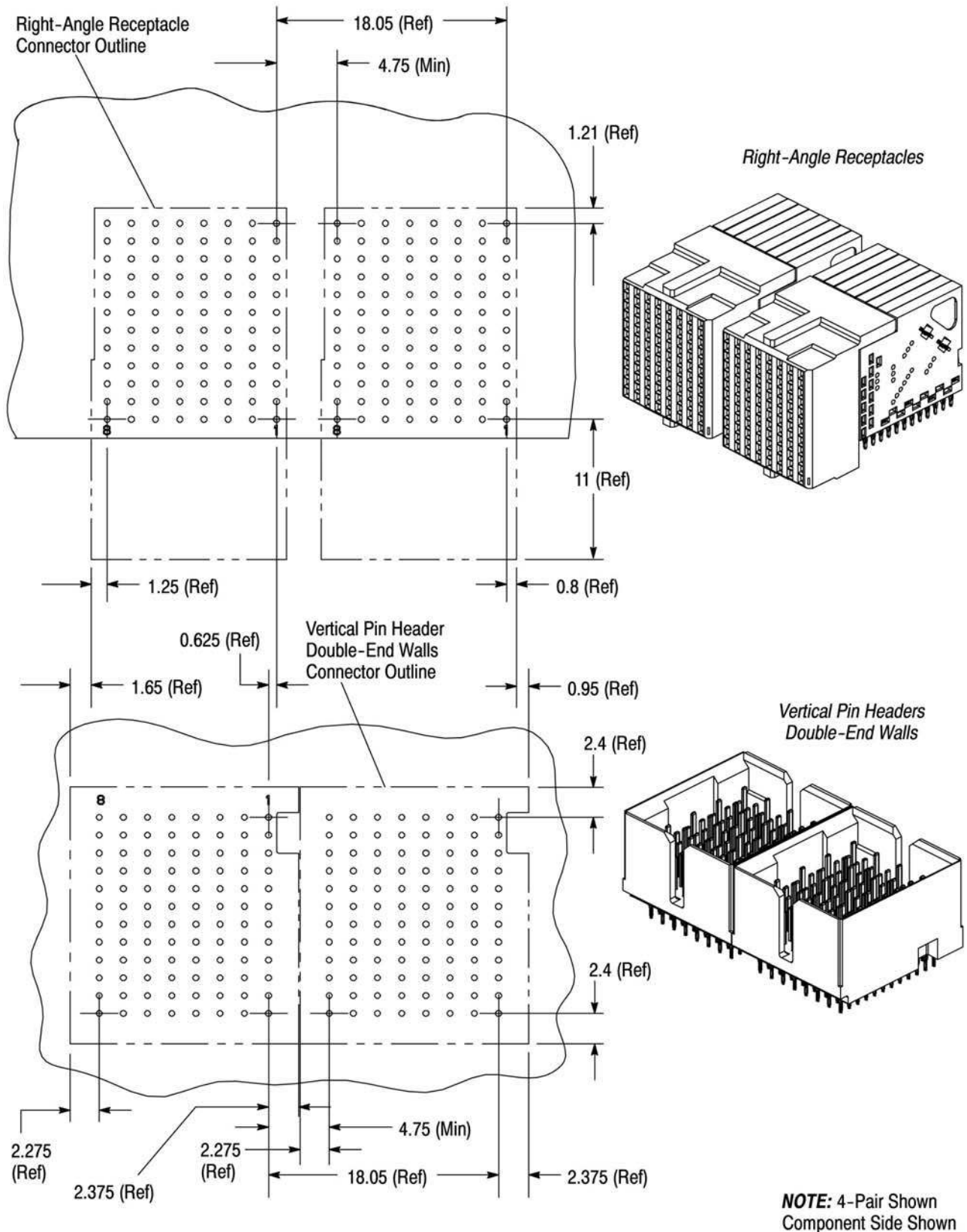
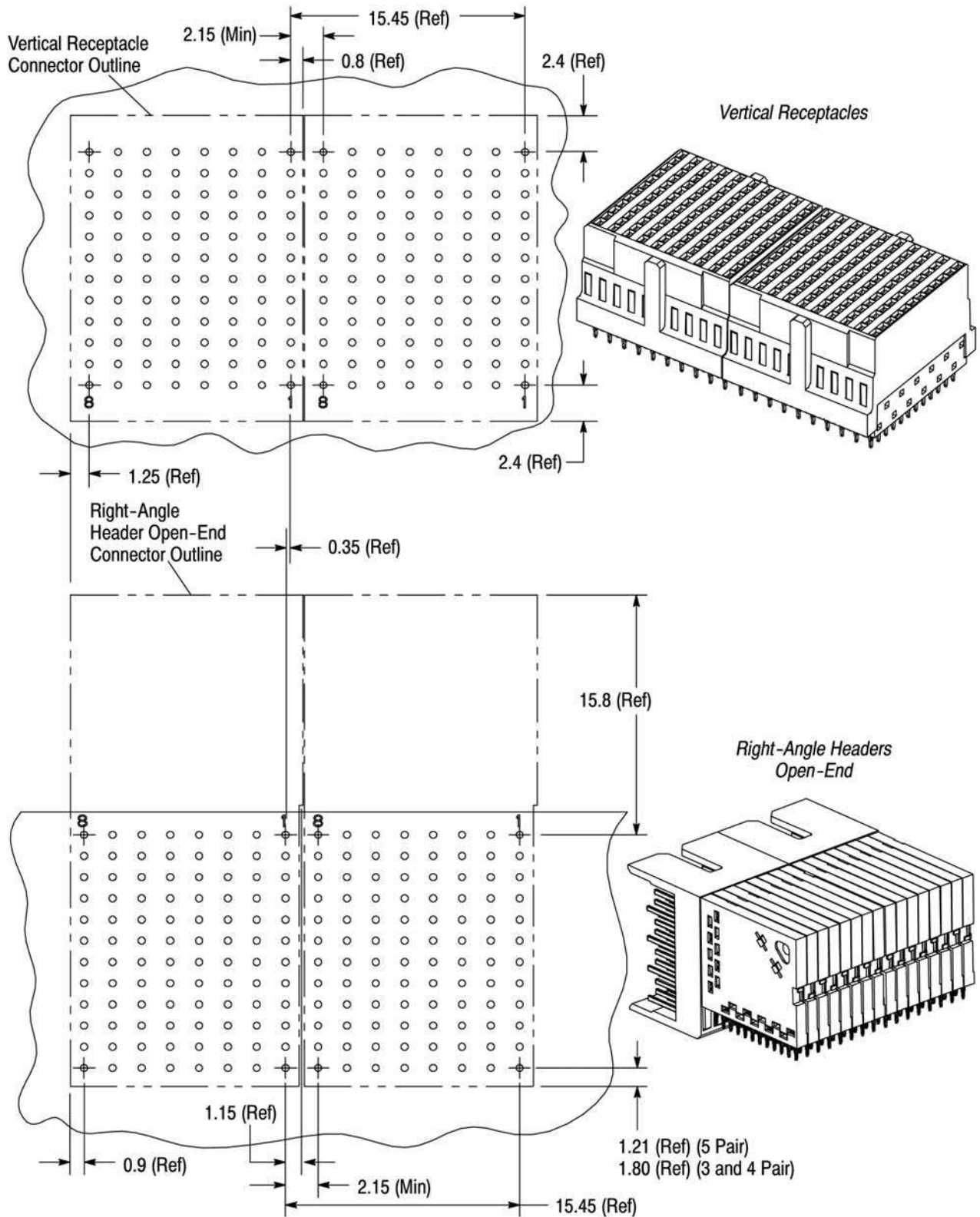

Figure 3C

Vertical Receptacle and Right-Angle Header Open-End
PC Board Layout for End-to-End Placement



NOTE: 4-Pair Shown
Component Side Shown

Figure 3D

Vertical Receptacle and Right-Angle Header Left-End Wall and Right-End Wall PC Board Layout for End-to-End Placement

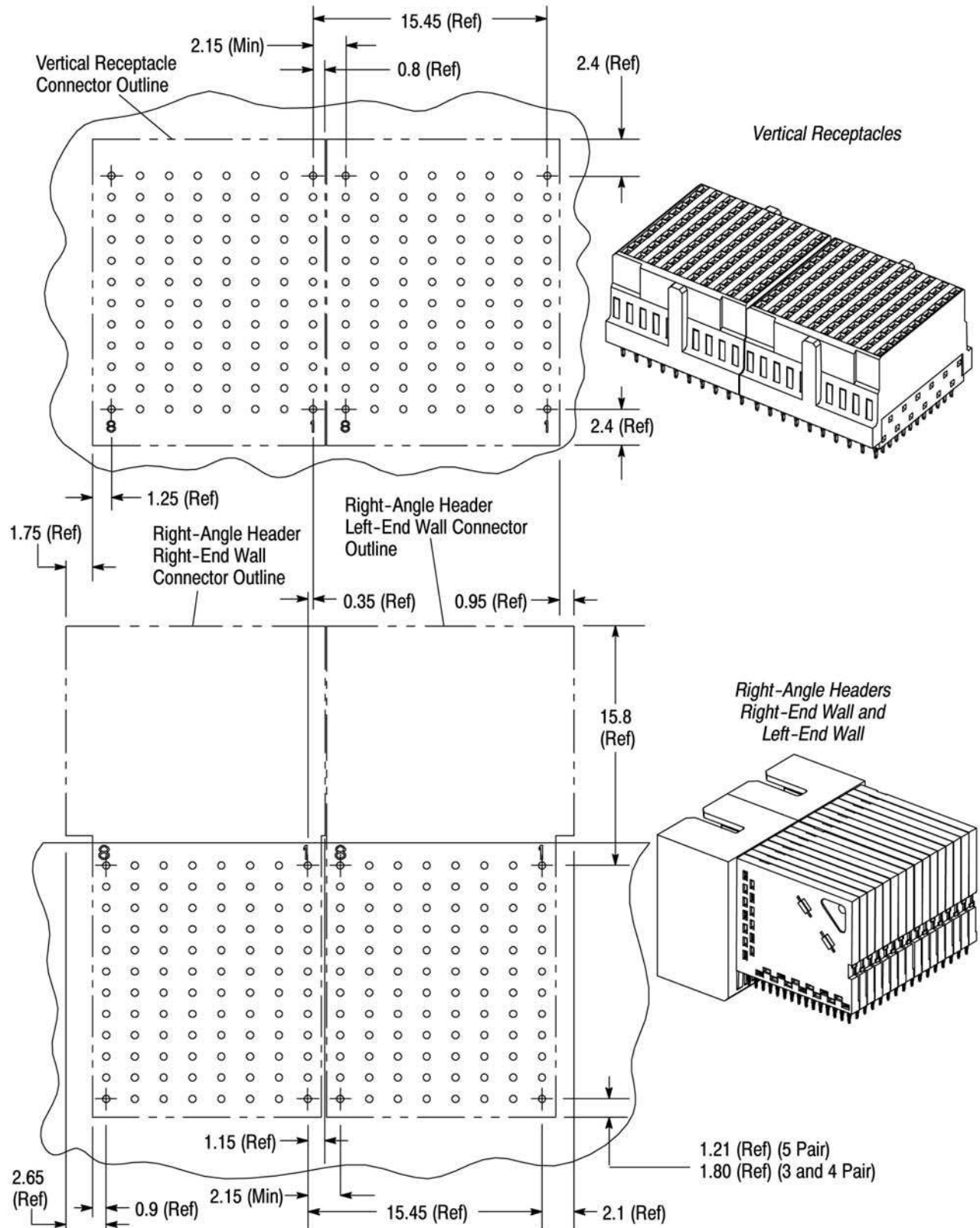

NOTE: 4-Pair Shown
Component Side Shown

Figure 3E

Vertical Receptacle and Right-Angle Header Double-End Walls PC Board Layout for End-to-End Placement

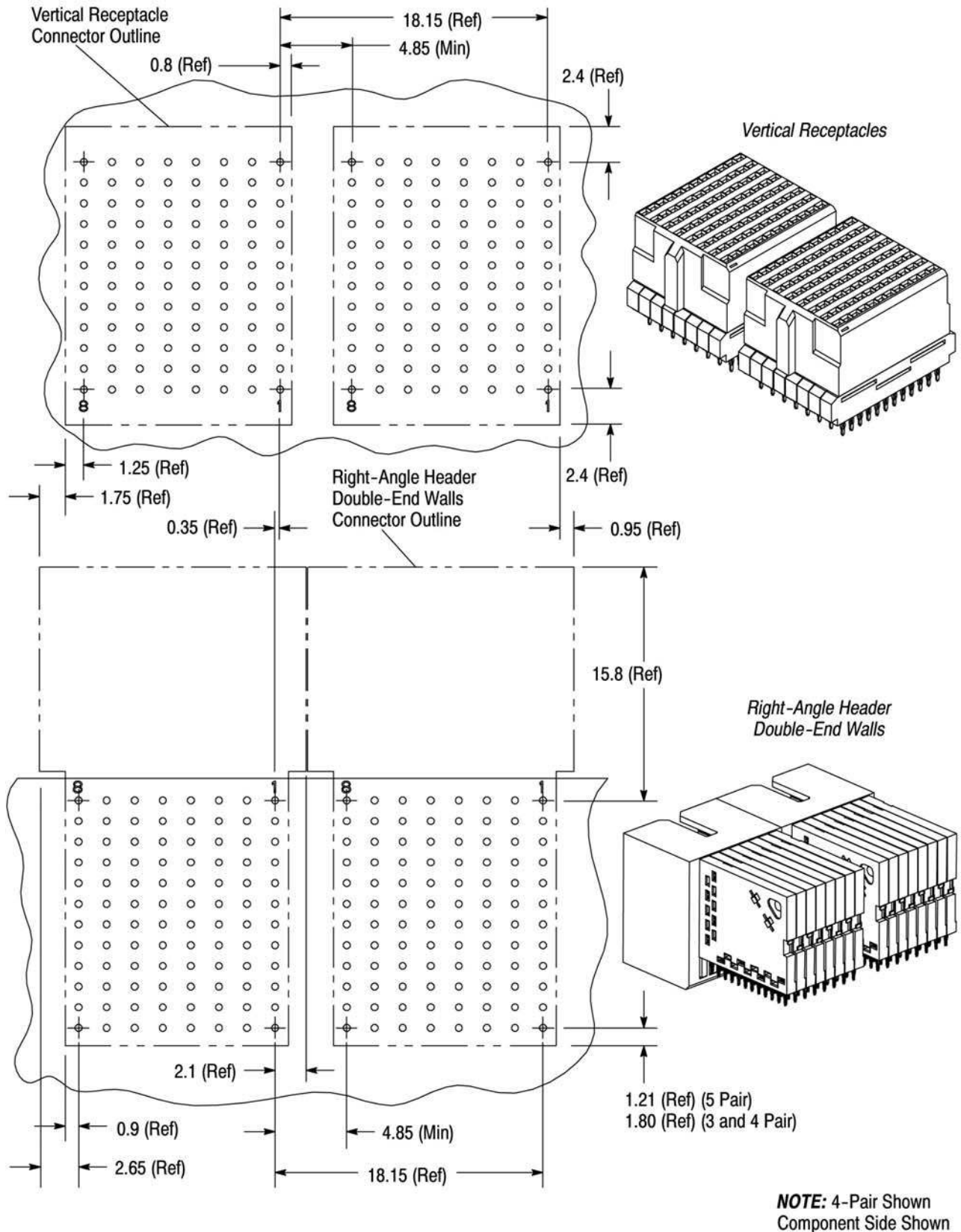

Figure 3F

*Right-Angle Receptacle and Right-Angle Header
Open-End PC Board Layout for End-to-End Placement*

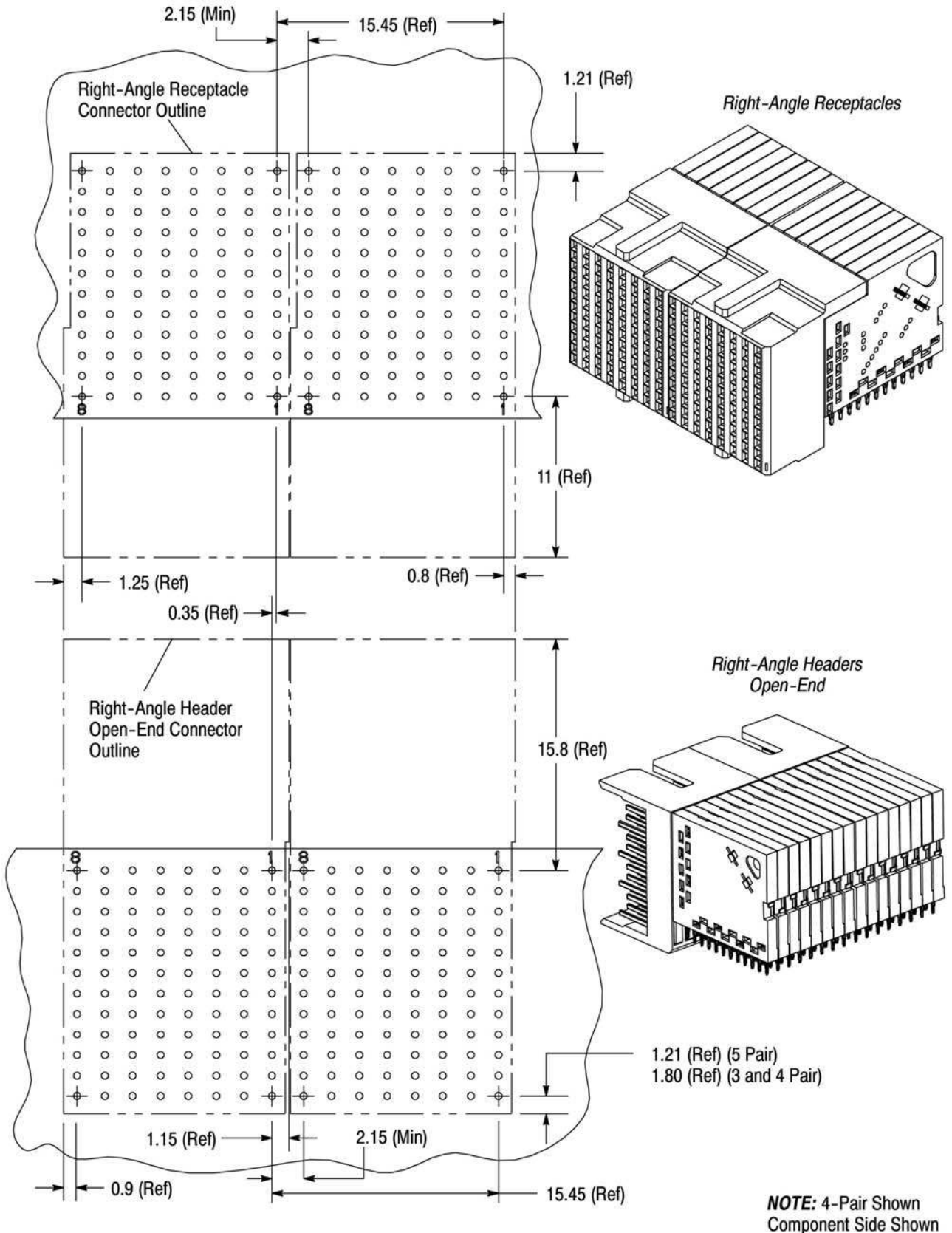

Figure 3G

Right-Angle Receptacle and Right-Angle Header Left-End Wall and Right-End Wall PC Board Layout for End-to-End Placement

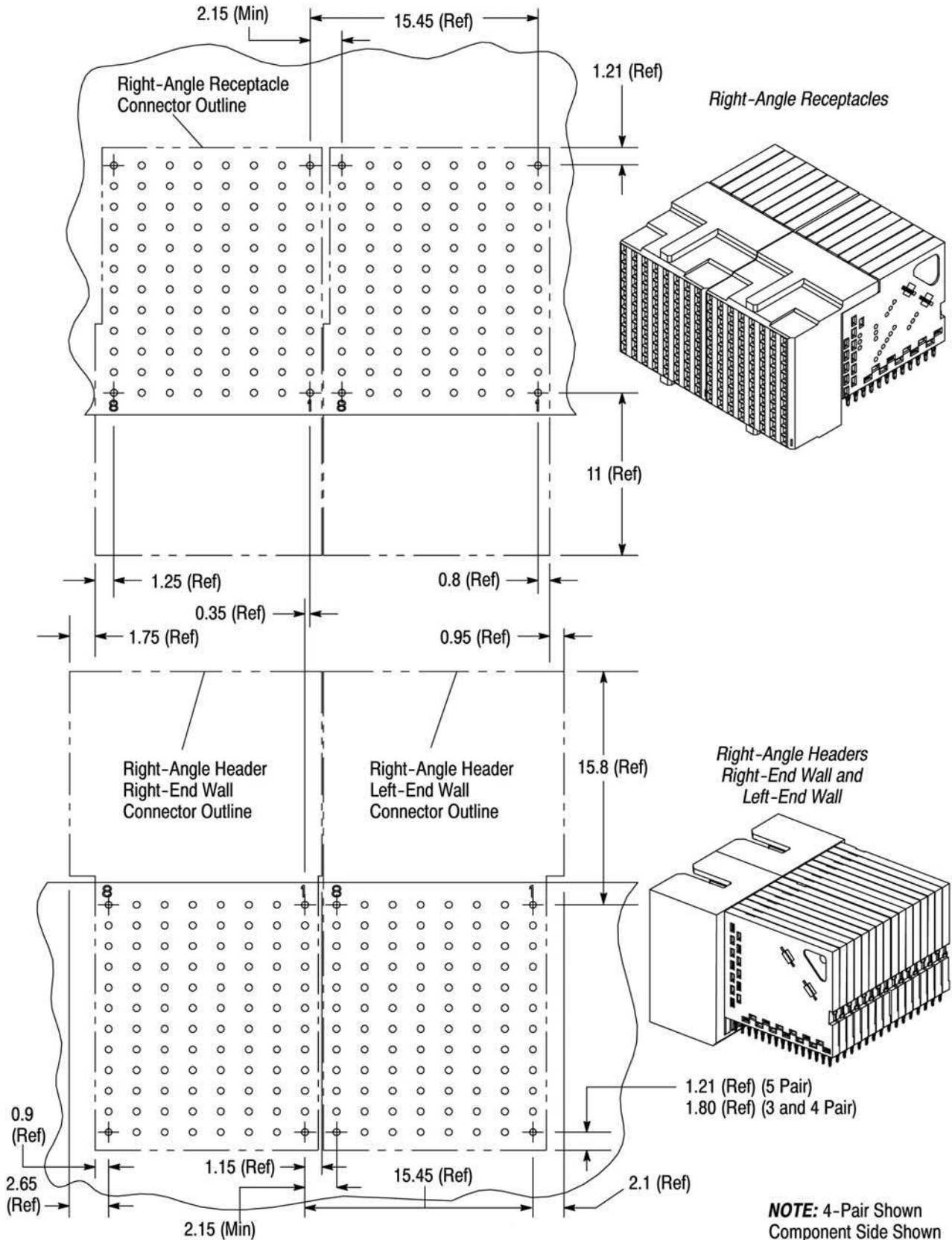

Figure 3H

Right-Angle Receptacle and Right-Angle Header Double-End Walls PC Board Layout for End-to-End Placement

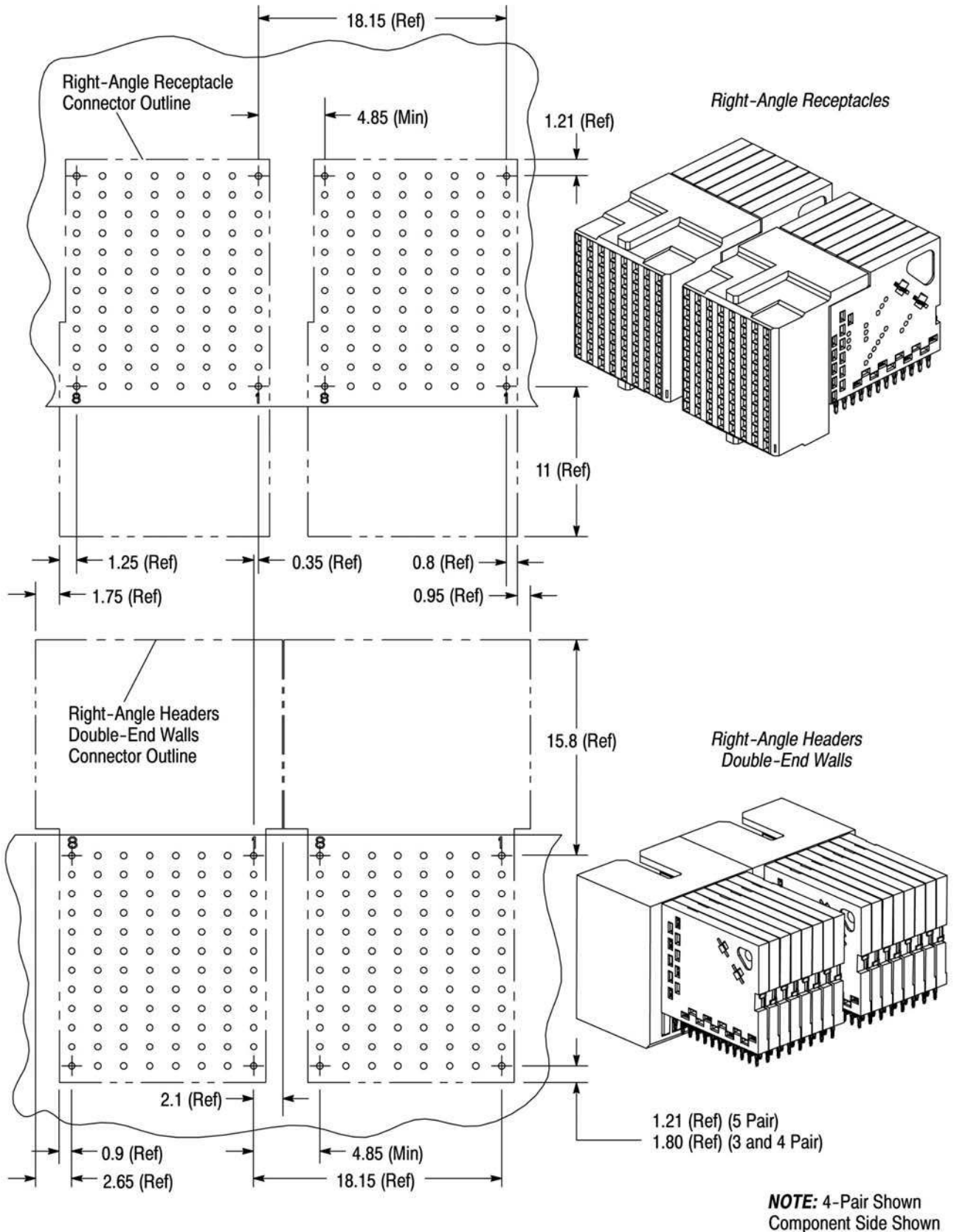
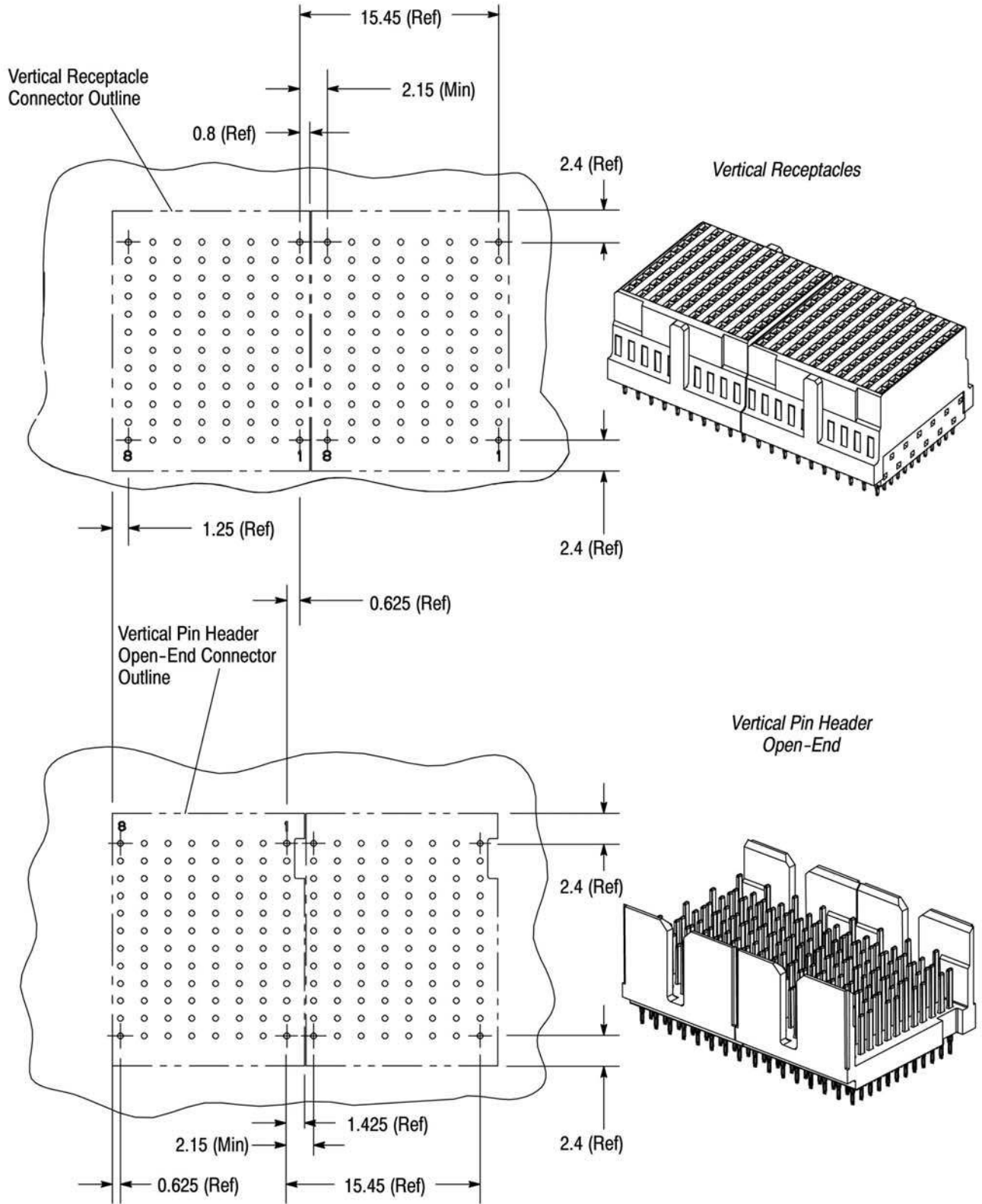

Figure 31

*Vertical Receptacle and Vertical Header Open-End
PC Board Layout for End-to-End Placement*



NOTE: 4-Pair Shown
Component Side Shown

Figure 3J

Vertical Receptacle and Vertical Header Single-End Wall PC Board Layout for End-to-End Placement

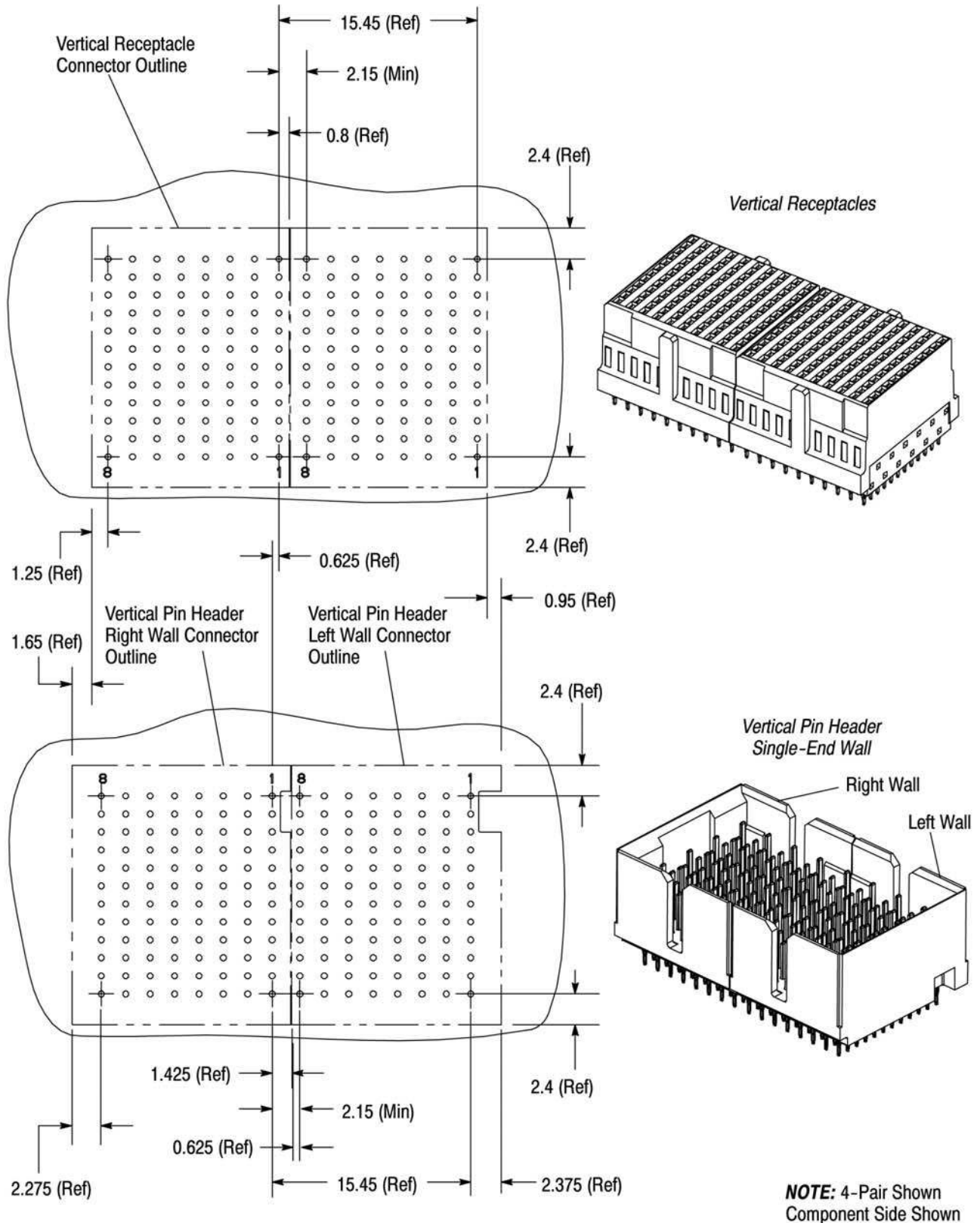

Figure 3K

Vertical Receptacle and Vertical Header Double-End Walls PC Board Layout for End-to-End Placement

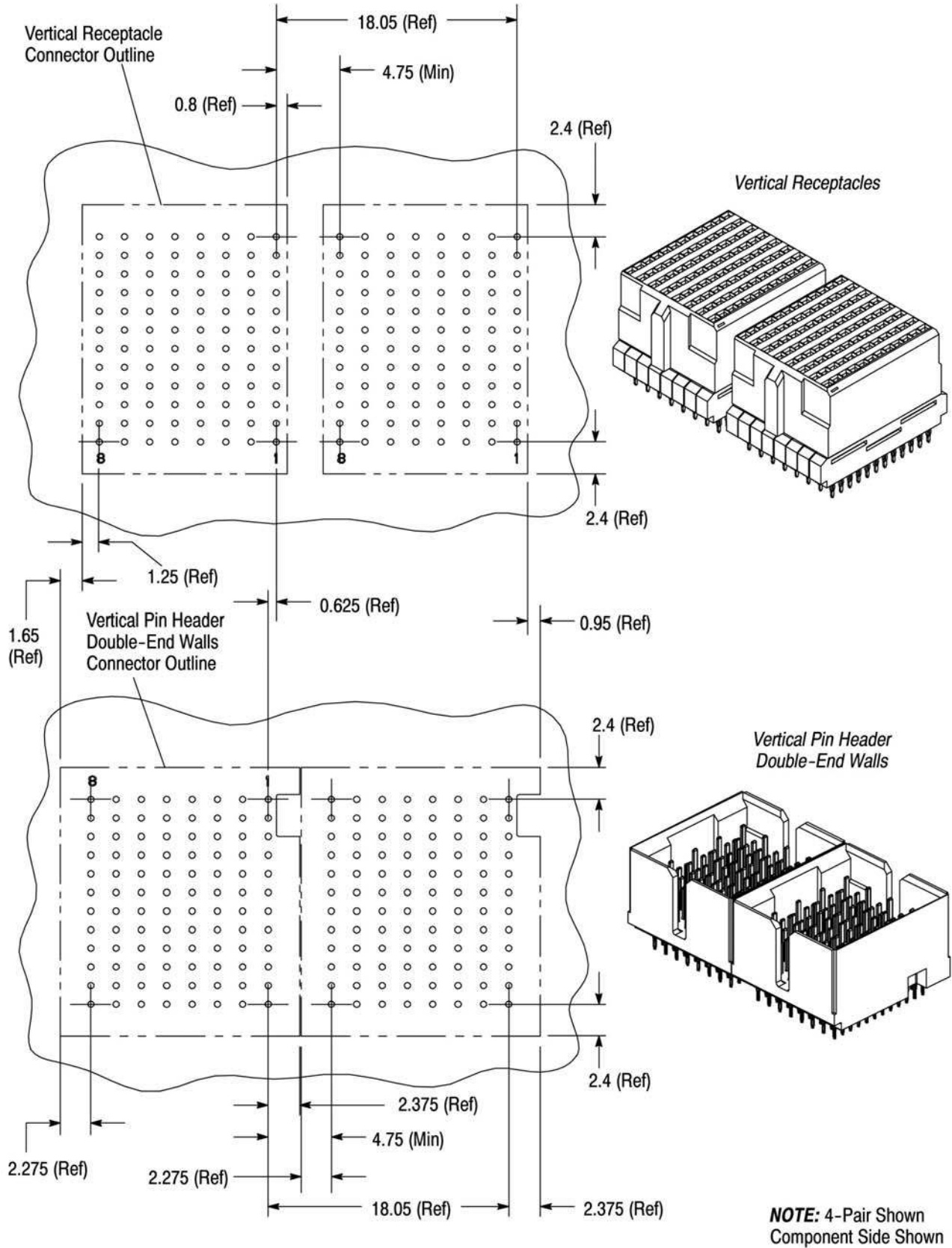
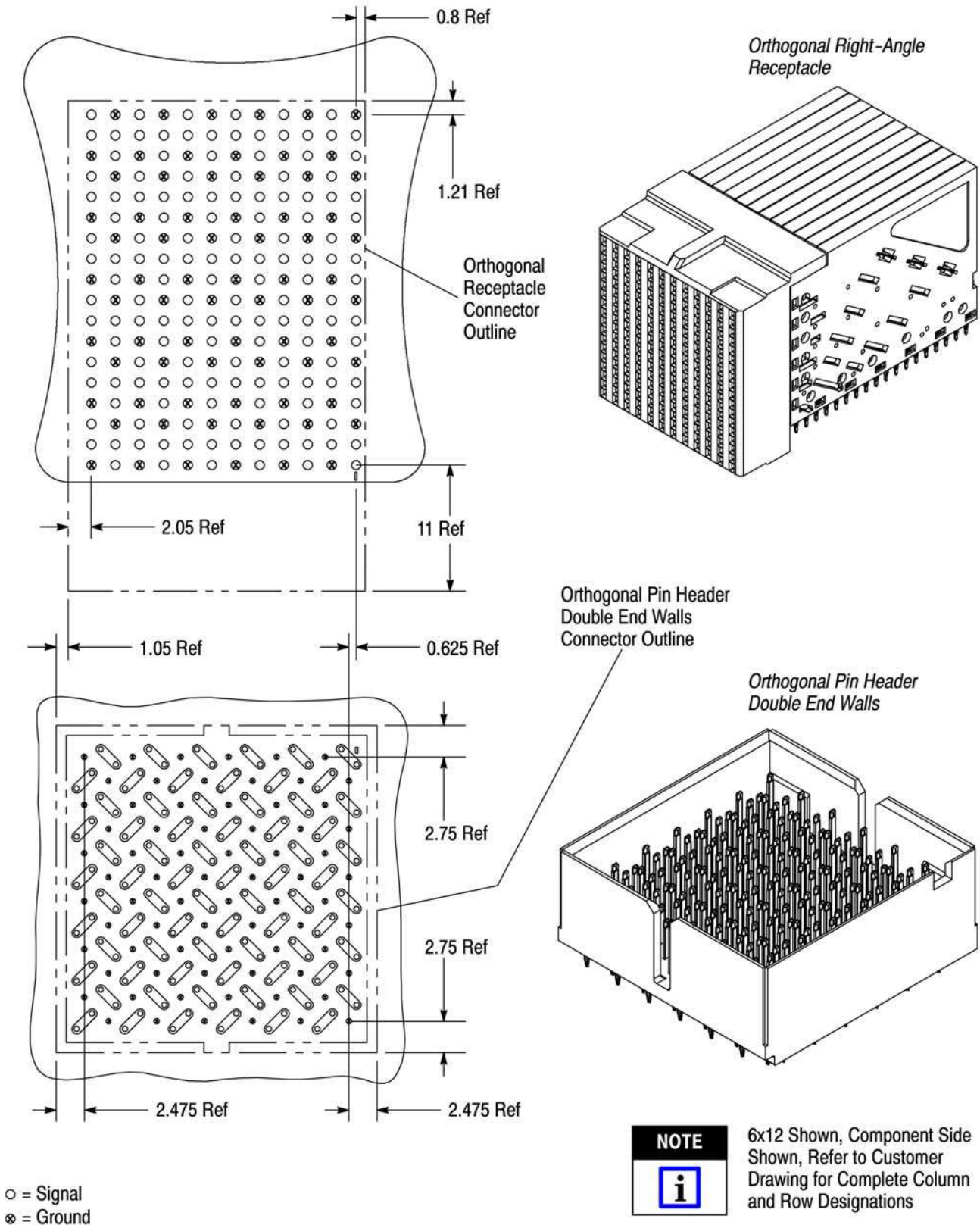

Figure 3L

Z-PACK TinMan Orthogonal Receptacle and Header Double End Walls PC Board Layout



NOTE 6x12 Shown, Component Side Shown, Refer to Customer Drawing for Complete Column and Row Designations

Figure 3M

D. Sizes

Length of pins are shown in Figure 4.

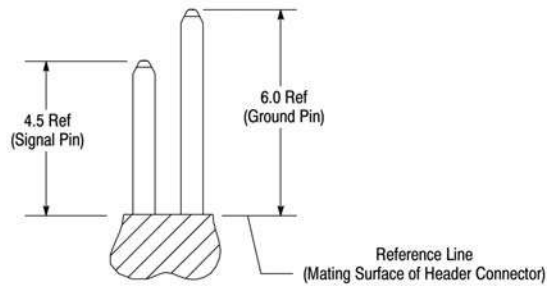

NOTE: Contact Tyco Electronics Product Engineering for Other Pin Lengths

Figure 4

3.3. Alignment

Proper alignment is essential to ensure full engagement of mating connectors, and to ensure that contacts are not bent or otherwise damaged during mating and unmating. For tolerance limitations, see Figure 5.

NOTE: 4-Pair Vertical Pin Header and Right-Angle Receptacle Shown for Reference

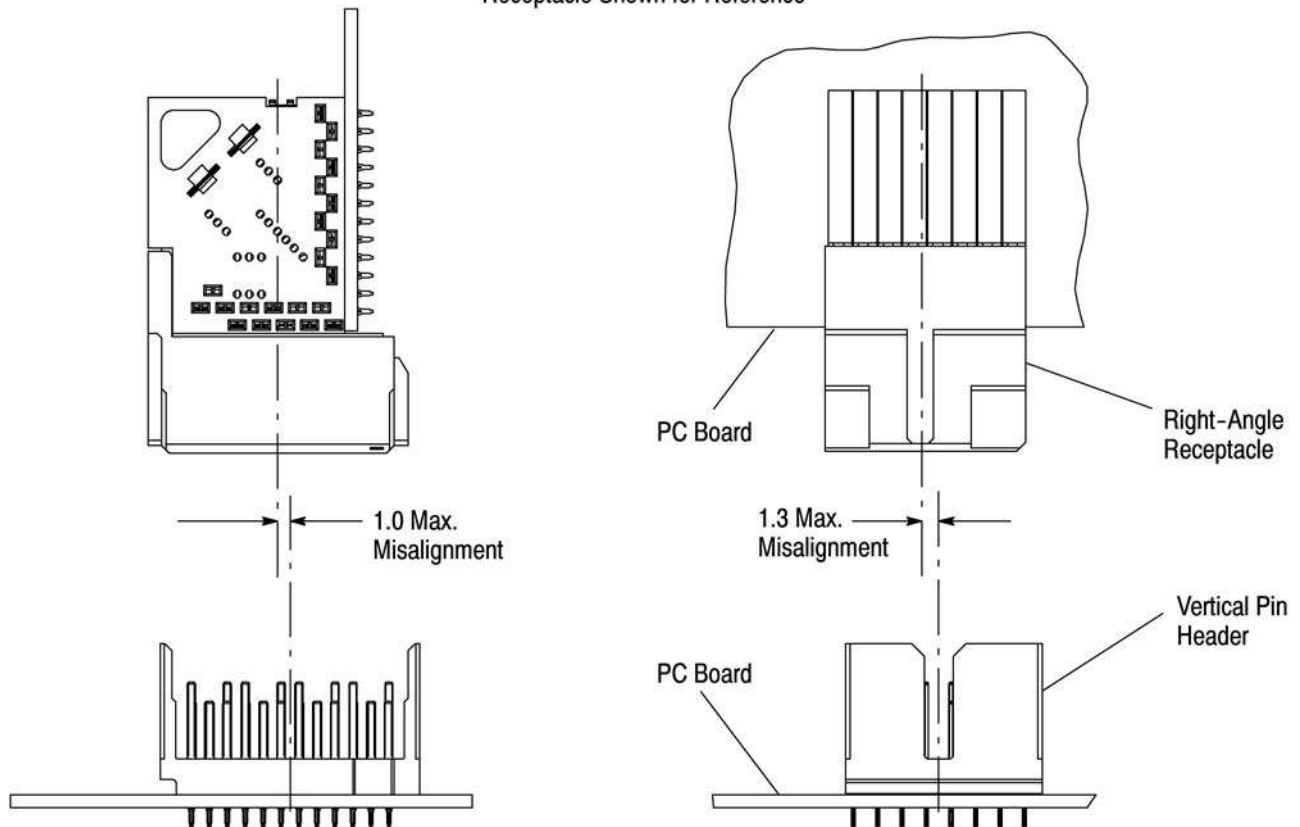

Figure 5 (Cont'd)

NOTE: 4-Pair Shown

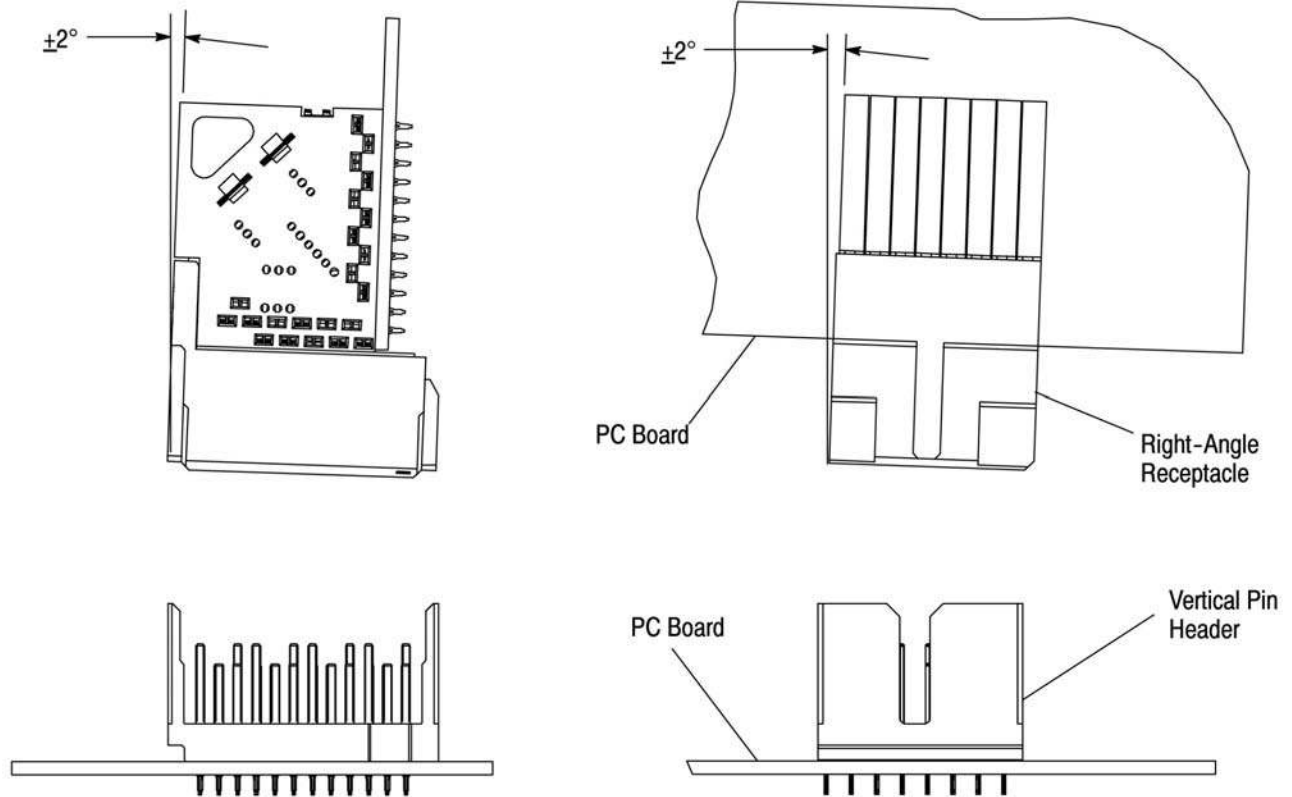

Figure 5 (End)

3.4. Mating Sequences and Wipe Length

The Z-PACK TinMan connector system has two basic levels of sequencing during mating. The order of mating is as follows: Ground Pin and Signal Pin. Figure 6 (Figure 6A - Standard Sex; Figure 6B - Reverse Sex) shows the relative distances between sequencing events as a function of the distance between the surface of the backplane and the centerline of Row A of the daughtercard connector.

Full mating of connectors is necessary to ensure a good connection and to obtain the maximum signal transmission performance. The dimension shown for the fully mated condition from the surface of the backplane, and the first row of contacts in the daughtercard connector is recommended. Refer to Figure 6.

Connector wipe dimensions are shown in Figure 6. Wipe lengths are calculated by subtracting the fully mated connector condition from the reliable mating point data (Dim A in table) as shown in Figure 6.

NOTE: 4-Pair Shown

Standard Sex-Mating Sequences and Wipe Lengths

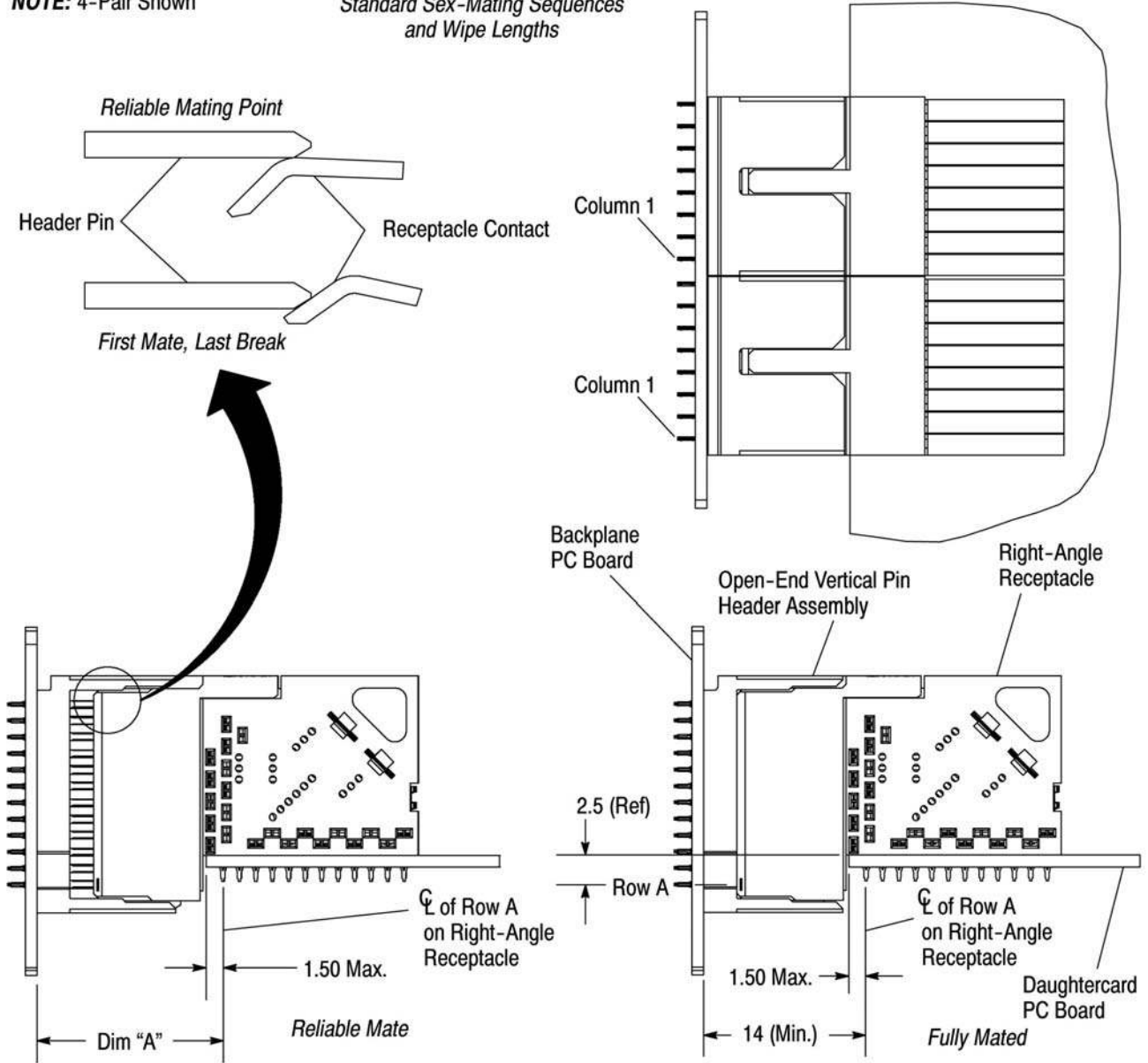

NOTE: The first mate, last break sequencing point is the first and last instance in a mating cycle where the pin comes in contact with the beam, but has not deflected the beam. The reliable mating point is the first and last instance in a mating cycle where the pin has completely deflected the beam, and the beam is supplying full normal force to the pin.

PIN TYPE	DIMENSION "A"		FULLY MATED WIPE LENGTH
	RELIABLE MATE	FIRST MATE, LAST BREAK	
Plastic Alignment, First Mate	N/A	22.8	N/A
Ground Pin	17.94	18.63	3.94
Signal Pin	16.44	17.13	2.44

NOTE: All dimensions are calculated using nominal connector conditions. Connectors are assumed to be seated flush with the pc board.

Figure 6A

NOTE: 4-Pair Shown

Reverse Sex-Mating Sequences and Wipe Lengths

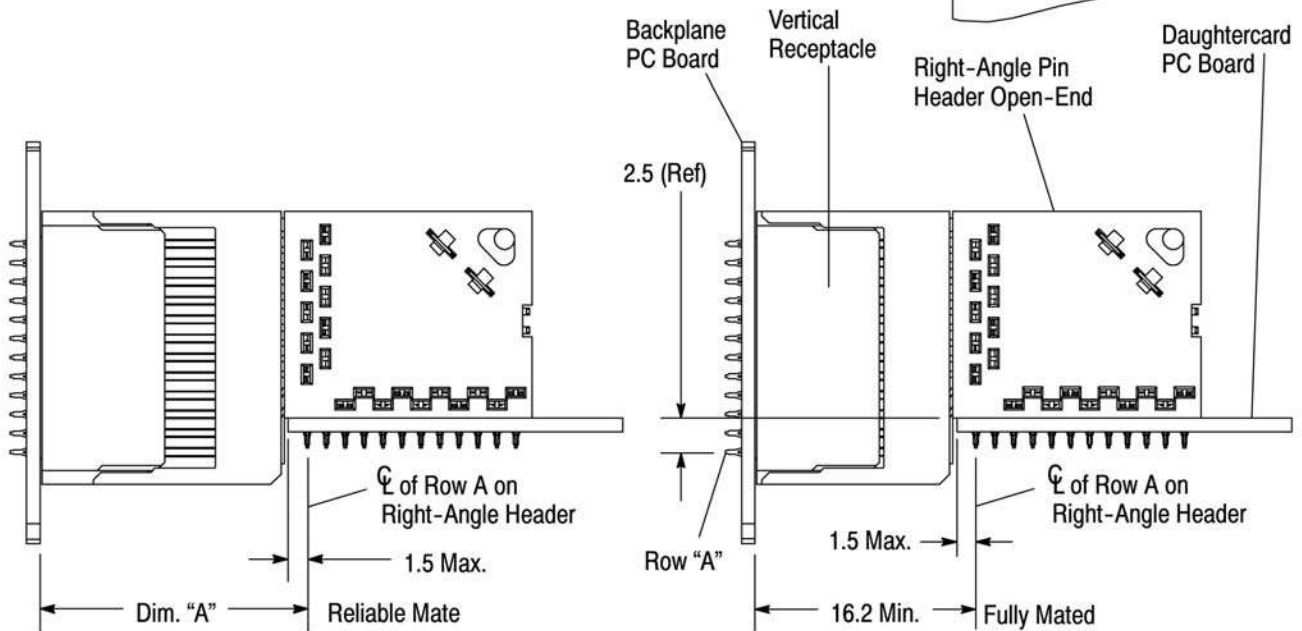
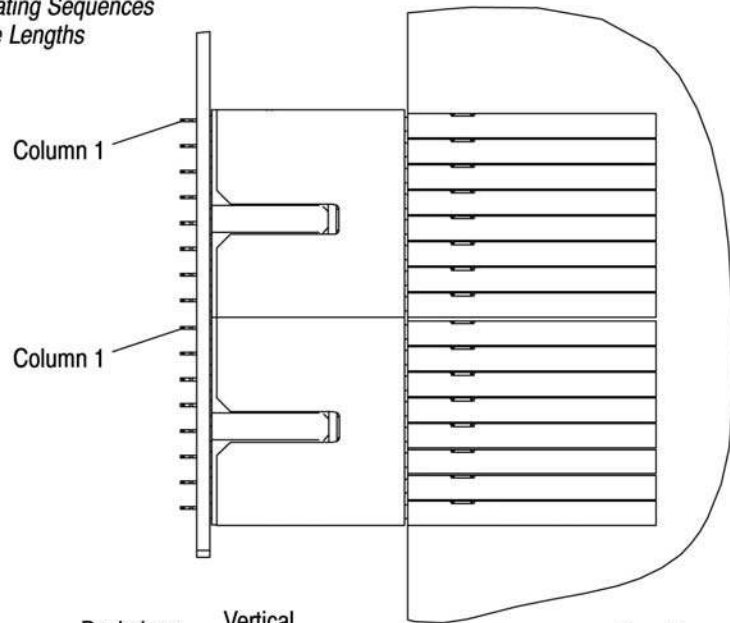
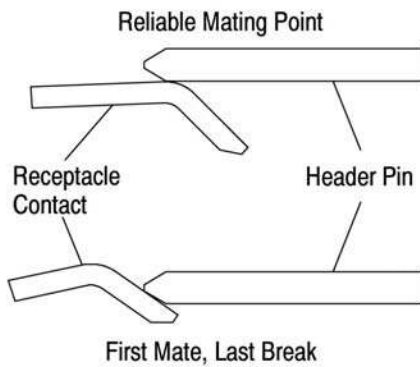

NOTE: The first mate, last break sequencing point is the first and last instance in a mating cycle where the pin comes in contact with the beam, but has not deflected the beam. The reliable mating point is the first and last instance in a mating cycle where the pin has completely deflected the beam, and the beam is supplying full normal force to the pin.

PIN TYPE	DIMENSION "A"		FULLY MATED WIPE LENGTH
	RELIABLE MATE	FIRST MATE, LAST BREAK	
Plastic Alignment, First Mate	N/A	25	N/A
Ground Pin	20.24	20.93	4.04
Signal Pin	18.74	19.43	2.54

NOTE: All dimensions are calculated using nominal connector conditions. Connectors are assumed to be seated flush with the pc board.

Figure 6B

3.5. Mid-Plane Applications

A. For mid-plane applications using vertical headers and right-angle receptacles, standard and reverse loaded header and receptacle connectors must be used.

NOTE *A different plating option may be required. Contact the Product Information number at the bottom of page 1 for additional information. Refer to Figure 7 for options.*

7A

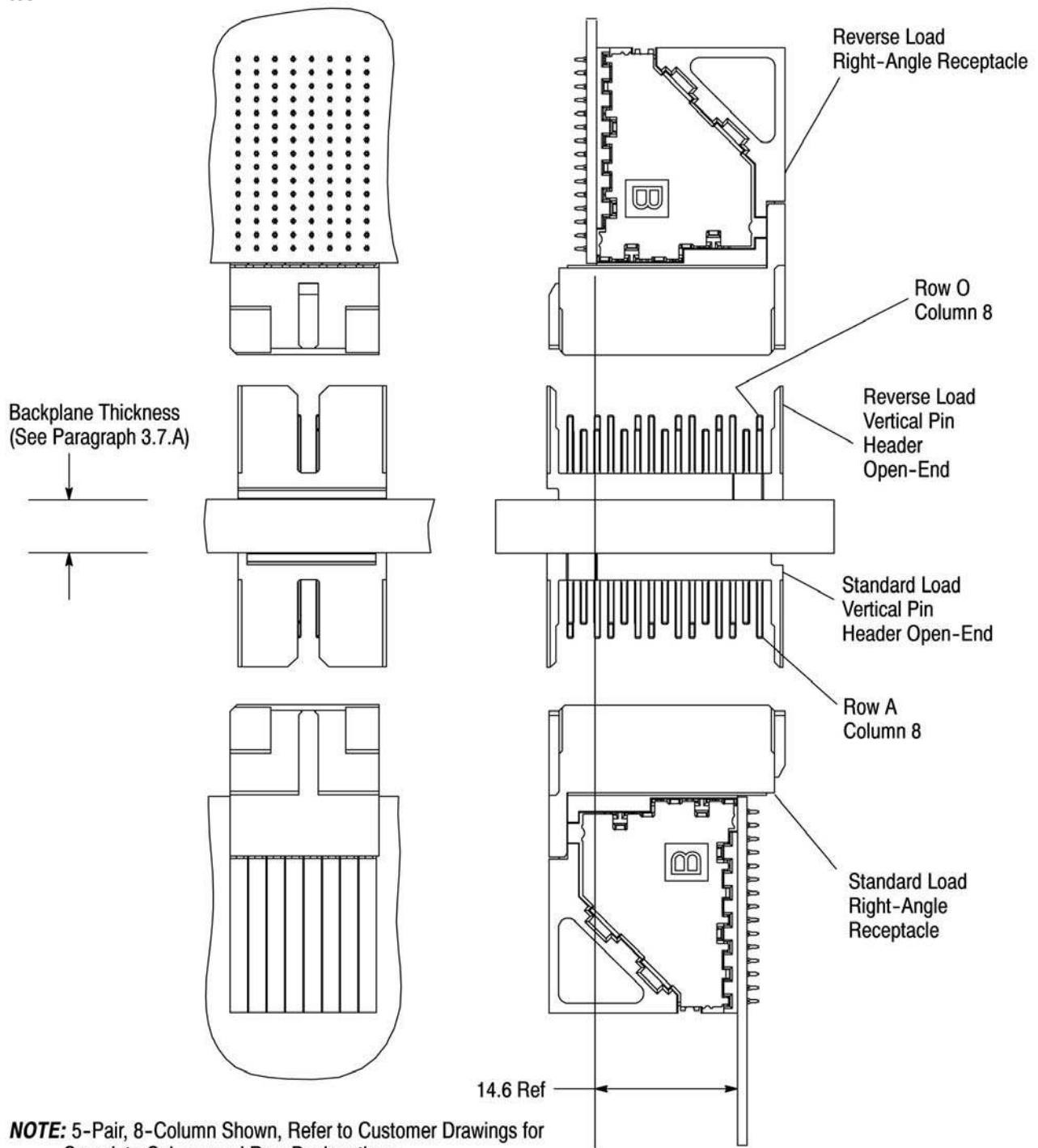

NOTE: 5-Pair, 8-Column Shown, Refer to Customer Drawings for Complete Column and Row Designations

Figure 7 (Cont'd)

7B

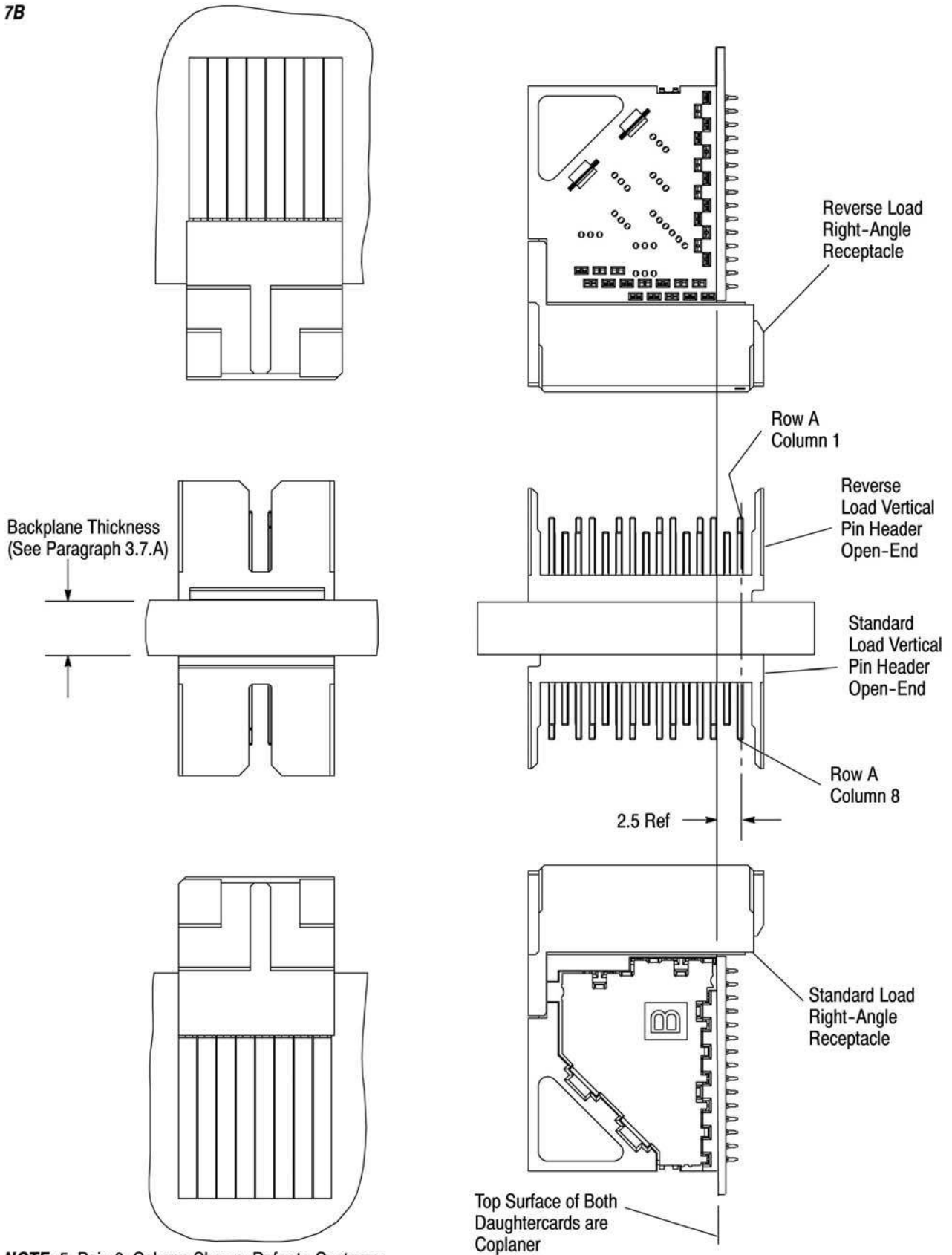

NOTE: 5-Pair, 8-Column Shown, Refer to Customer Drawings for Complete Column and Row Designations

Figure 7 (End)

B. For mid-plane application options using Z-PACK TinMan orthogonal vertical headers and right-angle receptacles, refer to Figure 8.

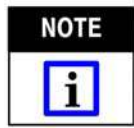

When using 6x6 connectors in this configuration the receptacle shown requires a different part number than the other receptacles. Contact the Product Information number at the bottom of page 1 for additional information.

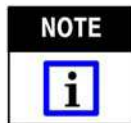
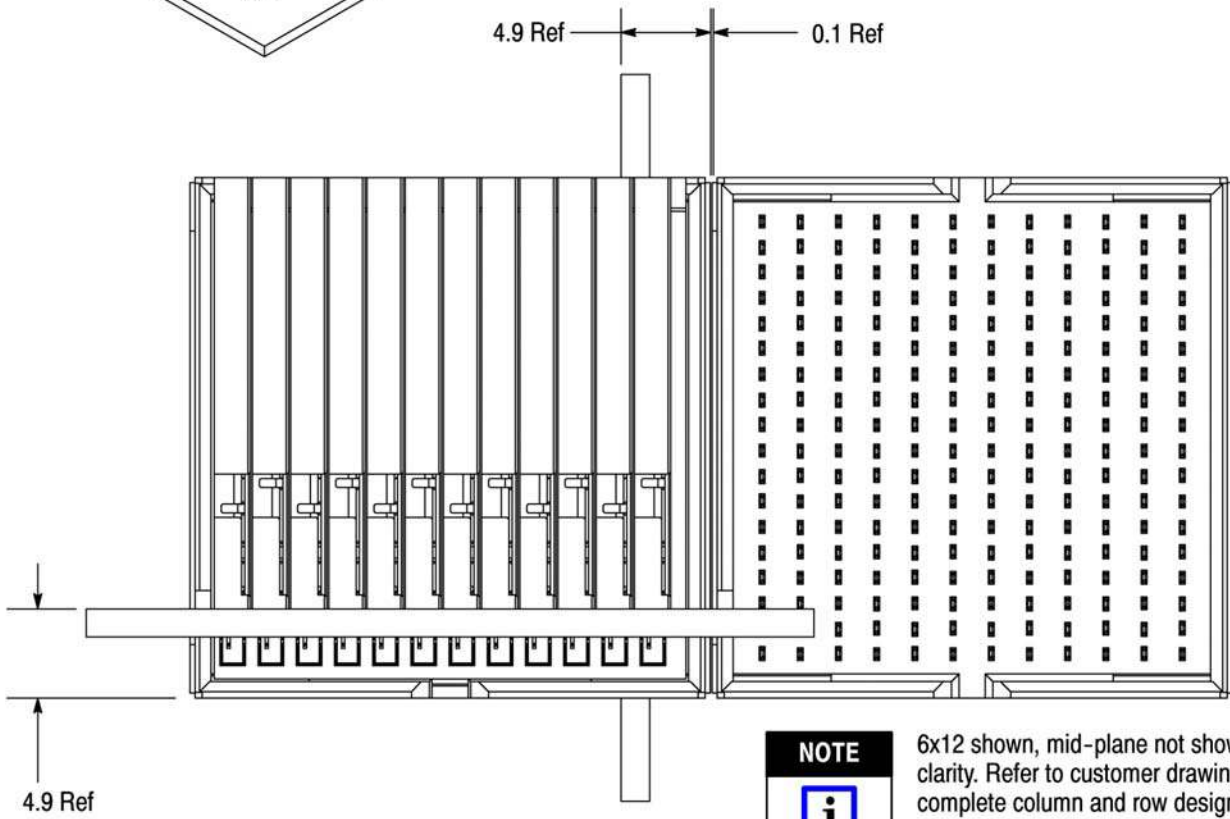
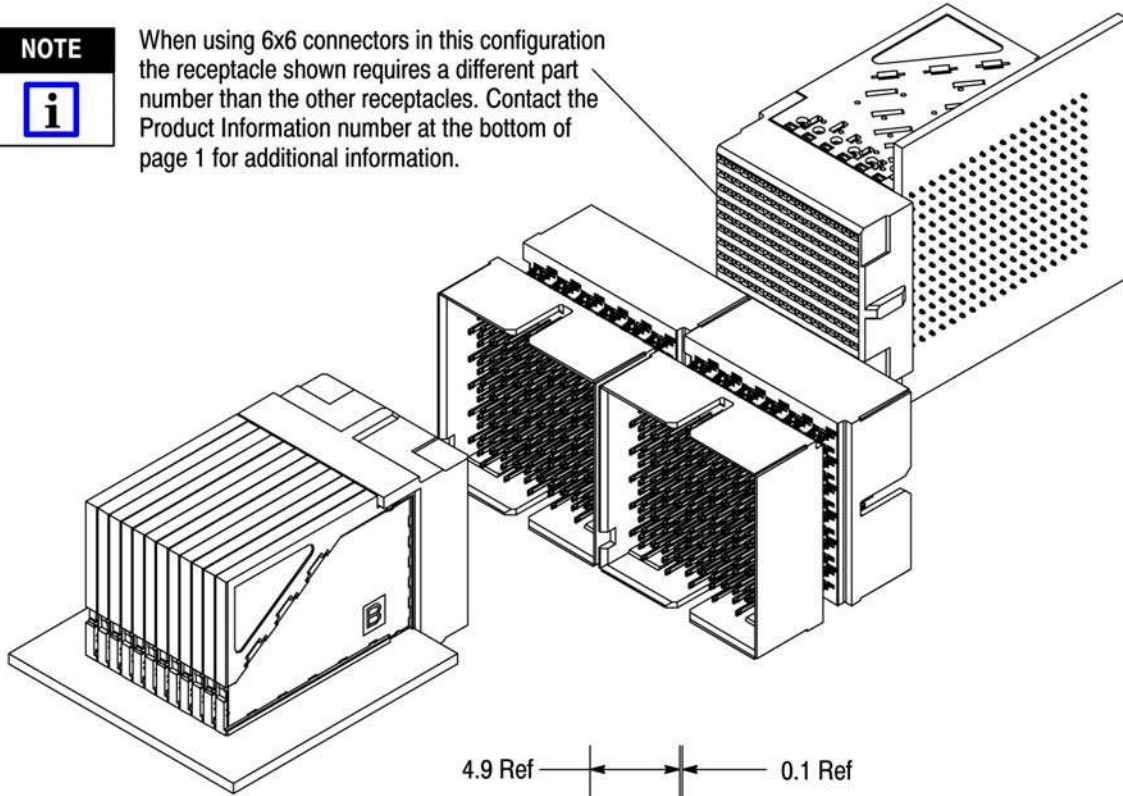

6x12 shown, mid-plane not shown for clarity. Refer to customer drawings for complete column and row designations.

Figure 8A

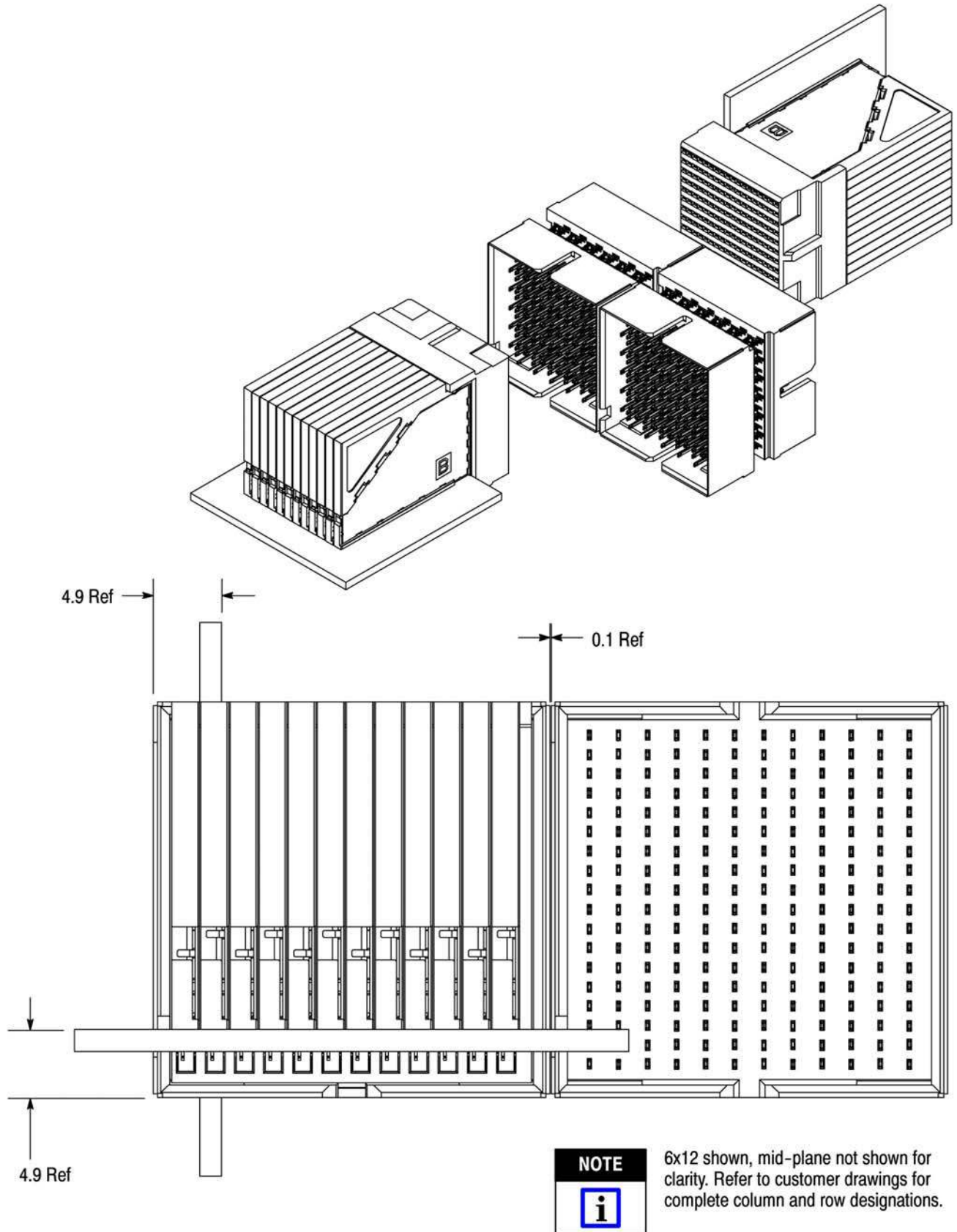

Figure 8B

3.6. Co-Planer Applications

Refer to Figure 9 for co-planer applications.

NOTE: 4-Pair, 8-Column Shown

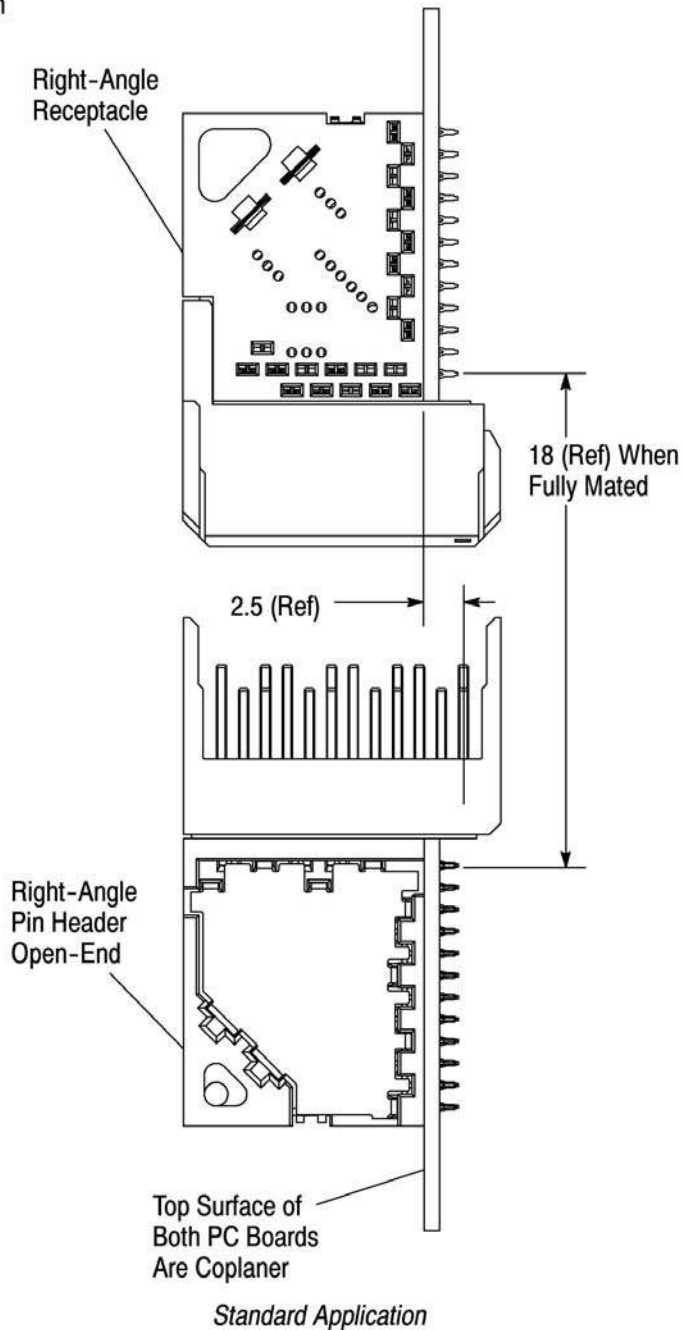

Figure 9

3.7. PC Board Requirements

A. PC Board Thickness

Vertical or right-angle pin header connectors and vertical or right-angle receptacle connectors with compliant pin contacts require a minimum backplane thickness of 1.40 mm to allow for positive retention of the compliant pin contact. Mid-plane applications require a minimum backplane thickness of 4.1 mm for a tail length of 1.8 mm, and a minimum backplane thickness of 5.5 mm for tail length of 2.5 mm. Thicker backplanes will not effect the retention of the compliant pin contact.

NOTE

For circuit routing concerns, contact TE Product Information at the phone number listed at the bottom of page 1.

B. PC Board Hole Pattern Layout

The pc board hole patterns for the placement of the Z-PACK TinMan connectors are provided on the applicable Customer Drawing. Recommended spacing for vertical pin header open-end and right-angle receptacle connectors with power modules are shown in Figure 10. Component side shown.

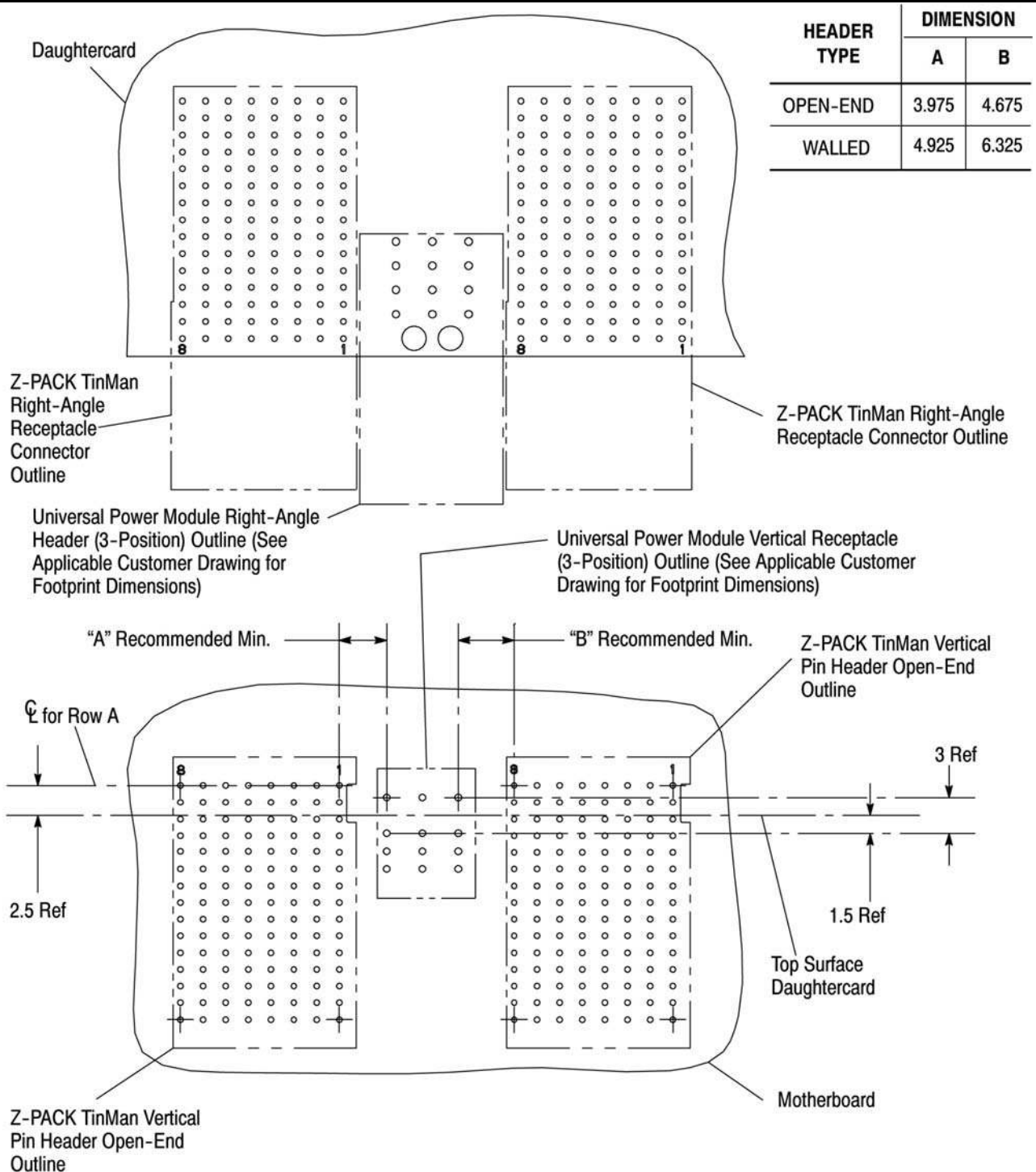

Figure 10

3.8. Contact Hole Configuration

The holes in the pc board for all contacts must be drilled and plated through to the dimensions shown in Figure 11.

NOTE



The nominal finished hole diameter ("A" dimension) is supplied for reference only. While it may be used as an inspection dimension, proper plated through hole composition can only be determined via radial and longitudinal cross sectioning of the plated through hole. Radial sectioning verifies that the specified plated through hole component dimensions are achieved, i.e. drill diameter, copper plating, and other specified plating thicknesses. Longitudinal sectioning will verify plating uniformity throughout the pc board thickness. Deviation from the requirements listed in Figure 11 may have adverse effects on compliant pin insertion force and related performance.

If pc boards are to be back-drilled (counterbored) for signal integrity performance, refer to the dimensions provided in Figure 11B.

11A

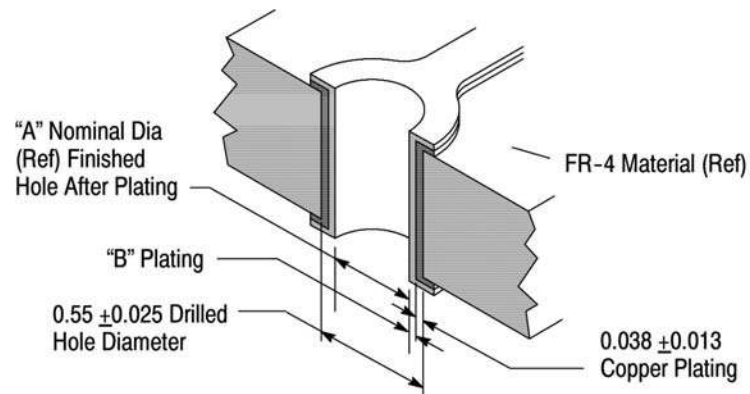

11B

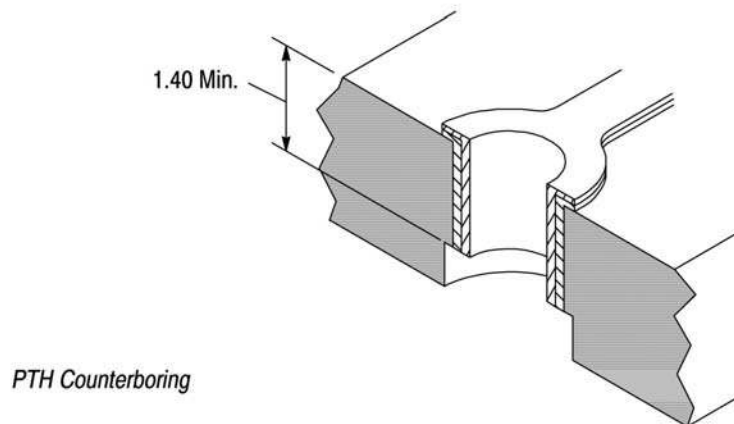

CONNECTOR	PLATING	"A" DIMENSION	"B" DIMENSION
Header and Receptacle	Tin	0.47	0.0005-0.004
	Tin/Lead	0.46	0.008 +0.004
	Organic Solderability Preservative (OSP)	0.47	0.0002-0.0005
	Au	0.47	0.0001-0.0005 Au Over 0.00127-0.0026 Ni
	Ag	0.47	0.0003 +0.0002
	Hot Air Solder Leveling (HASL) Tin-Lead	0.46	0.004-0.012
	Hot Air Solder Leveling (HASL) Lead Free	0.47	0.0005-0.004

Figure 11

3.9. Connector Installation

A. Initial Positioning

Z-PACK TinMan vertical or right-angle pin headers, and vertical or right-angle receptacles typically are pre-applied to a pc board by hand.

Connectors should be gripped by the housing and/or chicklets only and not by the contacts. When placing a connector into a pc board, all contact leads should be aligned and inserted into the pc board simultaneously to prevent twisting or bending of the contacts.

When placing a right-angle receptacle on a pc board, align the row of contact leads closest to the pc board edge first, and continue aligning the remainder of the rows by rolling the receptacle from front to back.

NOTE

Z-PACK TinMan connectors must be placed on the pc board so that pin 1 to pin1 orientation is maintained. For contact 1 indicators, see Figure 12.

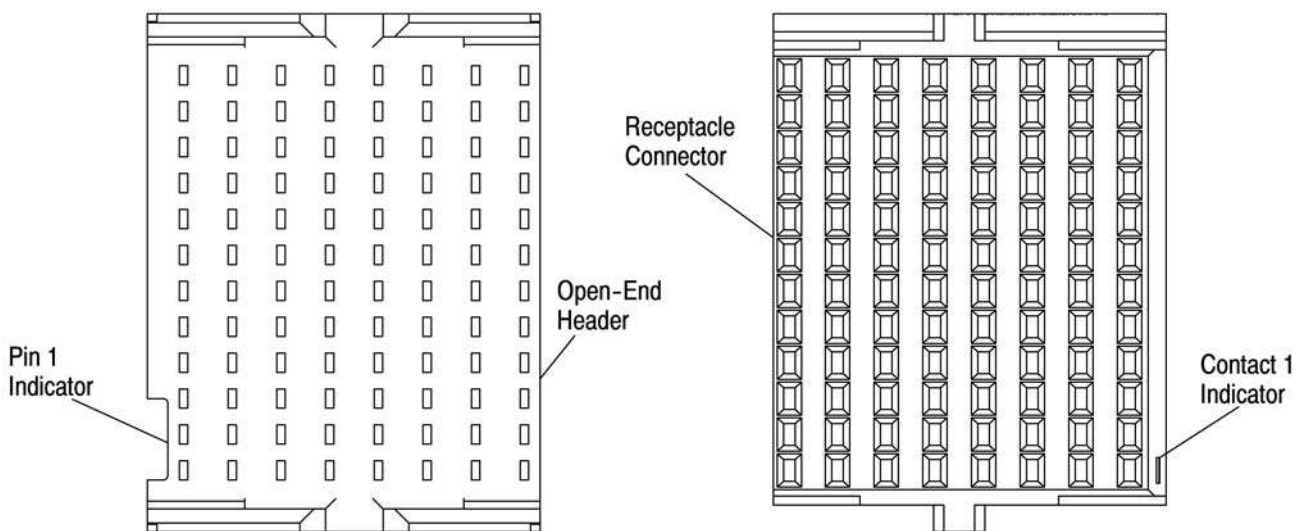

Figure 12

B. Seating Connectors

Seating force must be applied evenly on the connectors to prevent deformation or other damage to the contacts and housings. When installing vertical header connectors, the insertion force must be evenly applied to the assembly using the appropriate seating tool. When installing vertical receptacle, right-angle receptacle, or right-angle header connectors, the insertion force must be evenly applied to the assembly (as shown in Figure 13). Refer to Paragraph 3.10 for seating force information. Seating force will vary according to pc board variations and signal pin count. Tooling recommendations are covered in Section 5.

CAUTION



Correct seating of connector is essential to interconnection performance. This includes correct seating height (see Figure 13) and force applied. Over-seating of product will deform parts critical to the quality of the connector. Maximum force occurs prior to the connector bottoming on the pc board.

3.10. Connector Seating Height

Z-PACK TinMan Header Connectors with compliant pin contacts are seated using seating tools. See Figure 15. These tools may be used in the application machines listed in Section 5, TOOLING, or with a suitable machine capable of supplying a minimum controllable downward force of 44.5 N [10 lbs] per compliant pin contact. Pin headers and receptacles must be seated to the dimensions shown in Figure 13.

For mid-plane applications using vertical headers, a second tool must be used, (as the pc board support), when pressing the second connector as shown in Figure 13C.

13A

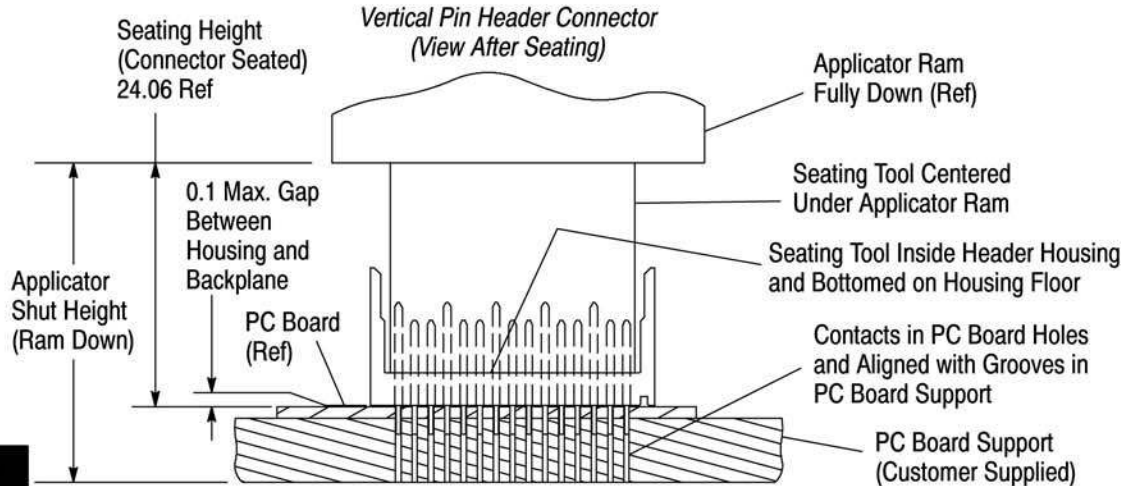

NOTE

The seating height (24.06) is a reference starting point. Seating height may need adjustment to obtain the 0.1 maximum gap between the connector and the pc board.

13B

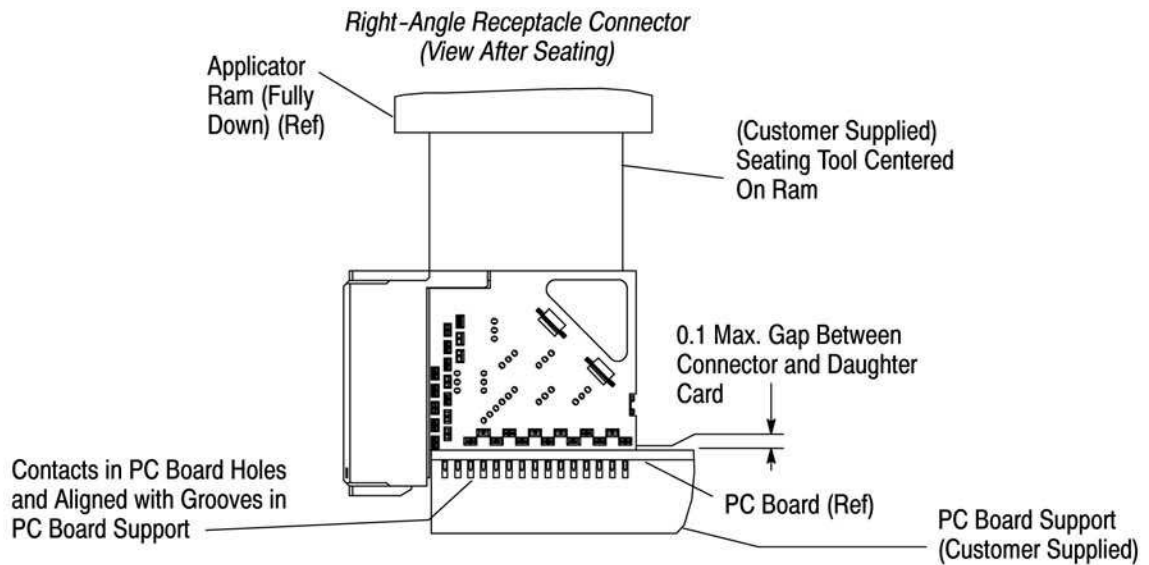

13C

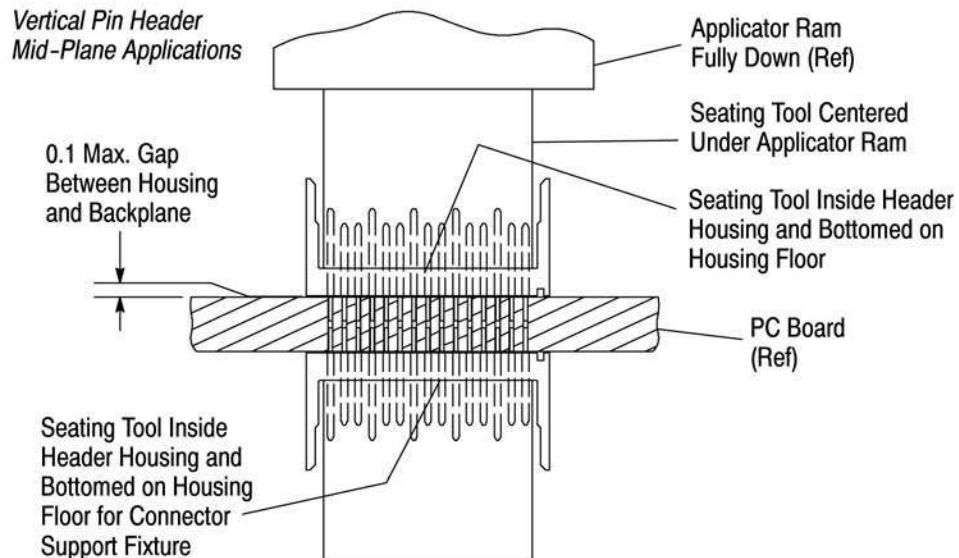

Figure 13 (Cont'd)

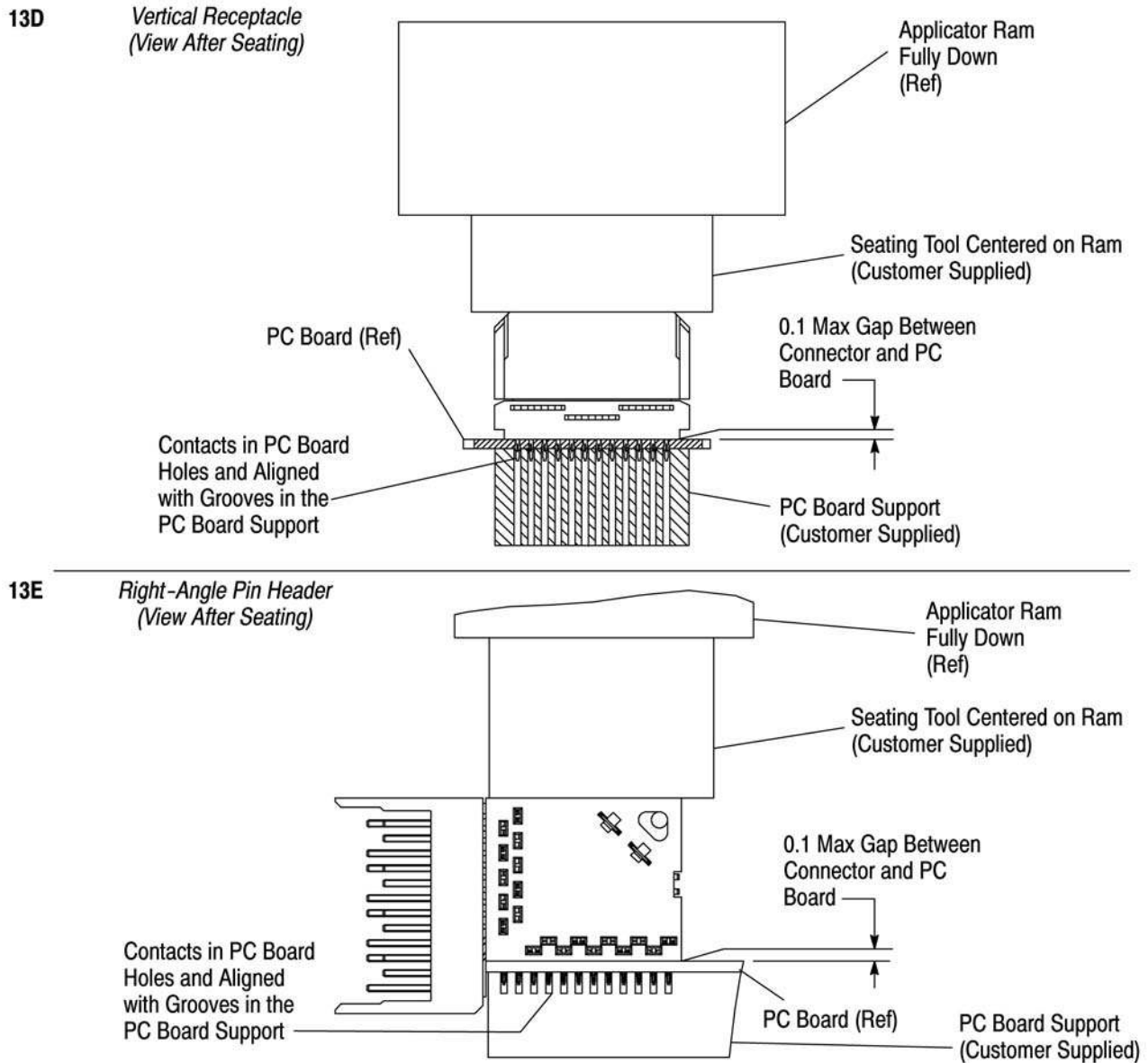

Figure 13 (End)

3.11. Solder Process Considerations

Since the Z-PACK TinMan connector system is a press-in compliant pin type of design, it does not require solder. But, when pc board repair or rework requires soldering after the connectors are already inserted in the pc board, the following applies:



Even when using “no clean” solder paste, it is imperative that the contact interface be kept clean of flux and residue, since it acts as an insulator.



Consideration must be given to toxicity and other safety requirements recommended by the solvent manufacturer. Trichloroethylene and Methylene Chloride can be used with no harmful affect to the connectors; however, TE does not recommend them because of the harmful occupational and environmental effects. Both are carcinogenic (cancer-causing) and Trichloroethylene is harmful to the earth's ozone layer.

3.12. Accessories

Universal and Keyed Guide Pins and Modules, and Advanced TCA Guide Pins and Modules are available for your production and assembly needs. See Figure 14. The guide pin and female guide module are designed to help in connector alignment. Interaction of these two pieces of hardware provide error-free mating and prevents mating damage to the connector housings and contacts. They are also recommended for multi-connector, large and heavy daughter card applications, and conditions where the mis-alignment tolerances shown in Paragraph 3.3 cannot be met. See Figures 1 and 14.

Insertion of the guide modules and pins into the pc boards must be applied with tooling which will apply between 222-667 N•m [50-150 lb-in.] downward pressure. Refer to Figure 14 for customer supplied seating tool dimensions. The guide pin and modules must be fully seated on the pc board.

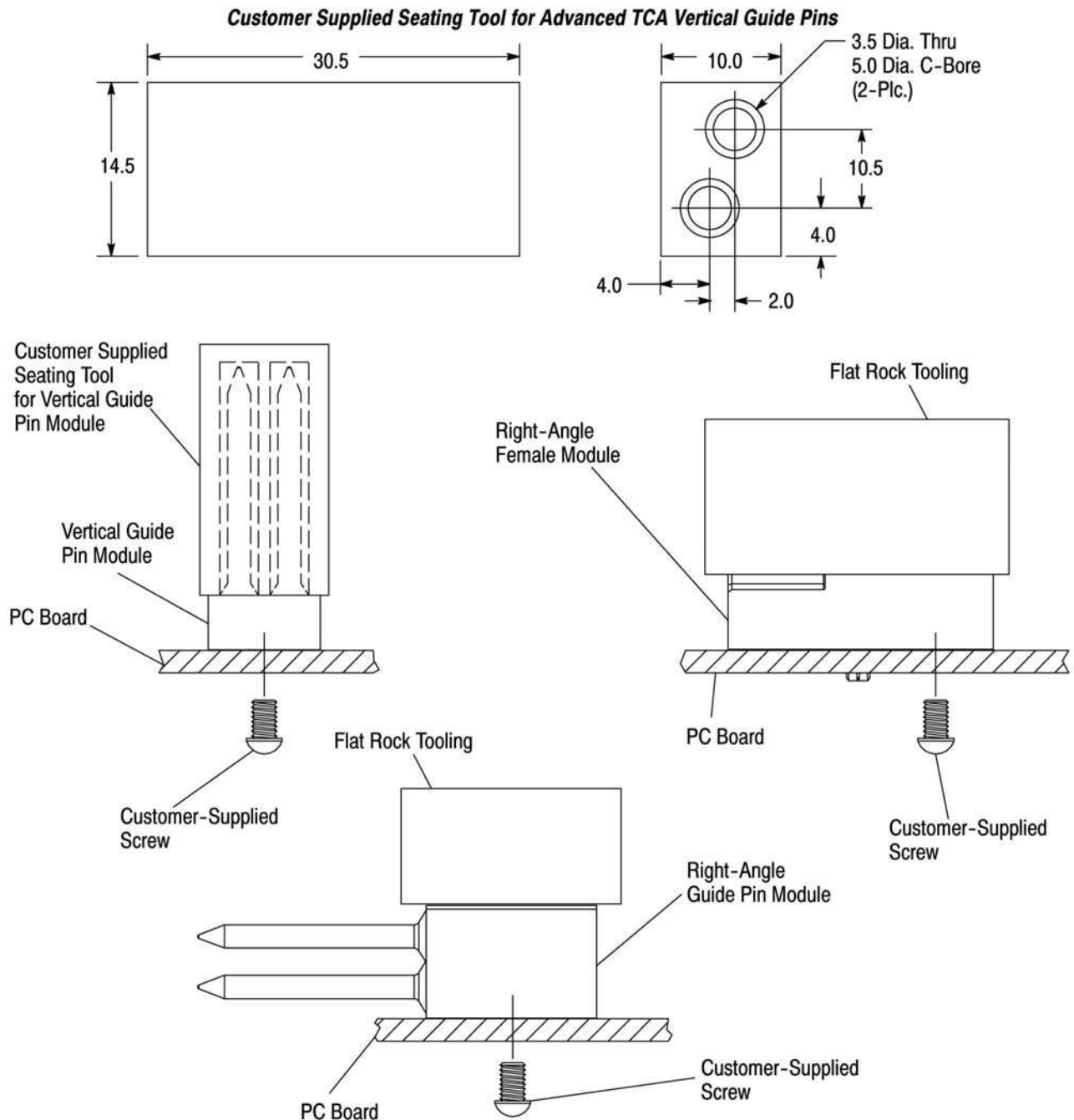

Figure 14 (Cont'd)

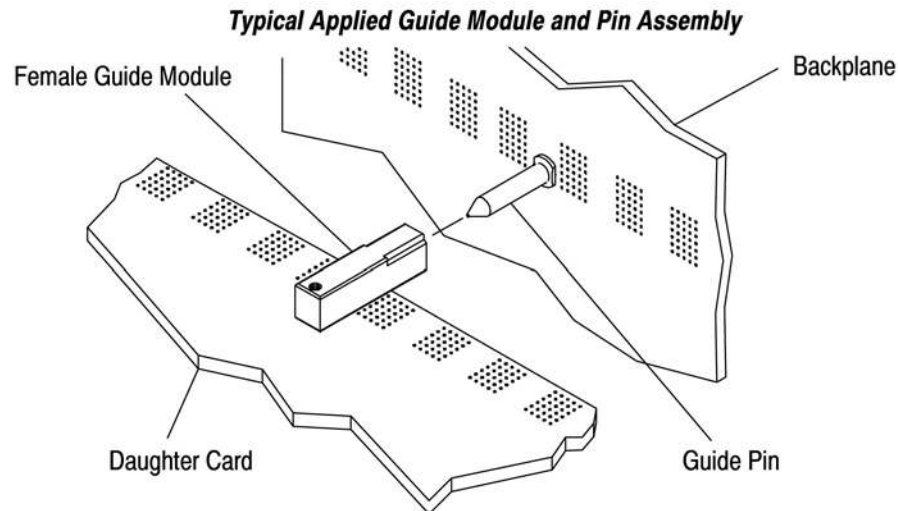

Figure 14 (End)

3.13. Repair/Replacement

A. Header Repair

In cases where only individual pin contacts are in need of replacement, header assemblies can be repaired without removal from the pc board. Refer to Instruction Sheet 408-10197 for information on extraction tool 1976935-1 and Instruction Sheet 408-10196 for information on insertion tool 1976930-1.

B. Receptacle Repair

Receptacle construction does not allow for replacement of individual contacts. Damaged receptacles must be completely replaced.

4. QUALIFICATIONS

Z-PACK TinMan connectors have been Recognized by Underwriters Laboratories, (UL) in File E28476, Vol 57. Z-PACK TinMan orthogonal connectors have not yet been submitted for agency evaluation.

5. TOOLING

Figure 15 provides tooling part numbers related to the Z-PACK TinMan Connector System.

- PC Board Support

A pc board support must be used to prevent bowing of the pc board during the insertion of a connector into the board. It should have flat surfaces with holes or a channel wide and deep enough to receive any contact compliant pins that may protrude below the pc board surface during installation of the connector.

- Seating Tools

Seating tools have been designed to push on the contact and seat the connector on the pc board. The tool will prevent contacts from backing out of the housing and prevent damage to the housing.

- Power Units

Power units are automatic or semi-automatic machines used to assist in the application of a product. A power unit supplies the force to seat the connector onto the pc board using seating tools. Power for the insertion tool must be provided by application tools (with a ram) capable of supplying a downward force of 44.5 N [10 lb] per contact.

- Arbor Frame Assembly

Manual arbor frame assemblies are used to exert a downward force used to apply connectors to a pc board using seating tools. Commercially made arbor frame assemblies are available.

CONNECTOR					TOOLING				
PAIR	COLUMN	CONTACT PIN LENGTH			STANDARD	REVERSE	INSTRUCTION SHEET	INSERT. TOOL	EXT. TOOL
		GROUND	SIGNAL	3.8 LOCATION					
3	6	6.0	4.5	---	1-1901457-4	---	408-10041	1976930-1 (408-10196)	1976935-1 (408-10197)
	8	6.0	4.5	---	1-1901457-1	---			
		6.0	4.5/3.8	H8, I8	2063414-1	---			
	10	6.0	4.5	---	1-1901457-2	---			
	16	6.0	4.5	---	1-1901457-3	---			
4	6	6.0	4.5	---	1-1804790-6	---			
	8	6.0	4.5	---	1-1804790-1	1-1804792-1			
	10	6.0	4.5	---	1804790-5	---			
	14	6.0	4.5	---	1-1804790-5	---			
	16	6.0	4.5	---	1-1804790-3	1-1804792-3			
5	6	6.0	4.5	---	1-1804791-8	---			
		6.0	4.5/3.8	K6, L6	2018488-1	---			
	8	6.0	4.5	---	1-1804791-1	1-1804793-1			
		6.0	4.5/3.8	N8, O8	2063416-1	---			
		6.0	4.5/3.8	A1, B1, N8, O8	2018276-1	---			
	10	6.0	4.5	---	1-1804791-7	---			
	14	6.0	4.5	---	1-1804791-6	---			
	16	6.0	4.5	---	1-1804791-3	1-1804793-3			
6	8	6.0	4.5	---	2063381-1	---			
		6.0	4.5/3.8	Q8, R8	2018518-1	---			
	10	6.0	4.5	---	2063381-2	---			
	16	6.0	4.5	---	2063381-3	---			
6X12 Orthogonal	6.0	4.5	---	2018279-1	---	---			
4X10 Power Hybrid	6.0	4.5	A3, B3	2018460-1	---	408-10323			

Figure 15 (Cont'd)

NOTE: Typical power units from Tyco Electronics Automation Group include, but are not limited to the following.

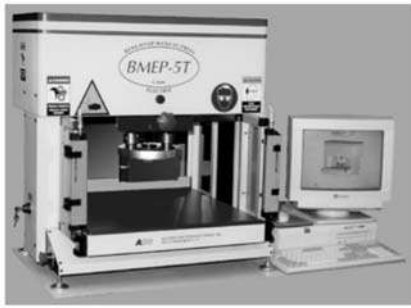

1585696-1
Model BMEP 5T



1585699-1
Model MEP 6T

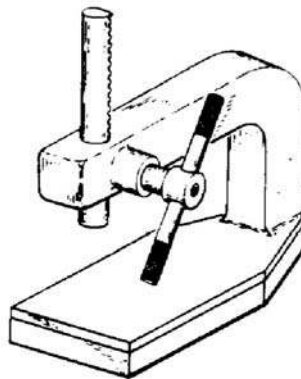

Manual Arbor
Frame Assembly
(Commercially
Available)

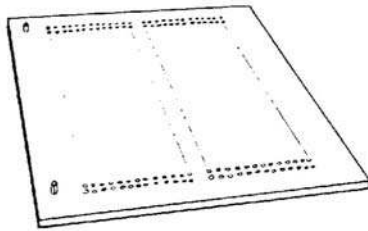

PC Board Support
(Customer Supplied)

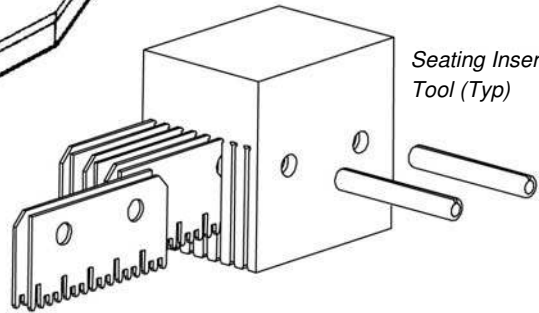

Seating Insertion
Tool (Typ)



Insertion Tool
1976930-1



Extraction Tool
1976935-1

Figure 15 (End)

6. VISUAL AID

The illustration below shows a typical application of this product. This illustration should be used by production personnel to ensure a correctly applied product. Applications which DO NOT appear correct should be inspected using the information in the preceding pages of this specification and in the instructional material shipped with the product or tooling.

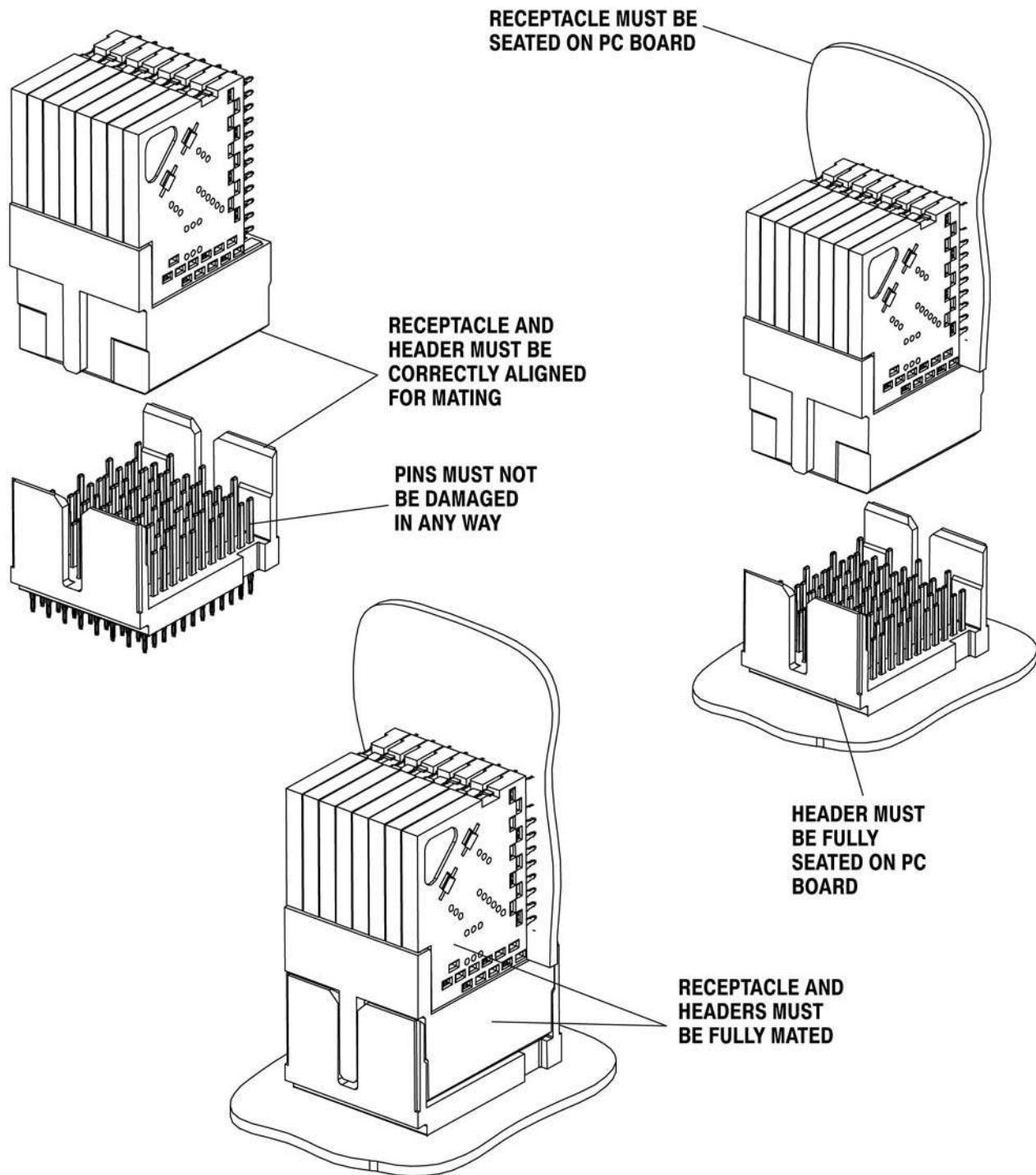

FIGURE 16. VISUAL AID