

## Uncompensated, High Slew Rate High Output Current, Operational Amplifier

March 1993

### Features

- High Slew Rate..... 150V/ $\mu$ s
- Fast Settling..... 200ns
- Wide Power Bandwidth..... 2MHz
- Wide Gain Bandwidth ( $A_v \geq 3$ )..... 20MHz
- High Input Impedance..... 130M $\Omega$
- Low Offset Current..... .5nA
- High Output Current.....  $\pm 30$ mA

### Applications

- Data Acquisition Systems
- R.F. Amplifiers
- Video Amplifiers
- Signal Generators
- Pulse Amplification

### Ordering Information

PART NUMBER	TEMP. RANGE	PACKAGE
HA2-2529-2	-55°C to +125°C	8 Pin Can
HA2-2529-5	0°C to +75°C	8 Pin Can
HA3-2529-5	0°C to +75°C	8 Lead Plastic DIP
HA7-2529-2	-55°C to +125°C	8 Lead Ceramic DIP
HA7-2529-5	0°C to +75°C	8 Lead Ceramic DIP
HA9P2529-5	0°C to +75°C	8 Lead SOIC

### Description

The HA-2529 is a monolithic operational amplifier which typifies excellence of design. With a design based on years of experience coupled with the reliable dielectric isolation process, this amplifier provides an outstanding combination of DC and AC parameters at closed loop gains greater than 3.

The HA-2529 offers 150V/ $\mu$ s slew rate and fast settling time (200ns), while consuming a mere 6mA of quiescent current, making this amplifier ideal for video circuitry and data acquisition designs. With 20MHz gain bandwidth combined with 7.5kV/V open loop gain, the HA-2529 is an ideal component for demanding signal conditioning designs. This device provides  $\pm 30$ mA output current drive with an output voltage swing of  $\pm 10$ V making it suited for pulse amplifier and R.F. amplifier components.

The HA-2529 will upgrade output current, slew rate, offset voltage drift and offset current drift in systems presently using the HA-2520/22/25 or EHA-2520/22/25.

Mil-Std-883 product and data sheets are available upon request.

### Pinouts

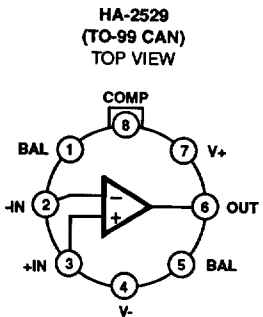
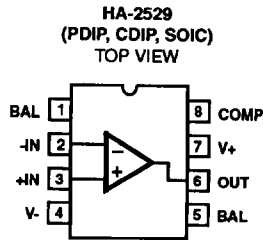

### Schematic Diagram

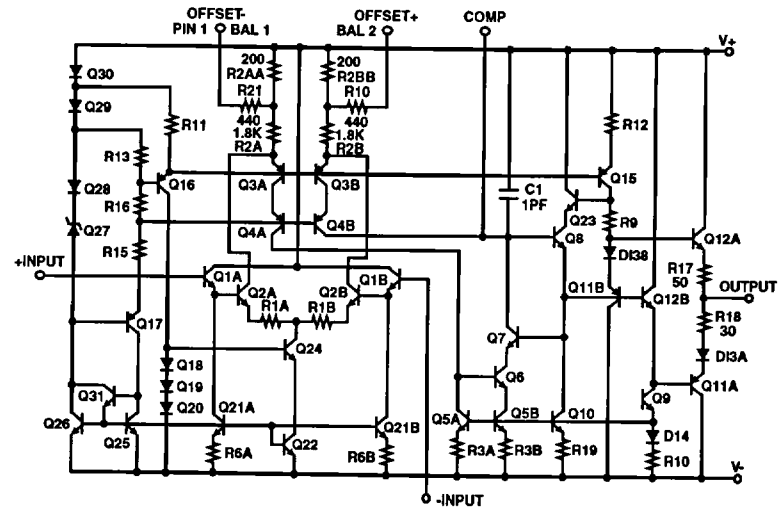

CAUTION: These devices are sensitive to electrostatic discharge. Users should follow proper I.C. Handling Procedures.  
Copyright © Harris Corporation 1993

File Number 2895.1

## Specifications HA-2529

### Absolute Maximum Ratings (Note 1)

Voltage Between V+ and V- Terminals	40.0V
Differential Input Voltage	15V
Peak Output Current	90mA
Internal Power Dissipation (Note 10)	300mW
Junction Temperature	+175°C
Junction Temperature (Plastic Package)	+150°C
Lead Temperature (Soldering 10 Sec.)	+300°C

### Operating Conditions

Operating Temperature Range	-55°C ≤ T <sub>A</sub> ≤ +125°C
HA-2529-2	0°C ≤ T <sub>A</sub> ≤ +75°C
HA-2529-5	-65°C ≤ T <sub>A</sub> ≤ +150°C

**CAUTION:** Stresses above those listed in "Absolute Maximum Ratings" may cause permanent damage to the device. This is a stress only rating and operation of the device at these or any other conditions above those indicated in the operational sections of this specification is not implied.

### Electrical Specifications V<sub>S</sub> = ±15V, C<sub>L</sub> = 50pF, R<sub>L</sub> = 2kΩ, Unless Otherwise Specified

PARAMETER	TEMPERATURE	HA-2529-2 -55°C to +125°C			HA-2529-5 0°C to +75°C			UNITS
		MIN	TYP	MAX	MIN	TYP	MAX	
<b>INPUT CHARACTERISTICS</b>								
Offset Voltage (Note 8)	+25°C	-	2	5	-	2	10	mV
	Full	-	-	8	-	-	14	mV
Average Offset Voltage Drift (Note 8)	Full	-	10	-	-	10	-	μV/°C
Bias Current (Note 8)	+25°C	-	50	200	-	50	250	nA
	Full	-	80	400	-	80	400	nA
Average Bias Current Drift (Note 8)	Full	-	0.2	-	-	0.2	-	nA/°C
Offset Current (Note 8)	+25°C	-	5	25	-	5	50	nA
	Full	-	10	50	-	10	100	nA
Average Offset Current Drift	Full	-	0.02	-	-	0.02	-	nA/°C
Common Mode Range	Full	±10	±13	-	±10	±13	-	V
Differential Input Resistance (Note 11)	+25°C	50	130	-	50	130	-	MΩ
Differential Input Capacitance	+25°C	-	3	-	-	3	-	pF
Input Noise Voltage (f = 1kHz)	+25°C	-	20	-	-	20	-	nV/√Hz
Input Noise Current (f = 1kHz)	+25°C	-	1.8	-	-	1.8	-	pA/√Hz
<b>TRANSFER CHARACTERISTICS</b>								
Large Signal Voltage Gain (Note 3)	+25°C	10	18	-	7.5	18	-	kV/V
	Full	7.5	15	-	5	15	-	kV/V
Common Mode Rejection Ratio (Note 5)	Full	80	100	-	74	100	-	dB
Gain Bandwidth Product (Note 2, 11)	+25°C	15	20	-	15	20	-	MHz
Minimum Stable Gain	+25°C	3	-	-	3	-	-	V/V
<b>OUTPUT CHARACTERISTICS</b>								
Output Voltage Swing	Full	±10	±12	-	±10	±12	-	V
Full Power Bandwidth (Notes 3 & 6)	+25°C	2.1	2.6	-	2.1	2.6	-	MHz
Output Current (Note 8)	+25°C	30	35	-	30	35	-	mA
	Full	25	30	-	25	30	-	mA
Output Resistance (Open Loop)	+25°C	-	30	-	-	30	-	Ω
<b>TRANSIENT RESPONSE (A<sub>v</sub> = +3)</b>								
Rise Time (Note 2, 7)	+25°C	-	20	45	-	20	50	ns
Overshoot (Note 2, 7)	+25°C	-	10	30	-	10	30	%
Slew Rate (Note 3, 7)	+25°C	135	150	-	135	150	-	V/μs
Settling Time (Note 4, 7)	+25°C	-	200	-	-	200	-	ns

**2**  
OPERATIONAL  
AMPLIFIERS

## Specifications HA-2529

### Electrical Specifications $V_S = \pm 15V, C_L = 50pF, R_L = 2k\Omega$ , Unless Otherwise Specified (Continued)

PARAMETER	TEMPERATURE	HA-2529-2 -55°C to +125°C			HA-2529-5 0°C to +75°C			UNITS
		MIN	TYP	MAX	MIN	TYP	MAX	
<b>POWER SUPPLY CHARACTERISTICS</b>								
Supply Current	Full	-	4.5	6	-	4.5	6	mA
Power Supply Rejection Ratio (Note 12)	Full	80	90	-	74	90	-	dB

**NOTES:**

1. Absolute maximum ratings are limiting values, applied individually beyond which the serviceability of the circuit may be impaired. Functional operability under any of these conditions is not necessarily implied.
2.  $V_{OUT} = \pm 200mV, A_V \geq 3$ .
3.  $V_{OUT} = \pm 10V$ .
4. Settling Time is specified to 0.1% of final value for a 10V output step and  $A_V = -3$ .
5.  $\Delta V_{CM} = \pm 10V$ .
6. Full Power Bandwidth is guaranteed by equation:  $FPBW = \frac{\text{Slew Rate}}{2\pi V_{PEAK}}$ .
7. See Transient Response and Settling Time Test Circuits.
8. Refer to typical performance curve in data sheet.
9.  $V_{OUT} = \pm 5V$ .
10. Refer to package thermal constants in Die Characteristics section.
11. Parameter is guaranteed by design and characterization data.
12.  $\Delta V_S = \pm 10V$  to  $\pm 20V$ .

### Die Characteristics

Transistor Count	40	
Die Dimensions	57 x 67 x 19 mils	
Substrate Potential	V-	
Process	Bipolar-DI	
Thermal Constants (°C/W)	$\theta_{JA}$	$\theta_{JC}$
Metal Can	117	36
Plastic Mini-DIP	96	34
Ceramic Mini-DIP	115	36
SOIC	157	43

### Settling Time Circuit

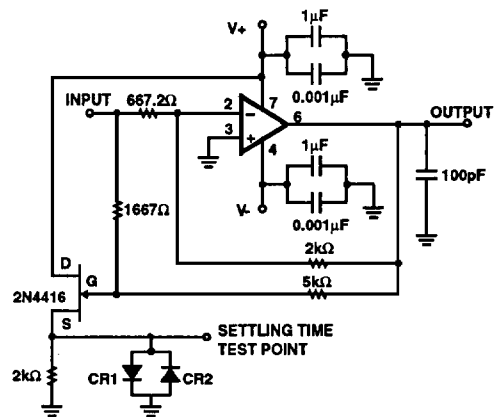

- $A_V = -3$
- Feedback and summing resistor ratios should be 0.1% matched.
- Clipping diodes CR1 and CR2 are optional. HP5082-2810 recommended.

Test Circuits

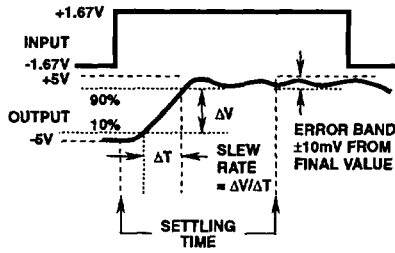

FIGURE 1. SLEW RATE AND SETTLE TIME

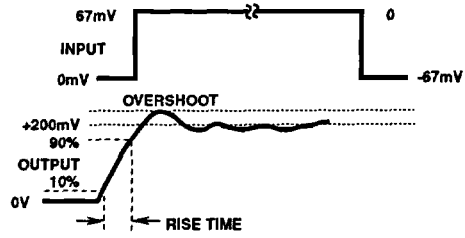

FIGURE 2. TRANSIENT RESPONSE

NOTE: Measured on both positive and negative transitions from 0V to +200mV and 0V to -200mV at the output.

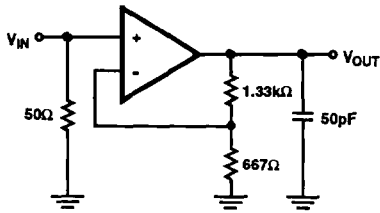

FIGURE 3. SLEW RATE AND TRANSIENT RESPONSE

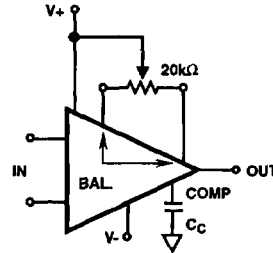
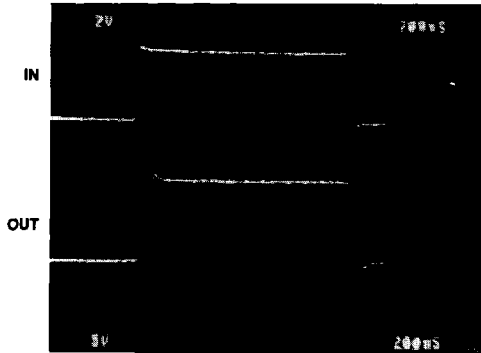

FIGURE 4. SUGGESTED  $V_{OS}$  ADJUSTMENT AND COMPENSATION HOOK UP

Tested offset adjustment range is  $|V_{OS} + 1mV|$  minimum referred to output. Typical ranges are +28mV to -18mV with  $R_T = 20k\Omega$

LARGE SIGNAL RESPONSE

Horizontal Scale: (200ns/Div.)  
Vertical Scale: (2V/Div. Input)  
(5V/Div. Output).



SMALL SIGNAL RESPONSE

Horizontal Scale: (200ns/Div.)  
Vertical Scale: (50mV/Div. Input)  
(100mV/Div. Output).

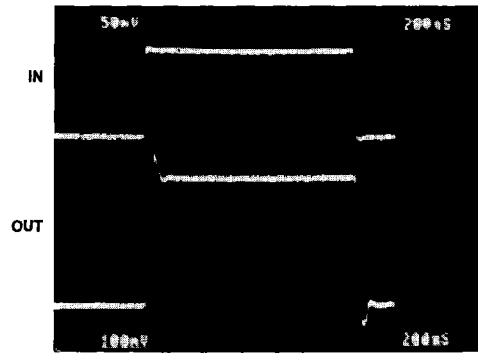

Typical Performance Curves

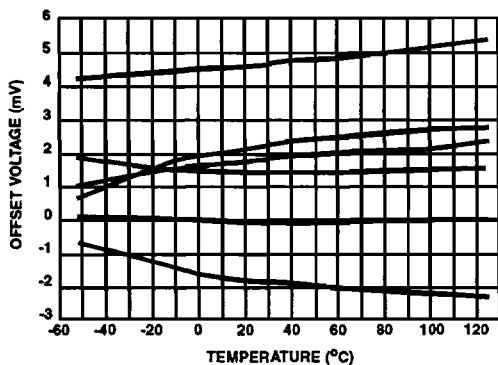

FIGURE 5. OFFSET VOLTAGE vs TEMPERATURE  
(6 TYPICAL UNITS FROM 3 LOTS AT  $V_S = \pm 15V$ )

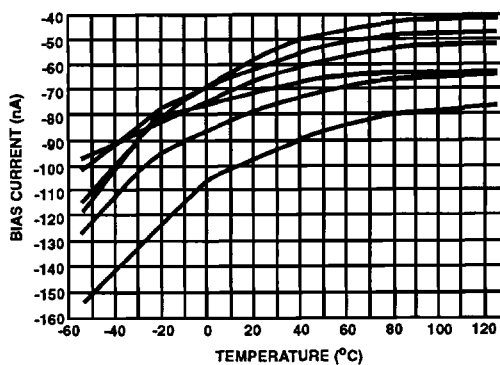

FIGURE 6. BIAS CURRENT vs TEMPERATURE  
(6 TYPICAL UNITS FROM 3 LOTS AT  $V_S = \pm 15V$ )

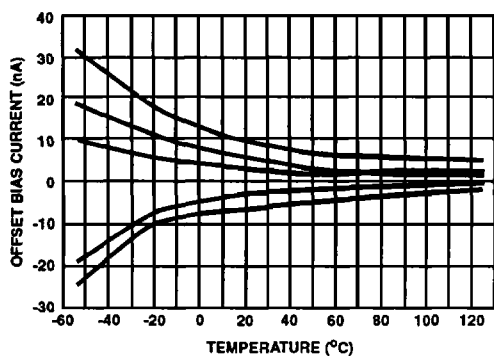

FIGURE 7. OFFSET CURRENT vs TEMPERATURE  
(5 TYPICAL UNITS FROM 3 LOTS AT  $V_S = \pm 15V$ )

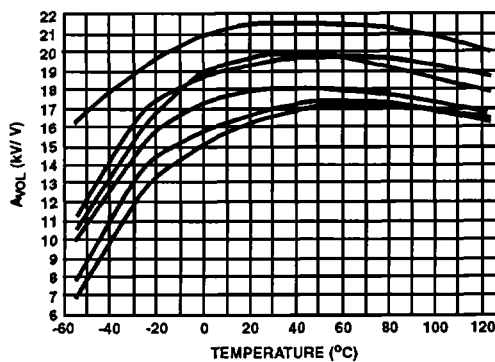

FIGURE 8. OPEN LOOP GAIN vs TEMPERATURE  
(6 TYPICAL UNITS FROM 3 LOTS AT  $V_S = \pm 15V$ )

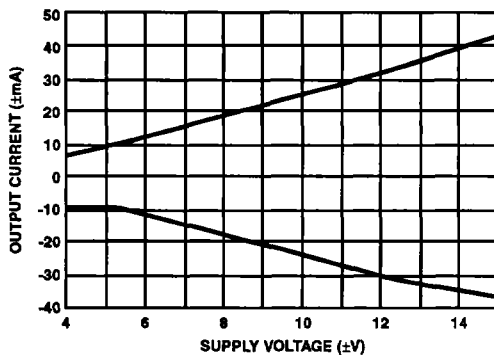

FIGURE 9. OUTPUT CURRENT vs SUPPLY VOLTAGE

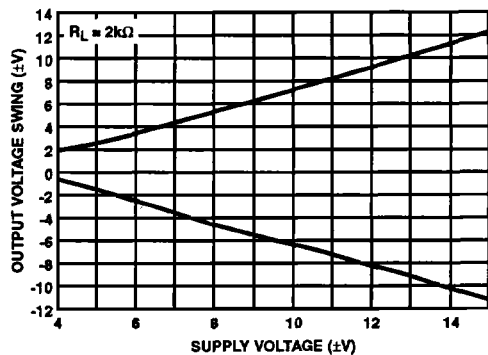

FIGURE 10. OUTPUT VOLTAGE SWING vs SUPPLY VOLTAGE

Typical Performance Curves (Continued)

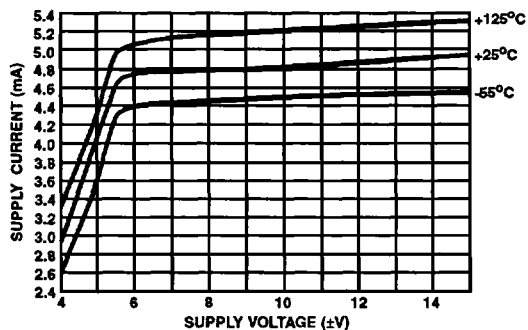

FIGURE 11. SUPPLY CURRENT vs SUPPLY VOLTAGE (OVER FULL TEMPERATURE)

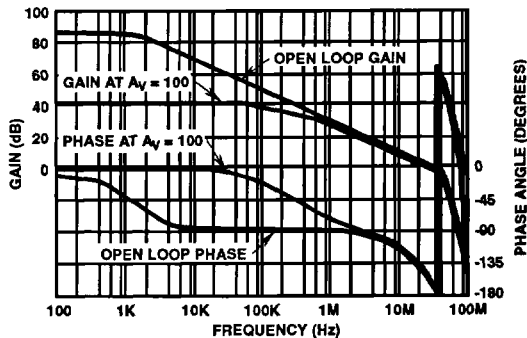

FIGURE 12. FREQUENCY RESPONSE AT VARIOUS GAINS

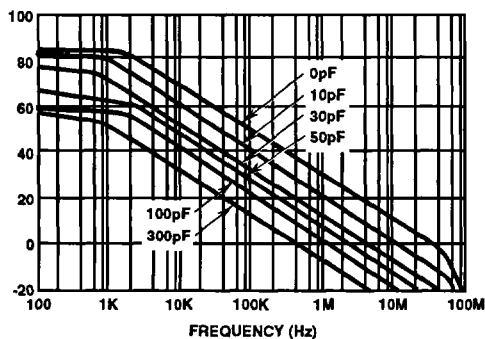

FIGURE 13. OPEN LOOP FREQUENCY RESPONSE FOR VARIOUS VALUES OF CAPACITORS FROM COMP PIN TO GROUND

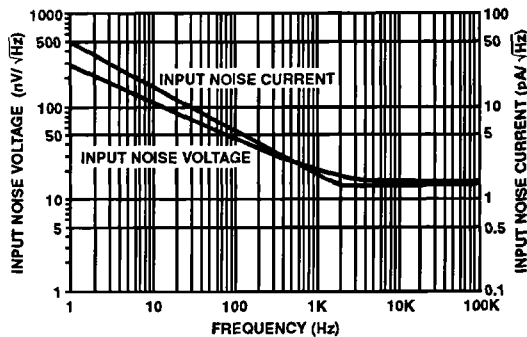

FIGURE 14. INPUT NOISE CHARACTERISTICS

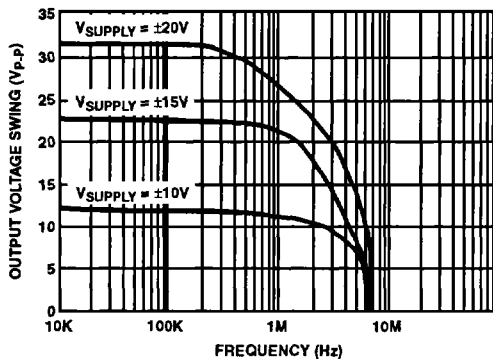

FIGURE 15. OUTPUT VOLTAGE SWING vs FREQUENCY

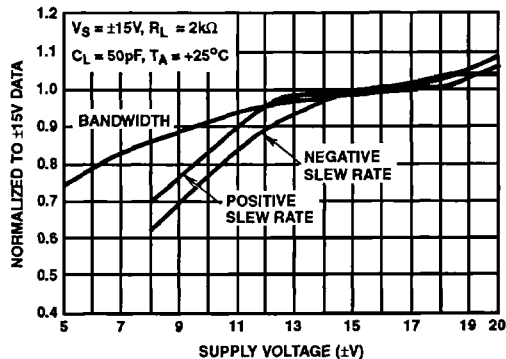
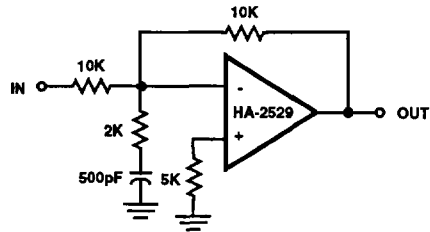

FIGURE 16. NORMALIZED AC PARAMETERS vs SUPPLY VOLTAGE

**Typical Applications**



**NOTES:**

- Compensation Circuit for  $A_v = -1$
- Slew Rate = 120V/ $\mu$ s
- Bandwidth = 10MHz
- Settling Time (0.1%) = 500ns
- Capacitance at pin 8 must be minimized for maximum bandwidth.
- Tested and functional with supply voltages from  $\pm 4V$  to  $\pm 15V$ .

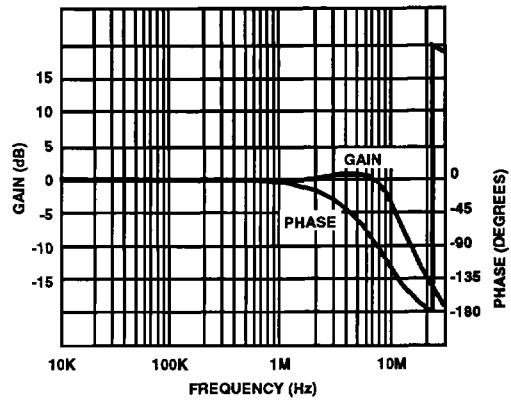

**FIGURE 17. FREQUENCY RESPONSE FOR INVERTING UNITY GAIN CIRCUIT**