

AEVT500 Series DC Contactor Specification 500AMPS/1800VDC



Product Facts

- Versatile power, voltage, and current operating range: 12-1800 Vdc;
- Excellent for safety disconnect and transfer switch applications;
- Built-in dual power coil economizer, 8w holding typical
- Hermetically “Super-sealed” environment uniquely protects contacts and all moving parts; can operate in harsh environment
- Auxiliary contacts optional
- 360KW power switch capable



Nomenclature

Example

AEVT500 –

C

A

Series code:

“AEVT500”=AEVT500 series

Coil Voltage Code:

“B” = 12 VDC

“C” = 24 VDC

Options:

Blank = Std. Options (Bottom Mount, Without Aux. Contact & Polarized Load Terminals)

“A” = With Aux. Contact (SPST-NO)



UL FILE NUMBER: E501749

AEVT500 Series DC Contactor Specification 500AMPS/1800VDC

Performance Data

MAIN CONTACT	LIFE	DATA	
Contact arrangement	1 Form X (SPST-NO DM)	500A @ 450VDC (make/break)	3,000 cycles
Rated Operating Voltage	12-1,800VDC	500A @ 650VDC (make/break)	1,000 cycles
Continuous (Carry) Current	500A ¹	Mechanical life	200,000 cycles
AUX. CONTACT			
Max short circuit current	3,300A @ 320VDC (1 cycle)	Aux. Contact Arrangement	SPST-NO (1 Form A)
Dielectric Withstanding Voltage	Between open contacts: 4,000VDC (leakage ≤ 1mA)	Aux. Contact Rating (Max Wattage)	10W
	Between contact and coil: 2,200Vrms (leakage ≤ 1mA)	Aux. Contact Rating (Max Voltage)	100 VDC
Insulation Resistance	Terminal to Terminal / Terminal to Coil	Aux. Contact Resistance (Max)	500mΩ
	New: Min 100MΩ @500VDC		
Voltage Drop (@350A)	≤ 70mV		
ENVIRONMENTAL DATA		OPERATE / RELEASE TIME	
Shock, 11ms ½ sine, operating	20G Peak	Close (includes bounce)	40ms, Max.
Vibration, Sine, Peak, 20G	10–1,000Hz	Release	20ms, Max.
Operating Ambient Temperature	-40 to +85°C		
Weight	3.38 lb (1.53 kg)		
COIL DATA			
Voltage rating		12Vdc	24Vdc
Pickup voltage (25 °C)		9.9Vdc	19.7Vdc
Dropout voltage (25 °C)		2Vdc	4Vdc
Inrush current @ nominal voltage ²		3.3A	1.7A
Holding current @ nominal voltage ²		0.74A	0.37A

Note:

*1: Current is relevant to cross-sectional area of conductor.

*2: Two coil design

AEVT500 Series DC Contactor Specification 500AMPS/1800VDC

Contact Rating. Estimated Make & Break Resistive Load Ratings

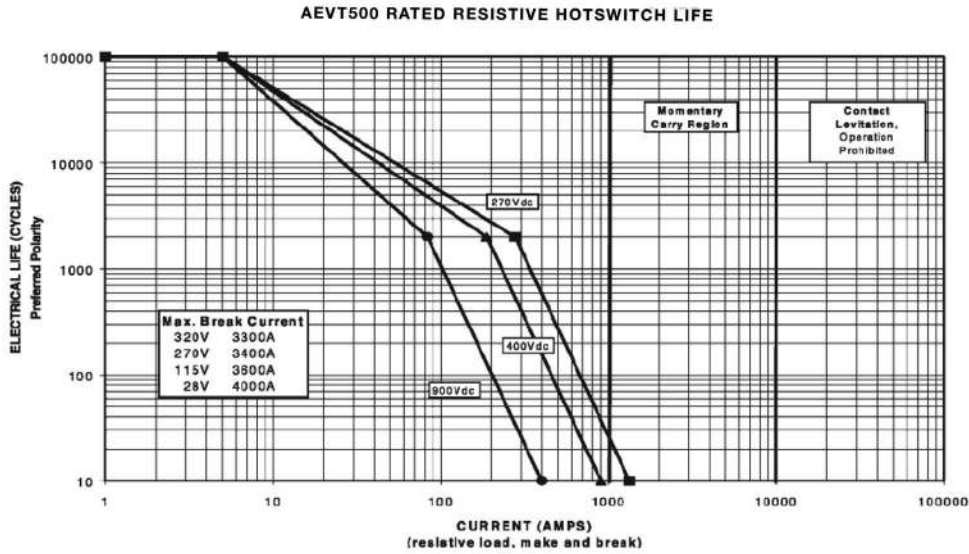

Outline Dimensions: inches (mm)

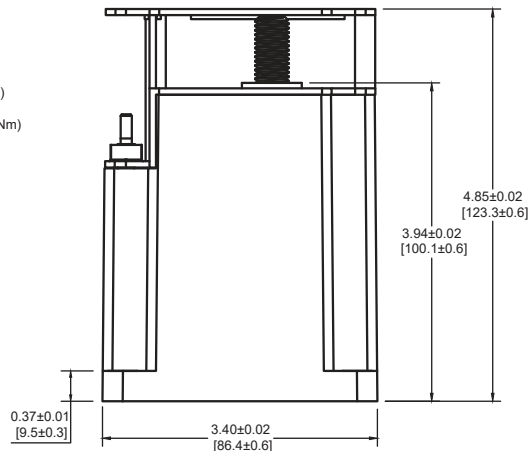
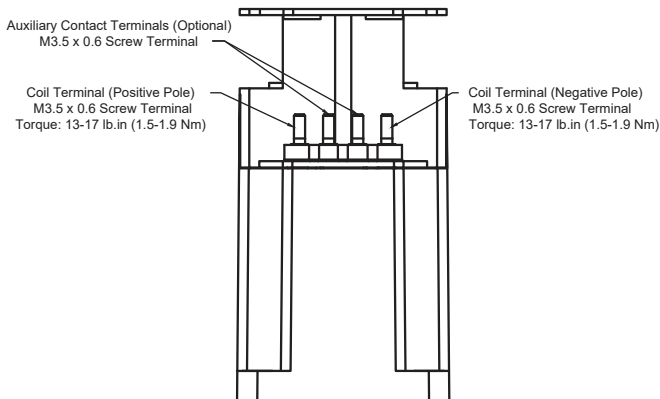
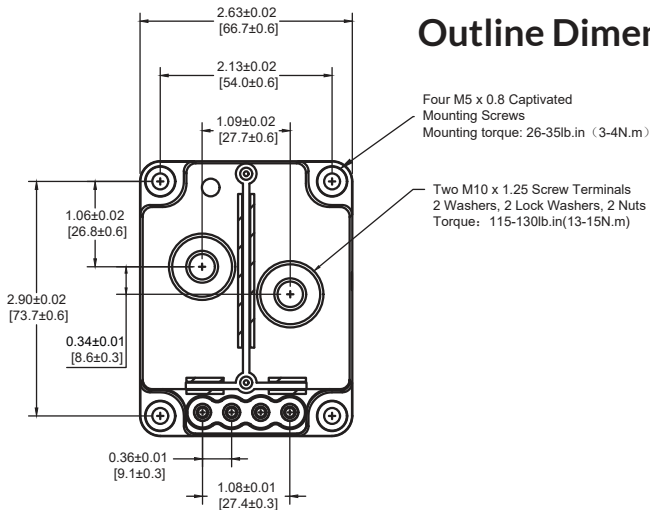

AEVT500 Series DC Contactor Specification 500AMPS/1800VDC

Application Note:

1. Be sure to use washer to prevent screws from loosening, all the terminals or copper bar must be in direct contact with the contactor's terminals.
 - Contact Terminal Torque: 115 - 130 lb.in (13 - 15 N.m)
 - Mounting Torque: 26 - 35 lb.in (3 - 4 N.m)
2. Contact terminals are polarized so refer to drawing during connecting. There is a reverse surge absorption circuit so that it is not necessary to use a surge protective device.
3. Do not use if dropped.
4. Avoid installing in a strong magnetic field (close to a transformer or magnet), or near a heat source.
5. Electrical life
Use per load capability and life cycle limits so as not to cause a function failure (treat the contactor as a product with specified life and replace it when necessary). It is possible to make parts burn around the contactor once operating failure occurs. It is necessary to take layout considerations into account and to make sure power shall be cut off within 1 second.
6. Avoid debris or oil contamination of the main terminals to optimize contact and avoid excess heat generation.