

| THIS DRAWING IS UNPUBLISHED.                                       | RELEASED FOR PUBLICATION | 20                              |           |
|--|--------------------------|---------------------------------|-----------|
| COPYRIGHT 20 BY TYCO ELECTRONICS CORPORATION. ALL RIGHTS RESERVED. |                          |                                 |           |
| PART NUMBER  | REVISION                 | DESCRIPTION                     | FEED TYPE |
| 2150321-2  | D                        | FINE CRIMP HEIGHT ADJUST        | PNEUMATIC |
| 7-2150321-2  | D                        | PNEUMATIC AND CRIMP TOOLING KIT | PNEUMATIC |
| 7-2150321-7  | A                        | CRIMP TOOLING KIT               | -         |

ATLANTIC VERSION TERMINATOR INTERFACE ADAPTER

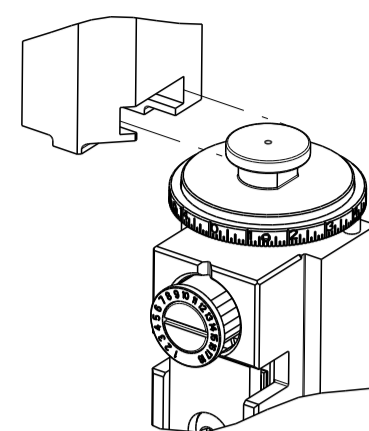

| APPLICATOR DATA                   |                  |      |
|-----------------------------------|------------------|------|
| CRIMP                             | SIZE             | TYPE |
| WIRE                              | 4.57 mm [ .180 ] | F    |
| INSUL                             | 7.62 mm [ .300 ] | F    |
| APPLICATOR INSTRUCTIONS 408-35043 |                  |      |

|   |                         |   |             |
|---|-------------------------|---|-------------|
| TERMINAL DATA: TE TERMINAL                          |                         | TE CRIMP SPECIFICATION                                      |             |
| TERMINAL NAME: .375 SERIES FASTIN-FASTON RECEPTACLE |                         |   |             |
| WIRE STRIP LENGTH<br>6.22-6.99 mm [ .245-.275 IN ]  |                         | INSULATION DIAMETER RANGE<br>Ø5.08-6.99 mm [ .200-.275 IN ] |             |
| TERMINAL APPLICATION SPECIFICATION                  | 114-20021               | -   | -           |
| TERMINALS APPLIED                                   |                         |   |             |
| TE TERMINAL<br>280755-2                             | TE TERMINAL<br>280755-4 | TE TERMINAL<br>281091-2                                     | TE TERMINAL |

| WIRE SIZE          | CRIMP HEIGHT mm [INCH]       | CRIMP HEIGHT REFERENCE SETTING |
|--------------------|------------------------------|--------------------------------|
| 10.00mm2           | 3.63+/-0.05 [ .143+/- .002 ] | 4.9                            |
| 6.0+2.5 or 8.50mm2 | 3.51+/-0.05 [ .138+/- .002 ] | 6.3                            |
| 8.00mm2            | 3.43+/-0.05 [ .135+/- .002 ] | 7.4                            |
| 6.00mm2            | 3.23+/-0.05 [ .127+/- .002 ] | 8.6                            |

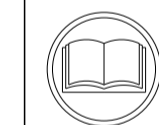

- RECOMMENDED SPARE PARTS
- REFER TO SUPPLIED INSTRUCTION SHEET FOR CLEANING, LUBRICATION AND STORAGE OF APPLICATOR.
- APPLY PART NUMBER 2-23419-6 LOCTITE TO THREADS OF ITEM 242. APPLY PART NUMBER 1-23419-5 LOCTITE TO THREADS OF ITEM 50.
- CRIMP HEIGHT REFERENCE SETTING WAS THE SETTING USED WHEN THE APPLICATOR WAS QUALIFIED AT THE FACTORY. ADJUSTMENT MAY BE NECESSARY WHEN RUNNING APPLICATOR IN THE FIELD.
- TERMINAL PITCH NOT COMPATIBLE WITH MECHANICAL FEED.
- 6. UNLESS SPECIFIED OTHERWISE TORQUE VALUES SHALL BE USED PER DOCUMENT, 101-35000.

**\*WARNING**  
ON INSTALLATION, SET WIRE DISC TO CRIMP HEIGHT REFERENCE SETTING FOR LARGEST WIRE SIZE. CRIMP HEIGHT REFERENCE SETTINGS GREATER THAN THE VALUE SHOWN MAY CAUSE DAMAGE TO THE CRIMP TOOLING. REFER TO THE INSTRUCTION SHEET FOR PROPER SETUP AND ADJUSTMENTS.

| LOC | DIST | REVISIONS |     |               |           |     |      |
|-----|------|-----------|-----|---------------|-----------|-----|------|
| A   | 66   | P         | LTN | DESCRIPTION   | DATE      | OWN | APVD |
|     |      | A         |     | RELEASED      | 30APR2013 | RK  | GB   |
|     |      | B         |     | ECR-17-005419 | 13APR2017 | TB  | TE   |
|     |      | C         |     | ECR-18-017030 | 28OC12018 | TB  | CT   |
|     |      | D         |     | ECR-21-120357 | 09NOV2021 | JWC | TE   |

|   |     |     |             |                                     |         |
|---|-----|-----|-------------|-------------------------------------|---------|
| - | 1   | 1   | 2119641-1   | FEED CAM, AIR FEED                  | 248     |
| - | 1   | 1   | 2119082-9   | CAM, SNAIL, INSULATION ADJUSTMENT   | 244     |
| - | 1   | 1   | 2079764-1   | WASHER, WAVE SPRING, CREST-TO-CREST | 243     |
| - | 1   | 1   | 2119083-1   | RETAINER, INSULATION DIAL           | 242     |
| - | 1   | 1   | 2844940-4   | AIR FEED MODULE                     | 238     |
| - | 1   | 1   | 1-18028-0   | WASHER, FLAT, REG M8                | 192     |
| - | 1   | 1   | 6-993111-6  | PIN, SLOTTED SPRING 3.0 X 14.0      | 177     |
| - | 1   | 1   | 8-22280-7   | SPRING, COMPRESSION                 | 176     |
| - | 1   | 1   | 1752353-2   | GUIDE PIN,HOLDDOWN                  | 175     |
| - | 1   | 1   | 1901680-2   | GUIDE PIN,HOLDDOWN                  | 174     |
| - | REF | REF | 994970-2    | COUNTER, MAGNETIC                   | 164     |
| - | 1   | 1   | 455888-6    | SPACER, CRIMPER                     | 82      |
| - | 1   | 1   | 2119791-5   | DEPRESSOR, WIRE                     | 73      |
| - | 1   | 1   | 1803607-4   | DOCUMENTATION PACKAGE               | 71      |
| - | 2   | 2   | 2-18032-2   | SCR, SET, FLT PNT, M3 X 10.0        | 70      |
| - | 1   | 1   | 2119943-1   | WASHER, SPACER                      | 69      |
| - | 1   | 1   | 2119740-1   | TAG, IDENTIFICATION                 | 67      |
| - | 2   | 2   | 2168078-1   | SCREW, DRIVE, RH, RoHS, 2 x .188    | 66      |
| - | 1   | 1   | 1901681-9   | HOLDDOWN, TERMINAL                  | 65      |
| - | 2   | 2   | 2168400-8   | SHCS, LOW HEAD, RoHS, M4 X 16       | 64      |
| - | 1   | 1   | 2168083-2   | SCR, SKT HD CAP, RoHS, M4 X 8.0     | 60      |
| - | 1   | 1   | 5-18022-5   | SCR, HEX HD CAP, M4 X 6.0           | 59      |
| - | 3   | 3   | 2168400-4   | SHCS, LOW HEAD, RoHS, M4 X 8        | 57      |
| - | 2   | 2   | 2168083-8   | SCR, SKT HD CAP, RoHS, M4 X 16      | 56      |
| - | 2   | 2   | 5018030-1   | NUT, HEX, REG, RoHS, M3             | 54      |
| - | 2   | 2   | 986965-8    | NUT, LOCK, HEX, TORQUE (M4)         | 53      |
| - | 1   | 1   | 1-5018030-0 | NUT, HEX, REG, RoHS, M3.5           | 52      |
| - | 1   | 1   | 2063961-1   | FEED FINGER                         | 51      |
| - | 1   | 1   | 1-1752354-6 | STANDOFF,HOLD-DOWN                  | 50      |
| - | 1   | 1   | 18023-9     | SCR, SKT HD CAP M4 X 6.0            | 49      |
| - | 1   | 1   | 2119655-5   | APPLICATOR BASIC ASSEMBLY, EF       | 46      |
| - | 1   | 1   | 1803517-1   | RAM ASSEMBLY, EF ATLANTIC           | 44      |
| - | 1   | 1   | 1803602-1   | SCR, BHSC, RoHS (M8 X 25)           | 41      |
| - | 7   | 7   | 1-18028-2   | WASHER, FLAT, REG M4                | 33      |
| - | 2   | 2   | 2168083-9   | SCR, SKT HD CAP, RoHS, M4 X 20      | 31      |
| - | 2   | 2   | 2168083-2   | SCR, SKT HD CAP, RoHS, M4 X 8.0     | 29      |
| - | 1   | 1   | 690455-1    | STRIPPER, FRONT CASTING             | 27      |
| - | 2   | 2   | 1-2168083-5 | SCR, SKT HD CAP, RoHS, M4 X 30      | 25      |
| - | 1   | 1   | 1-1752371-4 | PLATE, STRIP GUIDE                  | 24      |
| - | 1   | 1   | 240825-5    | PLATE, STRIP HOLD DOWN              | 23      |
| - | 2   | 2   | 22281-7     | SPRING, COMPRESSION                 | 22      |
| - | 1   | 1   | 1803292-4   | DRAG                                | 20      |
| - | 2   | 2   | 1901259-7   | GUIDE, LOWER STRIP                  | 18      |
| - | 4   | 4   | 1-2079383-1 | SCR, BHSC, RoHS (M6 X 12)           | 17      |
| - | 1   | 1   | 4-240641-7  | SPACER                              | 16      |
| - | 1   | 1   | 1752360-1   | SPACER,HOLD-DOWN                    | 13      |
| - | 1   | 1   | 1-240833-3  | PLATE, REAR SHEAR                   | 11      |
| - | -   | -   | -           | -                                   | 10      |
| - | 1   | 1   | 5-690482-4  | PLATE, FRONT SHEAR                  | 9       |
| - | 1   | 2   | 1333223-3   | ANVIL, COMBINATION                  | 8       |
| - | 1   | 1   | 2217206-4   | BLADE, SLUG                         | 7       |
| - | -   | -   | -           | -                                   | 6       |
| - | 1   | 1   | 1-240641-6  | SPACER                              | 5       |
| - | 1   | 1   | 3-238011-1  | BLOCK, CRIMPER SPACER               | 4       |
| - | 1   | 2   | 2-1633961-2 | CRIMPER, INSULATION F PREMIUM       | 3       |
| - | 1   | 1   | 1-455888-2  | SPACER, CRIMPER                     | 2       |
| - | 1   | 2   | 456428-3    | CRIMPER, WIRE                       | 1       |
| - | 77  | 72  | -2          | PART NO                             | ITEM NO |

ATLANTIC VERSION  
Shown on sheets 1 of 4 & 2 of 4  
(Pacific version shown on sheets 3 of 4 & 4 of 4)

|                |  |  |  |  |                                     |                                   |  |  |  |
|----------------|--|--|--|--|-------------------------------------|-----------------------------------|--|--|--|
| DIMENSIONS: mm |  | TOLERANCES UNLESS OTHERWISE SPECIFIED: |  | OWN<br>R. HUANG<br>CHK<br>L. ZHANG<br>APVD<br>J. GUO | 25MAR2013<br>25MAR2013<br>25MAR2013 | NAME<br>Ocean End Feed Applicator |  | TE Connectivity<br>Harrisburg, PA 17105-3608 |  |
| MATERIAL       |  | FINISH                                 |  | APPLICATION SPEC                                     |                                     | SIZE CAGE CODE DRAWING NO         |  | RESTRICTED TO                                |  |
|                |  |  |  | WEIGHT   |                                     | A1 00779 C=2150321                |  | Customer Accessible Production Drawing       |  |
|                |  |  |  | SCALE  |                                     | 1:1                               |  | SHEET 1 of 4 REV D                           |  |

| LOC | DIST | REVISIONS   |      |     |      |
|-----|------|-------------|------|-----|------|
| P   | LTN  | DESCRIPTION | DATE | DWN | APVD |
| A   | 66   | SEE SHEET 1 | -    | -   | -    |

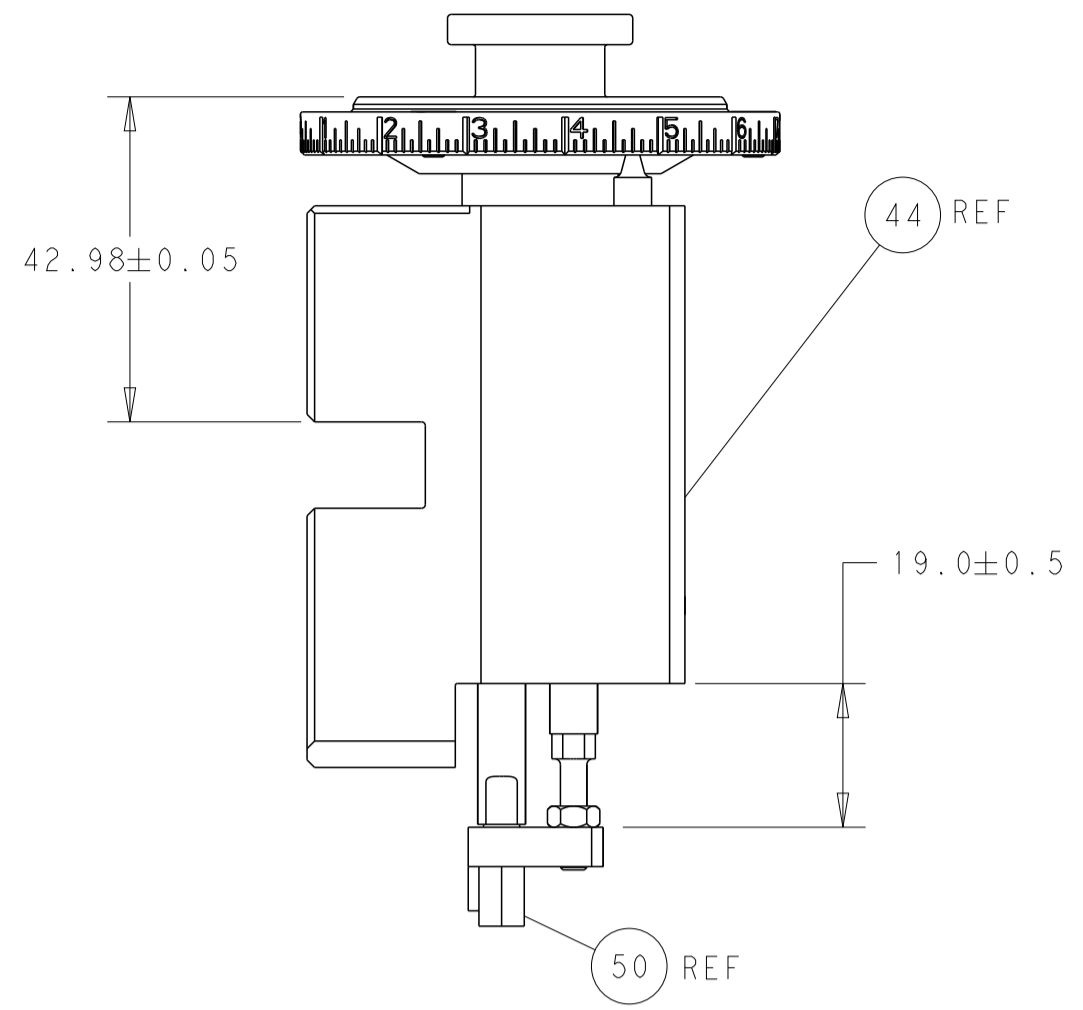

RAM AND HOLD DOWN SET-UP

FEED TYPE

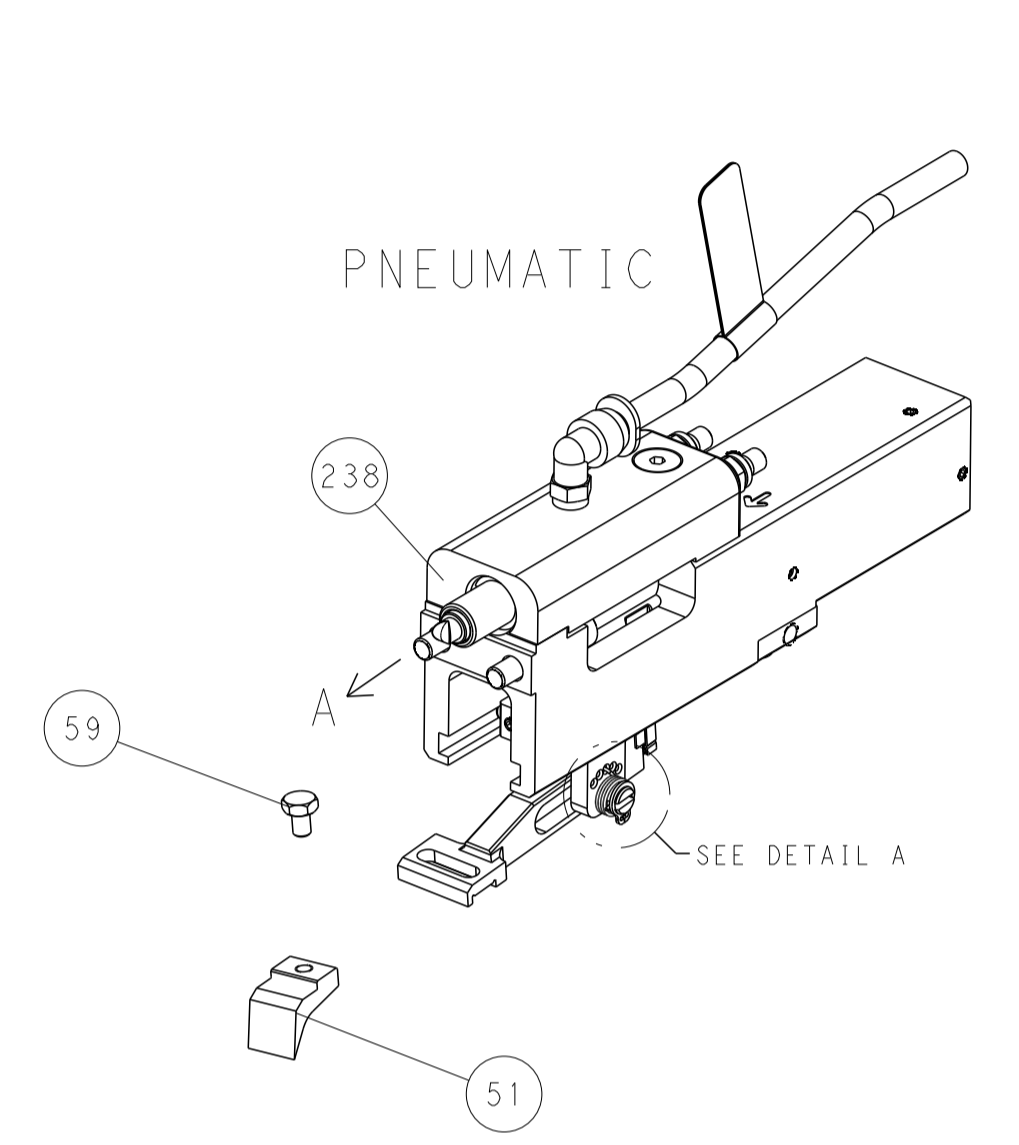

FEED SPRING SETTING POSITION

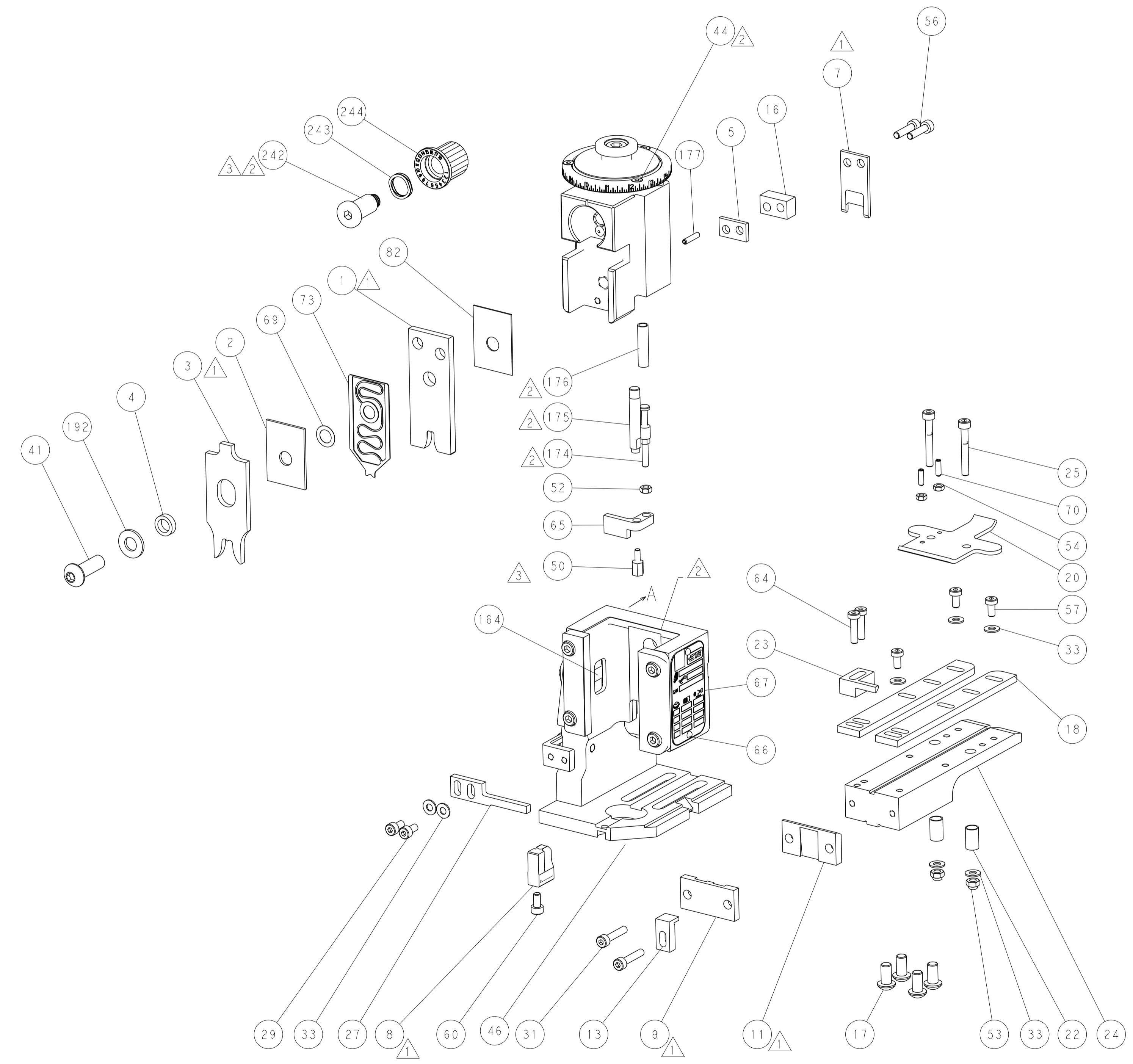
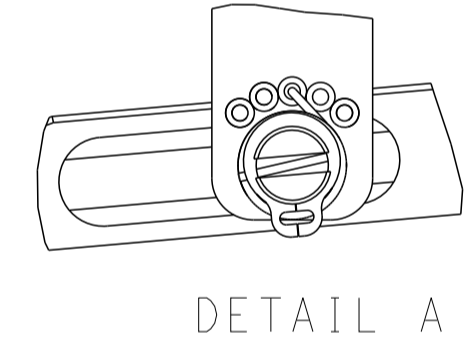

CAM POSITION

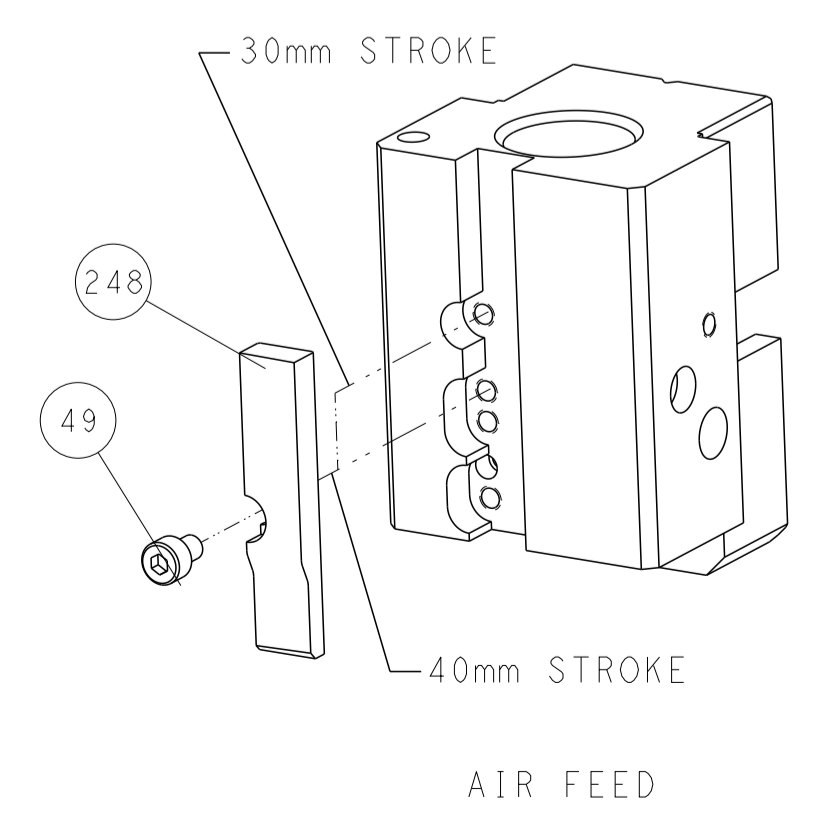

AIR FEED

ATLANTIC VERSION  
 Shown on sheets 1 of 4 & 2 of 4  
 (Pacific version shown on sheets 3 of 4 & 4 of 4)

|   |  |   |   |
|---|--|---|---|
| <small>THIS DRAWING IS UNPUBLISHED. RELEASED FOR PUBLICATION BY TYCO ELECTRONICS CORPORATION. ALL RIGHTS RESERVED.</small>            |  | DWN: K. HUANG 25MAR2013<br>CHK: L. ZHANG 25MAR2013<br>APVD: J. GUO 25MAR2013  | TE Connectivity<br>Harrisburg, PA 17105-3608            |
| DIMENSIONS: mm<br>TOLERANCES UNLESS OTHERWISE SPECIFIED:<br>0 PLC ±<br>1 PLC ±<br>2 PLC ±<br>3 PLC ±<br>4 PLC ±<br>ANGLES ±<br>FINISH |  | NAME: Ocean End Feed Applicator<br>PRODUCT SPEC:<br>APPLICATION SPEC:<br>SIZE: A1<br>CAGE CODE: 00779<br>DRAWING NO: C=2150321<br>WEIGHT: | RESTRICTED TO:<br>SCALE: 1:1<br>SHEET: 2 of 4<br>REV: D |
| MATERIAL:   |  | Customer Accessible Production Drawing  |   |

| THIS DRAWING IS UNPUBLISHED.                                       | RELEASED FOR PUBLICATION |                          |           |
|--|--------------------------|--------------------------|-----------|
| COPYRIGHT 20 BY TYCO ELECTRONICS CORPORATION. ALL RIGHTS RESERVED. |                          |                          |           |
| PART NUMBER  | REVISION                 | DESCRIPTION              | FEED TYPE |
| 2-2150321-2  | D                        | FINE CRIMP HEIGHT ADJUST | PNEUMATIC |
| 7-2150321-7  | A                        | CRIMP TOOLING KIT        | -         |

PACIFIC VERSION TERMINATOR  
INTERFACE ADAPTER

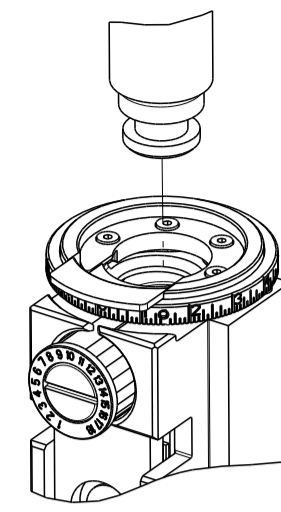

| APPLICATOR DATA                      |                  |      |
|--------------------------------------|------------------|------|
| CRIMP                                | SIZE             | TYPE |
| WIRE                                 | 4.57 mm [ .180 ] | F    |
| INSUL                                | 7.62 mm [ .300 ] | F    |
| APPLICATOR INSTRUCTIONS<br>408-35043 |                  |      |

|   |             |   |             |
|---|-------------|---|-------------|
| TERMINAL DATA: TE TERMINAL                          |             | TE CRIMP SPECIFICATION                                      |             |
| TERMINAL NAME: .375 SERIES FASTIN-FASTON RECEPTACLE |             |   |             |
| WIRE STRIP LENGTH<br>6.22-6.99 mm [ .245-.275 IN ]  |             | INSULATION DIAMETER RANGE<br>Ø5.08-6.99 mm [ .200-.275 IN ] |             |
| TERMINAL APPLICATION SPECIFICATION                  | 114-20021   | -   | -           |
| TERMINALS APPLIED                                   |             |   |             |
| TE TERMINAL   | TE TERMINAL | TE TERMINAL   | TE TERMINAL |
| 280755-2  | 280755-4    | 281091-2  |             |

| WIRE SIZE          | CRIMP HEIGHT mm [INCH]       | CRIMP HEIGHT REFERENCE SETTING |
|--------------------|------------------------------|--------------------------------|
| 10.00mm2           | 3.63+/-0.05 [ .143+/- .002 ] | 4.9                            |
| 6.0+2.5 or 8.50mm2 | 3.51+/-0.05 [ .138+/- .002 ] | 6.3                            |
| 8.00mm2            | 3.43+/-0.05 [ .135+/- .002 ] | 7.4                            |
| 6.00mm2            | 3.23+/-0.05 [ .127+/- .002 ] | 8.6                            |

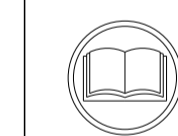

- RECOMMENDED SPARE PARTS
- REFER TO SUPPLIED INSTRUCTION SHEET FOR CLEANING, LUBRICATION AND STORAGE OF APPLICATOR.
- APPLY PART NUMBER 2-23419-6 LOCTITE TO THREADS OF ITEM 242. APPLY PART NUMBER 1-23419-5 LOCTITE TO THREADS OF ITEM 50.
- CRIMP HEIGHT REFERENCE SETTING WAS THE SETTING USED WHEN THE APPLICATOR WAS QUALIFIED AT THE FACTORY. ADJUSTMENT MAY BE NECESSARY WHEN RUNNING APPLICATOR IN THE FIELD.
- TERMINAL PITCH NOT COMPATIBLE WITH MECHANICAL FEED.
- UNLESS SPECIFIED OTHERWISE TORQUE VALUES SHALL BE USED PER DOCUMENT, 101-35000.

**\*WARNING**  
ON INSTALLATION, SET WIRE DISC TO CRIMP HEIGHT REFERENCE SETTING FOR LARGEST WIRE SIZE. CRIMP HEIGHT REFERENCE SETTINGS GREATER THAN THE VALUE SHOWN MAY CAUSE DAMAGE TO THE CRIMP TOOLING. REFER TO THE INSTRUCTION SHEET FOR PROPER SETUP AND ADJUSTMENTS.

PACIFIC VERSION  
Shown on sheets 3 of 4 & 4 of 4  
(Atlantic version shown on sheets 1 of 4 & 2 of 4)

| LOC | DIST | REVISIONS |     |             |      |     |      |
|-----|------|-----------|-----|-------------|------|-----|------|
| A   | 66   | P         | LTN | DESCRIPTION | DATE | OWN | APVD |
|     |      | -         |     | SEE SHEET 1 | -    | -   | -    |

|   |     |             |                                     |     |
|---|-----|-------------|-------------------------------------|-----|
| - | 1   | 2119082-9   | CAM, SNAIL, INSULATION ADJUSTMENT   | 244 |
| - | 1   | 2079764-1   | WASHER, WAVE SPRING, CREST-TO-CREST | 243 |
| - | 1   | 2119083-1   | RETAINER, INSULATION DIAL           | 242 |
| - | 1   | 2844940-4   | AIR FEED MODULE                     | 238 |
| - | 1   | 1-18028-0   | WASHER, FLAT, REG M8                | 192 |
| - | 4   | 2079383-9   | SCR, BHSC, RoHS (M6 X 20)           | 186 |
| - | 1   | 6-993111-6  | PIN, SLOTTED SPRING 3.0 X 14.0      | 177 |
| - | 1   | 8-22280-7   | SPRING, COMPRESSION                 | 176 |
| - | 1   | 1752353-2   | GUIDE PIN, HOLDDOWN                 | 175 |
| - | 1   | 1901680-2   | GUIDE PIN, HOLDDOWN                 | 174 |
| - | REF | 994970-2    | COUNTER, MAGNETIC                   | 164 |
| - | 1   | 2119641-2   | FEED CAM, AIR FEED                  | 152 |
| - | 1   | 2168083-8   | SCR, SKT HD CAP, RoHS, M4 X 16      | 144 |
| - | 1   | 2119655-6   | APPLICATOR BASIC ASSEMBLY, EF       | 141 |
| - | 1   | 1803518-1   | RAM ASSEMBLY, EF PACIFIC            | 140 |
| - | 1   | 455888-6    | SPACER, CRIMPER                     | 82  |
| - | 1   | 2119791-5   | DEPRESSOR, WIRE                     | 73  |
| - | 1   | 1803607-4   | DOCUMENTATION PACKAGE               | 71  |
| - | 2   | 2-18032-2   | SCR, SET, FLT PNT, M3 X 10.0        | 70  |
| - | 1   | 2119943-1   | WASHER, SPACER                      | 69  |
| - | 1   | 2119740-1   | TAG, IDENTIFICATION                 | 67  |
| - | 2   | 2168078-1   | SCREW, DRIVE, RH, RoHS, 2 x .188    | 66  |
| - | 1   | 1901681-9   | HOLDDOWN, TERMINAL                  | 65  |
| - | 2   | 2168400-8   | SHCS, LOW HEAD, RoHS, M4 X 16       | 64  |
| - | 1   | 5-18022-5   | SCR, HEX HD CAP, M4 X 6.0           | 59  |
| - | 3   | 2168400-4   | SHCS, LOW HEAD, RoHS, M4 X 8        | 57  |
| - | 2   | 2168083-8   | SCR, SKT HD CAP, RoHS, M4 X 16      | 56  |
| - | 2   | 5018030-1   | NUT, HEX, REG, RoHS, M3             | 54  |
| - | 2   | 986965-8    | NUT, LOCK, HEX, TORQUE (M4)         | 53  |
| - | 1   | 1-5018030-0 | NUT, HEX, REG, RoHS, M3.5           | 52  |
| - | 1   | 2063961-1   | FEED FINGER                         | 51  |
| - | 1   | 1-1752354-6 | STANDOFF, HOLD-DOWN                 | 50  |
| - | 1   | 18023-9     | SCR, SKT HD CAP M4 X 6.0            | 49  |
| - | 1   | 1803602-1   | SCR, BHSC, RoHS (M8 X 25)           | 41  |
| - | 7   | 1-18028-2   | WASHER, FLAT, REG M4                | 33  |
| - | 2   | 2168083-9   | SCR, SKT HD CAP, RoHS, M4 X 20      | 31  |
| - | 2   | 2168083-2   | SCR, SKT HD CAP, RoHS, M4 X 8.0     | 29  |
| - | 1   | 690455-1    | STRIPPER, FRONT CASTING             | 27  |
| - | 2   | 1-2168083-5 | SCR, SKT HD CAP, RoHS, M4 X 30      | 25  |
| - | 1   | 1-1752371-4 | PLATE, STRIP GUIDE                  | 24  |
| - | 1   | 240825-5    | PLATE, STRIP HOLD DOWN              | 23  |
| - | 2   | 22281-7     | SPRING, COMPRESSION                 | 22  |
| - | 1   | 1803292-4   | DRAG                                | 20  |
| - | 2   | 1901259-7   | GUIDE, LOWER STRIP                  | 18  |
| - | 1   | 4-240641-7  | SPACER                              | 16  |
| - | 1   | 1752360-1   | SPACER, HOLD-DOWN                   | 13  |
| - | 1   | 1-240833-3  | PLATE, REAR SHEAR                   | 11  |
| - | -   | -           | -                                   | 10  |
| - | 1   | 5-690482-4  | PLATE, FRONT SHEAR                  | 9   |
| 1 | 1   | 1333223-3   | ANVIL, COMBINATION                  | 8   |
| - | 1   | 2217206-4   | BLADE, SLUG                         | 7   |
| - | -   | -           | -                                   | 6   |
| - | 1   | 1-240641-6  | SPACER                              | 5   |
| - | 1   | 3-238011-1  | BLOCK, CRIMPER SPACER               | 4   |
| 1 | 1   | 2-1633961-2 | CRIMPER, INSULATION F PREMIUM       | 3   |
| - | 1   | 1-455888-2  | SPACER, CRIMPER                     | 2   |
| 1 | 1   | 456428-3    | CRIMPER, WIRE                       | 1   |

|                |  |  |  |                         |  |                         |  |                        |  |                                 |  |
|----------------|--|--|--|-------------------------|--|-------------------------|--|------------------------|--|---------------------------------|--|
| DIMENSIONS: mm |  | TOLERANCES UNLESS OTHERWISE SPECIFIED: |  | DWN: R. HUANG 25MAR2013 |  | CHK: L. ZHANG 25MAR2013 |  | APVD: J. GUO 25MAR2013 |  | NAME: Ocean End Feed Applicator |  |
| 0 PLC ±        |  | 1 PLC ±                                |  | 2 PLC ±                 |  | 3 PLC ±                 |  | 4 PLC ±                |  | SIZE: A1                        |  |
| ANGLES         |  | FINISH                                 |  | WEIGHT                  |  | CAGE CODE               |  | DRAWING NO             |  | RESTRICTED TO                   |  |
| MATERIAL       |  | FINISH                                 |  | WEIGHT                  |  | CAGE CODE               |  | DRAWING NO             |  | RESTRICTED TO                   |  |
| -              |  | -                                      |  | -                       |  | 00779                   |  | 2150321                |  | -                               |  |
| -              |  | -                                      |  | -                       |  | -                       |  | -                      |  | -                               |  |

| LOC | DIST | REVISIONS   |      |     |      |
|-----|------|-------------|------|-----|------|
| P   | LTN  | DESCRIPTION | DATE | DMN | APVD |
| A   | 66   | SEE SHEET 1 |      |     |      |

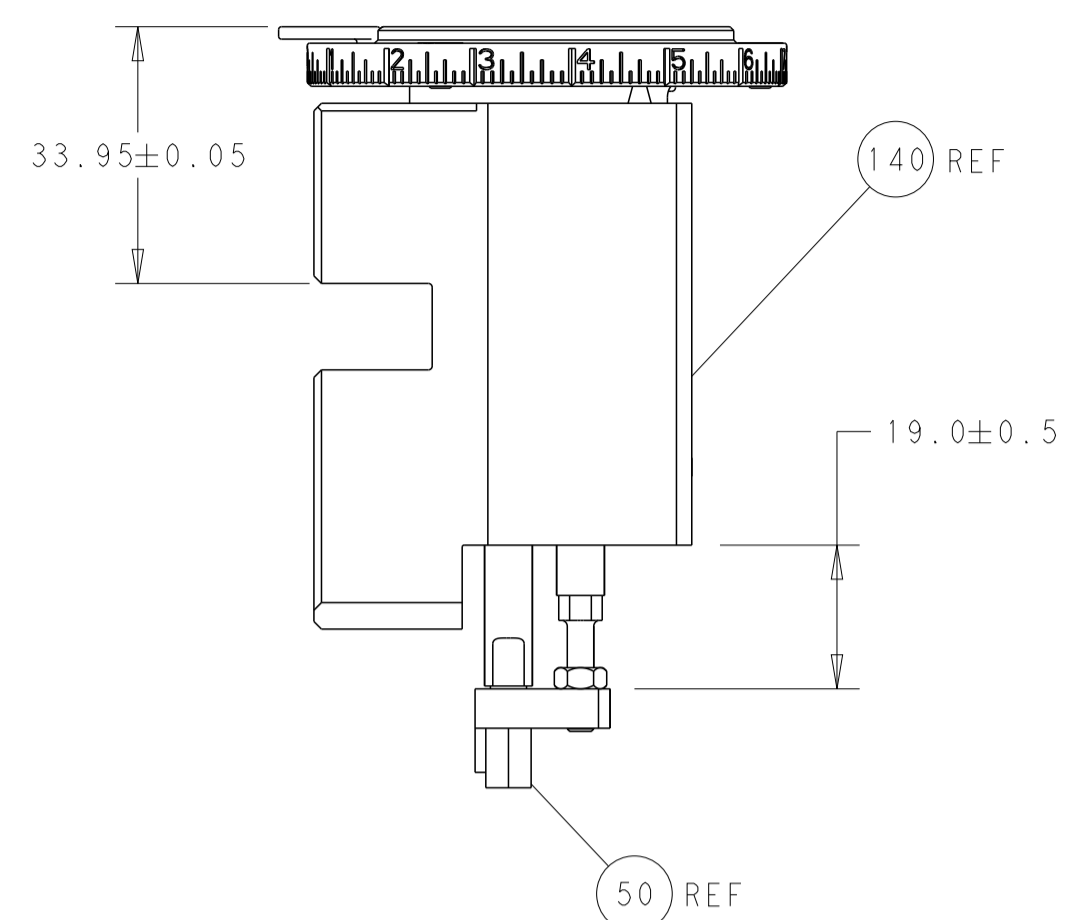

RAM AND HOLD DOWN SET-UP

FEED TYPE

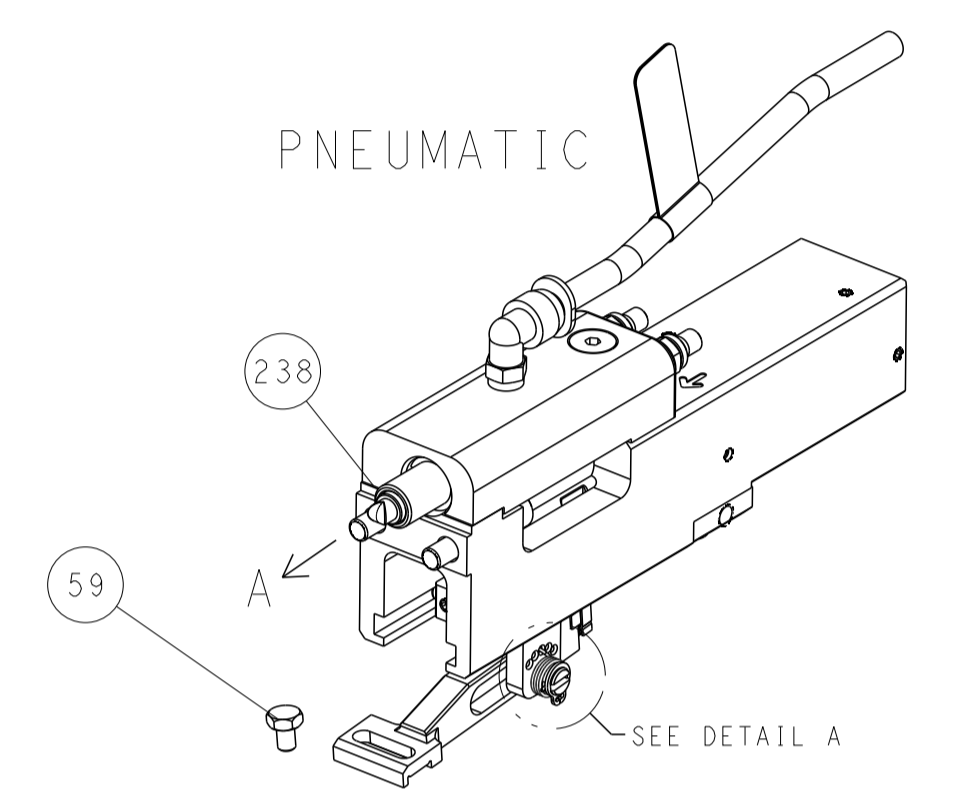

FEED SPRING SETTING POSITION

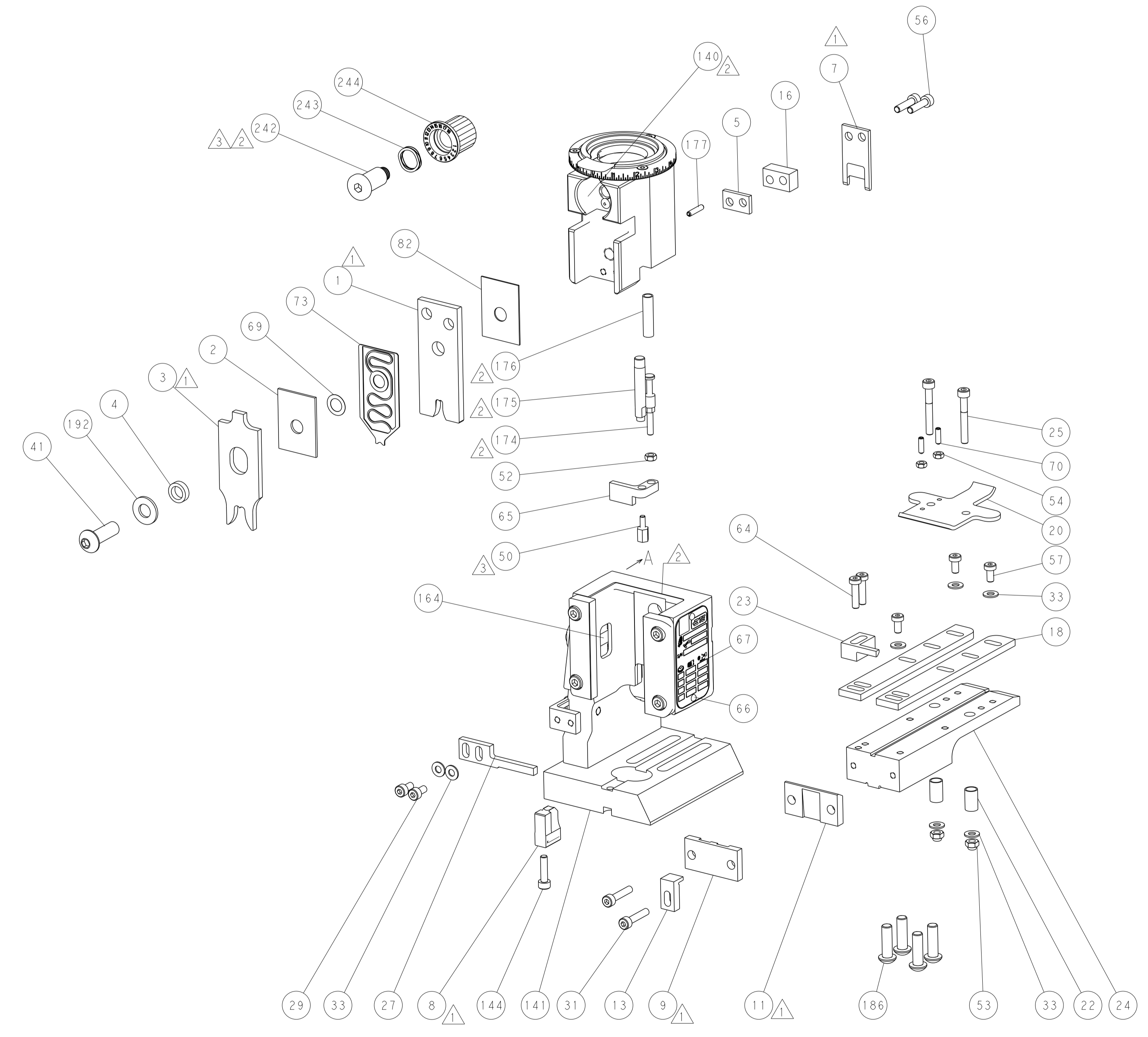
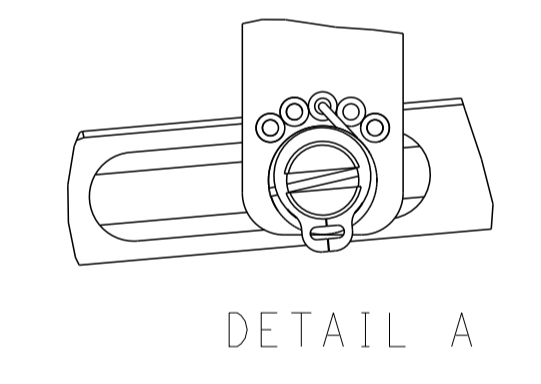

CAM POSITION

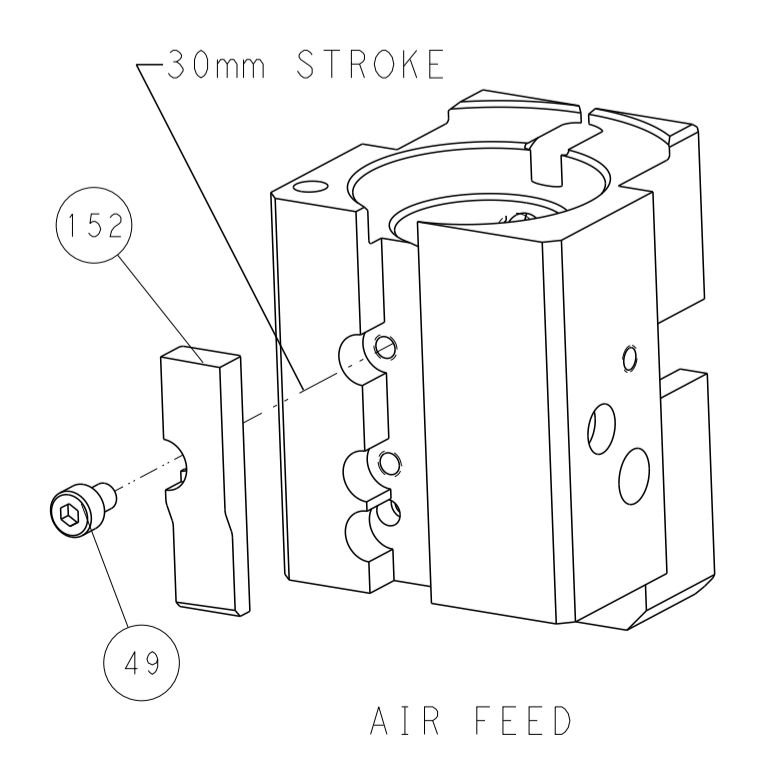

PACIFIC VERSION  
 Shown on sheets 3 of 4 & 4 of 4  
 (Atlantic version shown on sheets 1 of 4 & 2 of 4)

|   |  |   |  |
|---|--|---|--|
| <small>THIS DRAWING IS UNPUBLISHED. RELEASED FOR PUBLICATION. ALL RIGHTS RESERVED.</small><br><small>TYCO ELECTRONICS CORPORATION</small>               |  | DWN: K. HUANG 25MAR2013<br>CHK: L. ZHANG 25MAR2013<br>APVD: J. GUO 25MAR2013  | TE Connectivity<br>Harrisburg, PA 17105-3608 |
| DIMENSIONS: mm<br>TOLERANCES UNLESS OTHERWISE SPECIFIED:<br>0 PLC ±<br>1 PLC ±<br>2 PLC ±<br>3 PLC ±<br>4 PLC ±<br>ANGLES ±<br>MATERIAL: -<br>FINISH: - |  | NAME: Ocean End Feed Applicator<br>SIZE: A1<br>CAGE CODE: 00779<br>DRAWING NO: C=2150321<br>SCALE: 1:1<br>SHEET: 4 OF 4<br>REV: D | RESTRICTED TO: -                             |
| CUSTOMER ACCESSIBLE PRODUCTION DRAWING  |  | SHEETS 1 & 2 ARE NOT REQUIRED FOR PACIFIC VERSION   |  |