

### DESCRIPTION

The MP3387L is a step-up converter with 6-channel current sources. It is designed for driving the white LED arrays as backlighting of small or middle size LCD panel.

The MP3387L uses peak-current mode as its PWM control architecture. The switching frequency can be programmed by a resistor. It generates an output voltage up to 45V from a 3V to 25V input supply. The MP3387L independently regulates the current in each LED string to the value set by an external current-setting resistor.

The MP3387L applies 6 internal current sources in each LED string terminal to achieve a current balance with 3% current regulation accuracy between strings. Its low 500mV regulation voltage on LED current sources reduces power loss.

The MP3387L features external digital PWM dimming and analog dimming, both of which sharing a single input with 25% PWM duty cycle as a transfer point. The mix-dimming strategy helps to improve the dimming ratio. Also, MP3387L automatically transfers the PWM input signal 100Hz to 20kHz frequency to 24kHz to 27.5kHz to eliminate the audible noise.

MP3387L has rich protection modes to guarantee safety operation. The protection modes include recoverable OCP (over-current protection), OVP (over-voltage protection), OTP (over-temperature protection), any string of LED short and open protection.

The MP3387L is available in TQFN24-4mmX4mm package.

### ELECTRICAL SPECIFICATIONS

Parameter	Symbol	Value	Units
Input Voltage	$V_{IN}$	3 – 25	V
Output Voltage	$V_{LED}$	<50	V
LEDs #		6 string	

LED Current	$I_{LED}$	20/string	mA
-------------	-----------	-----------	----

### FEATURES

- 6-String, Max 45mA/String
- 3V to 25V Input Voltage Range
- 3% Current Matching Accuracy Between Strings
- Programmable Switching Frequency
- Selectable Combined Analog and PWM Dimming Mode or Pure PWM Dimming Mode
- Combined Analog and PWM Dimming Mode with 25% Dimming Transfer Point
- 24kHz to 27.5kHz Output Dimming Frequency to eliminate audible noise
- Cascading Capability with a Single Power Source
- Programmable Over-Voltage Protection
- Recoverable Thermal Shutdown Protection
- Cycle by Cycle Over Current Protection
- Under-Voltage Lockout
- TQFN24 (4X4mm) Package

### APPLICATIONS

- Notebook PC
- Tablet Computer
- Handy Terminals Display
- Automotive System

All MPS parts are lead-free and adhere to the RoHS directive. For MPS green status, please visit MPS website under Products, Quality Assurance page. "MPS" and "The Future of Analog IC Technology" are registered trademarks of Monolithic Power Systems, Inc.

### EV3387L-RT-00A EVALUATION BOARD

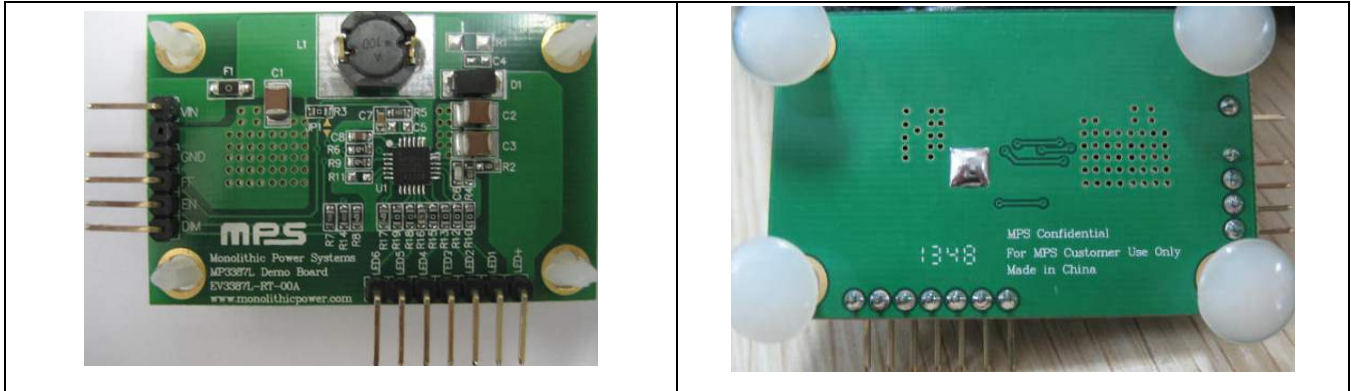

(L x W x H) 5cm x 3.2cm x 1.0cm

Board Number	MPS IC Number
EV3387L-RT-00A	MP3387LGRT

### EVALUATION BOARD SCHEMATIC

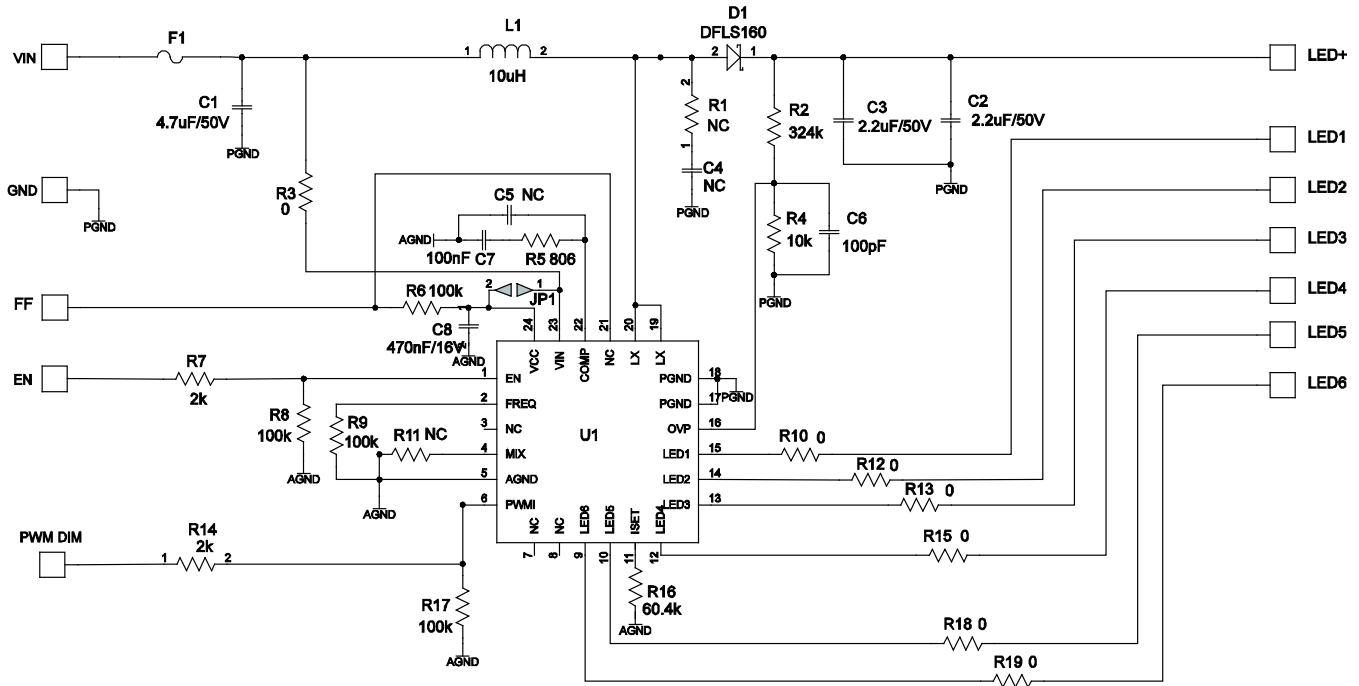

**EV3387L-RT-00A BILL OF MATERIALS**

Qty	Ref	Value	Description	Package	Manufacturer	Part Number
1	C1	4.7 $\mu$ F	Ceramic Capacitor, 50V, X7R	1210	Murata	GRM32ER71H475KA8
2	C2,C3	2.2 $\mu$ F	Ceramic Capacitor, 50V, X7R	1210	Murata	GRM32ER72A225KA3
1	C4	NC				
1	C5	NC				
1	C6	100pF	Ceramic Capacitor, 50V	0603	Murata	GRM1885C1H101JA01D
1	C7	100nF	Ceramic Capacitor, 16V, X7R	0603	Murata	GCJ188R71H104KA12D
1	C8	0.47 $\mu$ F	Ceramic Capacitor, 16V, X5R	0603	Murata	GRM188R71C47KA88D
1	D1	B160	Diode Schottky, 60V, 1A	SMA	Diodes Inc	B160
1	L1	10 $\mu$ H	Inductor,2.7A	SMD	SUMIDA	DS84LCB-B1134AS-100M
1	F1	0 $\Omega$	Resistor, 1%	1206	Yageo	RC1206JR-070RL
1	R1	NC				
1	R2	324k $\Omega$	Resistor, 1%	0603	Yageo	RC0603FR-07324KL
1	R3	0 $\Omega$	Resistor, 1%	0603	Yageo	RC0603JR-070RL
1	R4	10k $\Omega$	Resistor, 1%	0603	Yageo	RC0603FR-0710KL
1	R5	806 $\Omega$	Resistor, 1%	0603	Yageo	RC0603FR-07806RL
4	R6,R9,R8,R17	100k $\Omega$	Resistor, 1%	0603	Yageo	RC0603JR-07100KL
2	R7,R14	2k $\Omega$	Resistor, 5%	0603	Yageo	RC0603JR-0702KL
6	R10,R12-R15,R18,R19	0 $\Omega$	Resistor, 1%	0603	Yageo	RC0603JR-070RL
1	R11	NC				
1	R16	60.4k $\Omega$	Resistor, 1%	0603	Yageo	RC0603FR-0760K4L
1	U1		LED Driver IC	QFN24	MPS	MP3387L

## EVB TEST RESULTS

Performance waveforms are tested on the evaluation board.

$V_{IN} = 12V$ , 10 LEDs in series, 6 strings parallel, 20mA/string,  $T_A = 25^\circ C$ , unless otherwise noted.

### Efficiency

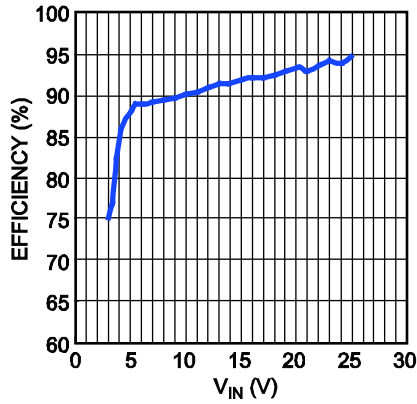

### Steady State

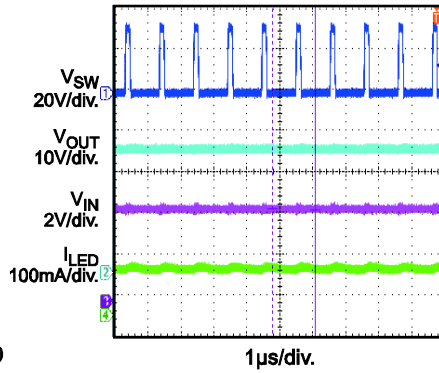

### $V_{IN}$ Power On

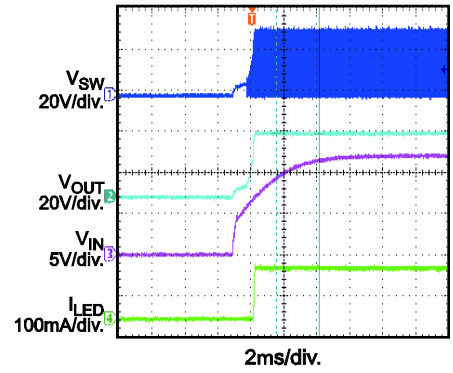

### EN Power On

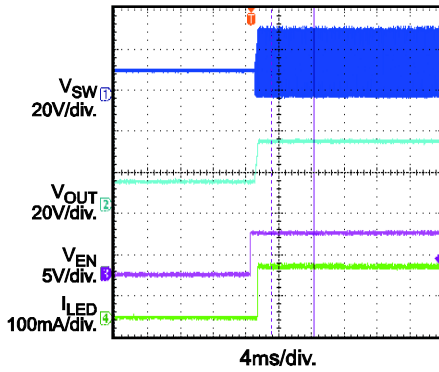

### Dimming in Mix Mode

$f_{PWM} = 2kHz$ ,  $D_{PWM} = 10\%$

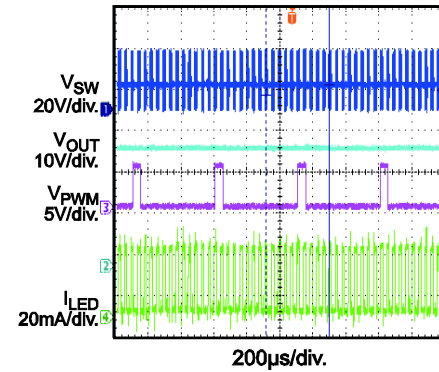

### Dimming in Mix Mode

$f_{PWM} = 2kHz$ ,  $D_{PWM} = 50\%$

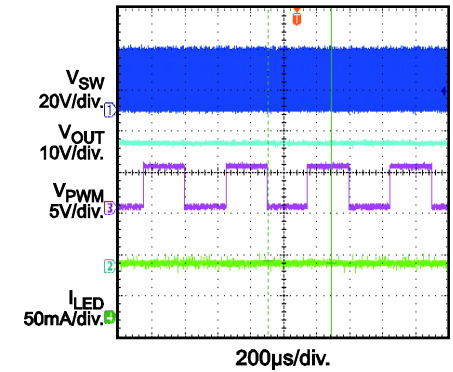

### Dimming in External PWM Mode

$f_{PWM} = 2kHz$ ,  $D_{PWM} = 50\%$

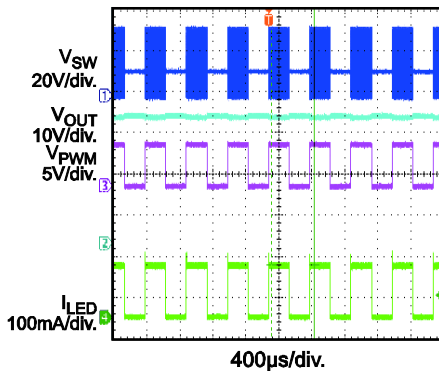

### Open LED Protection

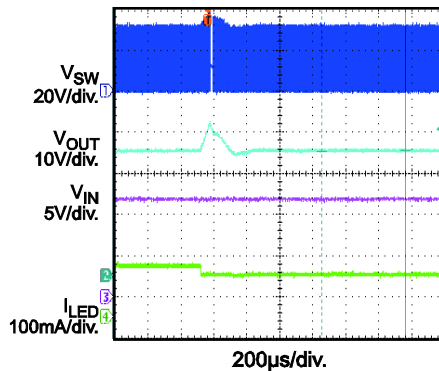

### Short LED Protection

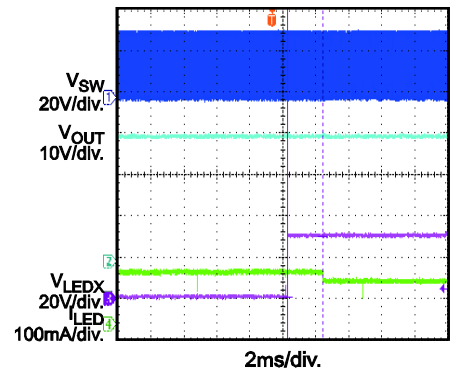

### PRINTED CIRCUIT BOARD LAYOUT

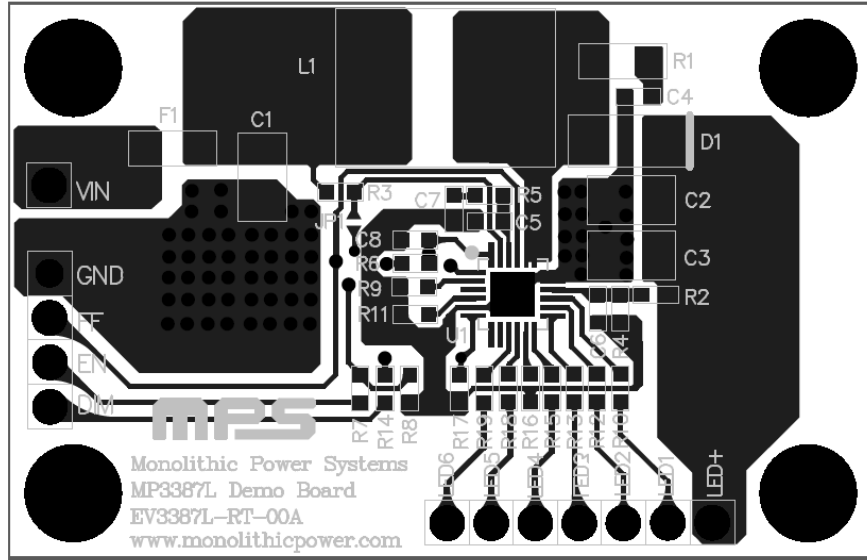

Figure 1—Top Layer

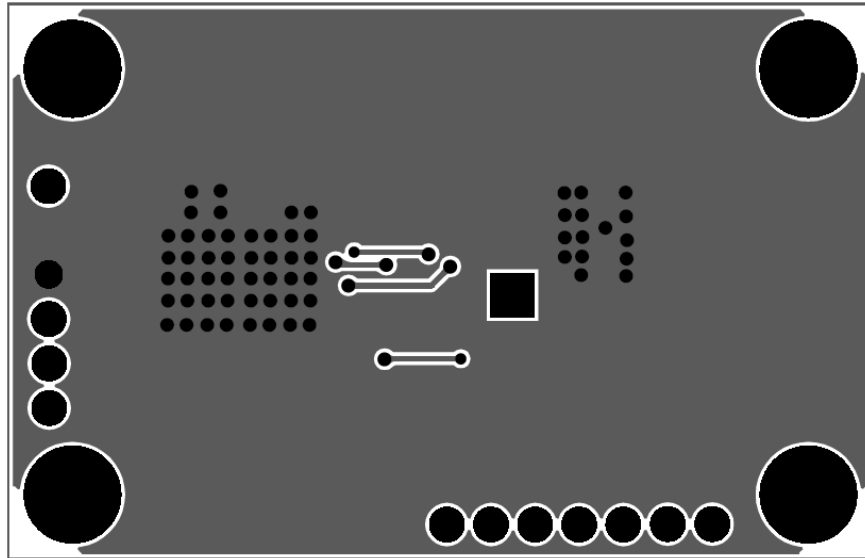

Figure 2—Bottom Layer

## QUICK START GUIDE

1. Connect the positive and negative terminals of the load panel (6 strings) to the LED+ and LED1~6 pins on the EV board, respectively.
2. Connect the positive and negative terminals of the power supply (3V ~ 25V) to the VIN and GND pins on the EV board, respectively.
3. Drive EN pin high (5V) to enable the MP3387L
4. Drive PWM DIM pin with 200Hz~20kHz pulse signal, the dim duty is low to 1% in Mix dim mode..
5. Mix dimming is default dimming for MP3387L. If need to apply direct PWM dimming, connect the mix pin to GND by resistor R11(0ohm).
6. Set current of every string by R16 .
7. Connect VCC and VIN together through JP1 if VIN is below 5V.

**NOTICE:** The information in this document is subject to change without notice. Please contact MPS for current specifications. Users should warrant and guarantee that third party Intellectual Property rights are not infringed upon when integrating MPS products into any application. MPS will not assume any legal responsibility for any said applications.