

BFP720

Low Noise Silicon Germanium Bipolar RF Transistor

Data Sheet

Revision 1.1, 2012-10-19

Edition 2012-10-19

**Published by
Infineon Technologies AG
81726 Munich, Germany**

**© 2013 Infineon Technologies AG
All Rights Reserved.**

Legal Disclaimer

The information given in this document shall in no event be regarded as a guarantee of conditions or characteristics. With respect to any examples or hints given herein, any typical values stated herein and/or any information regarding the application of the device, Infineon Technologies hereby disclaims any and all warranties and liabilities of any kind, including without limitation, warranties of non-infringement of intellectual property rights of any third party.

Information

For further information on technology, delivery terms and conditions and prices, please contact the nearest Infineon Technologies Office (www.infineon.com).

Warnings

Due to technical requirements, components may contain dangerous substances. For information on the types in question, please contact the nearest Infineon Technologies Office.

Infineon Technologies components may be used in life-support devices or systems only with the express written approval of Infineon Technologies, if a failure of such components can reasonably be expected to cause the failure of that life-support device or system or to affect the safety or effectiveness of that device or system. Life support devices or systems are intended to be implanted in the human body or to support and/or maintain and sustain and/or protect human life. If they fail, it is reasonable to assume that the health of the user or other persons may be endangered.

BFP720, Low Noise Silicon Germanium Bipolar RF Transistor

Revision History: 2012-10-19, Revision 1.1

Page	Subjects (changes since previous revision)
	This data sheet replaces the revision from 2009-01-20. The product itself has not been changed and the device characteristics remain unchanged. Only the product description and information available in the data sheet have been expanded and updated.

Trademarks of Infineon Technologies AG

AURIX™, C166™, CanPAK™, CIPOS™, CIPURSE™, EconoPACK™, CoolMOS™, CoolSET™, CORECONTROL™, CROSSAVE™, DAVE™, DI-POL™, EasyPIM™, EconoBRIDGE™, EconoDUAL™, EconoPIM™, EconoPACK™, EiceDRIVER™, eupec™, FCOS™, HITFET™, HybridPACK™, I²RF™, ISOFACE™, IsoPACK™, MIPAQ™, ModSTACK™, my-d™, NovalithIC™, OptiMOS™, ORIGA™, POWERCODE™, PRIMARION™, PrimePACK™, PrimeSTACK™, PRO-SIL™, PROFET™, RASIC™, ReverSave™, SatRIC™, SIEGET™, SINDRION™, SIPMOS™, SmartLEWIS™, SOLID FLASH™, TEMPFET™, thinQ!™, TRENCHSTOP™, TriCore™.

Other Trademarks

Advance Design System™ (ADS) of Agilent Technologies, AMBA™, ARM™, MULTI-ICE™, KEIL™, PRIMECELL™, REALVIEW™, THUMB™, μVision™ of ARM Limited, UK. AUTOSAR™ is licensed by AUTOSAR development partnership. Bluetooth™ of Bluetooth SIG Inc. CAT-iq™ of DECT Forum. COLOSSUS™, FirstGPS™ of Trimble Navigation Ltd. EMV™ of EMVCo, LLC (Visa Holdings Inc.). EPCOS™ of Epcos AG. FLEXGO™ of Microsoft Corporation. FlexRay™ is licensed by FlexRay Consortium. HYPERTERMINAL™ of Hilgraeve Incorporated. IEC™ of Commission Electrotechnique Internationale. IrDA™ of Infrared Data Association Corporation. ISO™ of INTERNATIONAL ORGANIZATION FOR STANDARDIZATION. MATLAB™ of MathWorks, Inc. MAXIM™ of Maxim Integrated Products, Inc. MICROTEC™, NUCLEUS™ of Mentor Graphics Corporation. MIPI™ of MIPI Alliance, Inc. MIPS™ of MIPS Technologies, Inc., USA. muRata™ of MURATA MANUFACTURING CO., MICROWAVE OFFICE™ (MWO) of Applied Wave Research Inc., OmniVision™ of OmniVision Technologies, Inc. Openwave™ Openwave Systems Inc. RED HAT™ Red Hat, Inc. RFMD™ RF Micro Devices, Inc. SIRIUS™ of Sirius Satellite Radio Inc. SOLARIS™ of Sun Microsystems, Inc. SPANSION™ of Spansion LLC Ltd. Symbian™ of Symbian Software Limited. TAIYO YUDEN™ of Taiyo Yuden Co. TEAKLITE™ of CEVA, Inc. TEKTRONIX™ of Tektronix Inc. TOKO™ of TOKO KABUSHIKI KAISHA TA. UNIX™ of X/Open Company Limited. VERILOG™, PALLADIUM™ of Cadence Design Systems, Inc. VLYNQ™ of Texas Instruments Incorporated. VXWORKS™, WIND RIVER™ of WIND RIVER SYSTEMS, INC. ZETEX™ of Diodes Zetex Limited.

Last Trademarks Update 2011-11-11

Table of Contents

	Table of Contents	4
	List of Figures	5
	List of Tables	6
1	Product Brief	7
2	Features	8
3	Maximum Ratings	9
4	Thermal Characteristics	10
5	Electrical Characteristics	12
5.1	DC Characteristics	12
5.2	General AC Characteristics	12
5.3	Frequency Dependent AC Characteristics	13
5.4	Characteristic Curves	18
6	Simulation Data	23
7	Package Information SOT343	24

List of Figures

Figure 4-1	Total Power Dissipation $P_{\text{tot}} = f(T_s)$	10
Figure 4-2	Permissible Pulse Load $P_{\text{tot_max}} / P_{\text{tot_DC}} = f(t_p)$	11
Figure 4-3	Permissible Pulse Load $R_{\text{thJS}} = f(t_p)$	11
Figure 5-1	BFP720 Testing Circuit.	13
Figure 5-2	Transition Frequency $f_T = f(I_C, V_{CE}), f = 1 \text{ GHz}, V_{CE} = \text{Parameter in V}$	18
Figure 5-3	Power Gain $G_{\text{ma}}, G_{\text{ms}}, S_{21} ^2 = f(f), V_{CE} = 3 \text{ V}, I_C = 13 \text{ mA}$	18
Figure 5-4	Input Matching $S_{11} = f(f), V_{CE} = 3 \text{ V}, I_C = 5 \text{ mA} / 13 \text{ mA}$	19
Figure 5-5	Output Matching $S_{22} = f(f), V_{CE} = 3 \text{ V}, I_C = 5 \text{ mA} / 13 \text{ mA}$	19
Figure 5-6	Source Impedance Z_{opt} for $NF_{\text{min}} = f(f), V_{CE} = 3 \text{ V}, I_C = 5 \text{ mA} / 13 \text{ mA}$	20
Figure 5-7	Noise Figure $NF_{\text{min}} = f(I_C), V_{CE} = 3 \text{ V}, Z_S = Z_{\text{opt}}$	20
Figure 5-8	Noise Figure $NF_{\text{min}} = f(f), V_{CE} = 3 \text{ V}, Z_S = Z_{\text{opt}}$	21
Figure 5-9	Power Gain $G_{\text{ma}}, G_{\text{ms}} = f(I_C), V_{CE} = 3 \text{ V}, f = \text{Parameter in GHz}$	21
Figure 5-10	Power Gain $G_{\text{ma}}, G_{\text{ms}} = f(V_{CE}), I_C = 13 \text{ mA}, f = \text{Parameter in GHz}$	22
Figure 7-1	Package Outline	24
Figure 7-2	Package Footprint	24
Figure 7-3	Marking Description (Marking BFP720: R9s)	24
Figure 7-4	Tape Dimensions	24

List of Tables

Table 3-1	Maximum Ratings at $T_A = 25\text{ °C}$ (unless otherwise specified)	9
Table 4-1	Thermal Resistance	10
Table 5-1	DC Characteristics at $T_A = 25\text{ °C}$	12
Table 5-2	AC Characteristics at $T_A = 25\text{ °C}$	12
Table 5-3	AC Characteristics, $V_{CE} = 3\text{ V}$, $f = 150\text{ MHz}$	13
Table 5-4	AC Characteristics, $V_{CE} = 3\text{ V}$, $f = 450\text{ MHz}$	14
Table 5-5	AC Characteristics, $V_{CE} = 3\text{ V}$, $f = 900\text{ MHz}$	14
Table 5-6	AC Characteristics, $V_{CE} = 3\text{ V}$, $f = 1.5\text{ GHz}$	15
Table 5-7	AC Characteristics, $V_{CE} = 3\text{ V}$, $f = 1.9\text{ GHz}$	15
Table 5-8	AC Characteristics, $V_{CE} = 3\text{ V}$, $f = 2.4\text{ GHz}$	16
Table 5-9	AC Characteristics, $V_{CE} = 3\text{ V}$, $f = 3.5\text{ GHz}$	16
Table 5-10	AC Characteristics, $V_{CE} = 3\text{ V}$, $f = 5.5\text{ GHz}$	17
Table 5-11	AC Characteristics, $V_{CE} = 3\text{ V}$, $f = 10\text{ GHz}$	17

1 Product Brief

The BFP720 is a very low noise wideband NPN bipolar RF transistor. The device is based on Infineon's reliable high volume silicon germanium carbon (SiGe:C) heterojunction bipolar technology. The collector design supports voltages up to $V_{CE0} = 4\text{ V}$ and currents up to $I_C = 25\text{ mA}$. The device is especially suited for mobile applications in which low power consumption is a key requirement. The typical transition frequency is approximately 45 GHz, hence the device offers high power gain at frequencies up to 12 GHz in amplifier applications. The device is housed in an easy to use plastic package with visible leads.

2 Features

- High performance general purpose wideband LNA transistor
- Operation voltage: 1.0 V to 4.0 V
- Transistor geometry optimized for low-current applications
- 26 dB maximum stable gain at 1.9 GHz and only 13 mA
- 15 dB maximum available gain at 10 GHz and only 13 mA
- 0.7 dB minimum noise figure at 5.5 GHz and 0.95 dB at 10 GHz
- High linearity $OP_{1dB} = 8.5$ dBm and $OIP_3 = 23$ dBm at 5.5 GHz and low current consumption of 13 mA
- Easy to use Pb-free (RoHS compliant) and halogen-free standard package with visible leads
- Qualification report according to AEC-Q101 available

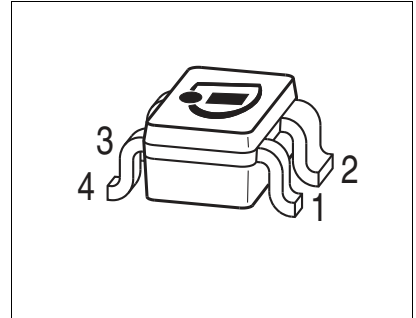

Applications

FM Radio, Mobile TV, RKE, AMR, Cellular, ZigBee, GPS, WiMAX, SDARs, Bluetooth, WiFi, Cordless phone, UMTS, WLAN, UWB, LNB

Attention: ESD (Electrostatic discharge) sensitive device, observe handling precautions

Product Name	Package	Pin Configuration				Marking
BFP720	SOT343	1 = B	2 = E	3 = C	4 = E	R9s

3 Maximum Ratings

Table 3-1 Maximum Ratings at $T_A = 25\text{ °C}$ (unless otherwise specified)

Parameter	Symbol	Values			Unit	Note / Test Condition
		Min.	Typ.	Max.		
Collector emitter voltage	V_{CEO}	– –	– –	4.0 3.5	V	Open base $T_A = 25\text{ °C}$ $T_A = -55\text{ °C}$
Collector emitter voltage	V_{CES}	–	–	13	V	E-B short circuited
Collector base voltage	V_{CBO}	–	–	13	V	Open emitter
Emitter base voltage	V_{EBO}	–	–	1.2	V	Open collector
Collector current	I_C	–	–	25	mA	
Base current	I_B	–	–	2	mA	
Total power dissipation ¹⁾	P_{tot}	–	–	100	mW	$T_S \leq 108\text{ °C}$
Junction temperature	T_J	–	–	150	°C	
Storage temperature	T_{Stg}	-55	–	150	°C	

1) T_S is the soldering point temperature. T_S is measured on the emitter lead at the soldering point to the pcb

Attention: Stresses above the max. values listed here may cause permanent damage to the device. Exposure to absolute maximum rating conditions for extended periods may affect device reliability. Maximum ratings are absolute ratings; exceeding only one of these values may cause irreversible damage to the integrated circuit.

4 Thermal Characteristics

Table 4-1 Thermal Resistance

Parameter	Symbol	Values			Unit	Note / Test Condition
		Min.	Typ.	Max.		
Junction - soldering point ¹⁾	R_{thJS}	–	420	–	K/W	–

1)For the definition of R_{thJS} please refer to Application Note AN077 (Thermal Resistance Calculation)

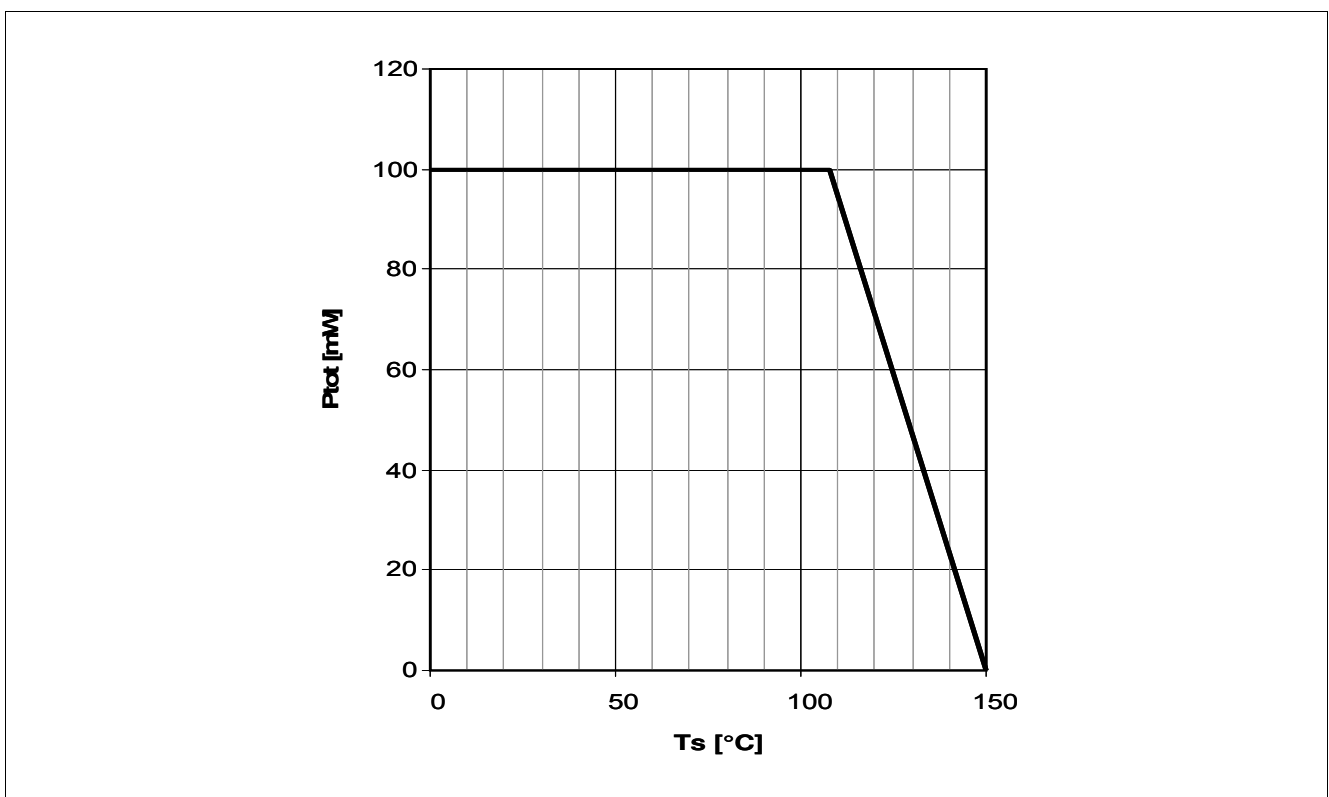

Figure 4-1 Total Power Dissipation $P_{tot} = f(T_s)$

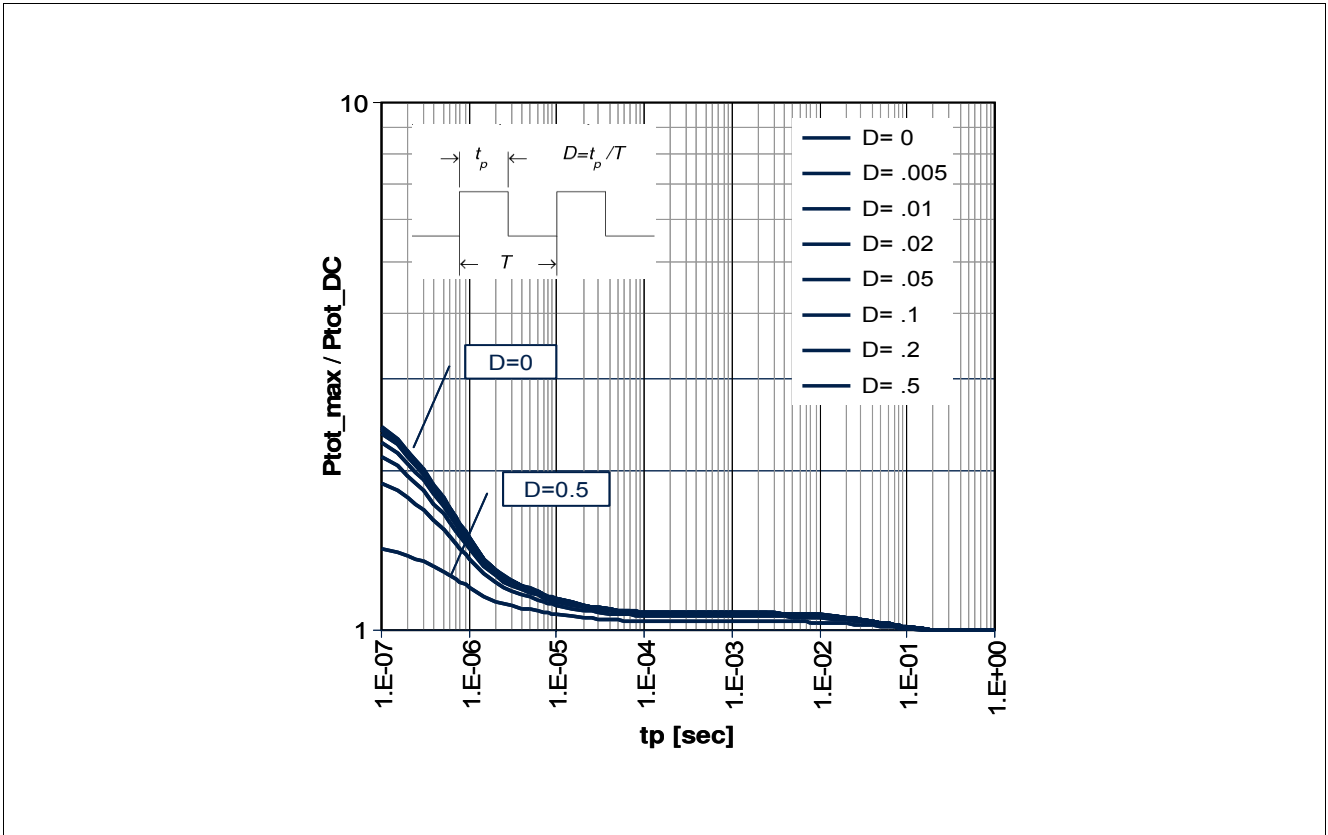

Figure 4-2 Permissible Pulse Load $P_{tot_max} / P_{tot_DC} = f(t_p)$

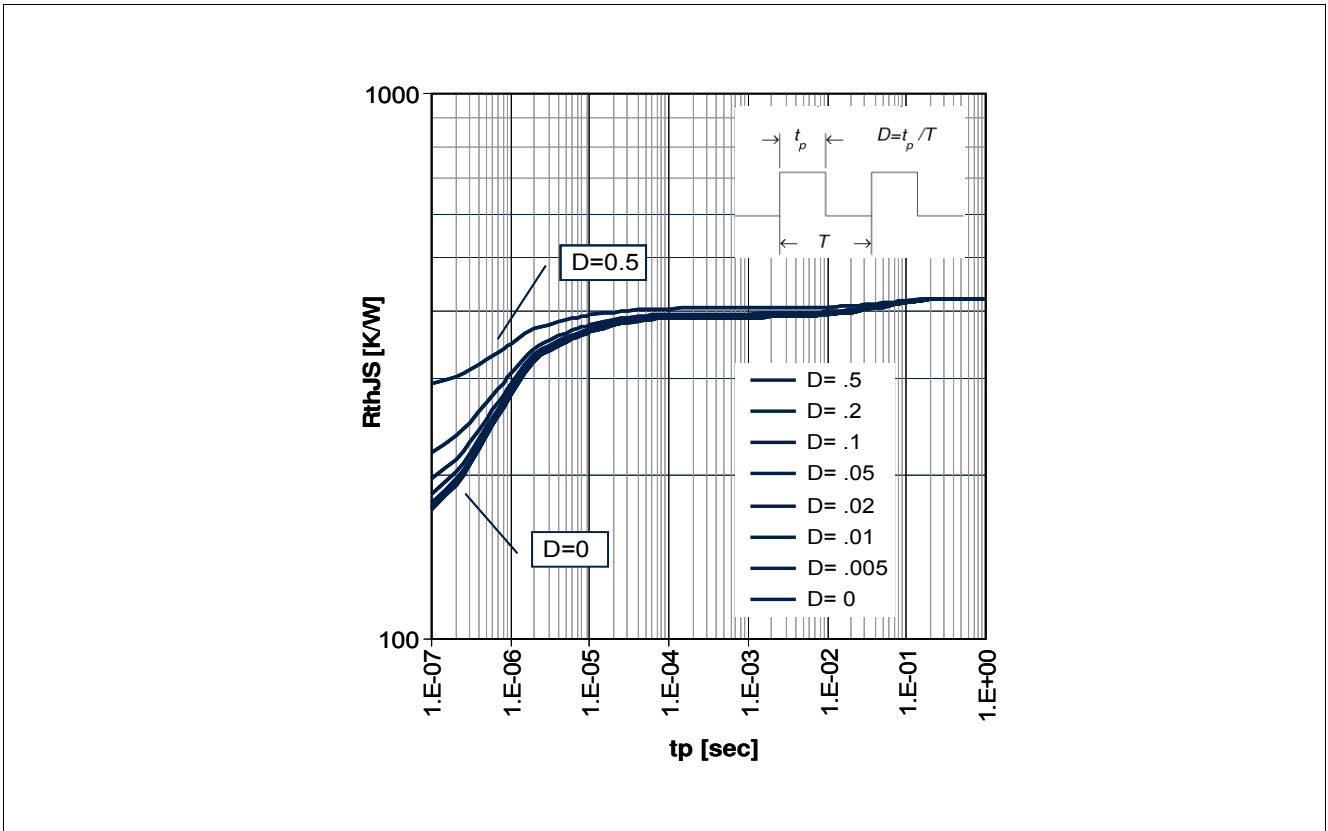

Figure 4-3 Permissible Pulse Load $R_{thJS} = f(t_p)$

5 Electrical Characteristics

5.1 DC Characteristics

Table 5-1 DC Characteristics at $T_A = 25\text{ °C}$

Parameter	Symbol	Values			Unit	Note / Test Condition
		Min.	Typ.	Max.		
Collector emitter breakdown voltage	$V_{(BR)CEO}$	4	4.7	–	V	$I_C = 1\text{ mA}, I_B = 0\text{ mA}$
Collector emitter cutoff current	I_{CES}	–	–	30	μA	$V_{CE} = 13\text{ V}, V_{BE} = 0\text{ V}$
Collector base cutoff current	I_{CBO}	–	–	100	nA	$V_{CB} = 5\text{ V}, I_E = 0\text{ mA}$
Emitter base cutoff current	I_{EBO}	–	–	2	μA	$V_{EB} = 0.5\text{ V}, I_C = 0\text{ mA}$
DC current gain	h_{FE}	160	250	400		$I_C = 13\text{ mA}, V_{CE} = 3\text{ V}$ pulse measured

5.2 General AC Characteristics

Table 5-2 AC Characteristics at $T_A = 25\text{ °C}$

Parameter	Symbol	Values			Unit	Note / Test Condition
		Min.	Typ.	Max.		
Transition frequency	f_T	–	45	–	GHz	$I_C = 13\text{ mA}, V_{CE} = 3\text{ V}$ $f = 1\text{ GHz}$
Collector base capacitance	C_{CB}	–	0.06	–	pF	$V_{CB} = 3\text{ V}, V_{BE} = 0\text{ V}$ $f = 1\text{ MHz}$ emitter grounded
Collector emitter capacitance	C_{CE}	–	0.35	–	pF	$V_{CE} = 3\text{ V}, V_{BE} = 0\text{ V}$ $f = 1\text{ MHz}$ base grounded
Emitter base capacitance	C_{EB}	–	0.35	–	pF	$V_{EB} = 0.5\text{ V}, V_{CB} = 0\text{ V}$ $f = 1\text{ MHz}$ collector grounded

5.3 Frequency Dependent AC Characteristics

Measurement setup is a test fixture with Bias T's in a 50 Ω system, $T_A = 25\text{ °C}$

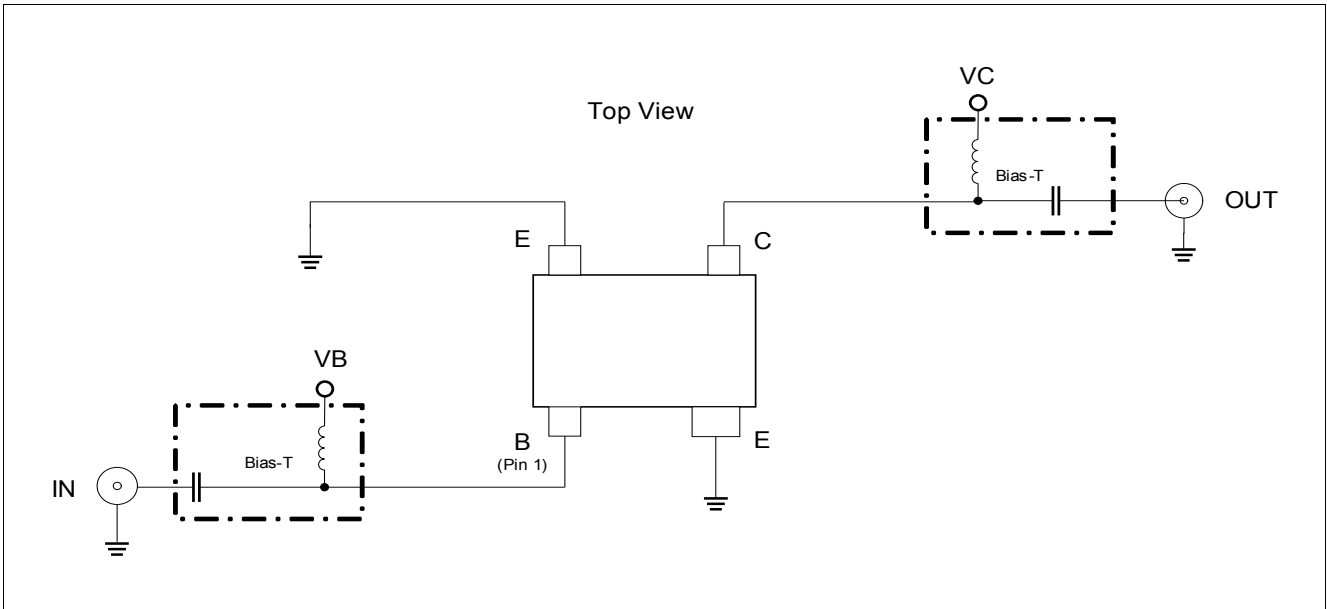

Figure 5-1 BFP720 Testing Circuit

Table 5-3 AC Characteristics, $V_{CE} = 3\text{ V}$, $f = 150\text{ MHz}$

Parameter	Symbol	Values			Unit	Note / Test Condition
		Min.	Typ.	Max.		
Maximum Power Gain					dB	
Low noise operation point	G_{ms}	–	34	–		$I_C = 5\text{ mA}$
High linearity operation point	G_{ms}	–	37.5	–		$I_C = 13\text{ mA}$
Transducer Gain					dB	$Z_S = Z_L = 50\text{ }\Omega$
Low noise operation point	S_{21}	–	23	–		$I_C = 5\text{ mA}$
High linearity operation point	S_{21}	–	29.5	–		$I_C = 13\text{ mA}$
Minimum Noise Figure					dB	$Z_S = Z_{opt}$
Minimum noise figure	NF_{min}	–	0.4	–		$I_C = 5\text{ mA}$
Associated gain	G_{ass}	–	28.5	–		$I_C = 5\text{ mA}$
Linearity					dBm	$Z_S = Z_L = 50\text{ }\Omega$
1 dB gain compression point	OP_{1dB}	–	6	–		$I_C = 13\text{ mA}$
3rd order intercept point	OIP_3	–	22	–		$I_C = 13\text{ mA}$

Table 5-4 AC Characteristics, $V_{CE} = 3\text{ V}$, $f = 450\text{ MHz}$

Parameter	Symbol	Values			Unit	Note / Test Condition
		Min.	Typ.	Max.		
Maximum Power Gain						
Low noise operation point	G_{ms}	–	29	–	dB	$I_C = 5\text{ mA}$
High linearity operation point	G_{ms}	–	32.5	–		$I_C = 13\text{ mA}$
Transducer Gain						
Low noise operation point	S_{21}	–	23	–	dB	$Z_S = Z_L = 50\ \Omega$ $I_C = 5\text{ mA}$
High linearity operation point	S_{21}	–	28.5	–		$I_C = 13\text{ mA}$
Minimum Noise Figure						
Minimum noise figure	NF_{min}	–	0.4	–	dB	$Z_S = Z_{opt}$ $I_C = 5\text{ mA}$
Associated gain	G_{ass}	–	28	–		$I_C = 5\text{ mA}$
Linearity						
1 dB gain compression point	OP_{1dB}	–	5.5	–	dBm	$Z_S = Z_L = 50\ \Omega$ $I_C = 13\text{ mA}$
3 rd order intercept point	OIP_3	–	21.5	–		$I_C = 13\text{ mA}$

Table 5-5 AC Characteristics, $V_{CE} = 3\text{ V}$, $f = 900\text{ MHz}$

Parameter	Symbol	Values			Unit	Note / Test Condition
		Min.	Typ.	Max.		
Maximum Power Gain						
Low noise operation point	G_{ms}	–	26.5	–	dB	$I_C = 5\text{ mA}$
High linearity operation point	G_{ms}	–	29.5	–		$I_C = 13\text{ mA}$
Transducer Gain						
Low noise operation point	S_{21}	–	22.5	–	dB	$Z_S = Z_L = 50\ \Omega$ $I_C = 5\text{ mA}$
High linearity operation point	S_{21}	–	27.5	–		$I_C = 13\text{ mA}$
Minimum Noise Figure						
Minimum noise figure	NF_{min}	–	0.4	–	dB	$Z_S = Z_{opt}$ $I_C = 5\text{ mA}$
Associated gain	G_{ass}	–	26	–		$I_C = 5\text{ mA}$
Linearity						
1 dB gain compression point	OP_{1dB}	–	5.5	–	dBm	$Z_S = Z_L = 50\ \Omega$ $I_C = 13\text{ mA}$
3 rd order intercept point	OIP_3	–	21	–		$I_C = 13\text{ mA}$

Table 5-6 AC Characteristics, $V_{CE} = 3\text{ V}$, $f = 1.5\text{ GHz}$

Parameter	Symbol	Values			Unit	Note / Test Condition
		Min.	Typ.	Max.		
Maximum Power Gain						
Low noise operation point	G_{ms}	–	24	–	dB	$I_C = 5\text{ mA}$
High linearity operation point	G_{ms}	–	27.5	–		$I_C = 13\text{ mA}$
Transducer Gain						
Low noise operation point	S_{21}	–	22	–	dB	$Z_S = Z_L = 50\ \Omega$ $I_C = 5\text{ mA}$
High linearity operation point	S_{21}	–	25.5	–		$I_C = 13\text{ mA}$
Minimum Noise Figure						
Minimum noise figure	NF_{min}	–	0.45	–	dB	$Z_S = Z_{opt}$ $I_C = 5\text{ mA}$
Associated gain	G_{ass}	–	24	–		$I_C = 5\text{ mA}$
Linearity						
1 dB gain compression point	OP_{1dB}	–	6	–	dBm	$Z_S = Z_L = 50\ \Omega$ $I_C = 13\text{ mA}$
3 rd order intercept point	OIP_3	–	21.5	–		$I_C = 13\text{ mA}$

 Table 5-7 AC Characteristics, $V_{CE} = 3\text{ V}$, $f = 1.9\text{ GHz}$

Parameter	Symbol	Values			Unit	Note / Test Condition
		Min.	Typ.	Max.		
Maximum Power Gain						
Low noise operation point	G_{ms}	–	23	–	dB	$I_C = 5\text{ mA}$
High linearity operation point	G_{ms}	–	26	–		$I_C = 13\text{ mA}$
Transducer Gain						
Low noise operation point	S_{21}	–	21.5	–	dB	$Z_S = Z_L = 50\ \Omega$ $I_C = 5\text{ mA}$
High linearity operation point	S_{21}	–	24.5	–		$I_C = 13\text{ mA}$
Minimum Noise Figure						
Minimum noise figure	NF_{min}	–	0.45	–	dB	$Z_S = Z_{opt}$ $I_C = 5\text{ mA}$
Associated gain	G_{ass}	–	23	–		$I_C = 5\text{ mA}$
Linearity						
1 dB gain compression point	OP_{1dB}	–	7	–	dBm	$Z_S = Z_L = 50\ \Omega$ $I_C = 13\text{ mA}$
3 rd order intercept point	OIP_3	–	22	–		$I_C = 13\text{ mA}$

Table 5-8 AC Characteristics, $V_{CE} = 3\text{ V}$, $f = 2.4\text{ GHz}$

Parameter	Symbol	Values			Unit	Note / Test Condition
		Min.	Typ.	Max.		
Maximum Power Gain						
Low noise operation point	G_{ms}	–	22	–	dB	$I_C = 5\text{ mA}$
High linearity operation point	G_{ms}	–	25	–		$I_C = 13\text{ mA}$
Transducer Gain						
Low noise operation point	S_{21}	–	20.5	–	dB	$Z_S = Z_L = 50\ \Omega$ $I_C = 5\text{ mA}$
High linearity operation point	S_{21}	–	23	–		$I_C = 13\text{ mA}$
Minimum Noise Figure						
Minimum noise figure	NF_{min}	–	0.5	–	dB	$Z_S = Z_{opt}$ $I_C = 5\text{ mA}$
Associated gain	G_{ass}	–	21.5	–		$I_C = 5\text{ mA}$
Linearity						
1 dB gain compression point	OP_{1dB}	–	6	–	dBm	$Z_S = Z_L = 50\ \Omega$ $I_C = 13\text{ mA}$
3 rd order intercept point	OIP_3	–	22	–		$I_C = 13\text{ mA}$

 Table 5-9 AC Characteristics, $V_{CE} = 3\text{ V}$, $f = 3.5\text{ GHz}$

Parameter	Symbol	Values			Unit	Note / Test Condition
		Min.	Typ.	Max.		
Maximum Power Gain						
Low noise operation point	G_{ms}	–	20.5	–	dB	$I_C = 5\text{ mA}$
High linearity operation point	G_{ms}	–	23.5	–		$I_C = 13\text{ mA}$
Transducer Gain						
Low noise operation point	S_{21}	–	18.5	–	dB	$Z_S = Z_L = 50\ \Omega$ $I_C = 5\text{ mA}$
High linearity operation point	S_{21}	–	20	–		$I_C = 13\text{ mA}$
Minimum Noise Figure						
Minimum noise figure	NF_{min}	–	0.55	–	dB	$Z_S = Z_{opt}$ $I_C = 5\text{ mA}$
Associated gain	G_{ass}	–	19	–		$I_C = 5\text{ mA}$
Linearity						
1 dB gain compression point	OP_{1dB}	–	7.5	–	dBm	$Z_S = Z_L = 50\ \Omega$ $I_C = 13\text{ mA}$
3 rd order intercept point	OIP_3	–	22.5	–		$I_C = 13\text{ mA}$

Table 5-10 AC Characteristics, $V_{CE} = 3\text{ V}$, $f = 5.5\text{ GHz}$

Parameter	Symbol	Values			Unit	Note / Test Condition
		Min.	Typ.	Max.		
Maximum Power Gain	G_{ms}				dB	$I_C = 5\text{ mA}$
Low noise operation point	G_{ma}	–	19	–		
High linearity operation point		–	19.5	–		$I_C = 13\text{ mA}$
Transducer Gain					dB	$Z_S = Z_L = 50\ \Omega$
Low noise operation point	S_{21}	–	15	–		
High linearity operation point	S_{21}	–	16	–		$I_C = 13\text{ mA}$
Minimum Noise Figure					dB	$Z_S = Z_{opt}$
Minimum noise figure	NF_{min}	–	0.7	–		
Associated gain	G_{ass}	–	15	–		$I_C = 5\text{ mA}$
Linearity					dBm	$Z_S = Z_L = 50\ \Omega$
1 dB gain compression point	OP_{1dB}	–	8.5	–		
3 rd order intercept point	OIP_3	–	23	–		$I_C = 13\text{ mA}$

 Table 5-11 AC Characteristics, $V_{CE} = 3\text{ V}$, $f = 10\text{ GHz}$

Parameter	Symbol	Values			Unit	Note / Test Condition
		Min.	Typ.	Max.		
Maximum Power Gain					dB	$I_C = 5\text{ mA}$
Low noise operation point	G_{ma}	–	13.5	–		
High linearity operation point	G_{ma}	–	15	–		$I_C = 13\text{ mA}$
Transducer Gain					dB	$Z_S = Z_L = 50\ \Omega$
Low noise operation point	S_{21}	–	9	–		
High linearity operation point	S_{21}	–	10	–		$I_C = 13\text{ mA}$
Minimum Noise Figure					dB	$Z_S = Z_{opt}$
Minimum noise figure	NF_{min}	–	0.95	–		
Associated gain	G_{ass}	–	10.5	–		$I_C = 5\text{ mA}$
Linearity					dBm	$Z_S = Z_L = 50\ \Omega$
1 dB gain compression point	OP_{1dB}	–	8	–		
3 rd order intercept point	OIP_3	–	19.5	–		$I_C = 13\text{ mA}$

Notes

- $G_{ms} = |S_{21} / S_{12}|$ for $k < 1$; $G_{ma} = |S_{21} / S_{12}|(k - (k^2 - 1)^{1/2})$ for $k > 1$
- In order to get the NF_{min} values stated in this chapter the test fixture losses have been subtracted from all measured results

5.4 Characteristic Curves

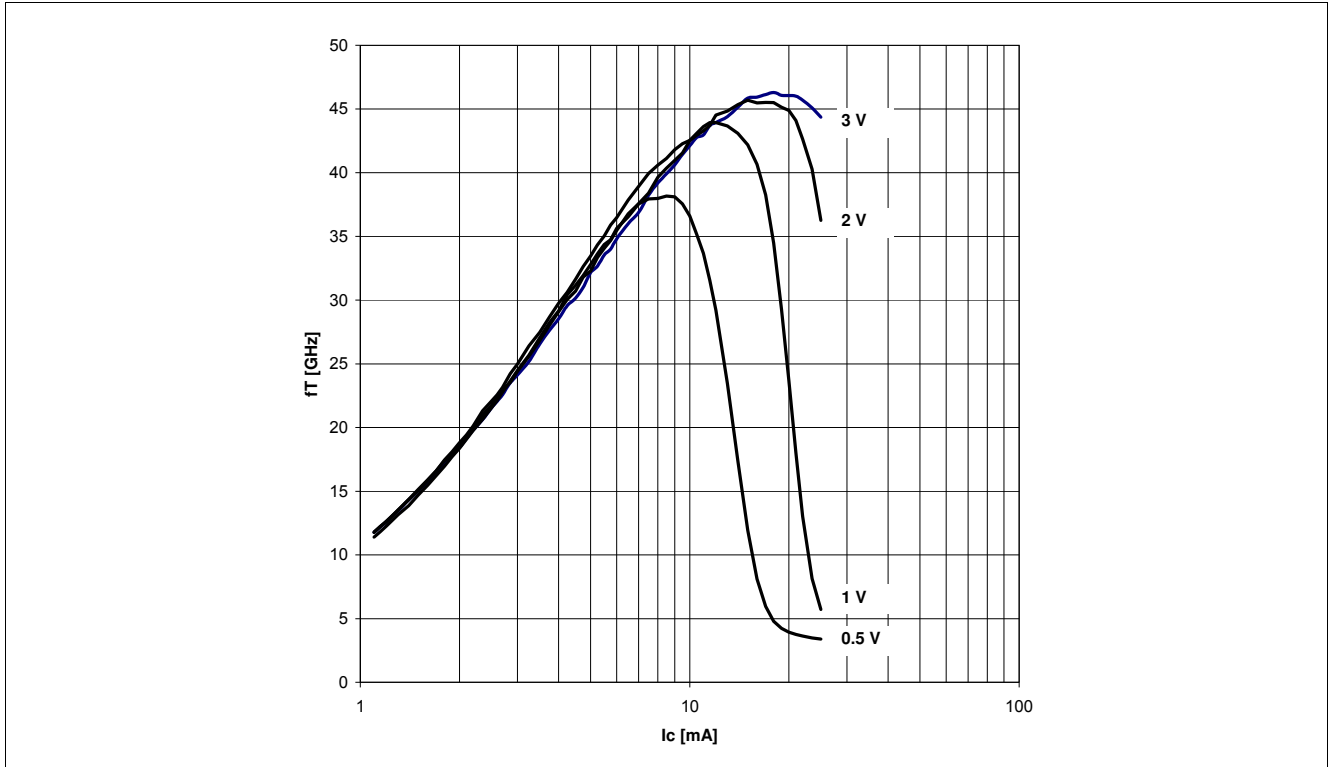

Figure 5-2 Transition Frequency $f_T = f(I_C, V_{CE})$, $f = 1 \text{ GHz}$, $V_{CE} = \text{Parameter in V}$

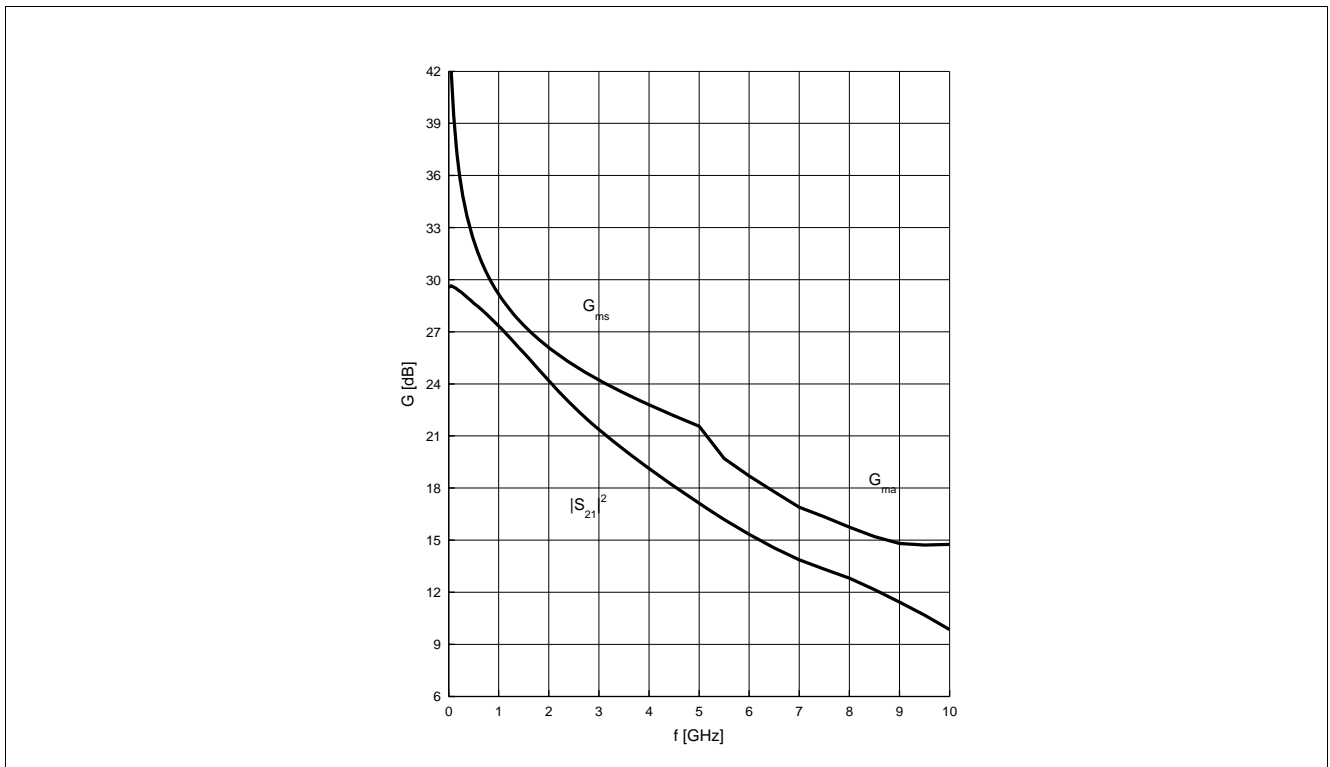

Figure 5-3 Power Gain G_{ma} , G_{ms} , $|S_{21}|^2 = f(f)$, $V_{CE} = 3 \text{ V}$, $I_C = 13 \text{ mA}$

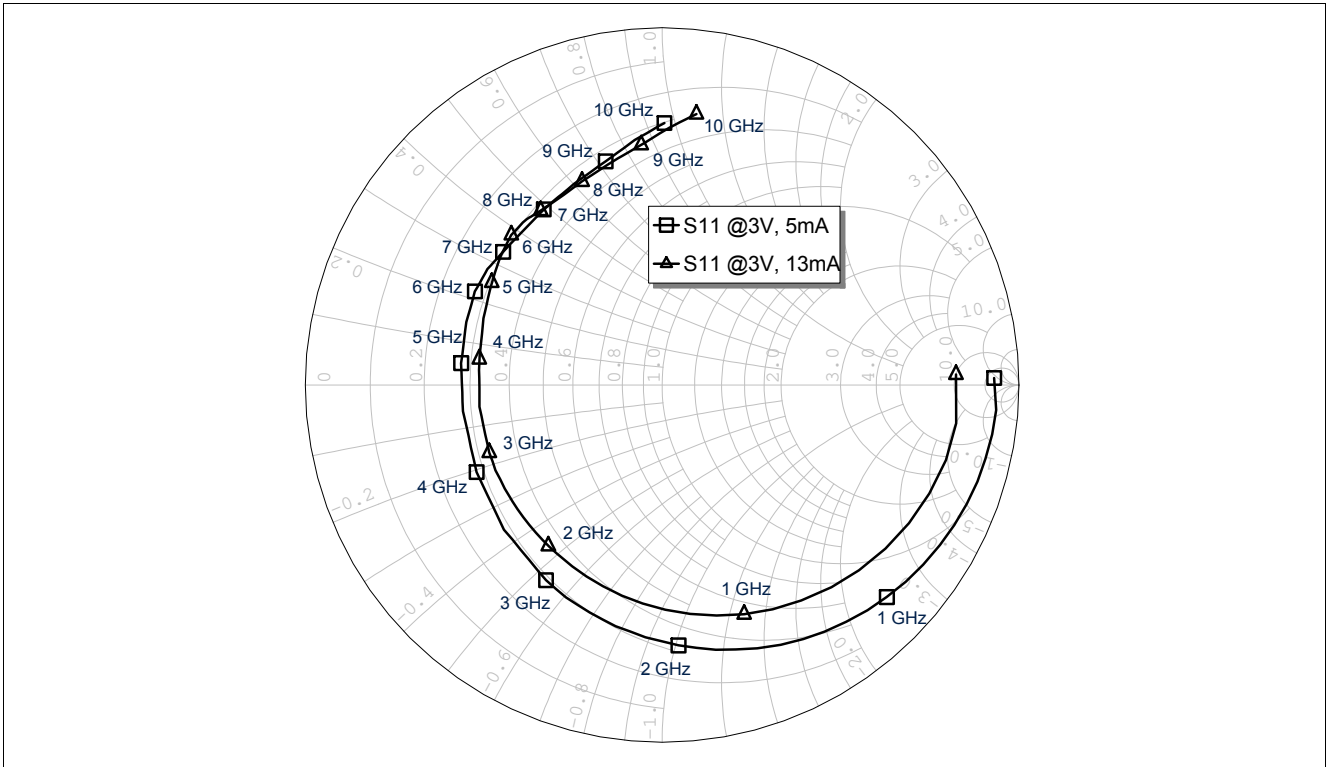

Figure 5-4 Input Matching $S_{11} = f(f)$, $V_{CE} = 3\text{ V}$, $I_C = 5\text{ mA} / 13\text{ mA}$

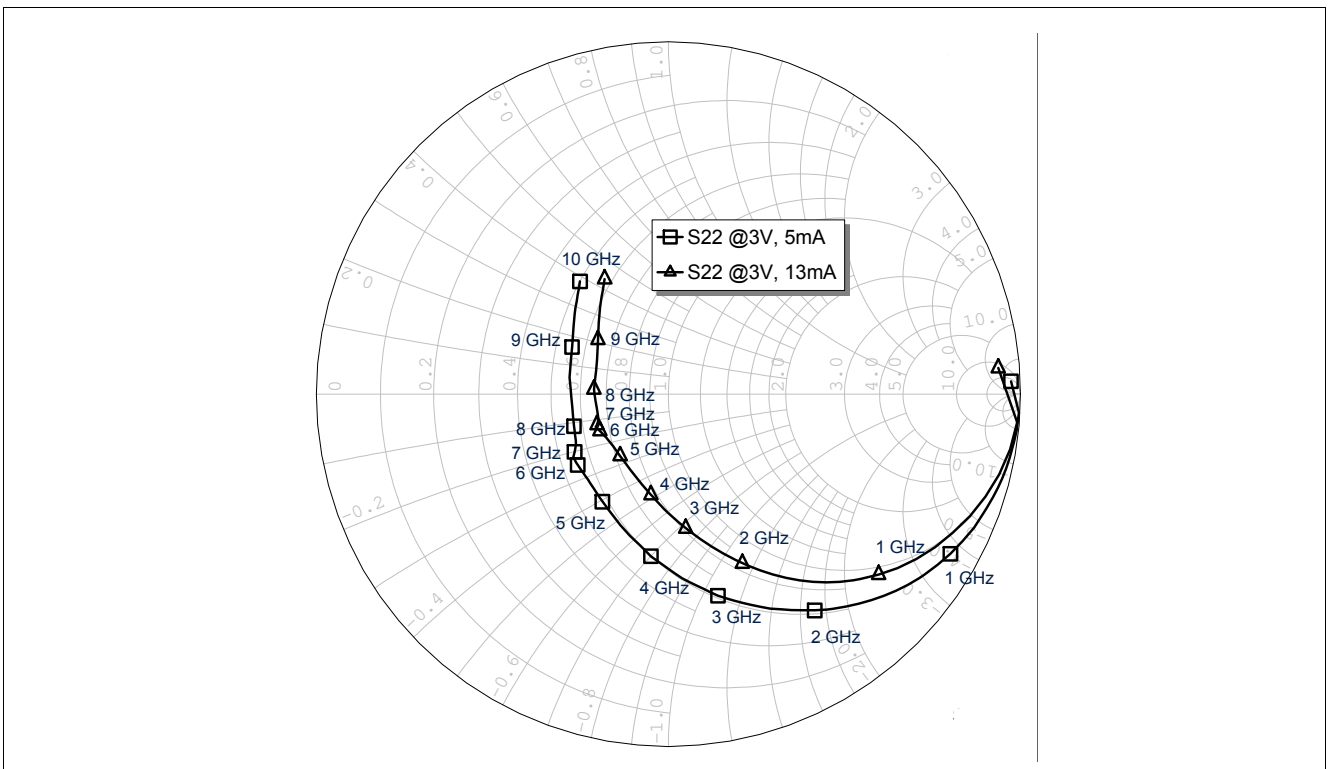

Figure 5-5 Output Matching $S_{22} = f(f)$, $V_{CE} = 3\text{ V}$, $I_C = 5\text{ mA} / 13\text{ mA}$

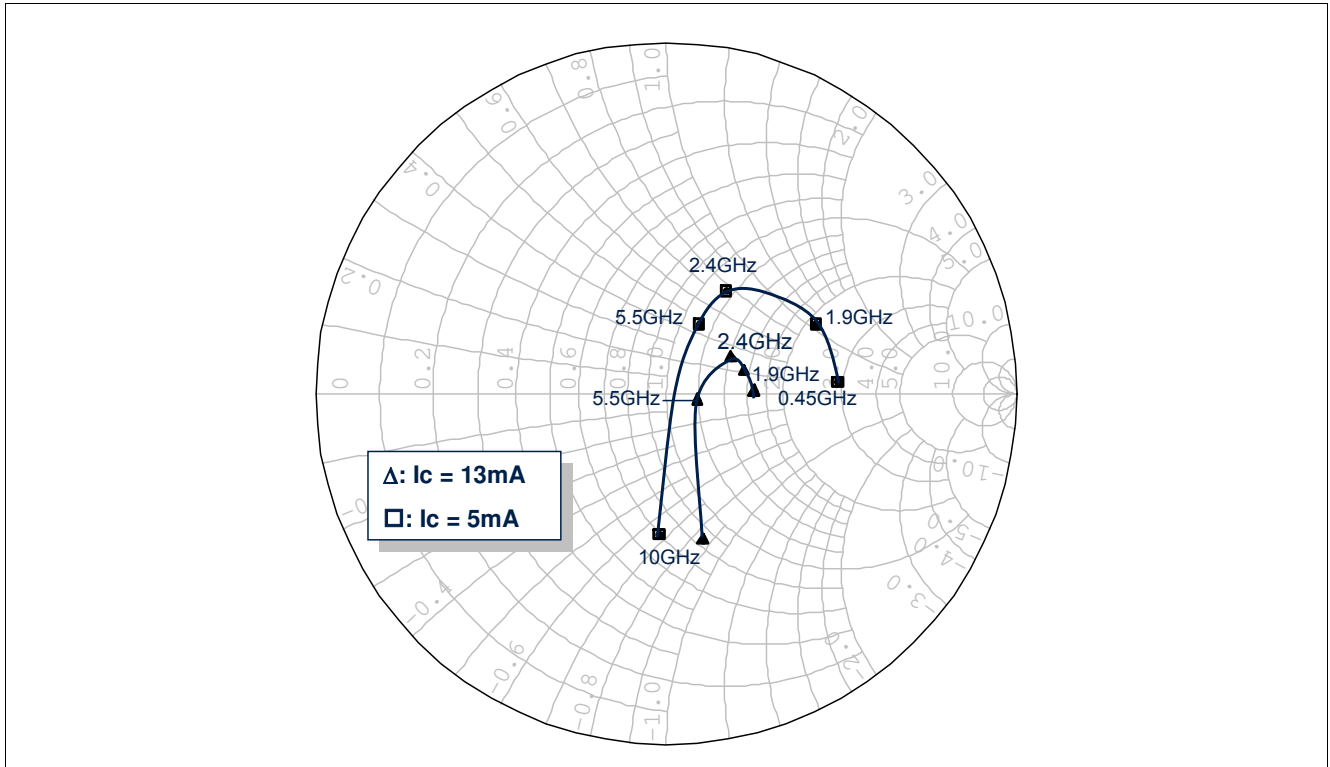

Figure 5-6 Source Impedance Z_{opt} for $NF_{min} = f(f)$, $V_{CE} = 3V$, $I_C = 5mA / 13mA$

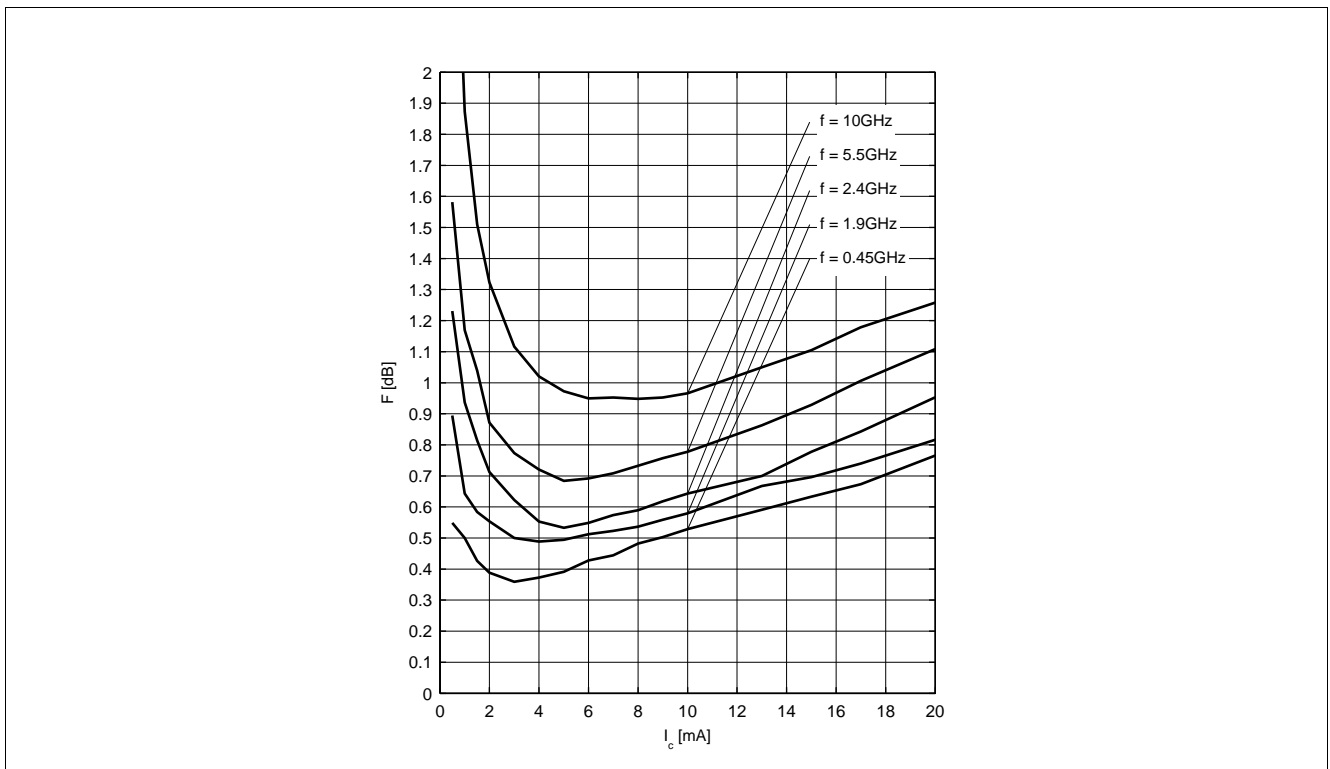

Figure 5-7 Noise Figure $NF_{min} = f(I_C)$, $V_{CE} = 3V$, $Z_S = Z_{opt}$

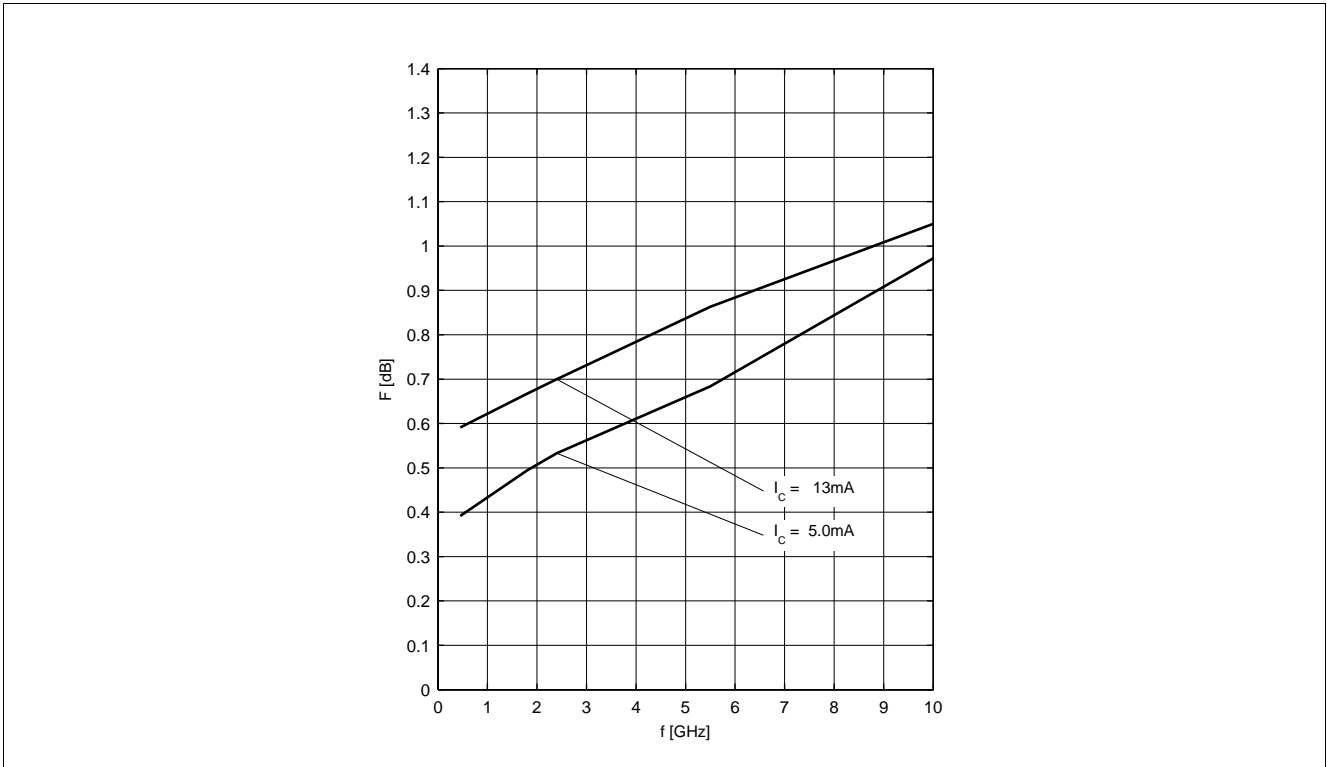

Figure 5-8 Noise Figure $NF_{min} = f(f)$, $V_{CE} = 3\text{ V}$, $Z_S = Z_{opt}$

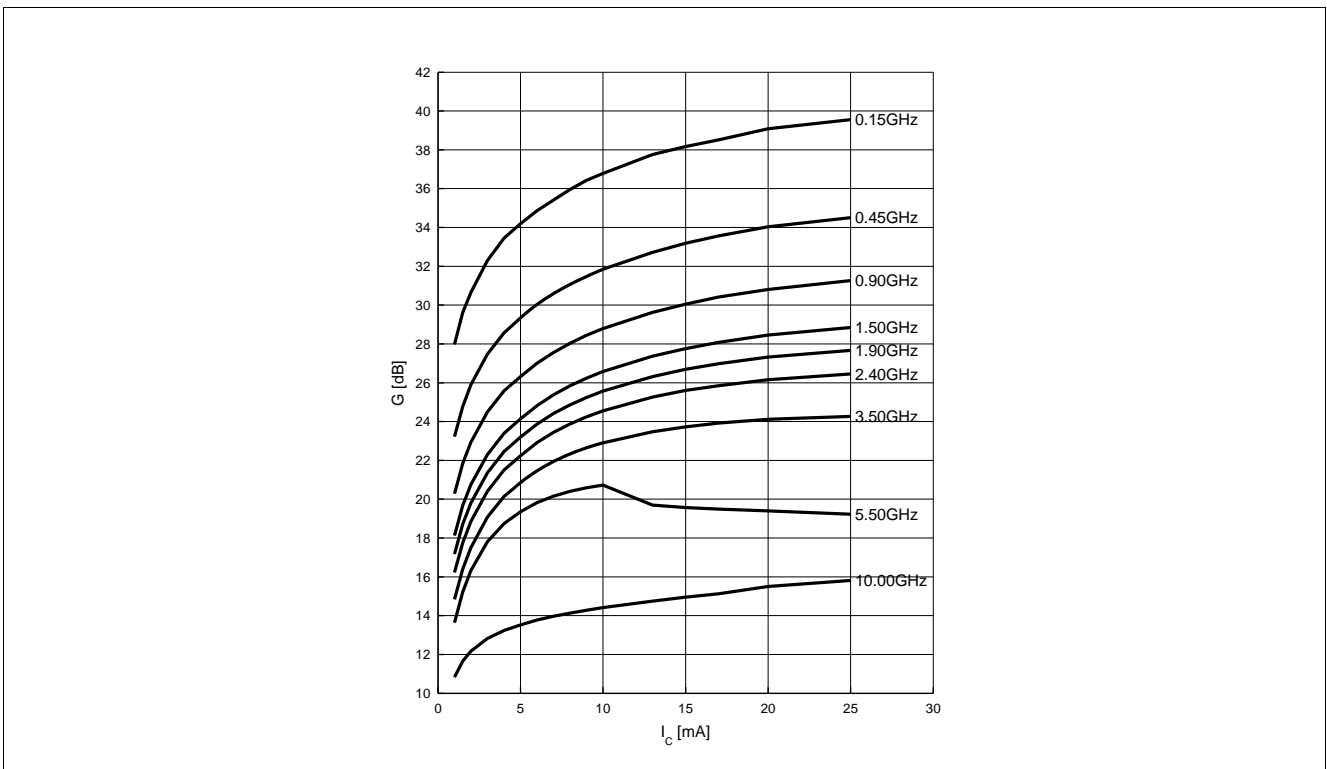

Figure 5-9 Power Gain $G_{ma}, G_{ms} = f(I_C)$, $V_{CE} = 3\text{ V}$, $f = \text{Parameter in GHz}$

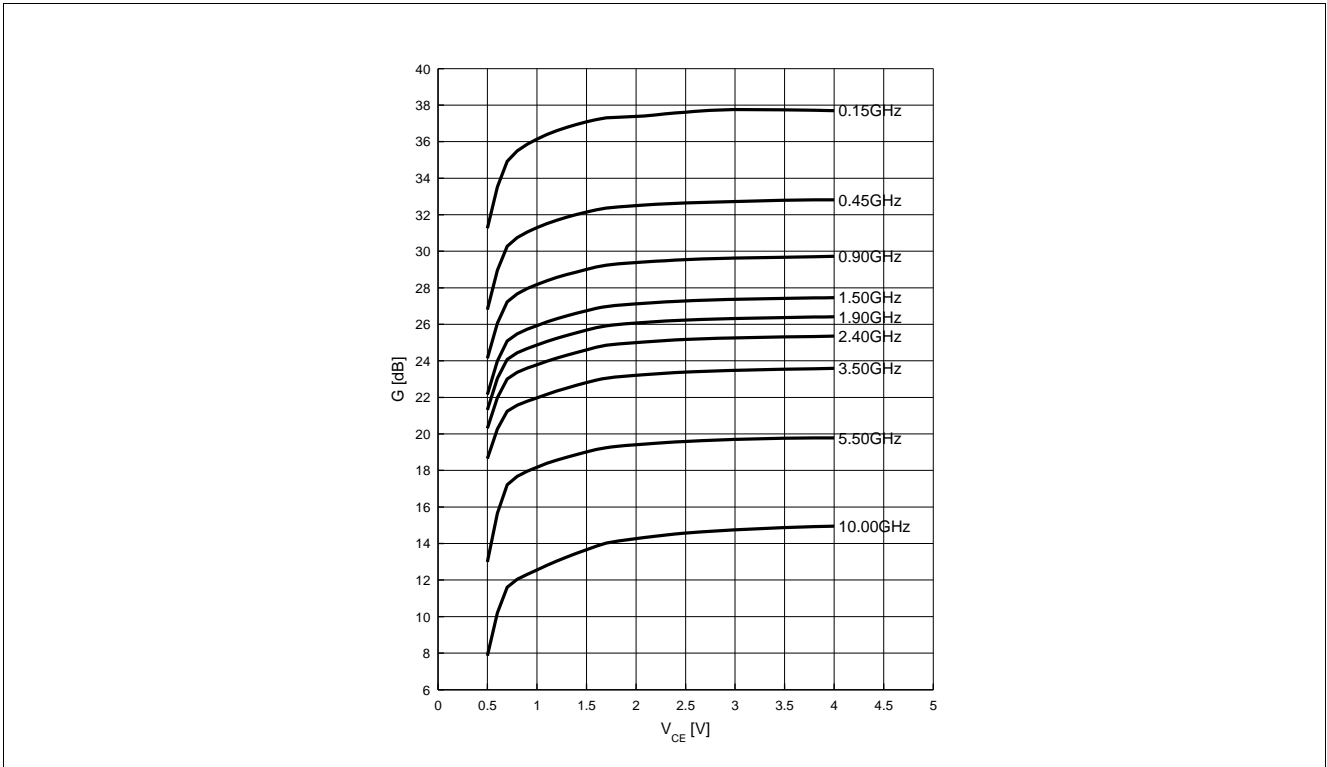

Figure 5-10 Power Gain G_{ms} , $G_{ms} = f(V_{CE})$, $I_C = 13 \text{ mA}$, $f = \text{Parameter in GHz}$

Note: The curves shown in this chapter have been generated using typical devices but shall not be considered as a guarantee that all devices have identical characteristic curves

6 Simulation Data

For the SPICE Gummel Poon (GP) model as well as for the S-parameters (including noise parameters) please refer to our internet website: www.infineon.com/rf.models. Please consult our website and download the latest versions before actually starting your design.

You find the BFP720 SPICE GP model in the internet in MWO- and ADS-format, which you can import into these circuit simulation tools very quickly and conveniently. The model already contains the package parasitic and is ready to use for DC- and high frequency simulations. The terminals of the model circuit correspond to the pin configuration of the device.

The model parameters have been extracted and verified up to 12 GHz using typical devices. The BFP720 SPICE GP model reflects the typical DC- and RF-performance within the limitations which are given by the SPICE GP model itself.

7 Package Information SOT343

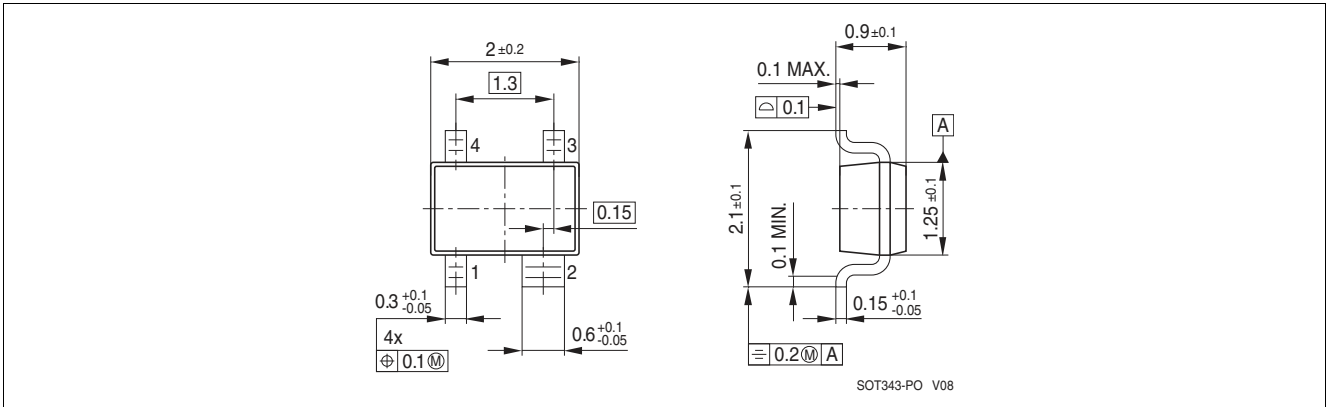

Figure 7-1 Package Outline

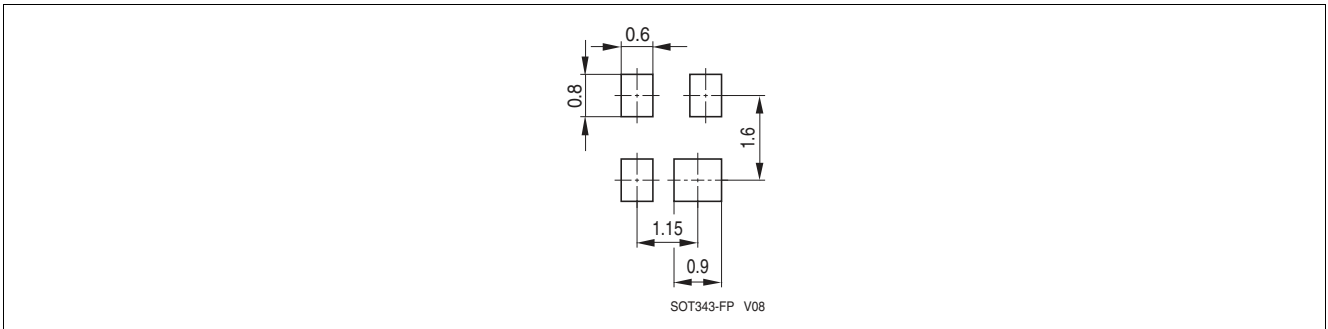

Figure 7-2 Package Footprint

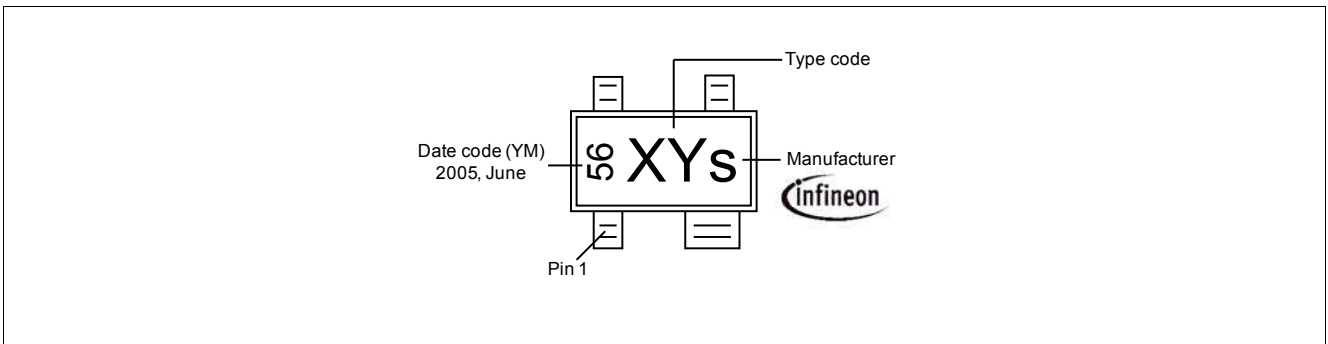

Figure 7-3 Marking Description (Marking BFP720: R9s)

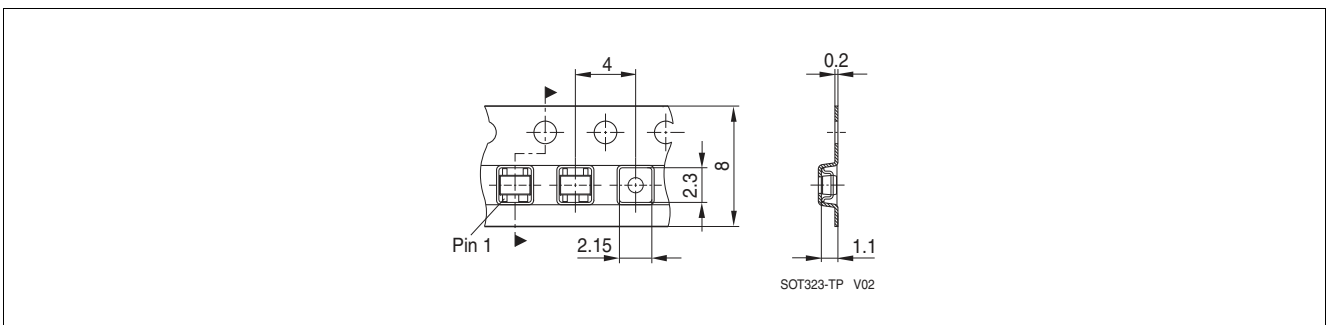

Figure 7-4 Tape Dimensions

www.infineon.com

Published by Infineon Technologies AG