

P.C.B. HOLE DRILLINGS

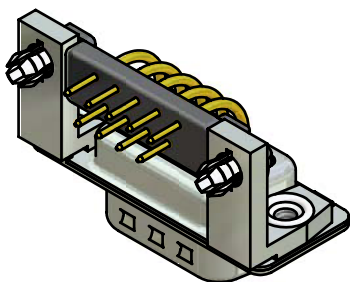
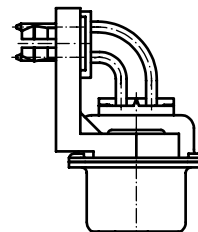
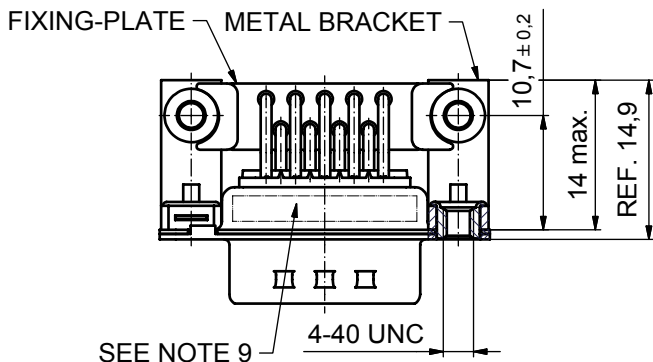
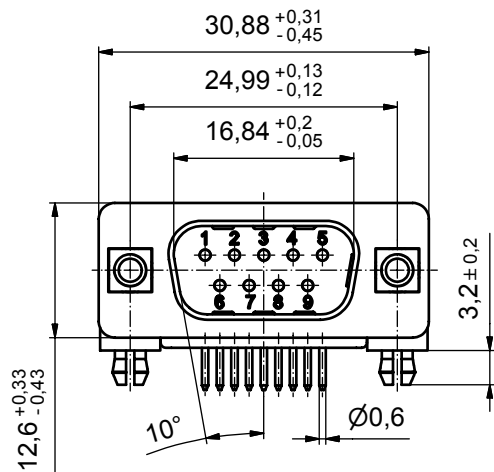
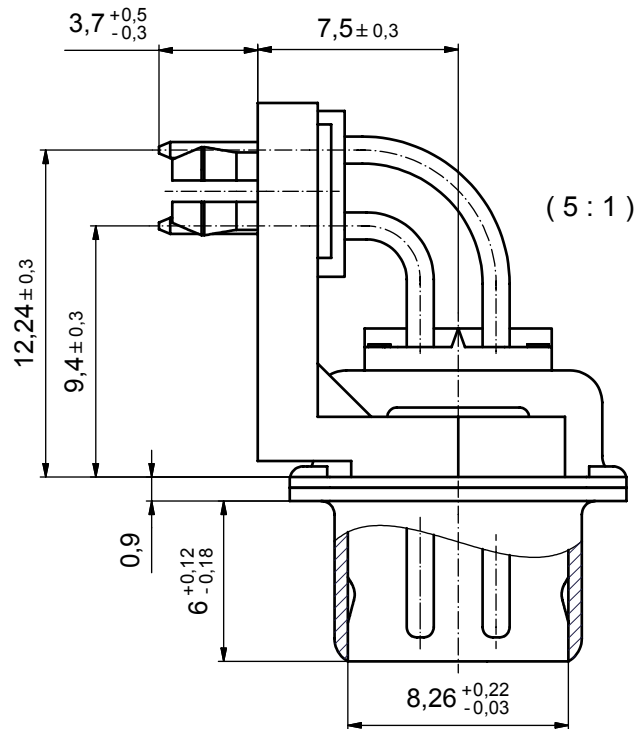

NOTES:

1. METALSHELLS: STEEL; min. 315µm TIN OVER 40-80µm NICKEL
2. INSULATORS: PBT GF UL 94 V-0, BLACK
3. CONTACTS: COPPER ALLOY
PLATING: 8µm HARD GOLD OVER min. 50µm NICKEL
4. METAL BRACKET: ZINC DIE CAST; 300µm COPPER/40-120µm NICKEL/120-200µm TIN
5. THREADED INSERT: COPPER ALLOY; min. 200µm TIN OVER 80µm NICKEL
6. PCB-SNAP: COPPER ALLOY; min. 200µm TIN OVER 80µm NICKEL
PCB-HOLE: $\varnothing 3.1 \pm 0.1$; PCB THICKNESS 1.6mm
7. FIXING-PLATE: PBT GF UL 94 V-0, BLACK
8. MAXIMUM TORQUE VALUE FOR THREAD: 6 in.LB
9. CONNECTOR IS PART MARKED: 163A16359X CONEC ABC

Directive 2002/95/EC
RoHS
Compliant

APPROVAL # FREIGABE # DEBLOCAGE # AUTORIZACION # APPROVAL	
CUSTOMER APPROVAL DATE:	
NAME:	TITLE:
COMPANY NAME:	
APPROVAL # FREIGABE # DEBLOCAGE # AUTORIZACION # APPROVAL	

tolerance				dim. in mm	scale: 2:1 (5:1)			
dim. in mm					material: SEE NOTES			
CONEC [®]				title:		D-SUB MALE 90° 9pos. SOLDER PIN ANGLED 0.370inch thread insert, metal bracket, fixing-plate, snap		
				drawn	13.03.07		Lehmenkühler	
				appd.	13.03.07		Mickenbecker	
				norm	DIN 41652		dwg no:	Inventor
a	Origin			16K2A1804		sh: 1		
rev.	description	date	name	part no: 163A16359X				

THIS DRAWING MAY NOT BE COPIED OR REPRODUCED IN ANY WAY, AND MAY NOT BE PASSED ON TO A THIRD PARTY WITHOUT WRITTEN PERMISSION. OWNERSHIP AND COPYRIGHT OF CONEC GmbH DO NOT ALTER CAD DRAWING BY HAND