

DO NOT SCALE FROM THIS PRINT

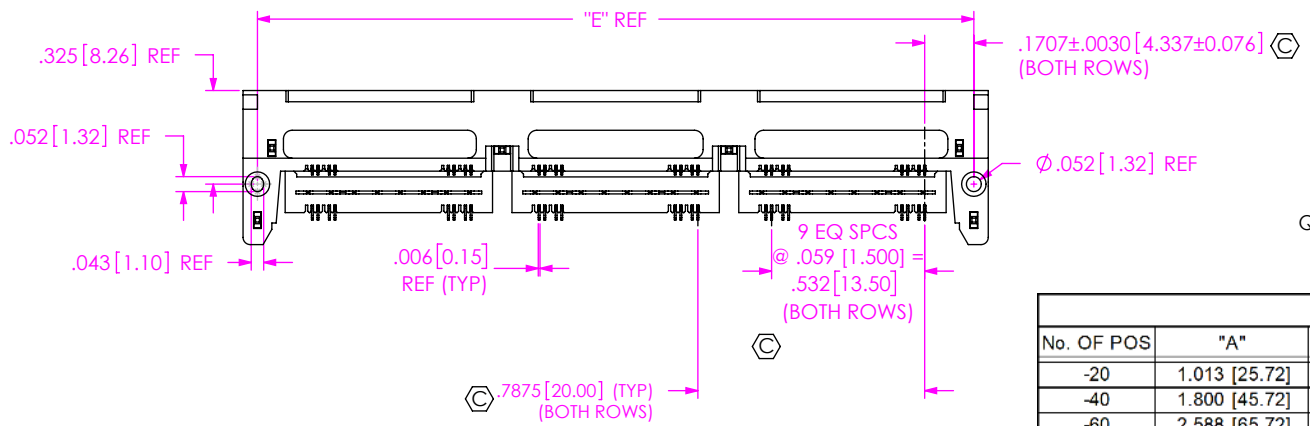
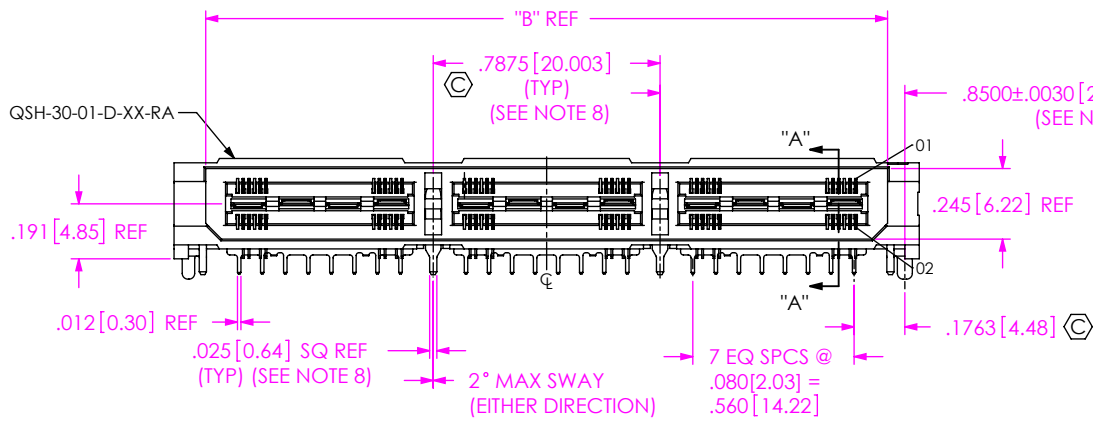
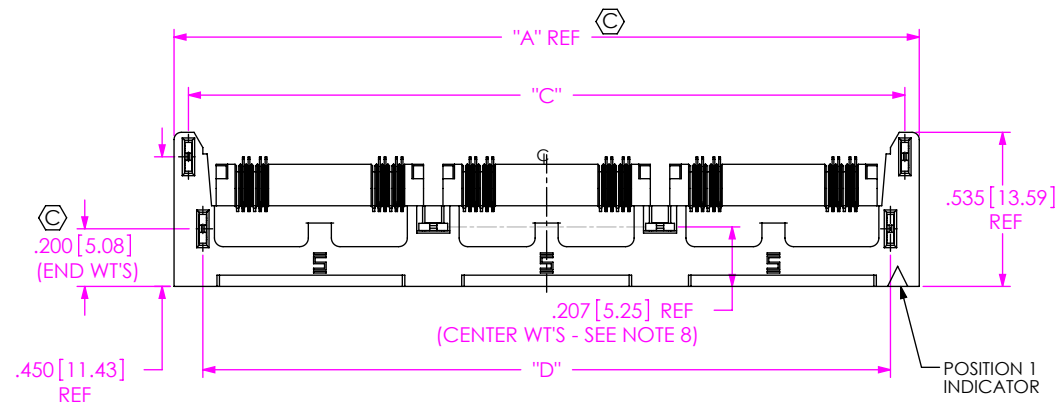

**QSH-XXX-XX-X-D-DP-RA-XXX**

No. OF POSITIONS  
-020, -040, -060 (PER ROW)

LEAD STYLE  
-01: (SEE NOTE 6)

PLATING SPECIFICATION  
SEE SHEET 2, TABLE 4

ROW SPECIFICATION  
-D: DOUBLE (USE QSH-30-01-D-XX-RA)

OPTION  
-GP: GUIDE POST (SEE FIG 3, SHT 6) (FOR MATING WITH QTH-...-D-DP-RA-...PGP)  
\* -LS1: LOCKING SCREW (SEE FIG 2, SHT 5) (FOR MATING WITH QTH-...-RA-...LS1)  
-K: PAD (SEE FIG 4, SHT 6) (USE K-DOT-256-375-005)  
-RA: RIGHT ANGLE  
-DP: DIFFERENTIAL PAIRS

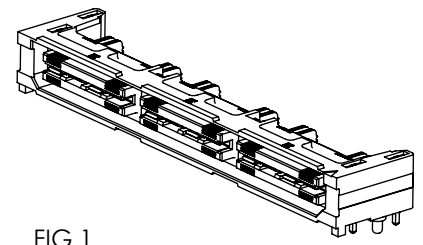
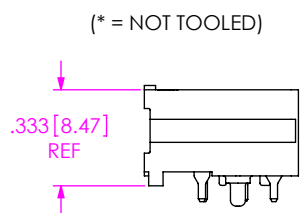

FIG 1  
QSH-060-01-X-D-DP-RA SHOWN

**TABLE 1**

No. OF POS	"A"	"B"	"C"	"D"	"E"
-20	1.013 [25.72]	.793 [20.13]	.913 [23.18]	.813 [20.64]	.913 [23.18]
-40	1.800 [45.72]	1.580 [40.13]	1.700 [43.18]	1.600 [40.64]	1.700 [43.18]
-60	2.588 [65.72]	2.368 [60.13]	2.488 [63.18]	2.388 [60.64]	2.488 [63.18]

- NOTES:
- ⊗ REPRESENTS A CRITICAL DIMENSION.
  - MAXIMUM BURR ALLOWANCE: .0010
  - MINIMUM PUSHOUT FORCE: 6 OZ
  - IF NEEDED, -L PLATING CAN BE SUBSTITUTED FOR -F PLATING.
  - IM-1G18-01-2-XXX RETENTION TO BE 1.0 LB MINIMUM PRIOR TO SECOND ROW FILL.
  - DESIGNED FOR USE WITH A .062 OR .093 THICK PCB
  - ASSEMBLIES TO BE PACKAGED IN TRAYS.
  - CENTER WELD TABS ARE NOT AVAILABLE ON -020 POSITION.
  - USE -Z- DATUM ZONE ONLY FOR MEASUREMENTS.

UNLESS OTHERWISE SPECIFIED, DIMENSIONS ARE IN INCHES.  
TOLERANCES ARE:  
DECIMALS ANGLES  
.XX: ±.01 [0.3]  
.XXX: ±.005 [0.13]  
.XXXX: ±.0020 [0.051]

PROPRIETARY NOTE  
THIS DOCUMENT CONTAINS CONFIDENTIAL AND PROPRIETARY INFORMATION AND ALL DESIGN, MANUFACTURING, REPRODUCTION, USE, PATENT RIGHTS AND SALES RIGHTS ARE EXPRESSLY RESERVED BY SAMTEC, INC. THIS DOCUMENT SHALL NOT BE DISCLOSED, IN WHOLE OR PART, TO ANY UNAUTHORIZED PERSON OR ENTITY NOR REPRODUCED, TRANSFERRED OR INCORPORATED IN ANY OTHER PROJECT IN ANY MANNER WITHOUT THE EXPRESS WRITTEN CONSENT OF SAMTEC, INC.



520 PARK EAST BLVD., NEW ALBANY, IN 47150  
PHONE: 812-944-6733 FAX: 812-948-5047  
e-Mail info@SAMTEC.com code 55322

MATERIAL: DO NOT SCALE DRAWING SHEET SCALE: 3:2  
INSULATOR: LCP, COLOR: BLACK  
TERMINAL, GROUND PLANE & WELD TAB: PHOS BRONZE

DESCRIPTION:  
.50mm DOUBLE ROW RIGHT ANGLE SOCKET STRIP

DWG. NO.  
**QSH-XXX-XX-X-D-DP-RA-XXX**

BY: GP 11/14/2013 SHEET 1 OF 6

TABLE 2			
No OF POSITIONS	COPLANARITY	STRAIGHTNESS ROW 1	STRAIGHTNESS ROW 1
-020 THRU -060	.004[0.10]	.004[0.10]	.004[0.10]

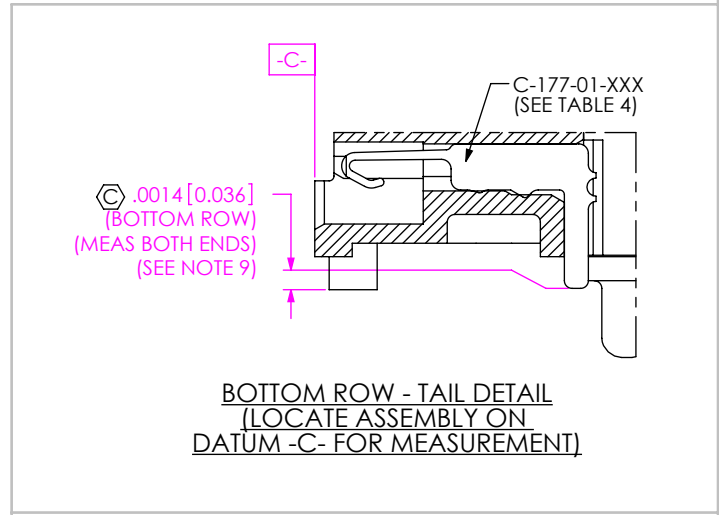
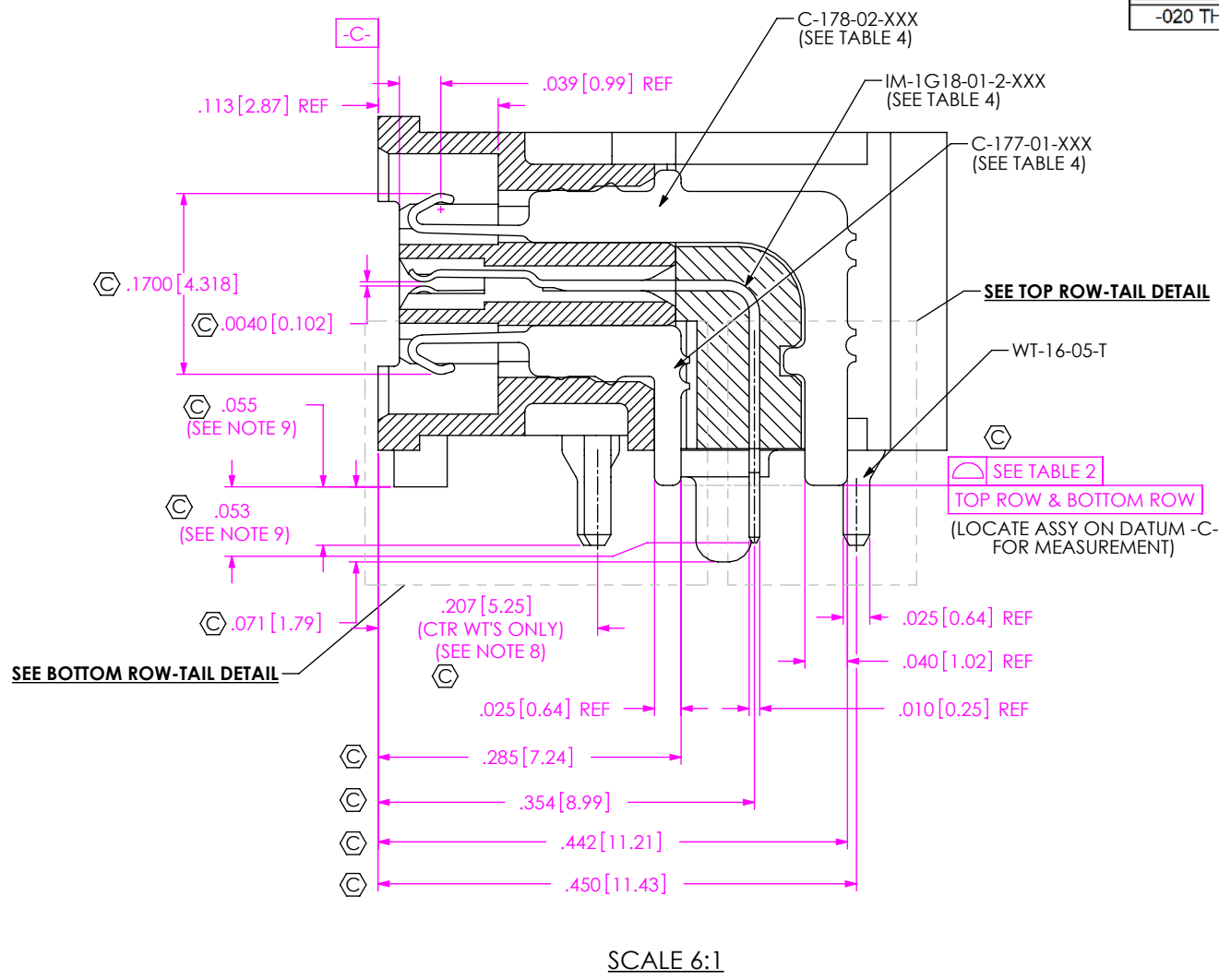

**BOTTOM ROW - TAIL DETAIL**  
(LOCATE ASSEMBLY ON DATUM -C- FOR MEASUREMENT)

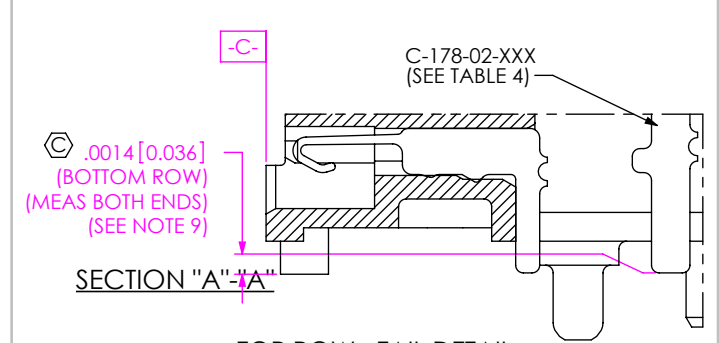

**TOP ROW - TAIL DETAIL**  
(LOCATE ASSEMBLY ON DATUM -C- FOR MEASUREMENT)

C:\EnterpriseVault\DWG\MISC\MKTG\QSH-XXX-XX-X-D-DP-RA-XXX-MKT.SLDDRW

**TABLE 4: PLATING SPECIFICATIONS**

	C-177-01-XXX CONTACT	C-178-02-XXX CONTACT	IM-1G18-01-2-XXX GROUND PLANE	WT-16-05-T WELD TAB
-F	3 - 5µ" FLASH GOLD ON CONTACT, MATTE TIN TAIL	3 - 5µ" FLASH GOLD CONTACT, MATTE TIN TAIL	3µ" MIN FLASH GOLD CONTACT, MATTE TIN TAIL	MATTE TIN
-L	10µ" MIN LIGHT GOLD CONTACT, MATTE TIN TAIL	10µ" MIN LIGHT GOLD CONTACT, MATTE TIN TAIL	10µ" MIN LIGHT GOLD CONTACT, MATTE TIN TAIL	MATTE TIN

**PROPRIETARY NOTE**  
THIS DOCUMENT CONTAINS CONFIDENTIAL AND PROPRIETARY INFORMATION AND ALL DESIGN, MANUFACTURING, REPRODUCTION, USE, PATENT RIGHTS AND SALES RIGHTS ARE EXPRESSLY RESERVED BY SAMTEC, INC. THIS DOCUMENT SHALL NOT BE DISCLOSED, IN WHOLE OR PART, TO ANY UNAUTHORIZED PERSON OR ENTITY NOR REPRODUCED, TRANSFERRED OR INCORPORATED IN ANY OTHER PROJECT IN ANY MANNER WITHOUT THE EXPRESS WRITTEN CONSENT OF SAMTEC, INC.

DO NOT SCALE DRAWING

SHEET SCALE: 6:1



520 PARK EAST BLVD. NEW ALBANY, IN 47150  
PHONE: 812-944-6733 FAX: 812-948-5047  
e-Mail info@SAMTEC.com code 55322

DESCRIPTION:  
.50mm DOUBLE ROW RIGHT ANGLE SOCKET STRIP

DWG. NO.  
QSH-XXX-XX-X-D-DP-RA-XXX

BY: GP 11/14/2013 SHEET 2 OF 6

**INSPECTION VIEW 1**  
(FILL BOTTOM ROW)

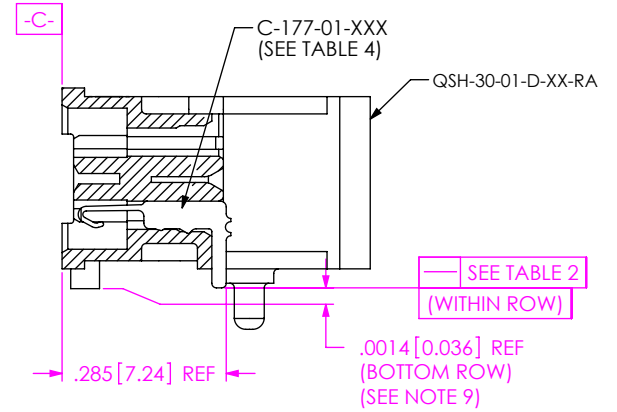
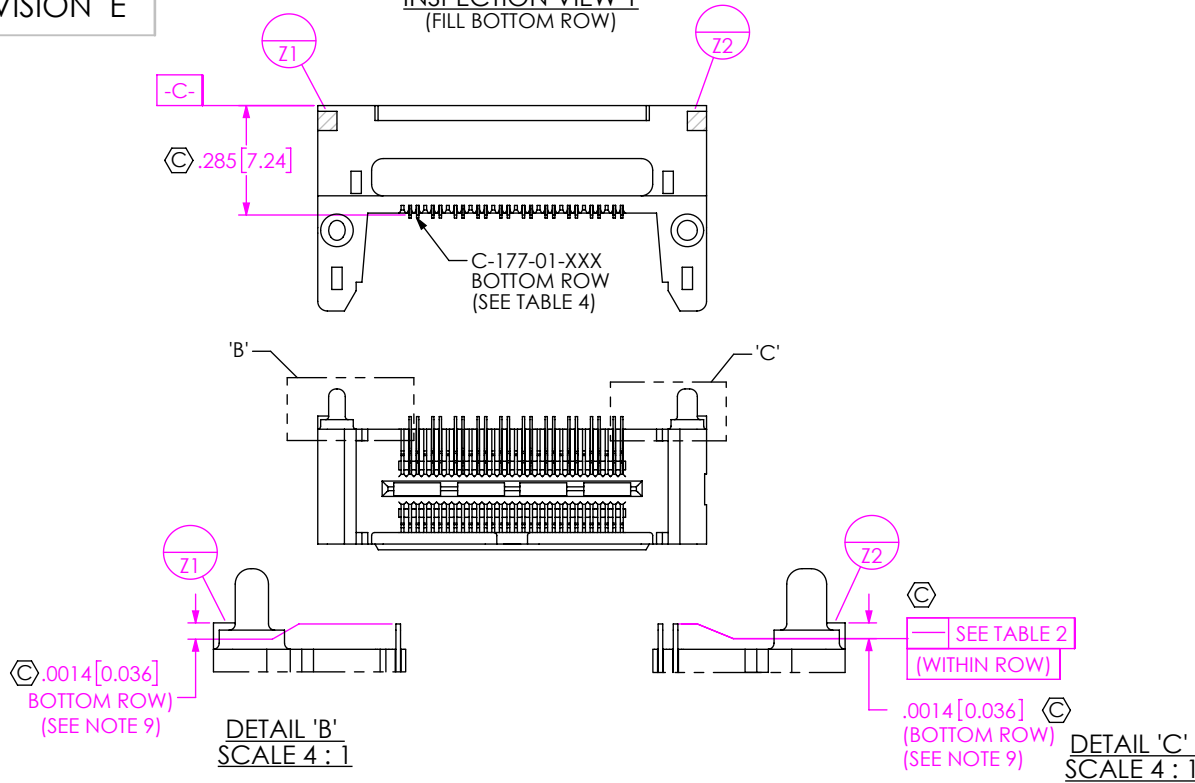

**IN-PROCESS 1**  
(FILL BOTTOM ROW)  
(SEE INSPECTION VIEW 1 FOR ORIENTATION AND CPC'S)

**INSPECTION VIEW 2**  
(FILL IM-1G18)

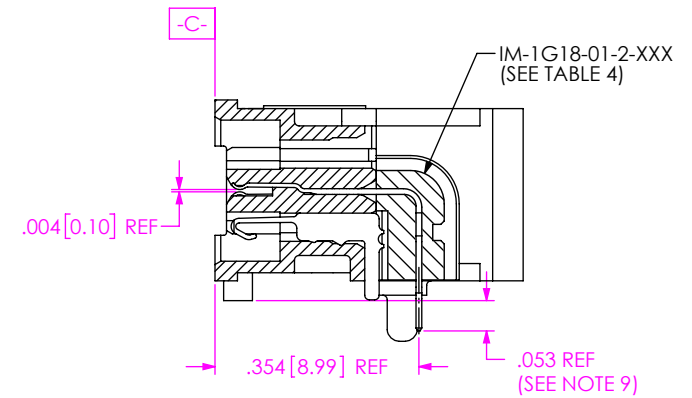
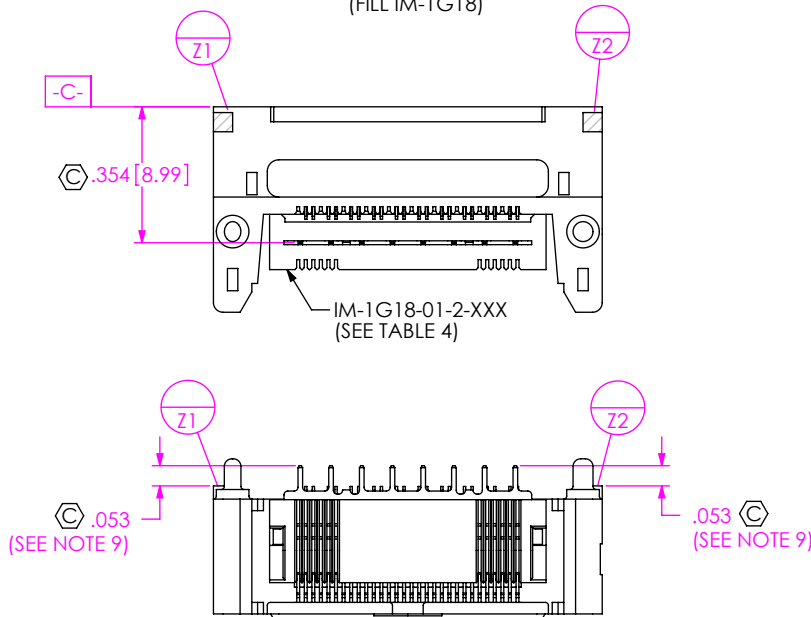

**IN-PROCESS 2**  
(FILL IM-1G18)  
(SEE INSPECTION VIEW 2 FOR ORIENTATION AND CPC'S)

**PROPRIETARY NOTE**  
THIS DOCUMENT CONTAINS CONFIDENTIAL AND PROPRIETARY INFORMATION AND ALL DESIGN, MANUFACTURING, REPRODUCTION, USE, PATENT RIGHTS AND SALES RIGHTS ARE EXPRESSLY RESERVED BY SAMTEC, INC. THIS DOCUMENT SHALL NOT BE DISCLOSED, IN WHOLE OR PART, TO ANY UNAUTHORIZED PERSON OR ENTITY NOR REPRODUCED, TRANSFERRED OR INCORPORATED IN ANY OTHER PROJECT IN ANY MANNER WITHOUT THE EXPRESS WRITTEN CONSENT OF SAMTEC, INC.

DO NOT SCALE DRAWING

SHEET SCALE: 6:1



520 PARK EAST BLVD, NEW ALBANY, IN 47150  
PHONE: 812-944-6733 FAX: 812-948-5047  
e-Mail: info@SAMTEC.com code 55322

DESCRIPTION:  
**.50mm DOUBLE ROW RIGHT ANGLE SOCKET STRIP**

DWG. NO.  
**QSH-XXX-XX-X-D-DP-RA-XXX**

BY: GP 11/14/2013 SHEET 3 OF 6

INSPECTION VIEW 3  
(FILL TOP ROW)

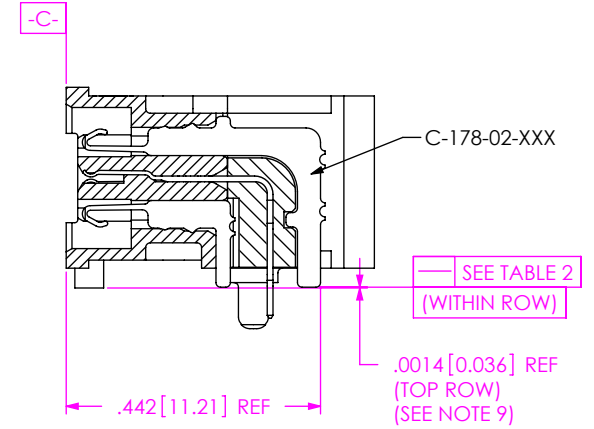
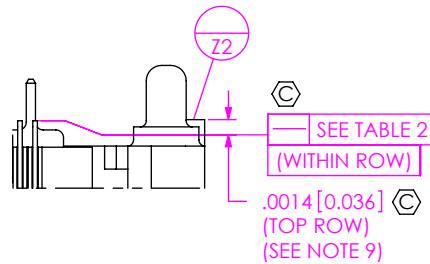
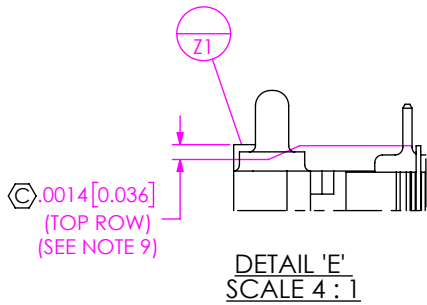
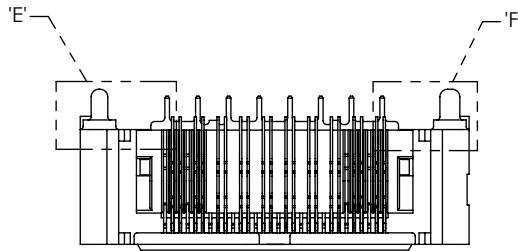
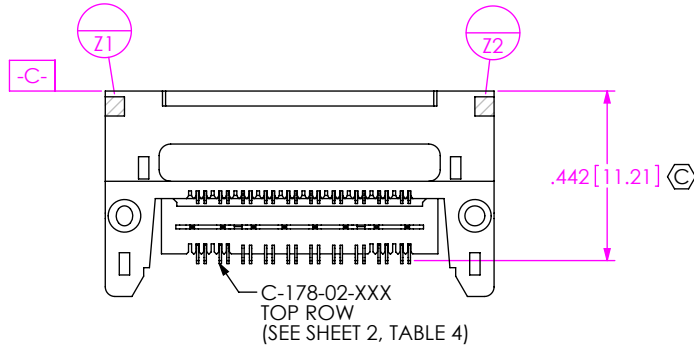
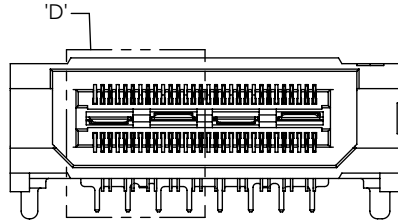

IN-PROCESS 3  
(FILL TOP ROW)  
(SEE INSPECTION VIEW 3 FOR ORIENTATION AND CPC'S)

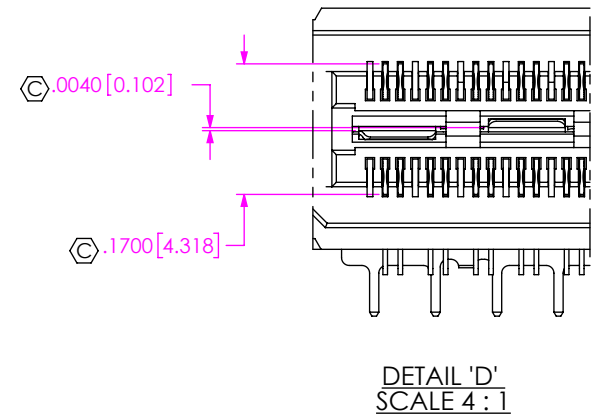

**PROPRIETARY NOTE**  
THIS DOCUMENT CONTAINS CONFIDENTIAL AND PROPRIETARY INFORMATION AND ALL DESIGN, MANUFACTURING, REPRODUCTION, USE, PATENT RIGHTS AND SALES RIGHTS ARE EXPRESSLY RESERVED BY SAMTEC, INC. THIS DOCUMENT SHALL NOT BE DISCLOSED, IN WHOLE OR PART, TO ANY UNAUTHORIZED PERSON OR ENTITY NOR REPRODUCED, TRANSFERRED OR INCORPORATED IN ANY OTHER PROJECT IN ANY MANNER WITHOUT THE EXPRESS WRITTEN CONSENT OF SAMTEC, INC.



520 PARK EAST BLVD, NEW ALBANY, IN 47150  
PHONE: 812-944-6733 FAX: 812-948-5047  
e-Mail: info@SAMTEC.com code 55322

DESCRIPTION:  
.50mm DOUBLE ROW RIGHT ANGLE SOCKET STRIP

DWG. NO.  
QSH-XXX-XX-X-D-DP-RA-XXX

BY: GP 11/14/2013 SHEET 4 OF 6

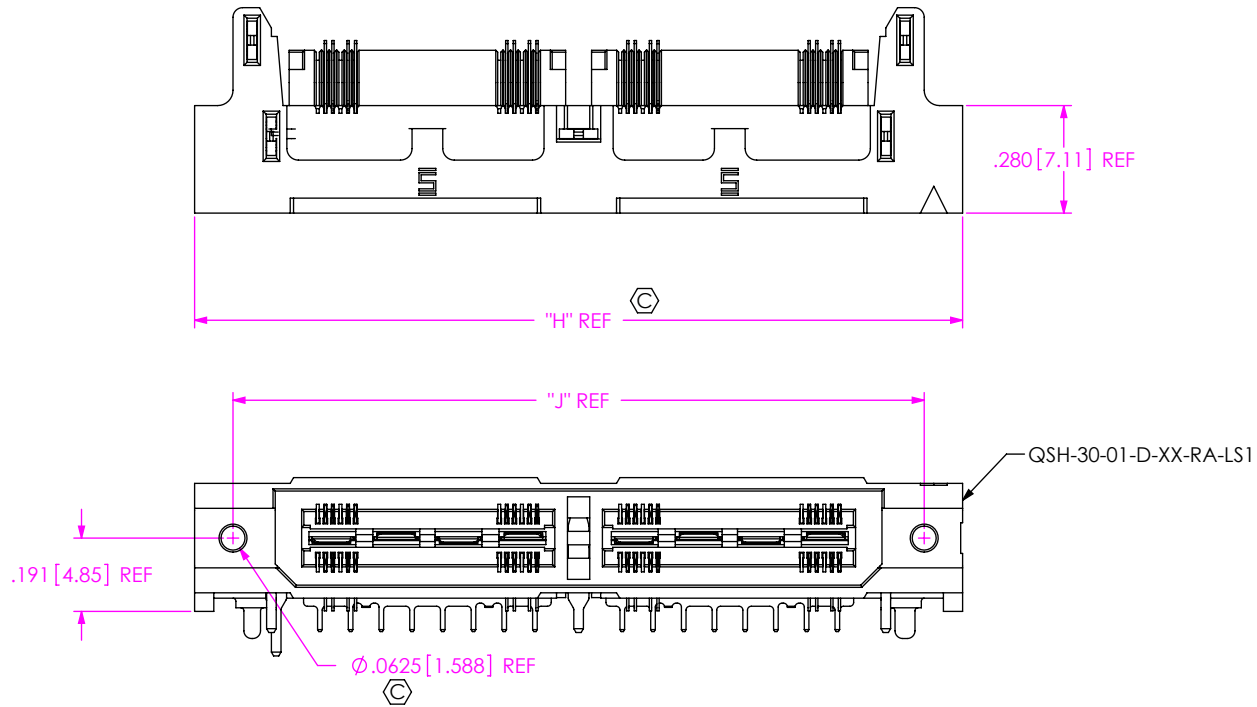

FIG 2  
 QSH-040-01-X-D-DP-RA-LS1 SHOWN  
 (SAME AS FIG 1, EXCEPT AS SHOWN)  
 (NOT TOOLED)

TABLE 5		
NO OF POS	"H"	"J"
-20	1.213 [30.80]	1.013 [25.72]
-40	2.000 [50.80]	1.800 [45.72]
-60	2.788 [70.80]	2.588 [65.72]

**PROPRIETARY NOTE**  
 THIS DOCUMENT CONTAINS CONFIDENTIAL AND PROPRIETARY INFORMATION AND ALL DESIGN, MANUFACTURING, REPRODUCTION, USE, PATENT RIGHTS AND SALES RIGHTS ARE EXPRESSLY RESERVED BY SAMTEC, INC. THIS DOCUMENT SHALL NOT BE DISCLOSED, IN WHOLE OR PART, TO ANY UNAUTHORIZED PERSON OR ENTITY NOR REPRODUCED, TRANSFERRED OR INCORPORATED IN ANY OTHER PROJECT IN ANY MANNER WITHOUT THE EXPRESS WRITTEN CONSENT OF SAMTEC, INC.

DO NOT SCALE DRAWING

SHEET SCALE: 2:1



520 PARK EAST BLVD, NEW ALBANY, IN 47150  
 PHONE: 812-944-6733 FAX: 812-948-5047  
 e-Mail info@SAMTEC.com code 55322

DESCRIPTION:  
 .50mm DOUBLE ROW RIGHT ANGLE SOCKET STRIP

DWG. NO.  
**QSH-XXX-XX-X-D-DP-RA-XXX**

BY: GP 11/14/2013 SHEET 5 OF 6

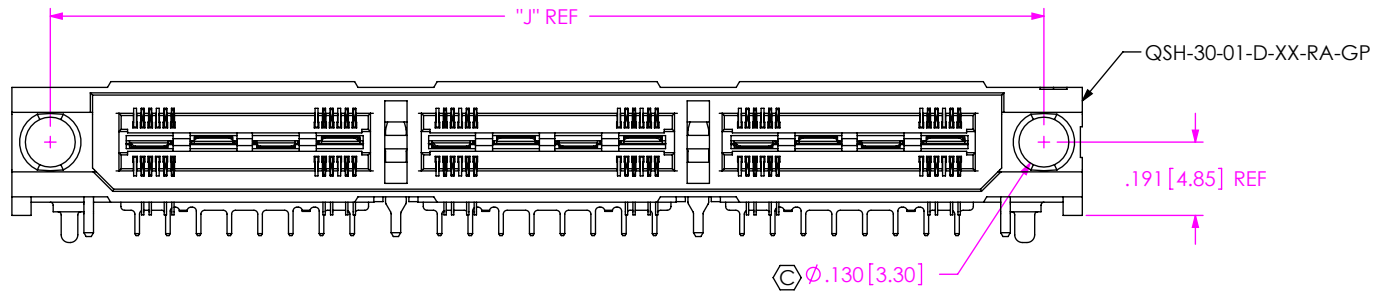
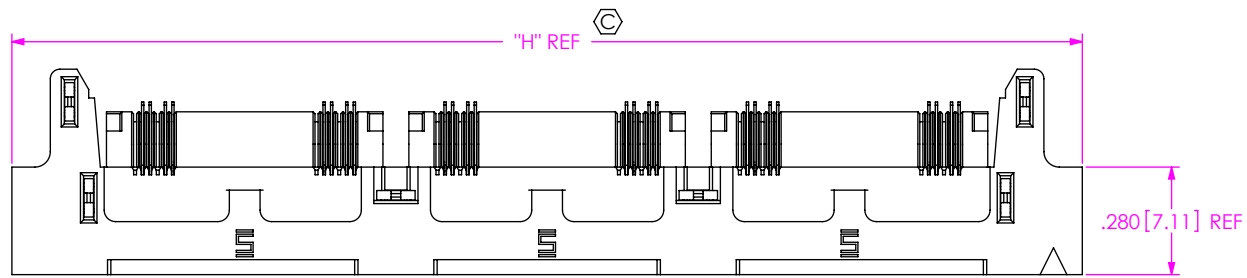

FIG 3  
QSH-060-01-X-D-DP-RA-GP SHOWN  
(SAME AS FIG 1, EXCEPT AS SHOWN)

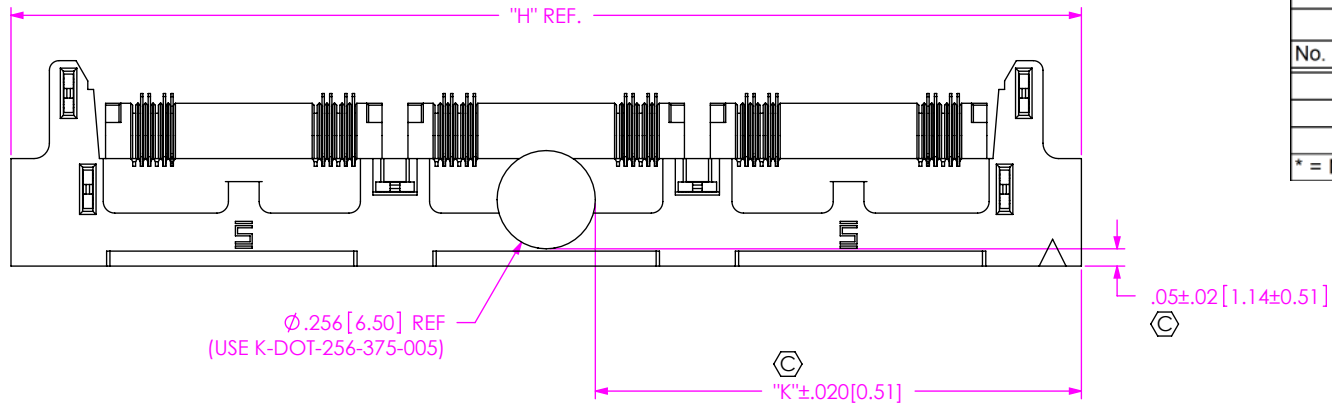

FIG 4  
QSH-060-01-X-D-DP-RA-GP-K SHOWN  
(SAME AS FIG 1, EXCEPT AS SHOWN)

TABLE 6		
No. OF POS	"K"	
	GP, & *LS1	NO GUIDE POST
-20	.478 [12.14]	.378 [9.60]
-40	.872 [22.15]	.772 [19.61]
-60	1.266 [32.16]	1.166 [29.62]

\* = NOT TOOLED

**PROPRIETARY NOTE**  
THIS DOCUMENT CONTAINS CONFIDENTIAL AND PROPRIETARY INFORMATION AND ALL DESIGN, MANUFACTURING, REPRODUCTION, USE, PATENT RIGHTS AND SALES RIGHTS ARE EXPRESSLY RESERVED BY SAMTEC, INC. THIS DOCUMENT SHALL NOT BE DISCLOSED, IN WHOLE OR PART, TO ANY UNAUTHORIZED PERSON OR ENTITY NOR REPRODUCED, TRANSFERRED OR INCORPORATED IN ANY OTHER PROJECT IN ANY MANNER WITHOUT THE EXPRESS WRITTEN CONSENT OF SAMTEC, INC.

DO NOT SCALE DRAWING  
SHEET SCALE: 2:1



520 PARK EAST BLVD, NEW ALBANY, IN 47150  
PHONE: 812-944-6733 FAX: 812-948-5047  
e-Mail info@SAMTEC.com code 55322

DESCRIPTION:  
.50mm DOUBLE ROW RIGHT ANGLE SOCKET STRIP  
DWG. NO.  
QSH-XXX-XX-X-D-DP-RA-XXX  
BY: GP 11/14/2013 SHEET 6 OF 6