

Description

An extremely versatile range of rocker switch/thermal circuit breakers (S-type TO CBE to EN 60934 with trip free mechanism) offering the choice of single pole, double pole with single pole protection, and double pole with protection on both poles. Designed for snap-in panel mounting with versions available for different panel cut-out sizes. Illumination is optional and there is a range of colours and markings for the rocker. Under overload conditions the rocker returns to the OFF position. 6way frame for 3120-F5 available upon request.

Any one of the following additional function modules can be supplied factory fitted to the rear of the switch/circuit breaker.

- Under voltage release coil (for double pole versions only).
- Magnetic trip coil for short circuit protection.
- Magnetic trip coil for remote relay trip.
- Auxiliary contacts for status signalling.
- Mechanical slide interlock.

Approved to CBE standard EN 60934 (IEC 60934).

Typical applications

Motors, transformers, solenoids, extra low voltage wiring systems, office machines, electro-medical equipment, power supplies, communications systems.

Standard current ratings and typical internal resistance values

Current rating (A)	Internal resistance per pole (Ω)	Current rating (A)	Internal resistance per pole (Ω)
0.1	94	3.5	0.0565
0.2	24	4	0.0435
0.3	12	4.5	0.0435
0.4	5.30	5	0.0325
0.5	4.20	6	0.0215
0.6	2.90	7	0.0165
0.8	1.50	8	0.0165
1	0.9	10	<0.02
1.2	0.80	12	<0.02
1.5	0.45	14	<0.02
2	0.27	16	<0.02
2.5	0.0785	18	< 0.02
3	0.0595	20	< 0.02

Approvals

Authority	Voltage ratings	Current ratings
VDE, Semko (EN 60934)	AC 240 V, DC 28 V DC 50 V DC 50 V	0.1...20 A 0.1...20 A double pole 0.1...10 A single pole
LRoS, BV	AC 250 V, DC 28 V	0.1...20 A
UL, CSA	AC 250 V, DC 50 V	0.1...20 A

single pole two poles in parallel up to 30A

Illumination voltage/power consumption

operating voltage	power consumption	
	filament/neon	LED
6 V	60 mA	9 mA
12 V	20 mA	9 mA
24 V	20 mA	9 mA
48 V	20 mA	1,5 mA
115 V	< 1 mA	
230 V	< 1 mA	



3120-F...

Technical data

Voltage rating	AC 240 V; DC 50 V (AC 250 V UL/CSA)		
Current ratings	0.1...20 A (up to 30 A to special order, single pole only)		
Typical life	50,000 operations for $I_N \leq 16$ A double pole 30,000 operations for $I_N \leq 16$ A single pole, 10,000 operations for $I_N > 16$ A		
Ambient temperature	-30...+60 °C (-22...+140 °F)		
Insulation co-ordination (IEC 60664 and 60664A)	Rated impulse withstand voltage 2.5 kV reinforced insulation in operating area	Pollution degree 2	
Dielectric strength (IEC 60664 and 60664A) operating area between poles (2 pole)	Test voltage AC 3,000 V AC 1,500 V		
Insulation resistance	>100 MΩ (DC 500 V)		
Interrupting capacity I_{cn}	0.1...2 A 2.5...20 A	10 x I_N 250 A 2 pole, or 150 A 1 pole	
Interrupting capacity (UL 1077)	I_N 0.1... 2 A 2.5... 3 A 3.5... 8 A 9 ... 16 A 18... 20 A 0.1...20 A	U_N AC 250 V AC 250 V AC 250 V AC 250 V AC 250 V DC 50 V	2 pole 200 A 1,000 A 2,000 A 3,500 A 5,000 A 1,000 A
Degree of protection (IEC 60529/DIN 40050)	operating area IP 40 (IP 54 with water splash protection) terminal area IP 00		
Vibration	8 g (57-500 Hz), ±0.61 mm (10-57 Hz) to IEC 60068-2-6, Test Fc 10 frequency cycles/axis		
Shock	30 g (11 ms) to IEC 60068-2-27, Test Ea		
Corrosion	96 hours at 5 % salt mist, to IEC 60068-2-11, Test Ka		
Humidity	240 hours at 95 % RH, to IEC 60068-2-3, Test Ca		
Mass	approx. 33 g (double pole) approx. 27 g (single pole)		

All dimensions without tolerances are for reference only. In the interest of improved design, performance and cost effectiveness the right to make changes in these specifications without notice is reserved. Product markings may not be exactly as the ordering codes. Errors and omissions excepted.

Ordering information

3120 rocker switch/circuit breaker

F snap in frame

3	to fit mounting cut-out 50.5x21.5 mm	1-6.35 mm (.039-.250 in)
4	to fit mounting cut-out 44.5x22 mm	1-2.5 mm (.039-.099 in)
5	to fit mounting cut-out 44.5x 22 mm	2.6-4 mm (.102-.158 in)
6	to fit mounting cut-out 45x33.7 mm	1.2-2.4 mm (.047-.094 in)

0	2 pole, unprotected, switch only
1	1 pole, thermally protected
2	2 pole, thermally protected
5	2 pole, thermally protected on one pole only (terminals 11, 12k, 12l)
6	1 pole, unprotected, switch only

1	collar height 1 mm (.040 in)
3	collar height 9 mm (.354 in)
4	collar height 2 mm with water splash protection (IP 54), not with -F6...

P7	blade terminals 2x2.8x0.8 mm (QC 2x.110) (terminals 12(k), 22(k), 11, 21), not for under voltage module, not for switch
H7	12(k), 22(k): blade terminals 2x2.8-0.8 (QC 2x.110) 11, 21: terminal screws, not for switch
N7	as P7, but including shunt terminals 12(i) and 22 (i) as blade terminals 2x2.8x0.8 mm(QC 2x.110) not for under voltage module
G7	as H7, but including shunt terminals 12(i) and 22 (i) as blade terminals 2x2.8x0.8 mm(QC 2x.110)

T1	thermal, 1.01-1.4 x I _N
Q1	switch only

W	rocker
U	momentary switch action

opaque	translucent
	(for illuminated versions)
01 black	12 white
02 white	14 red
04 red	15 orange
	19 green

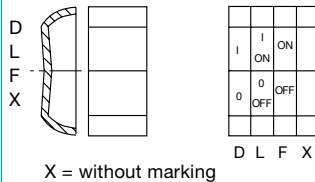

B	filament ≤ 48V AC/DC; neon ≥ 115V AC
G	green LED, AC/DC = 24V AC/DC
Y	yellow LED, AC/DC
R	red LED, AC/DC

0	4 - 7 V (B,G,Y,R)
1	10 - 14 V (B,G,Y,R)
2	20 - 28 V (B,G,Y,R)
3	90 - 140 V (B)
4	185 - 275 V (B)
5	42 - 54 V (B,Y,R)

0.1...20 A

3120 - F 3 2 1 - N7 T1 - W 14 D B 4 - 5 A ordering example

3120 - F . 0 . - N7 Q1 - W - 20 A (switch only)

NOTE:

Switch only versions must be specified with -N7 or -G7 terminals.
Terminals 12(k) and 22(k) are not fitted.

Typical time/current characteristics

Single or double pole load

0.1...2 A

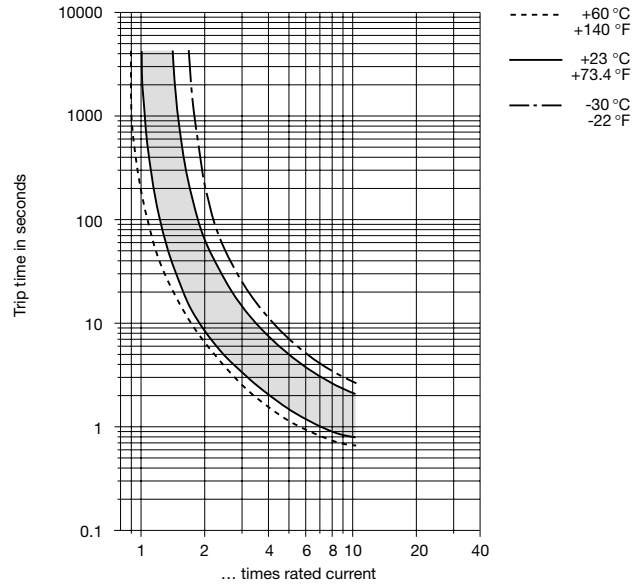

2.5...20 A

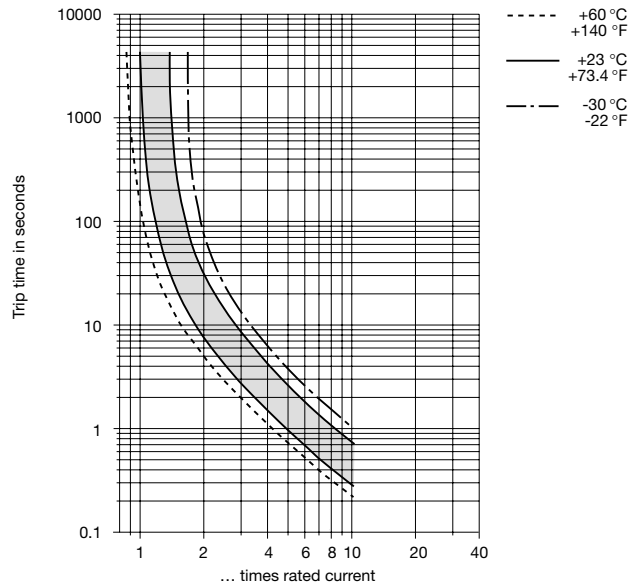

The time/current characteristic curve depends on the ambient temperature prevailing. In order to eliminate nuisance tripping, please multiply the circuit breaker current ratings by the derating factor shown below. See also section 9 - Technical information.

Ambient temperature °F	-22	-4	+14	+32	+73.4	+104	+122	+140
°C	-30	-20	-10	0	+23	+40	+50	+60
Multiplication factor	0.8	0.76	0.84	0.92	1	1.08	1.16	1.24

Internal connection diagrams

2 pole,
thermally protected on both poles

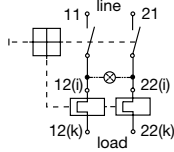

2 pole,
thermally protected on one pole only

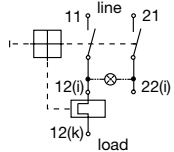

1 pole,
thermally protected

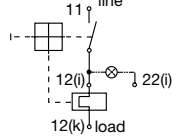

2 pole,
unprotected

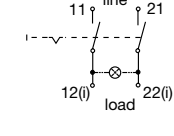

Dimensions

Style F3.1
collar height 1 mm

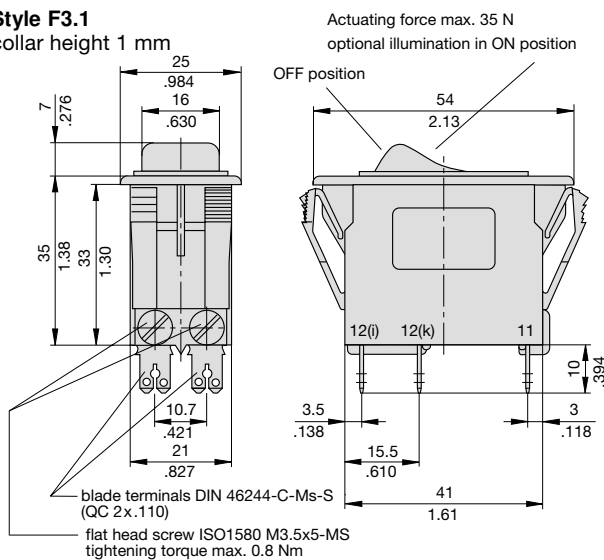

Installation drawing

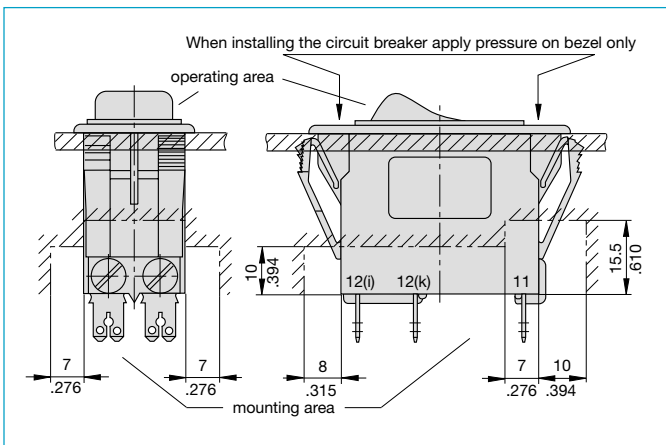

This is a metric design and millimeter dimensions take precedence ($\frac{mm}{inch}$)

Mounting style variants

Style F 3.3 collar height 9 mm (.354 in.)

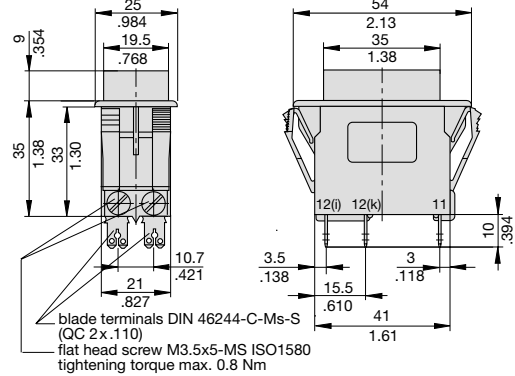

Style F 3.4
collar height 2 mm (.079 in.), with water splash protection

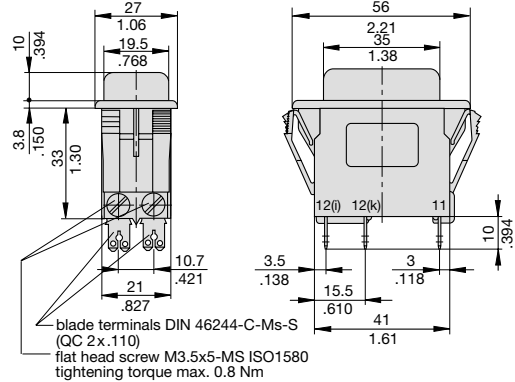

Style F 4.1

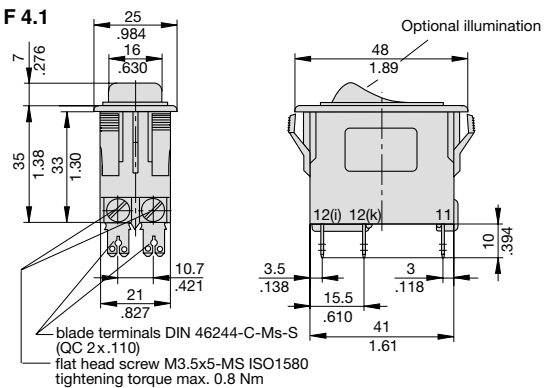

Style F 5.1

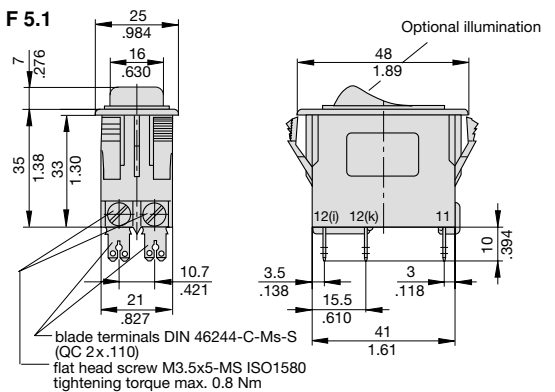

Dimension diagram for style F6 is available on request.

Accessories

Insulated cover Y 303 068 01

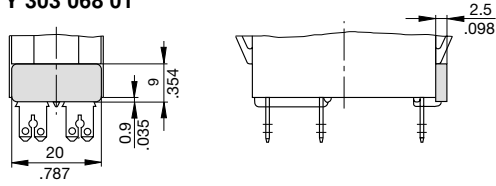

Terminal adapter Y 303 862 01

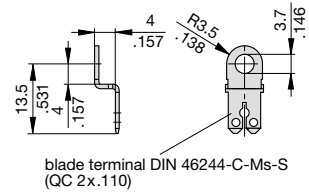

Retaining clip for 3120-F3... Y 303 675 01/02

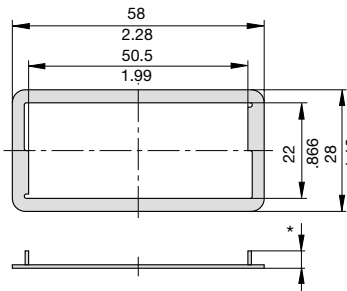

* Y 303 675 01 suitable for panel thickness < 2 mm (.079 in)
* Y 303 675 02 suitable for panel thickness < 4 mm (.157 in)

Retaining clip for 3120-F5... Y 303 676 01

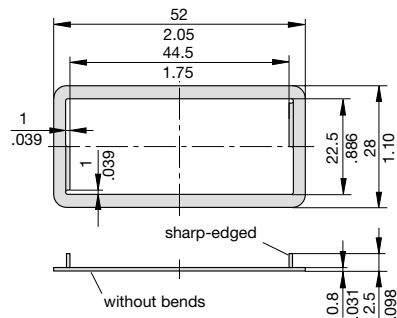

Blanking piece in -F3 frame Y 303 885 31

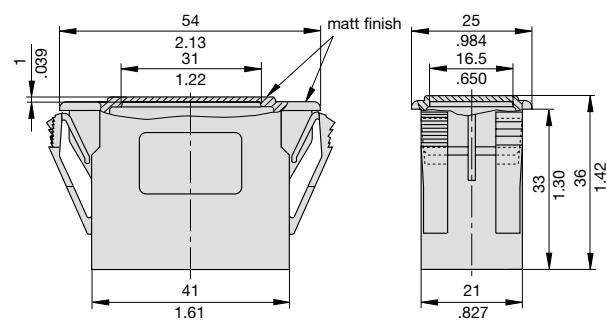

Rear terminal shroud black Y 304 275 01 (IP64)

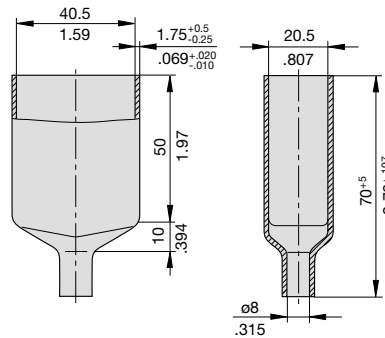

Water splash cover, transparent (IP66) for styles -F4.../-F5... X 221 619 01

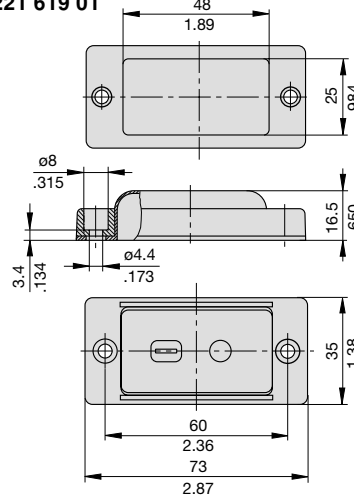

Cut-out dimensions

Cut-out for mounting style -F3 with rocker and push button

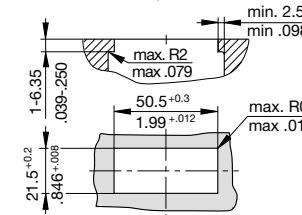

Cut-out for mounting style -F6 with rocker

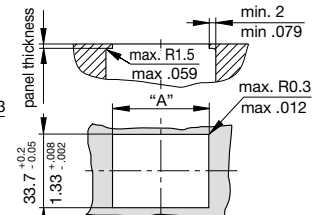

Cut-out for mounting style -F4/-F5 with rocker

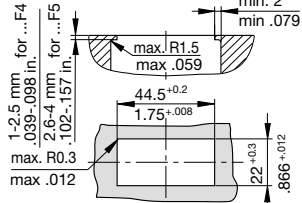

panel thickness	mm	1.2 +0.4	1.6 +0.8	2.4 +1
	inch	.047 +0.016	.063 +0.031	.094 +0.039
dimension	mm	45 +0.2 / -0.05	45 +1.1 / -0.05	45 +2.2 / -0.05
"A"	inch	1.77 +0.008 / -0.002	1.77 +0.043 / -0.002	1.77 +0.087 / -0.002

Edges of working parts: DIN 6784

This is a metric design and millimeter dimensions take precedence ($\frac{mm}{inch}$)

Description

Switch/thermal trip free circuit breaker (S-type TO CBE to EN 60934) with standard isolator style two button operation. Single button press-to-reset version also available. Both types can be supplied in single pole configuration only, in double pole with single pole protection, and in double pole with protection on both poles. Designed for snap-in panel mounting. There is a choice of push button colour combinations and illumination is optional.

Any one of the following additional function modules can be supplied factory fitted to the rear of the switch/circuit breaker:

- Under voltage release coil (for double pole versions only).
- Magnetic trip coil for short circuit protection.
- Magnetic trip coil for remote relay trip.
- Auxiliary contacts for status signalling.
- Mechanical slide interlock.

Approved to CBE standard EN 60934 (IEC 60934).



3120-F...

Standard current ratings and typical internal resistance values

Current rating (A)	Internal resistance per pole (Ω)	Current rating (A)	Internal resistance per pole (Ω)
0.1	94	3.5	0.0565
0.2	24	4	0.0435
0.3	12	4.5	0.0435
0.4	5.30	5	0.0325
0.5	4.20	6	0.0215
0.6	2.90	7	0.0165
0.8	1.50	8	0.0165
1	0.9	10	<0.02
1.2	0.80	12	<0.02
1.5	0.45	14	<0.02
2	0.27	16	<0.02
2.5	0.0785	18	< 0.02
3	0.0595	20	< 0.02

Approvals

Authority	Voltage ratings	Current ratings
VDE, Semko (EN 60934)	AC 240 V, DC 28 V	0.1...20 A
	DC 50 V	0.1...20 A double pole
	DC 50 V	0.1...10 A single pole
LRoS, BV	AC 250 V, DC 28 V	0.1...20 A
UL, CSA	AC 250 V, DC 50 V	0.1...20 A

single pole two poles in parallel up to 30 A

Illumination voltage/power consumption

operating voltage	power consumption	
	filament/neon	LED
6 V	60 mA	9 mA
12 V	20 mA	9 mA
24 V	20 mA	9 mA
48 V	20 mA	1,5 mA
115 V	< 1 mA	
230 V	< 1 mA	

Technical data

Voltage rating	AC 240 V; DC 50 V (AC 250 V UL/CSA)		
Current ratings	0.1...20 A (up to 30 A to special order, single pole only)		
Typical life	50,000 operations for $I_N \leq 16$ A double pole 30,000 operations for $I_N \leq 16$ A single pole, 10,000 operations for $I_N > 16$ A		
Ambient temperature	-30...+60 °C (-22...+140 °F)		
Insulation co-ordination (IEC 60664 and 60664A)	Rated impulse withstand voltage 2.5 kV	Pollution degree 2	reinforced insulation in operating area
Dielectric strength (IEC 60664 and 60664A) operating area between poles (2 pole)	Test voltage AC 3,000 V	AC 1,500 V	
Insulation resistance	>100 M Ω (DC 500 V)		
Interrupting capacity I_{cn}	0.1...2 A	10 x I_N	
	2.5...20 A	250 A 2 pole, or 150 A 1 pole	
Interrupting capacity (UL 1077)	I_N	U_N	2 pole
	0.1... 2 A	AC 250 V	200 A
	2.5... 3 A	AC 250 V	1,000 A
	3.5... 8 A	AC 250 V	2,000 A
	9 ... 16 A	AC 250 V	3,500 A
	18... 20 A	AC 250 V	5,000 A
	0.1...20 A	DC 50 V	1,000 A
Degree of protection (IEC 60529/DIN 40050)	operating area IP 40 terminal area IP 00		
Vibration	8 g (57-500 Hz), ±0.61 mm (10-57 Hz) to IEC 60068-2-6, Test Fc 10 frequency cycles/axis		
Shock	30 g (11 ms) to IEC 60068-2-27, Test Ea		
Corrosion	96 hours at 5 % salt mist, to IEC 60068-2-11, Test Ka		
Humidity	240 hours at 95 % RH, to IEC 60068-2-3, Test Ca		
Mass	approx. 33 g (double pole) approx. 27 g (single pole)		

All dimensions without tolerances are for reference only. In the interest of improved design, performance and cost effectiveness the right to make changes in these specifications without notice is reserved. Product markings may not be exactly as the ordering codes. Errors and omissions excepted.

Ordering information

Type No.	
3120	push button switch/circuit breaker
Mounting	
F	snap in frame
Size of frame	
2	flange mounting, special frame for fitting splash cover
3	to fit mounting cut-out 50.5x21.5 mm (1.99x8.47 in) panel thickness 1-6.35 mm (.039-.250 in)
Number of poles	
0	2 pole, unprotected, switch only
1	1 pole, thermally protected
2	2 pole, thermally protected
5	2 pole, thermally protected on one pole only (terminals 11,12k,12l)
6	1 pole, unprotected, switch only
Mounting frame design	
F	with 2 push buttons
G	with 1 push button (press to reset only)
Terminal configuration	
P7	blade terminals 2x2.8x0.8mm (QC 2x.110) (terminals 12(k), 22(k), 11, 21), not for under voltage module, not for switch
H7	12(k), 22(k): blade terminals 2x2.8-0.8 (QC 2x.110) 11, 21: terminal screws, not for switch
N7	as P7, but including shunt terminals 12(i) and 22 (i) as blade terminals 2x2.8x0.8 mm (QC 2x.110) not for under voltage module
G7	as H7, but including shunt terminals 12(i) and 22 (i) as blade terminals 2x2.8x0.8 mm (QC 2x.110)
Characteristic curve	
T1	thermal, 1.01-1.4 I _n
Q1	switch only, only for N7 or G7 terminals
Switch style/colour	
D	1 push button (re-set only)
Z	1 push button (momentary switch)
01X	black
04X	red
12X	white translucent
19X	green translucent
S	2 push buttons on/off
GRX	green translucent/red
WRX	white translucent/red
WBX	white translucent/black
Push button illumination (optional)	
B	filament AC/DC
L	neon, AC
G	green LED, AC/DC= 24 V AC/DC
Y	yellow LED, AC/DC
R	red LED, AC/DC
Illumination voltage range	
0	4 - 7 V (B,G,Y,R)
1	10 - 14 V (B,G,Y,R)
2	20 - 28 V (B,G,Y,R)
3	90 - 140 V (L)
4	185 - 275 V (L)
5	42 - 54 V (B,Y,R)
Current ratings	
0.1...20 A	

3120	-	F	3	2	F	-	N7	T1	-	S	GRX	L	4	-	10 A	ordering example
3120	-	F	3	0	F	-	N7	Q1	-	S	-	20 A	switch only

NOTE:
Switch only versions must be specified with -N7 or -G7 terminals.
Terminals 12(k) and 22 (k) are not fitted.

Typical time/current characteristics

1 or 2 pole load
0.1...2 A

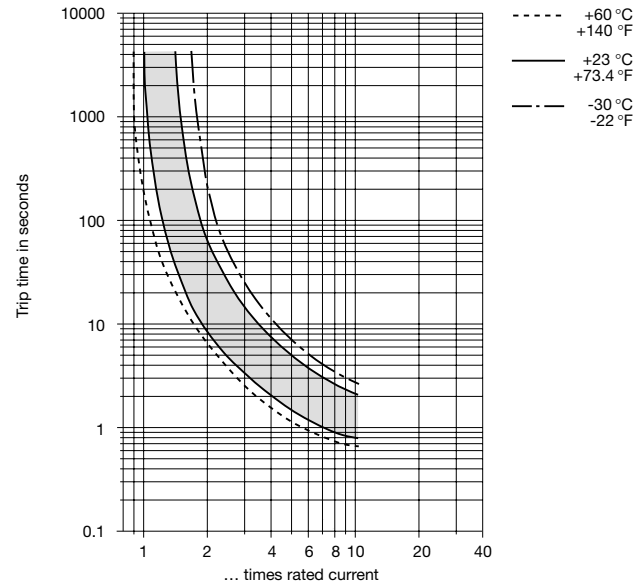

2.5...20 A

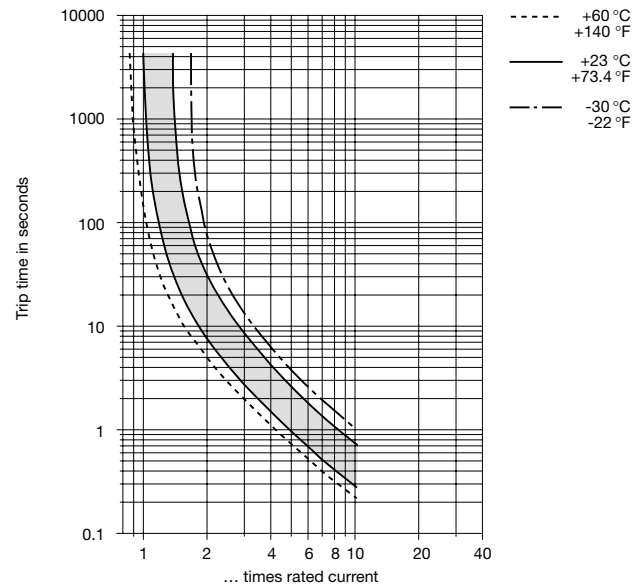

The time/current characteristic curve depends on the ambient temperature prevailing. In order to eliminate nuisance tripping, please multiply the circuit breaker current ratings by the derating factor shown below. See also section 9 – Technical information.

Ambient temperature °F	-22	-4	+14	+32	+73.4	+104	+122	+140
°C	-30	-20	-10	0	+23	+40	+50	+60
Multiplication factor	0.8	0.76	0.84	0.92	1	1.08	1.16	1.24

Dimensions

3120-F3.F-...-S...

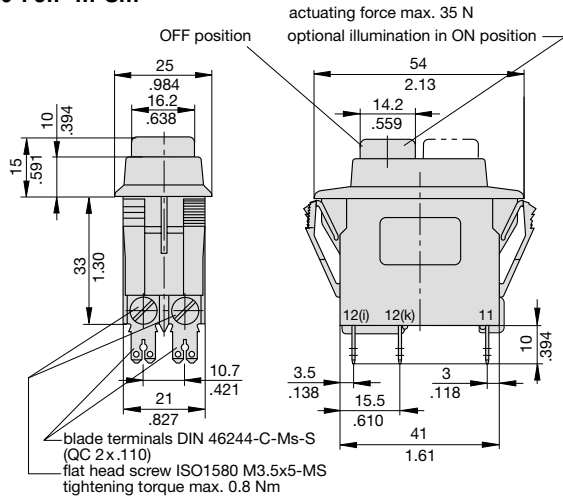

3120-F3.G-...-D...

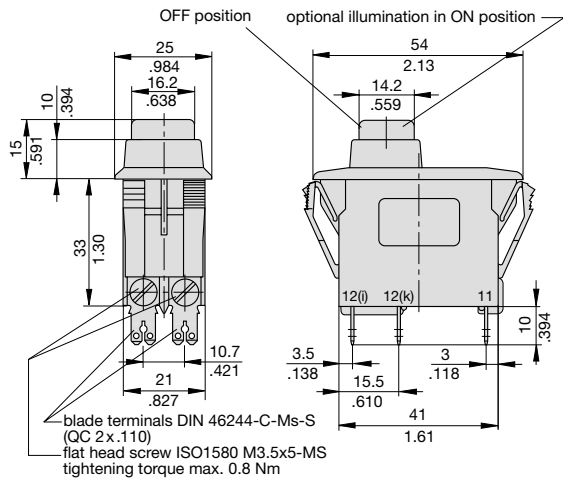

3120-F2.F-...

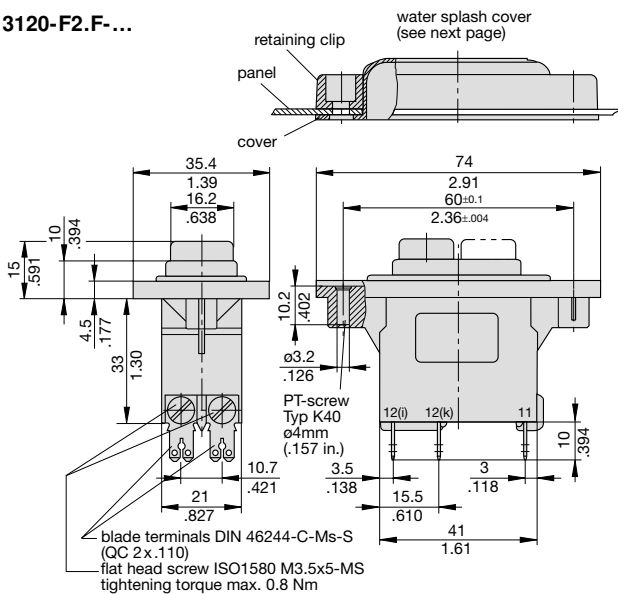

Internal connection diagrams

2 pole, thermally protected on both poles

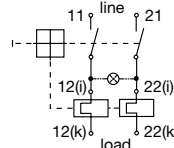

2 pole, thermally protected on one pole only

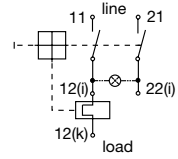

1 pole, thermally protected

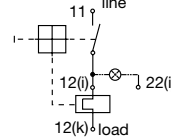

2 pole, unprotected

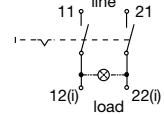

Installation drawing

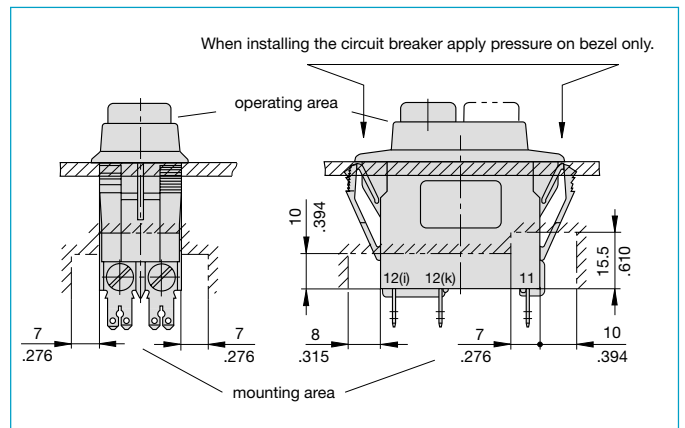

Panel cut-out

3120-F3...

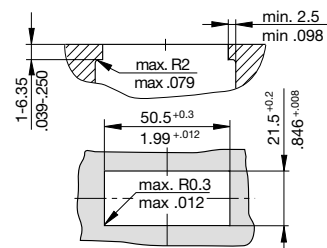

3120-F2...

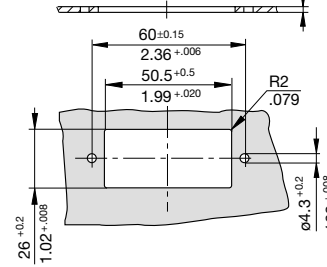

t: metal min. 2 mm (.079 in.)
plastic min. 3 mm (.118 in.)

Edges of working parts: DIN 6784

This is a metric design and millimeter dimensions take precedence ($\frac{mm}{inch}$)

Accessories

Insulated cover Y 303 068 01

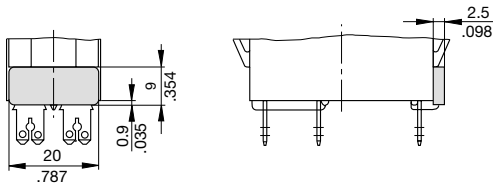

Terminal adapter Y 303 862 01

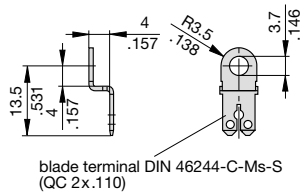

Retaining clip for 3120-F3... Y 303 675 01/02

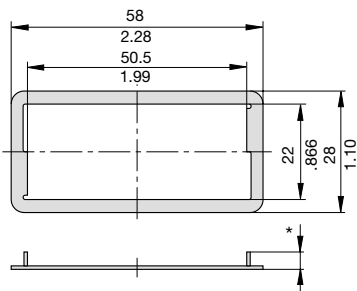

* Y 303 675 01 suitable for panel thickness < 2 mm (.079 in)
* Y 303 675 02 suitable for panel thickness < 4 mm (.157 in)

Blanking piece in -F3 frame Y 303 885 31

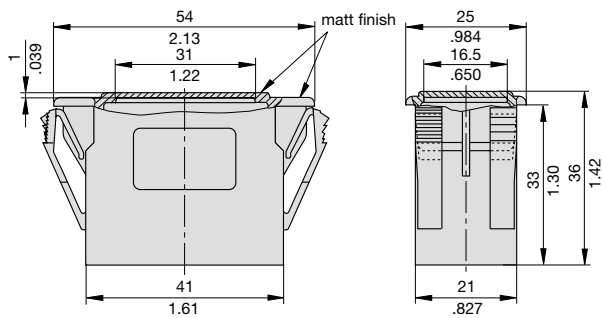

Rear terminal shroud black Y 304 275 01 (IP64)

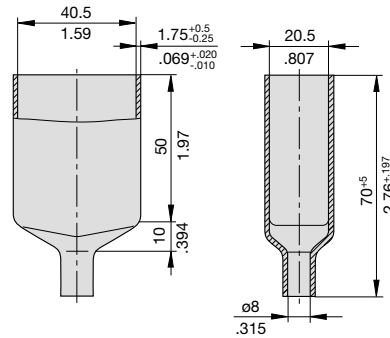

Water splash cover, transparent (IP66) for style 3120-F2.F-...

X 221 619 01

- retaining clip Y 306 551 01
- cover Y 306 001 01

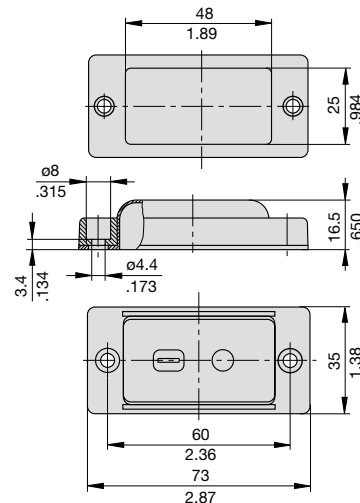

This is a metric design and millimeter dimensions take precedence ($\frac{mm}{inch}$)

Description

A module supplied factory fitted to type 3120-F to provide electrically separate changeover contacts which operate as the main contacts open/close. Ideally suited to status signalling and sequence switching.

Typical applications

Monitoring of the switching position of the circuit breaker or any connected load.

Ordering information

Type No.		
X3120	Module for type 3120 and type 3140	
Function		
S	auxiliary contact module	
Contact configuration		
0	change-over contact	
Terminal design		
1	blade terminals 2.8 x 0.5 (QC .110), silver plated	
Contact rating		
AC		
Voltage rating	Current rating	
A 10-250 V	0.1...4 A	
	12 V	0.1...4 A
	24 V	0.1...4 A
	60 V	0.1...1 A
	110 V	0.1...0.5 A
B 5-250 V	0.05...1 A	
	220 V	0.1...0.25 A
5-250 V	0.05...1 A	
Supply condition		
M	module mounted to circuit breaker 3120-../3140	

X3120 - S 0 1 A M ordering example

Approvals (complete circuit breaker/module assembly)

Authority	Voltage ratings	Current ratings
VDE (EN 60934)	AC 250 V, DC 28 V	0.05...4 A
UL, CSA	AC 250 V	0.05...4 A

All dimensions without tolerances are for reference only. In the interest of improved design, performance and cost effectiveness the right to make changes in these specifications without notice is reserved. Product markings may not be exactly as the ordering codes. Errors and omissions excepted.

Dimensions

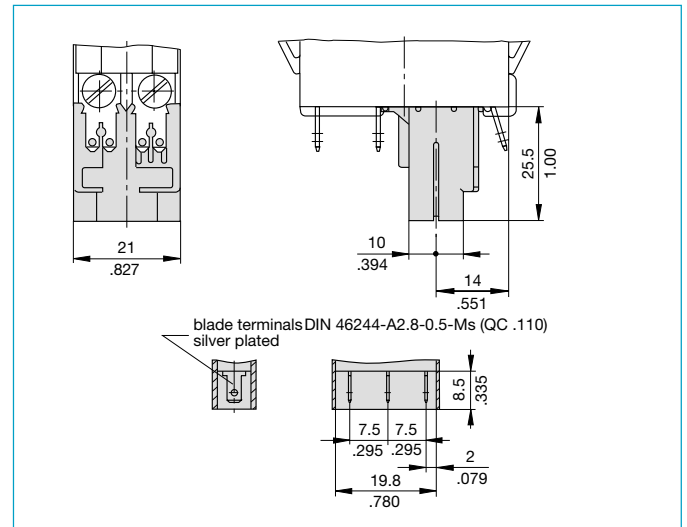

Internal connection diagram

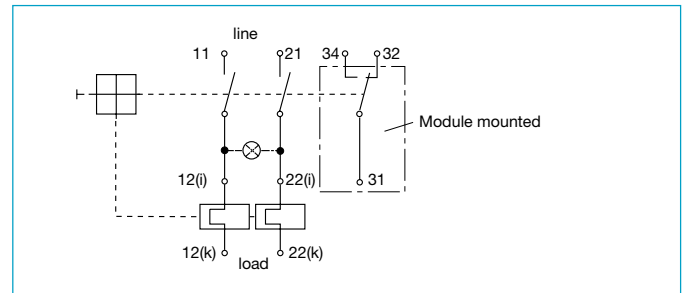

Technical data

	A	B
Voltage rating	AC 250 V; DC 220 V	AC/DC 250 V
Current rating	0.1...4 A /	0.05...1 A
Typical life	50,000 operations	
Ambient temperature	-30...+60 °C (-22...140 °F)	
Dielectric strength (IEC 60664 and 60664A) between main and auxiliary circuit	Test voltage AC 3,000 V	
Insulation resistance	> 100 MΩ (DC 500 V)	
Vibration	6 g (type X3120-S...A) 8 g (type X3120-S...B) (57-500 Hz), ±0.46 mm (10-57 Hz) to IEC 60068-2-6, test Fc 10 frequency cycles/axis	
Shock	15 g (11 ms), type X3120-S...A 20 g (11 ms), type X3120-S...B to IEC 60068-2-27, test Ea	
Corrosion	96 hours at 5 % salt mist, to IEC 60068-2-11, test Ka	
Humidity	240 hours at 95 % RH to IEC 60068-2-30, test Ca	
Mass	approx. 38 g (complete assembly)	

This is a metric design and millimeter dimensions take precedence ($\frac{mm}{inch}$)

Description

A module suitable for all double pole versions of type 3120-F to trip the main switch/circuit breaker mechanism in the event of loss of voltage. When the voltage is restored the rocker switch must be reset to reconnect the load, thereby avoiding the safety hazards associated with automatic re-starting of machinery.

Note: Basic unit 3120-...-H7 or -G7 screw terminals necessary.

Typical applications

Machines such as power tools, industrial equipment and domestic appliances where automatic restart after restoration of power could be dangerous (EU Machinery Directive)

Dimensions

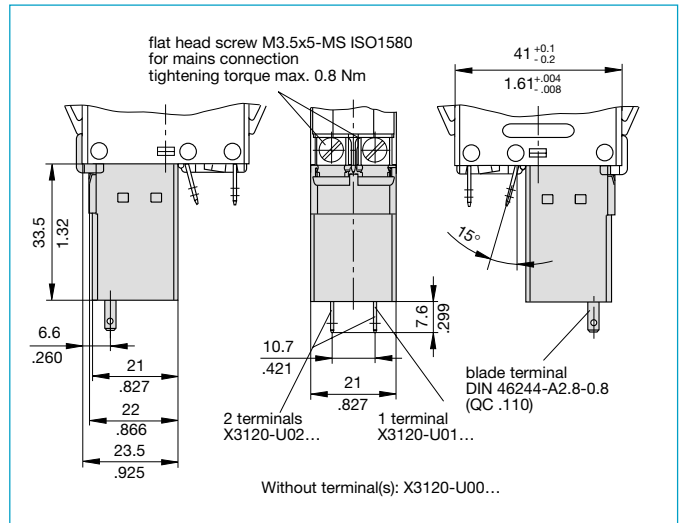

Ordering information

Type No.	
X3120	Module for type 3120
Function	
U	undervoltage release module
Terminal design	
00	standard (without separate connections)
01	1 blade terminal 2.8x0.8 (QC .110)
02	2 blade terminals 2.8x0.8 (QC .110)
Voltage ratings	
00	230/240 V AC 50/60 Hz
01	120 V AC 50/60 Hz
02	100 V AC 50/60 Hz
03	24 V DC
M	module mounted to the circuit breaker 3120

X3120 - U 00 00 M ordering example

Internal connection diagrams

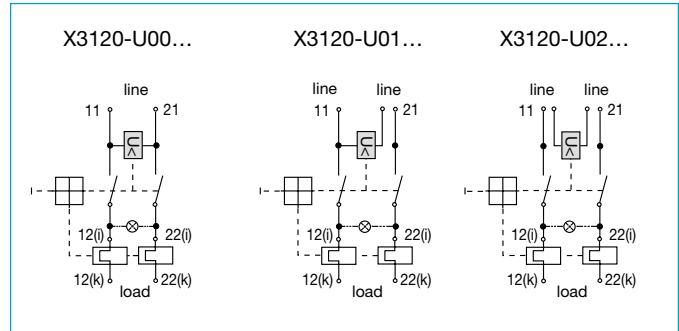

Technical data

Voltage ratings	AC 100, 120 V, 230/240 V 50/60 Hz DC 24 V
Voltage tolerance	+10%/-15%
Current consumption	approx. 2.5 mA
Typical life	20,000 operations
Release values	$0.2 \times U_N < U < 0.7 \times U_N$ (at a rated voltage of AC 100 V the device may release at 70 V and must release at 20 V)
Release delay	$t < 20$ ms
Latch-in values	$\geq 85 \% U_N$
Ambient temperature	-30...+60 °C (-22...+140 °F)
Vibration	8 g (57-500 Hz) ± 0.61 mm (10-57 Hz) to IEC 60068-2-6, test Fc 10 frequency cycles/axis
Shock	30 g (11 ms) to IEC 60068-2-27, test Ea
Corrosion	48 hours at 5 % salt mist, to IEC 60068-2-11, test Ka
Humidity	240 hours at 95% RH to IEC 60068-2-30, test Ca
Mass	approx. 53 g (complete assembly)

This is a metric design and millimeter dimensions take precedence ($\frac{mm}{inch}$)

All dimensions without tolerances are for reference only. In the interest of improved design, performance and cost effectiveness the right to make changes in these specifications without notice is reserved. Product markings may not be exactly as the ordering codes. Errors and omissions excepted.

Description

A module which adds remote trip capability to all versions of type 3120-F. A voltage applied across the coil, by means of an external sensor for example, will cause disconnection of the main switch/circuit breaker mechanism.

Typical applications

Electrical monitoring of safety systems, remote trip.

Ordering information

Type No.	
X3120	Module for type 3120
Function	
M	magnetic relay trip module
Style	
2	magnetic remote trip coil
Terminal design	
P7	blade terminals 2 x 2.8 x 0.8 (QC 2x.110) tin plated
Supply condition	
M	module mounted to the circuit breaker
Trip Voltage ratings	
AC 12/24/48/60/120/240 V	
DC 12/24 V	

X3120 - M 2 P7 M - 12 V ordering example

Standard voltage ratings and typical internal resistance values

Voltage rating (V)	Internal resistance per pole (Ω)
12 V AC/DC	0.78
24 V AC/DC	3.3
48 V AC	11.9
60 V AC	18.5
120 V AC	71.0

Approvals (complete circuit breaker/module assembly)

Authority	Voltage ratings
VDE (EN 60934)	AC 12...240 V; DC 12...24 V
UL, CSA	AC 12...240 V; DC 12...24 V

All dimensions without tolerances are for reference only. In the interest of improved design, performance and cost effectiveness the right to make changes in these specifications without notice is reserved. Product markings may not be exactly as the ordering codes. Errors and omissions excepted.

Dimensions

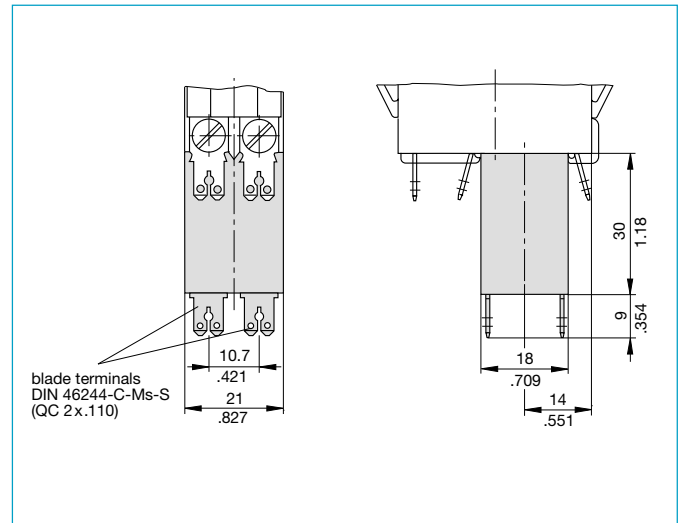

Internal connection diagram

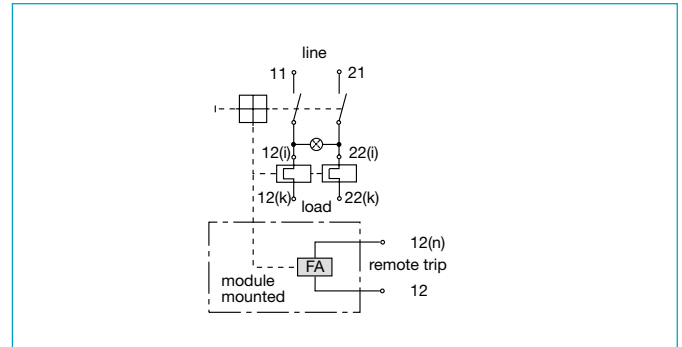

Technical data

Voltage ratings	AC 12...240 V; DC 12...24 V
Power consumption	approx. 200 W
Pulse operation	20 ms < t _{ON} < 100 ms / t _{OFF} > 10 sec
Release delay	t < 20 ms
Typical life	50,000 operations at U _N
Ambient temperature	-30...+60 °C (-22...+140 °F)
Dielectric strength (IEC 60664 and 60664A) between main circuit and trip coil circuit	Test voltage AC 3,000 V
Insulation resistance	>100 M Ω (DC 500 V)
Vibration	8 g (57-500 Hz) \pm 0.61 mm (10-57 Hz) to IEC 60068-2-6, test Fc 10 frequency cycles/axis
Shock	30 g (11 ms) to IEC 60068-2-27, test Ea
Corrosion	96 hours at 5 % salt mist, to IEC 60068-2-11, test Ka
Humidity	240 hours at 95 % RH to IEC 60068-2-30, test Ca
Mass	approx. 53 g (complete assembly)

This is a metric design and millimeter dimensions take precedence ($\frac{mm}{inch}$)

Description

Suitable for use with all type 3120-F versions, this module provides a mechanical safety interlock which, according to the option specified, prevents the main switch/circuit breaker mechanism from being reset/switched on. The actuator is intended for use with interlock systems to ensure that machinery cannot be operated without covers and safety guards in place, for instance.

Typical applications

Mechanical monitoring of safety systems, e.g. for garden shredders

Dimensions

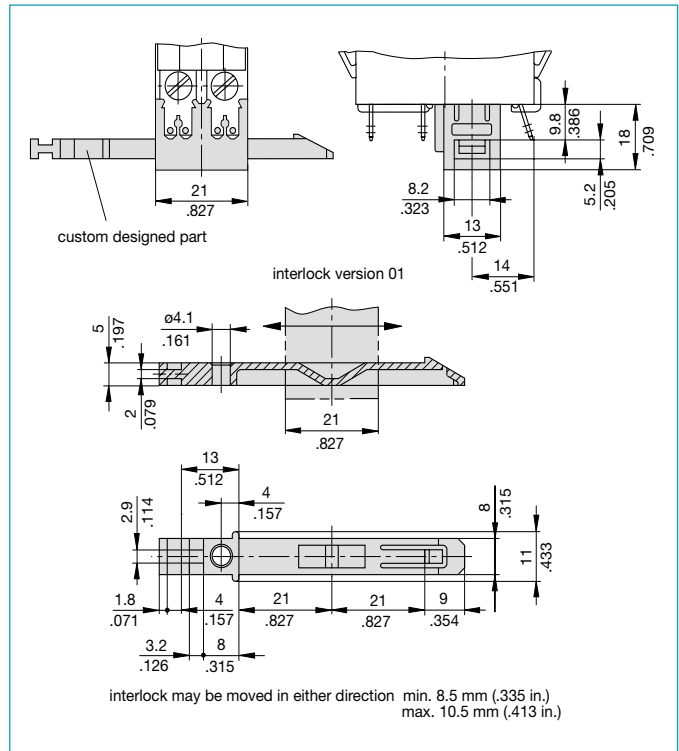

Ordering information

Type No.	
X3120	Module for type 3120-F
Function	
V	mechanical slide interlock module
Module operation	
1	3120 can only be switched on without the interlock fitted
Interlock design	
00	without interlock
01	interlock version 01 (see dimension diagram)
Delivery condition of interlock	
L	interlock supplied separately with the module
M	module factory-fitted with the interlock in its centre position
O	module supplied without interlock
Operating direction of interlock	
0	without interlock, or interlock supplied separately
1	interlock operated from the side near terminals 11, 12k, 12i of the 3120-...
2	interlock operated from the side near terminals 21, 22k, 22i of the 3120-...
Assembly status	
L	module supplied separately
M	module mounted to the circuit breaker

X3120 - V 1 00 O 0 M ordering example

All dimensions without tolerances are for reference only. In the interest of improved design, performance and cost effectiveness the right to make changes in these specifications without notice is reserved. Product markings may not be exactly as the ordering codes. Errors and omissions excepted.

This is a metric design and millimeter dimensions take precedence ($\frac{mm}{inch}$)