

THIS DRAWING IS UNPUBLISHED. RELEASED FOR PUBLICATION
 © COPYRIGHT BY TYCO ELECTRONICS CORPORATION. ALL RIGHTS RESERVED.

LOC	DIST	REVISIONS			
P	LTR	DESCRIPTION	DATE	DWN	APVD
FT	0				
	AL	REVISED PER 0G3B-1173-04	1/5/05	SS	GS
	AL1	REVISED PER ECO-09-021826	11JAN10	KK	AEG

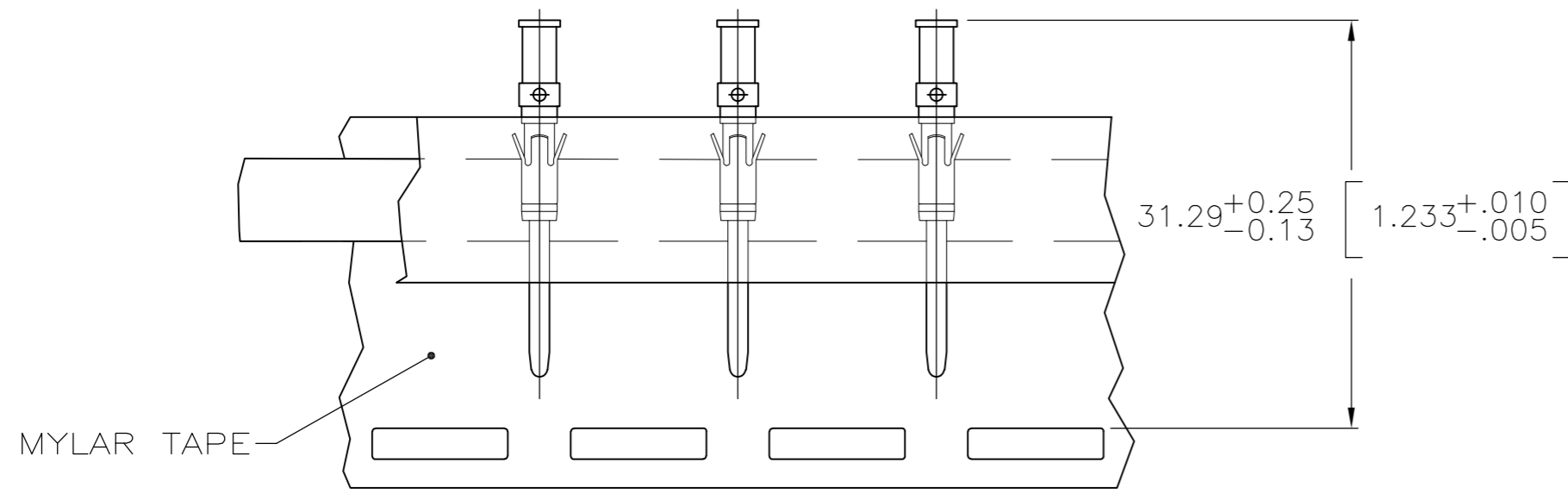
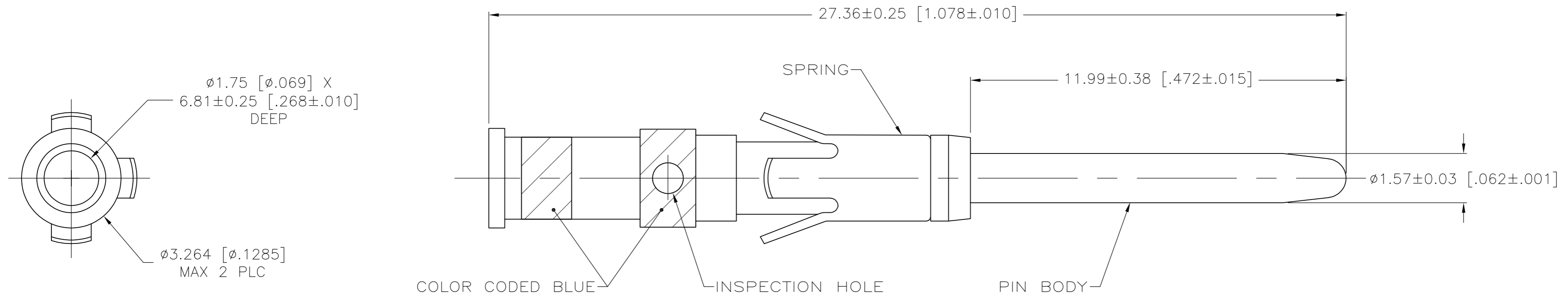

TAPE MTG DETAIL
SCALE 2:1

NOTES:

- ① 0.76um [.000030] MIN GOLD OVER 1.27um [.000050] MIN NICKEL.
- ② 1.27um [.000050] MIN TIN-LEAD OVER 1.2um [.000050] MIN NICKEL.
- ③ WHEN ORDERING CONTACT ASSEMBLY ON TAPE, ORDER BY THE TAPE NUMBER PLUS PACKAGING CODE AS FOLLOWS:
 - 1. FOR USE WITH AMP TAPETRONIC, PNEUMATIC TOOL
 - A. 1000 PARTS TO A BOX ADD PACKAGING CODE: 1MBOX
 - 2. FOR USE WITH 4/8 INDENT STRIPPER CRIMPER
 - A. 1000 PARTS TO A REEL ADD PACKAGING CODE: 1MREEL
 - B. 5000 PARTS TO A REEL ADD PACKAGING CODE: 5MREEL
- 4. CONTACT ACCEPTS 16-18 WIRE SIZE.
- ⑤ 7.62 um [.000300] MIN 60/40 MATTE TIN-LEAD OVER 1.27 um [.000050] MIN NICKEL.
- ⑥ 7.62um [.000300] MIN 93/7 TIN/LEAD OVER 1.27um [.000050] MIN NICKEL.
- ⑦ NO COLOR CODED BANDS.
- ⑧ 7.62um [.000300] MIN TIN OVER 1.27um [.000050] MIN NICKEL.
- ⑨ OBSOLETE PARTS: OBSOLETE CIS STREAMLINING PER D.RENAUD/D.SINISI

⑨	OBSOLETE	STANDARD	⑧ ⑦	1-200336-7
⑨	OBSOLETE	STANDARD	⑥ ⑦	1-200336-6
⑨	OBSOLETE	STANDARD	⑤ ⑦	1-200336-5
⑨	OBSOLETE	SMALL PACK	①	1-200336-4
⑨	OBSOLETE	STANDARD	②	1-200336-3
		TAPE MTG (SEE DETAIL) ③	①	200336-6
		STANDARD	①	200336-1
		PACKAGING TYPE	PIN BODY FINISH	PART NO.

THIS DRAWING IS A CONTROLLED DOCUMENT.		DWN	04/06/93	Tyco Electronics Corporation	
DIMENSIONS: MM		CHK	4-26-93	Harrisburg, PA 17105	
TOLERANCES UNLESS OTHERWISE SPECIFIED:		APVD	-	CONTACT ASSEMBLY, PIN, #16, TYPE II	
0 PLC	± -	PRODUCT SPEC	-	SIZE	CAGE CODE
1 PLC	± -	APPLICATION SPEC	-	A2	00779
2 PLC	± -	WEIGHT	-	DRAWING NO	
3 PLC	± -	FINISH	-	C=200336	
4 PLC	± -	PIN BODY: SEE TABLE	-	SCALE	SHEET
ANGLES	± -			10:1	1 OF 1
MATERIAL				CUSTOMER DRAWING	REV
PIN BODY: COPPER ALLOY					AL1
SPRING: STAINLESS STL					