



CY7C4425/4205/4215
CY7C4225/4235/4245

64/256/512/1K/2K/4K x 18 Synchronous FIFOs

Features

- High speed, low power, first-in first-out (FIFO) memories
- 64 x 18 (CY7C4425)
- 256 x 18 (CY7C4205)
- 512 x 18 (CY7C4215)
- 1K x 18 (CY7C4225)
- 2K x 18 (CY7C4235)
- 4K x 18 (CY7C4245)
- High speed 100 MHz operation (10 ns read/write cycle time)
- Low power ($I_{CC} = 45$ mA)
- Fully asynchronous and simultaneous read and write operation
- Empty, Full, Half Full, and Programmable Almost Empty/Almost Full status flags
- TTL compatible
- Retransmit function
- Output Enable (\overline{OE}) pin
- Independent read and write enable pins
- Center power and ground for reduced noise
- Supports free running 50% duty cycle clock inputs
- Width Expansion Capability
- Depth Expansion Capability
- Available in 64 pin 14 x 14 TQFP, 64 pin 10 x 10 TQFP, and 68-pin PLCC

Functional Description

The CY7C42X5 are high speed, low power, first-in first-out (FIFO) memories with clocked read and write interfaces. All are 18 bits wide and are pin/functionally compatible to IDT722X5. The CY7C42X5 can be cascaded to increase FIFO depth. Programmable features include Almost Full/Almost Empty flags. These FIFOs provide solutions for a wide variety of data buffering needs, including high speed data acquisition, multiprocessor interfaces, and communications buffering.

These FIFOs have 18-bit input and output ports that are controlled by separate clock and enable signals. The input port is controlled by a free-running clock (WCLK) and a write enable pin (WEN). When WEN is asserted, data is written into the FIFO on the rising edge of the WCLK signal. While WEN is held active, data is continually written into the FIFO on each cycle. The output port is controlled in a similar manner by a free-running read clock (RCLK) and a read enable pin (REN). In addition, the CY7C42X5 have an output enable pin (\overline{OE}). The read and write clocks may be tied together for single-clock operation or the two clocks may be run independently for asynchronous read/write applications. Clock frequencies up to 100 MHz are achievable.

Retransmit and Synchronous Almost Full/Almost Empty flag features are available on these devices.

Depth expansion is possible using the cascade input (\overline{WXI} , \overline{RXI}), cascade output (\overline{WXO} , \overline{RXO}), and First Load (\overline{FL}) pins. The \overline{WXO} and \overline{RXO} pins are connected to the \overline{WXI} and \overline{RXI} pins of the next device, and the \overline{WXO} and \overline{RXO} pins of the last device should be connected to the \overline{WXI} and \overline{RXI} pins of the first device. The \overline{FL} pin of the first device is tied to VSS and the \overline{FL} pin of all the remaining devices should be tied to VCC.

The CY7C42X5 provides five status pins. These pins are decoded to determine one of five states: Empty, Almost Empty, Half Full, Almost Full, and Full (see Table 2). The Half Full flag shares the \overline{WXO} pin. This flag is valid in the standalone and width-expansion configurations. In the depth expansion, this pin provides the expansion out (\overline{WXO}) information that is used to signal the next FIFO when it will be activated.

The Empty and Full flags are synchronous, i.e., they change state relative to either the read clock (RCLK) or the write clock (WCLK). When entering or exiting the Empty states, the flag is updated exclusively by the RCLK. The flag denoting Full states is updated exclusively by WCLK. The synchronous flag architecture guarantees that the flags will remain valid from one clock cycle to the next. As mentioned previously, the Almost Empty/Almost Full flags become synchronous if the VCC/SMODE is tied to VSS. All configurations are fabricated using an advanced 0.65 μ m N-Well CMOS technology. Input ESD protection is greater than 2001V, and latch-up is prevented by the use of guard rings.

Logic Block Diagram

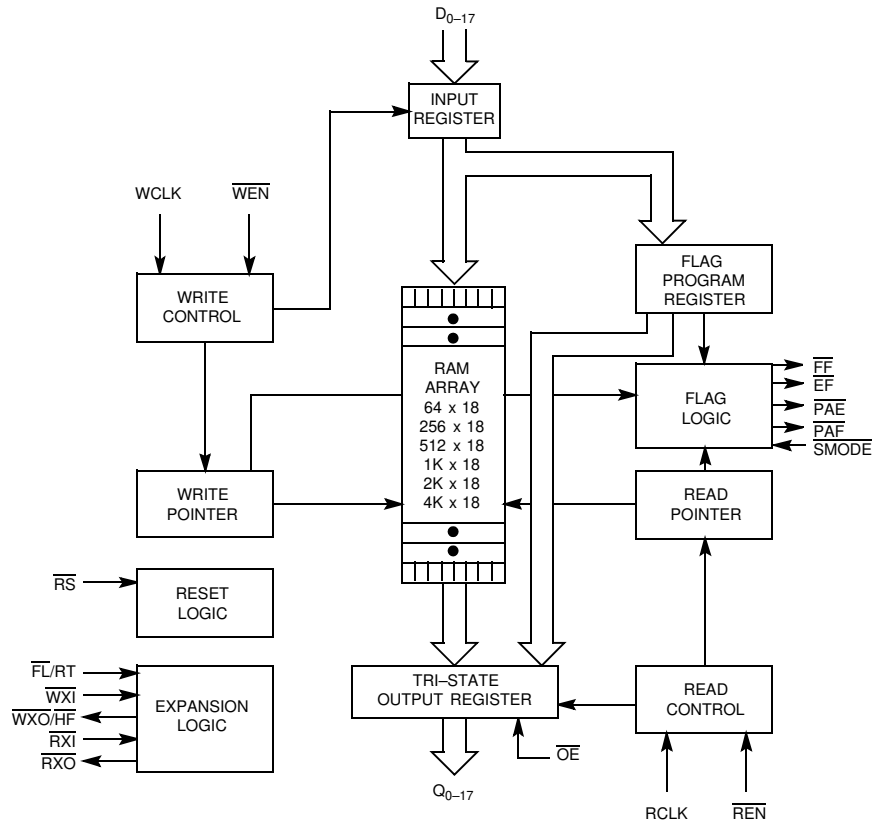

Pin Configuration

Figure 1. TQFP (Top View)

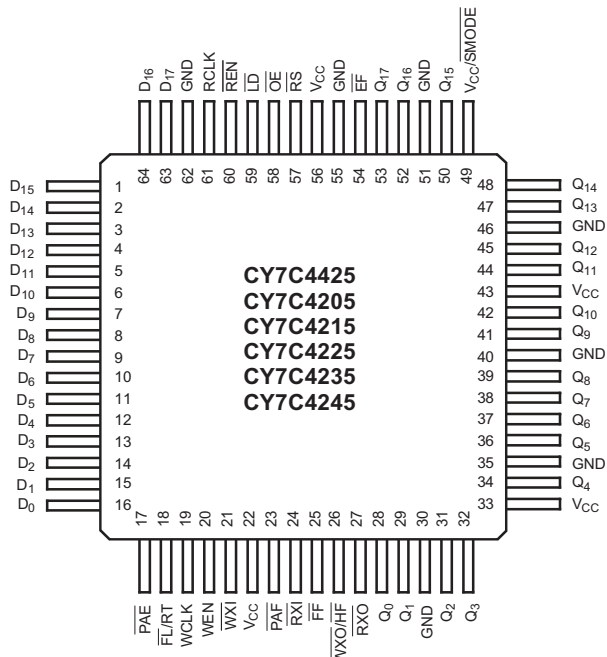
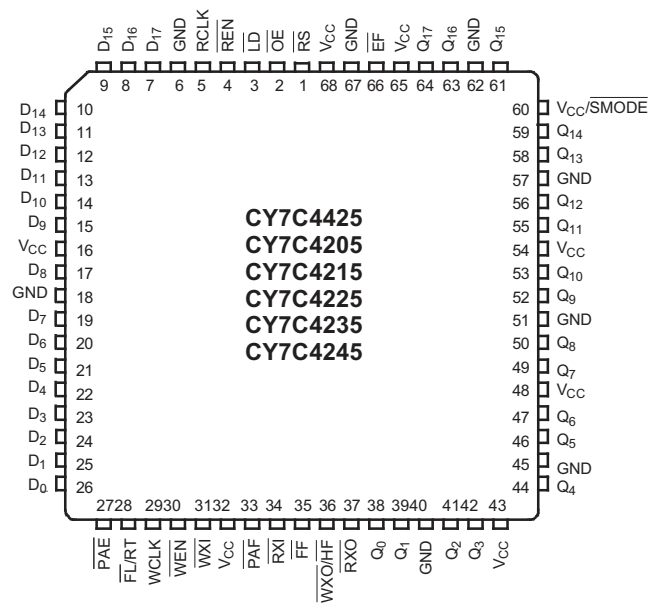

Figure 2. PLCC (Top View)



Selection Guide

Description		-10	-15	-25	-35
Maximum Frequency (MHz)		100	66.7	40	28.6
Maximum Access Time (ns)		8	10	15	20
Minimum Cycle Time (ns)		10	15	25	35
Minimum Data or Enable Set-Up (ns)		3	4	6	7
Minimum Data or Enable Hold (ns)		0.5	1	1	2
Maximum Flag Delay (ns)		8	10	15	20
Operating Current (Icc2) (mA) @ 20MHz	Commercial	45	45	45	45
	Industrial	50	50	50	50

Parameter	CY7C4425	CY7C4205	CY7C4215	CY7C4225	CY7C4235	CY7C4245
Density	64 x 18	256 x 18	512 x 18	1K x 18	2K x 18	4K x 18
Packages	64-pin TQFP (14 x 14, 10 x 10) 68-pin PLCC (10 x 10)	64-pin TQFP (14 x 14, 10 x 10) 68-pin PLCC (10 x 10)	64-pin TQFP (14 x 14, 10 x 10) 68-pin PLCC (10 x 10)	64-pin TQFP (14 x 14, 10 x 10) 68-pin PLCC (10 x 10)	64-pin TQFP (14 x 14, 10 x 10) 68-pin PLCC (10 x 10)	64-pin TQFP (14 x 14, 10 x 10) 68-pin PLCC (10 x 10)

Pin Definitions

Signal Name	Description	IO	Function
D ₀₋₁₇	Data Inputs	I	Data inputs for an 18-bit bus.
Q ₀₋₁₇	Data Outputs	O	Data outputs for an 18-bit bus.
WEN	Write Enable	I	Enables the WCLK input.
REN	Read Enable	I	Enables the RCLK input.
WCLK	Write Clock	I	The rising edge clocks data into the FIFO when \overline{WEN} is LOW and the FIFO is not Full. When LD is asserted, WCLK writes data into the programmable flag-offset register.
RCLK	Read Clock	I	The rising edge clocks data out of the FIFO when \overline{REN} is LOW and the FIFO is not Empty. When LD is asserted, RCLK reads data out of the programmable flag-offset register.
$\overline{WXO}/\overline{HF}$	Write Expansion Out/Half Full Flag	O	Dual-Mode Pin. Single device or width expansion - Half Full status flag. Cascaded – Write Expansion Out signal, connected to WXI of next device.
\overline{EF}	Empty Flag	O	When \overline{EF} is LOW, the FIFO is empty. \overline{EF} is synchronized to RCLK.
\overline{FF}	Full Flag	O	When \overline{FF} is LOW, the FIFO is full. \overline{FF} is synchronized to WCLK.
\overline{PAE}	Programmable Almost Empty	O	When \overline{PAE} is LOW, the FIFO is almost empty based on the almost empty offset value programmed into the FIFO. PAE is asynchronous when V _{CC} /SMODE is tied to V _{CC} ; it is synchronized to RCLK when V _{CC} /SMODE is tied to V _{SS} .
\overline{PAF}	Programmable Almost Full	O	When \overline{PAF} is LOW, the FIFO is almost full based on the almost full offset value programmed into the FIFO. PAF is asynchronous when V _{CC} /SMODE is tied to V _{CC} ; it is synchronized to WCLK when V _{CC} /SMODE is tied to V _{SS} .
\overline{LD}	Load	I	When \overline{LD} is LOW, D ₀₋₁₇ (O ₀₋₁₇) are written (read) into (from) the programmable-flag-offset register.
$\overline{FL}/\overline{RT}$	First Load/Retransmit	I	Dual-Mode Pin. Cascaded – The first device in the daisy chain will have \overline{FL} tied to V _{SS} ; all other devices will have FL tied to V _{CC} . In standard mode of width expansion, FL is tied to V _{SS} on all devices. Not Cascaded – Tied to V _{SS} . Retransmit function is also available in standalone mode by strobing RT.
WXI	Write Expansion Input	I	Cascaded – Connected to \overline{WXO} of previous device. Not Cascaded – Tied to V _{SS} .
RXI	Read Expansion Input	I	Cascaded – Connected to \overline{RXO} of previous device. Not Cascaded – Tied to V _{SS} .

Pin Definitions (continued)

Signal Name	Description	IO	Function
RXO	Read Expansion Output	O	Cascaded – Connected to RXI of next device.
\overline{RS}	Reset	I	Resets device to empty condition. A reset is required before an initial read or write operation after power-up.
\overline{OE}	Output Enable	I	When \overline{OE} is LOW, the FIFO's data outputs drive the bus to which they are connected. If \overline{OE} is HIGH, the FIFO's outputs are in High Z (high-impedance) state.
V_{CC}/\overline{SMODE}	Synchronous Almost Empty/Almost Full Flags	I	Dual-Mode Pin. Asynchronous Almost Empty/Almost Full flags – tied to V_{CC} . Synchronous Almost Empty/Almost Full flags – tied to V_{SS} . (Almost Empty synchronized to RCLK, Almost Full synchronized to WCLK.)

Architecture

The CY7C42X5 consists of an array of 64 to 4K words of 18 bits each (implemented by a dual-port array of SRAM cells), a read pointer, a write pointer, control signals (RCLK, WCLK, REN, WEN, RS), and flags (\overline{EF} , PAE, \overline{HF} , PAF, FF). The CY7C42X5 also includes the control signals WXI, RXI, WXO, RXO for depth expansion.

Resetting the FIFO

Upon power-up, the FIFO must be reset with a Reset (\overline{RS}) cycle. This causes the FIFO to enter the Empty condition signified by \overline{EF} being LOW. All data outputs go LOW after the falling edge of \overline{RS} only if \overline{OE} is asserted. In order for the FIFO to reset to its default state, a falling edge must occur on RS and the user must not read or write while RS is LOW.

FIFO Operation

When the \overline{WEN} signal is active (LOW), data present on the D_{0-17} pins is written into the FIFO on each rising edge of the WCLK signal. Similarly, when the \overline{REN} signal is active LOW, data in the FIFO memory will be presented on the Q_{0-17} outputs. New data will be presented on each rising edge of RCLK while REN is active LOW and \overline{OE} is LOW. \overline{REN} must set up t_{ENS} before RCLK for it to be a valid read function. \overline{WEN} must occur t_{ENS} before WCLK for it to be a valid write function.

An Output Enable (\overline{OE}) pin is provided to three-state the Q_{0-17} outputs when \overline{OE} is deasserted. When \overline{OE} is enabled (LOW), data in the output register will be available to the Q_{0-17} outputs after t_{OE} . If devices are cascaded, the OE function will only output data on the FIFO that is read enabled.





The FIFO contains overflow circuitry to disallow additional writes when the FIFO is full, and underflow circuitry to disallow additional reads when the FIFO is empty. An empty FIFO maintains the data of the last valid read on its Q_{0-17} outputs even after additional reads occur.

Programming

The CY7C42X5 devices contain two 12-bit offset registers. Data present on D_{0-11} during a program write will determine the distance from Empty (Full) that the Almost Empty (Almost Full) flags become active. If the user elects not to program the FIFO's flags, the default offset values are used (see Table 2). When the Load LD pin is set LOW and WEN is set LOW, data on the inputs D_{0-11} is written into the Empty offset register on the first LOW-to-HIGH transition of the write clock (WCLK). When the LD pin and WEN are held LOW then data is written into the Full offset register on the second LOW-to-HIGH transition of the Write Clock (WCLK). The third transition of the Write Clock (WCLK) again writes to the Empty offset register (see Table 1). Writing all offset registers does not have to occur at one time. One or two offset registers can be written and then, by bringing the LD pin HIGH, the FIFO is returned to normal read/write operation. When the LD pin is set LOW, and WEN is LOW, the next offset register in sequence is written.

The contents of the offset registers can be read on the output lines when the LD pin is set LOW and REN is set LOW; then, data can be read on the LOW-to-HIGH transition of the Read Clock (RCLK).

Table 1. Write Offset Register

LD	WEN	WCLK ^[1]	Selection
0	0		Writing to offset registers: Empty Offset  Full Offset
0	1		No Operation
1	0		Write Into FIFO
1	1		No Operation

Note:

1. The same selection sequence applies to reading from the registers. \overline{REN} is enabled and read is performed on the LOW-to-HIGH transition of RCLK.

Flag Operation

The CY7C42X5 devices provide five flag pins to indicate the condition of the FIFO contents. Empty and Full are synchronous. PAE and PAF are synchronous if $V_{CC}/SMODE$ is tied to V_{SS} .

Full Flag

The Full Flag (\overline{FF}) will go LOW when device is Full. Write operations are inhibited whenever FF is LOW regardless of the state of WEN. FF is synchronized to WCLK, i.e., it is exclusively updated by each rising edge of WCLK.

Empty Flag

The Empty Flag (\overline{EF}) will go LOW when the device is empty. Read operations are inhibited whenever EF is LOW, regardless of the state of REN. EF is synchronized to RCLK, i.e., it is exclusively updated by each rising edge of RCLK.

Programmable Almost Empty/Almost Full Flag

The CY7C42X5 features programmable Almost Empty and Almost Full Flags. Each flag can be programmed (described in the Programming section) a specific distance from the corresponding boundary flags (Empty or Full). When the FIFO contains the number of words or fewer for which the flags have been programmed, the PAF or PAE will be asserted, signifying

that the FIFO is either Almost Full or Almost Empty. See [Table 2](#) for a description of programmable flags.

When the \overline{SMODE} pin is tied LOW, the \overline{PAF} flag signal transition is caused by the rising edge of the write clock and the PAE flag transition is caused by the rising edge of the read clock.

Retransmit

The retransmit feature is beneficial when transferring packets of data. It enables the receipt of data to be acknowledged by the receiver and retransmitted if necessary.

The Retransmit (RT) input is active in the standalone and width expansion modes. The retransmit feature is intended for use when a number of writes equal to or less than the depth of the FIFO have occurred since the last RS cycle. A HIGH pulse on RT resets the internal read pointer to the first physical location of the FIFO. WCLK and RCLK may be free running but must be disabled during and tRTR after the retransmit pulse. With every valid read cycle after retransmit, previously accessed data is read and the read pointer is incremented until it is equal to the write pointer. Flags are governed by the relative locations of the read and write pointers and are updated during a retransmit cycle. Data written to the FIFO after activation of RT are transmitted also.

The full depth of the FIFO can be repeatedly retransmitted.

Table 2. Flag Truth Table

Number of Words in FIFO			\overline{FF}	\overline{PAF}	\overline{HF}	\overline{PAE}	\overline{EF}
CY7C4425 - 64 x 18	CY7C4205 - 256 x 18	CY7C4215 - 512 x 18					
0	0	0	H	H	H	L	L
1 to $n^{[2]}$	1 to $n^{[2]}$	1 to $n^{[2]}$	H	H	H	L	H
$(n + 1)$ to 32	$(n + 1)$ to 128	$(n + 1)$ to 256	H	H	H	H	H
33 to $(64 - (m + 1))$	129 to $(256 - (m + 1))$	257 to $(512 - (m + 1))$	H	H	L	H	H
$(64 - m)^{[1]}$ to 63	$(256 - m)^{[1]}$ to 255	$(512 - m)^{[1]}$ to 511	H	L	L	H	H
64	256	512	L	L	L	H	H

Number of Words in FIFO			\overline{FF}	\overline{PAF}	\overline{HF}	\overline{PAE}	\overline{EF}
CY7C4225 - 1K x 18	CY7C4235 - 2K x 18	CY7C4245 - 4K x 18					
0	0	0	H	H	H	L	L
1 to $n^{[2]}$	1 to $n^{[2]}$	1 to $n^{[2]}$	H	H	H	L	H
$(n + 1)$ to 512	$(n + 1)$ to 1024	$(n + 1)$ to 2048	H	H	H	H	H
513 to $(1024 - (m + 1))$	1025 to $(2048 - (m + 1))$	2049 to $(4096 - (m + 1))$	H	H	L	H	H
$(1024 - m)^{[3]}$ to 1023	$(2048 - m)^{[3]}$ to 2047	$(4096 - m)^{[3]}$ to 4095	H	L	L	H	H
1024	2048	4096	L	L	L	H	H

Note

- n = Empty Offset (Default Values: CY7C4425 $n = 7$, CY7C4205 $n = 31$, CY7C4215 $n = 63$, CY7C4225/CY7C4235/CY7C4245 $n = 127$).
- m = Full Offset (Default Values: CY7C4425 $m = 7$, CY7C4205 $m = 31$, CY7C4215 $m = 63$, CY7C4225/CY7C4235/CY7C4245 $m = 127$).

Width Expansion Configuration

The CY7C42X5 can be expanded in width to provide word widths greater than 18 in increments of 18. During width expansion mode all control line inputs are common and all flags are

available. Empty (Full) flags should be created by ANDing the Empty (Full) flags of every FIFO. This technique will avoid ready data from the FIFO that is "staggered" by one clock cycle due to the variations in skew between RCLK and WCLK. Figure 3 demonstrates a 36-word width by using two CY7C42X5.

Figure 3. Block Diagram of Synchronous FIFO Memories Used in a Width Expansion Configuration

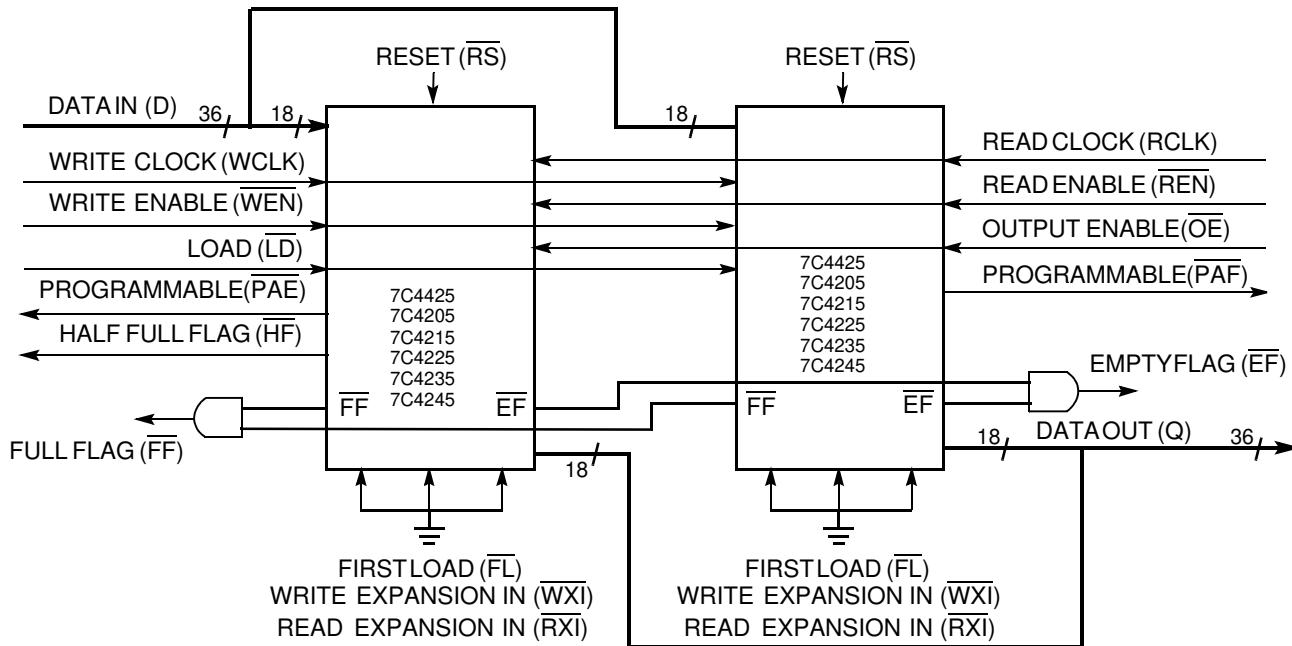

Depth Expansion Configuration (with Programmable Flags)

The CY7C42X5 can easily be adapted to applications requiring more than 64/256/512/1024/2048/4096 words of buffering. Figure 4 shows Depth Expansion using three CY7C42X5s. Maximum depth is limited only by signal loading. Follow these steps:

1. The first device must be designated by grounding the First Load (FL) control input.
2. All other devices must have \overline{FL} in the HIGH state.
3. The Write Expansion Out (\overline{WXO}) pin of each device must be tied to the Write Expansion In (WXI) pin of the next device.
4. The Read Expansion Out (\overline{RXO}) pin of each device must be tied to the Read Expansion In (RXI) pin of the next device.
5. All Load (\overline{LD}) pins are tied together.
6. The Half-Full Flag (\overline{HF}) is not available in the Depth Expansion Configuration.
7. \overline{EF} , \overline{FF} , \overline{PAE} , and \overline{PAF} are created with composite flags by ORing together these respective flags for monitoring. The composite \overline{PAE} and \overline{PAF} flags are not precise.

Figure 4. Block Diagram of Synchronous FIFO Memory with Programmable Flags used in Depth Expansion Configuration

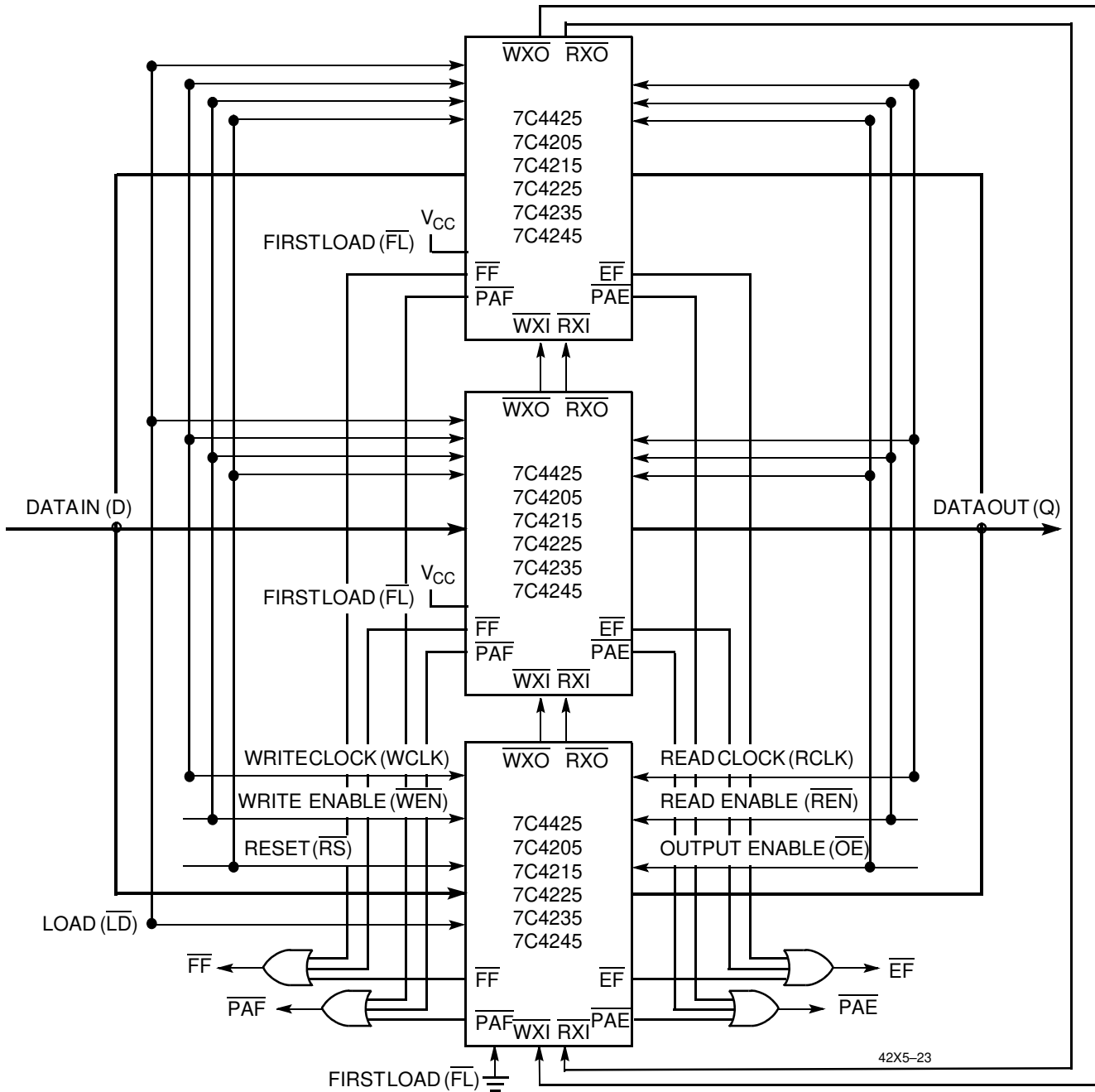

42X5-23

Maximum Ratings^[6]

(Above which the useful life may be impaired. For user guidelines, not tested.)

- Storage Temperature-65°C to +150°C
- Ambient Temperature with Power Applied.....-55°C to +125°C
- Supply Voltage to Ground Potential-0.5V to +7.0V
- DC Voltage Applied to Outputs in High-Z State-0.5V to +7.0V

- DC Input Voltage-3.0V to +7.0V
- Output Current into Outputs (LOW)..... 20 mA
- Static Discharge Voltage >2001V (per MIL-STD-883, Method 3015)
- Latch-up Current >200 mA

Operating Range

Range	Ambient Temperature	V _{CC}
Commercial	0°C to +70°C	5V ± 10%
Industrial ^[4]	-40°C to +85°C	5V ± 10%

Electrical Characteristics Over the Operating Range^[6]

Parameter	Description	Test Conditions	-10		-15		-25		-35		Unit
			Min.	Max.	Min.	Max.	Min.	Max.	Min.	Max.	
V _{OH}	Output HIGH Voltage	V _{CC} = Min., I _{OH} = -2.0 mA	2.4		2.4		2.4		2.4		V
V _{OL}	Output LOW Voltage	V _{CC} = Min., I _{OL} = 8.0 mA		0.4		0.4		0.4		0.4	V
V _{IH} ^[7]	Input HIGH Voltage		2.2	V _{CC}	2.2	V _{CC}	2.2	V _{CC}	2.2	V _{CC}	V
V _{IL} ^[7]	Input LOW Voltage		-3.0	0.8	-3.0	0.8	-3.0	0.8	-3.0	0.8	V
I _{IX}	Input Leakage Current	V _{CC} = Max.	-10	+10	-10	+10	-10	+10	-10	+10	µA
I _{OS} ^[8]	Output Short Circuit Current	V _{CC} = Max., V _{OUT} = GND	-90		-90		-90		-90		µA
I _{OZL} I _{OZH}	Output OFF, High Z Current	$\overline{OE} \geq V_{IH}$, V _{SS} < V _O < V _{CC}	-10	+10	-10	+10	-10	+10	-10	+10	µA
I _{CC} ^[9]	Operating Current	V _{CC} = Max., I _{OUT} = 0 mA	Com'l	45	45	45	45	45	45	45	mA
			Ind'l	50	50	50	50	50	50	50	mA
I _{SB} ^[10]	Standby Current	V _{CC} = Max., I _{OUT} = 0 mA	Com'l	10	10	10	10	10	10	10	mA
			Ind'l	15	15	15	15	15	15	15	mA

Capacitance^[11]

Parameter	Description	Test Conditions	Max.	Unit
C _{IN}	Input Capacitance	T _A = 25°C, f = 1 MHz, V _{CC} = 5.0V	5	pF
C _{OUT}	Output Capacitance		7	pF

Notes

4. T_A is the "instant on" case temperature.
5. See the last page of this specification for Group A subgroup testing information.
6. The Voltage on any input or I/O pin cannot exceed the power pin during power-up
7. The V_{IH} and V_{IL} specifications apply for all inputs except WXI, RXI. The WXI, RXI pin is not a TTL input. It is connected to either \overline{RXO} , \overline{WXO} of the previous device or V_{SS}.
8. Test no more than one output at a time for not more than one second.
9. Input signals switch from 0V to 3V with a rise/fall time less than 3 ns, clocks and clock enables switch at 20 MHz, while the data inputs switch at 10 MHz. Outputs are unloaded.
10. All input signals are connected to V_{CC}. All outputs are unloaded.
11. Tested initially and after any design or process changes that may affect these parameters.

Figure 5. AC Test Loads and Waveforms^[13, 14]

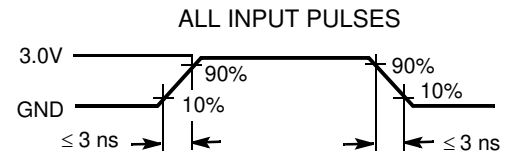
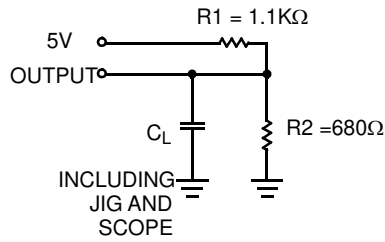

Equivalent to: THÉVENIN EQUIVALENT
 $R_{th} = 410\Omega$
 $V_{th} = 1.91V$

Switching Characteristics Over the Operating Range

Parameter	Description	-10		-15		-25		-35		Unit
		Min.	Max.	Min.	Max.	Min.	Max.	Min.	Max.	
t_S	Clock Cycle Frequency		100		66.7		40		28.6	MHz
t_A	Data Access Time	2	8	2	10	2	15	2	20	ns
t_{CLK}	Clock Cycle Time	10		15		25		35		ns
t_{CLKH}	Clock HIGH Time	4.5		6		10		14		ns
t_{CLKL}	Clock LOW Time.	4.5		6		10		14		ns
t_{DS}	Data Set-up Time	3		4		6		7		ns
t_{DH}	Data Hold Time	0.5		1		1		2		ns
t_{ENS}	Enable Set-up Time	3		4		6		7		ns
t_{ENH}	Enable Hold Time	0.5		1		1		2		ns
t_{RS}	Reset Pulse Width ^[15]	10		15		25		35		ns
t_{RSR}	Reset Recovery Time	8		10		15		20		ns
t_{RSF}	Reset to Flag and Output Time		10		15		25		35	ns
t_{PRT}	Retransmit Pulse Width	12		15		25		35		ns
t_{RTR}	Retransmit Recovery Time	12		15		25		35		ns
t_{OLZ}	Output Enable to Output in Low Z ^[16]	0		0		0		0		ns
t_{OE}	Output Enable to Output Valid	3	7	3	8	3	12	3	15	ns
t_{OHZ}	Output Enable to Output in High Z ^[16]	3	7	3	8	3	12	3	15	ns
t_{WFF}	Write Clock to Full Flag		8		10		15		20	ns
t_{REF}	Read Clock to Empty Flag		8		10		15		20	ns
$t_{PAFasynch}$	Clock to Programmable Almost-Full Flag ^[17] (Asynchronous mode, $V_{CC}/SMODE$ tied to V_{CC})		12		16		20		25	ns
$t_{PAFsynch}$	Clock to Programmable Almost-Full Flag (Synchronous mode, $V_{CC}/SMODE$ tied to V_{SS})		8		10		15		20	ns
$t_{PAEasynch}$	Clock to Programmable Almost-Empty Flag ^[17] (Asynchronous mode, $V_{CC}/SMODE$ tied to V_{CC})		12		16		20		25	ns
$t_{PAEsynch}$	Clock to Programmable Almost-Empty Flag (Synchronous mode, $V_{CC}/SMODE$ tied to V_{SS})		8		10		15		20	ns

Notes

- 13. $C_L = 30$ pF for all AC parameters except for t_{OHZ} .
- 14. $C_L = 5$ pF for t_{OHZ} .
- 15. Pulse widths less than minimum values are not allowed.
- 16. Values guaranteed by design, not currently tested.
- 17. $t_{PAFasynch}$, $t_{PAEsynch}$ after program register write will not be valid until 5 ns + $t_{PAF(E)}$.

Switching Characteristics Over the Operating Range (continued)

Parameter	Description	-10		-15		-25		-35		Unit
		Min.	Max.	Min.	Max.	Min.	Max.	Min.	Max.	
t_{HF}	Clock to Half-Full Flag		12		16		20		25	ns
t_{XO}	Clock to Expansion Out		7		10		15		20	ns
t_{XI}	Expansion in Pulse Width	3		6.5		10		14		ns
t_{XIS}	Expansion in Set-up Time	4.5		5		10		15		ns
t_{SKEW1}	Skew Time between Read Clock and Write Clock for Full Flag	5		6		10		12		ns
t_{SKEW2}	Skew Time between Read Clock and Write Clock for Empty Flag	5		6		10		12		ns
t_{SKEW3}	Skew Time between Read Clock and Write Clock for Programmable Almost Empty and Programmable Almost Full Flags.	10		15		18		20		ns

Switching Waveforms

Figure 6. Write Cycle Timing

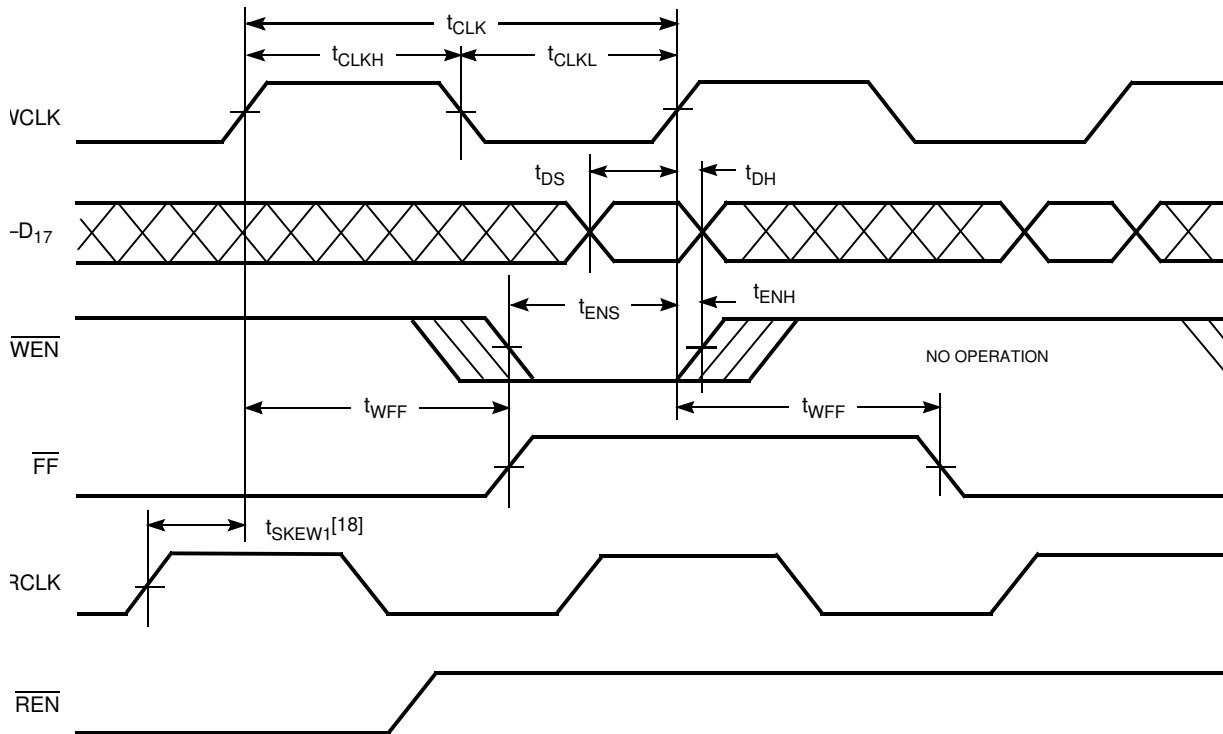

Note

18. t_{SKEW1} is the minimum time between a rising RCLK edge to a rising WCLK edge to guarantee that \overline{FF} will go HIGH during the current clock cycle. If the time between the rising edge of RCLK and the rising edge of WCLK is less than t_{SKEW1} , then FF may not change state until the next WCLK edge.

Switching Waveforms (continued)

Figure 7. Read Cycle Timing

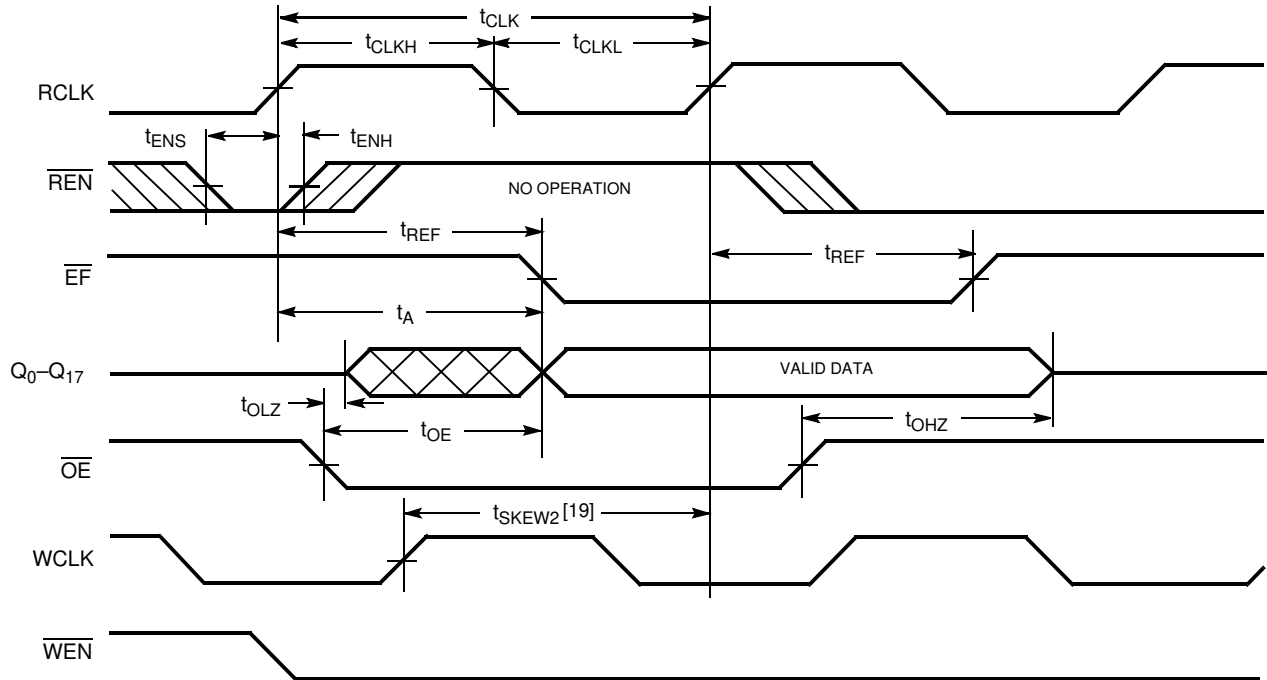
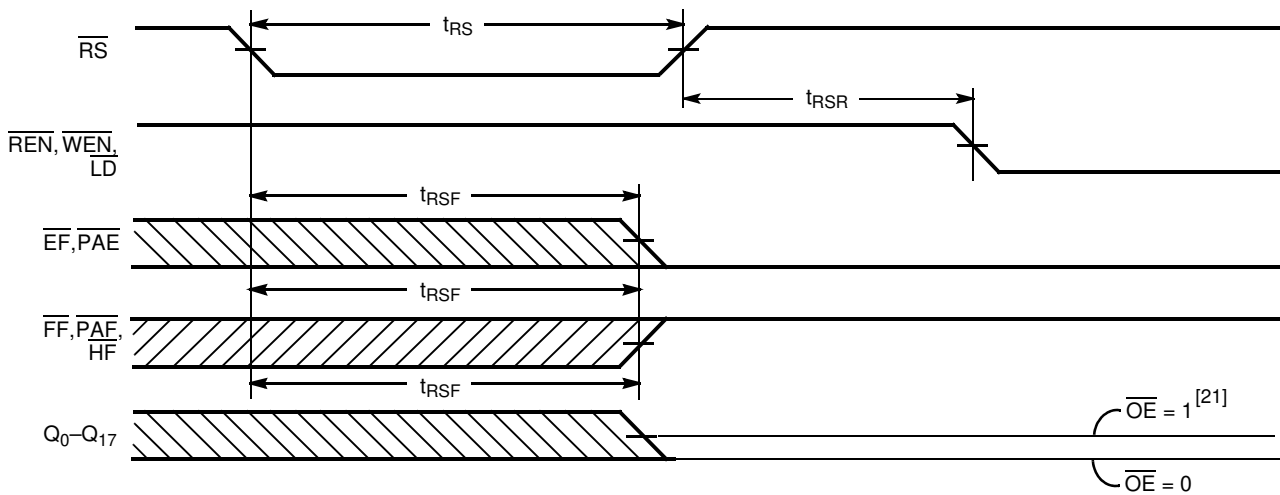

Figure 8. Reset Timing^[20]



Notes:

19. t_{SKEW2} is the minimum time between a rising WCLK edge and a rising RCLK edge to guarantee that \overline{EF} will go HIGH during the current clock cycle. If the time between the rising edge of WCLK and the rising edge of RCLK is less than t_{SKEW2} , then \overline{EF} may not change state until the next RCLK edge.
20. The clocks (RCLK, WCLK) can be free-running during reset.
21. After reset, the outputs will be LOW if $\overline{OE} = 0$ and three-state if $\overline{OE} = 1$.

Switching Waveforms (continued)

Figure 9. First Data Word Latency after Reset with Simultaneous Read and Write

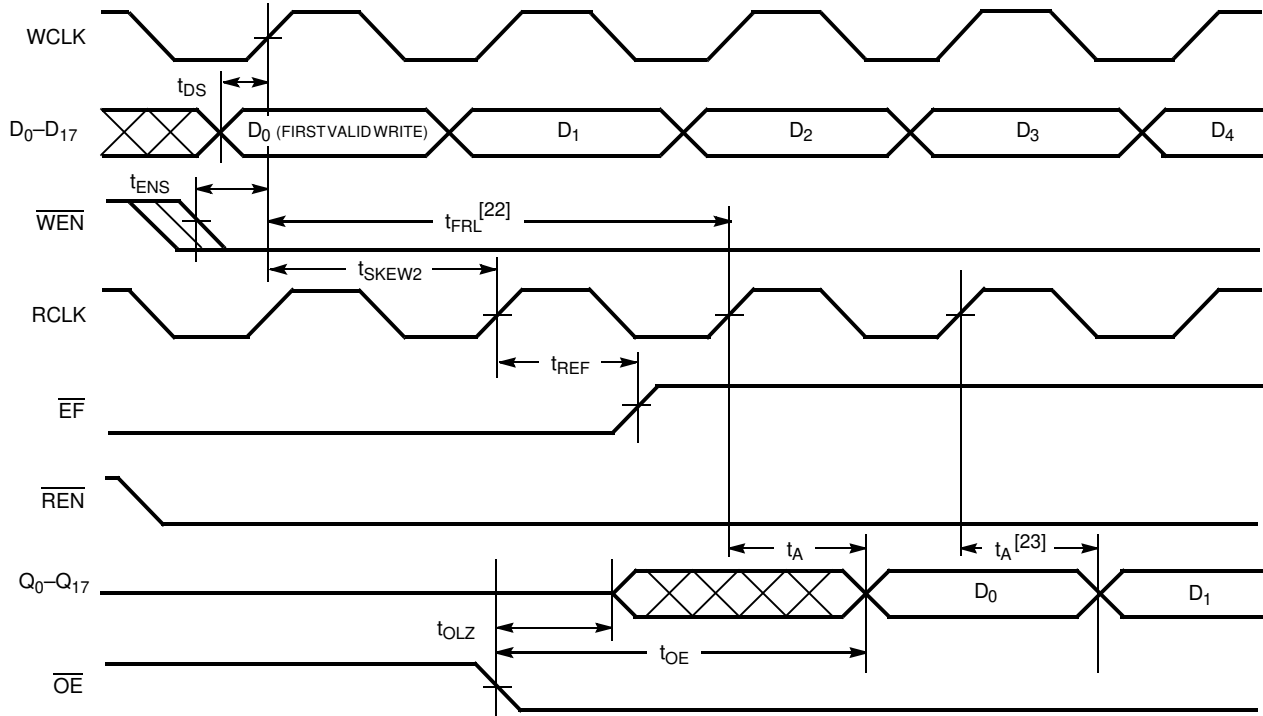
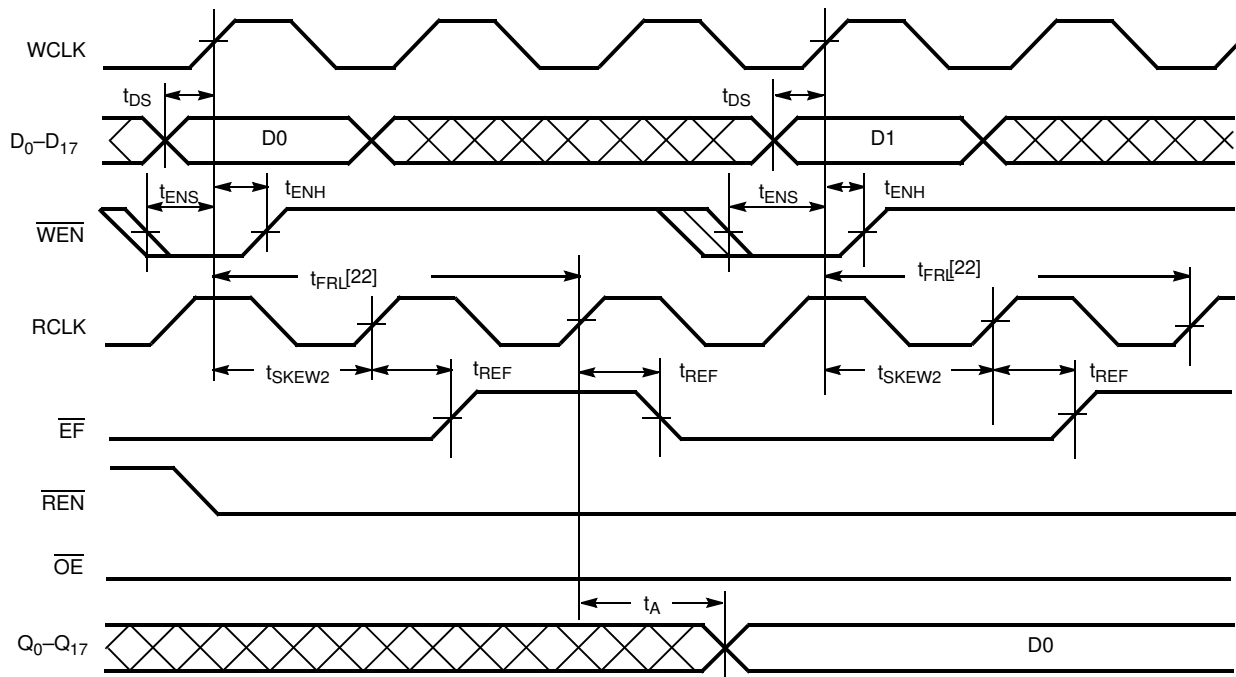

Figure 10. Empty Flag Timing



Notes:

- 22. When $t_{SKEW2} \geq$ minimum specification, t_{FRL} (maximum) = $t_{CLK} + t_{SKEW2}$. When $t_{SKEW2} <$ minimum specification, t_{FRL} (maximum) = either $2 * t_{CLK} + t_{SKEW2}$ or $t_{CLK} + t_{SKEW2}$. The Latency Timing applies only at the Empty Boundary (EF = LOW).
- 23. The first word is available the cycle after EF goes HIGH, always.

Switching Waveforms (continued)

Figure 11. Full Flag Timing

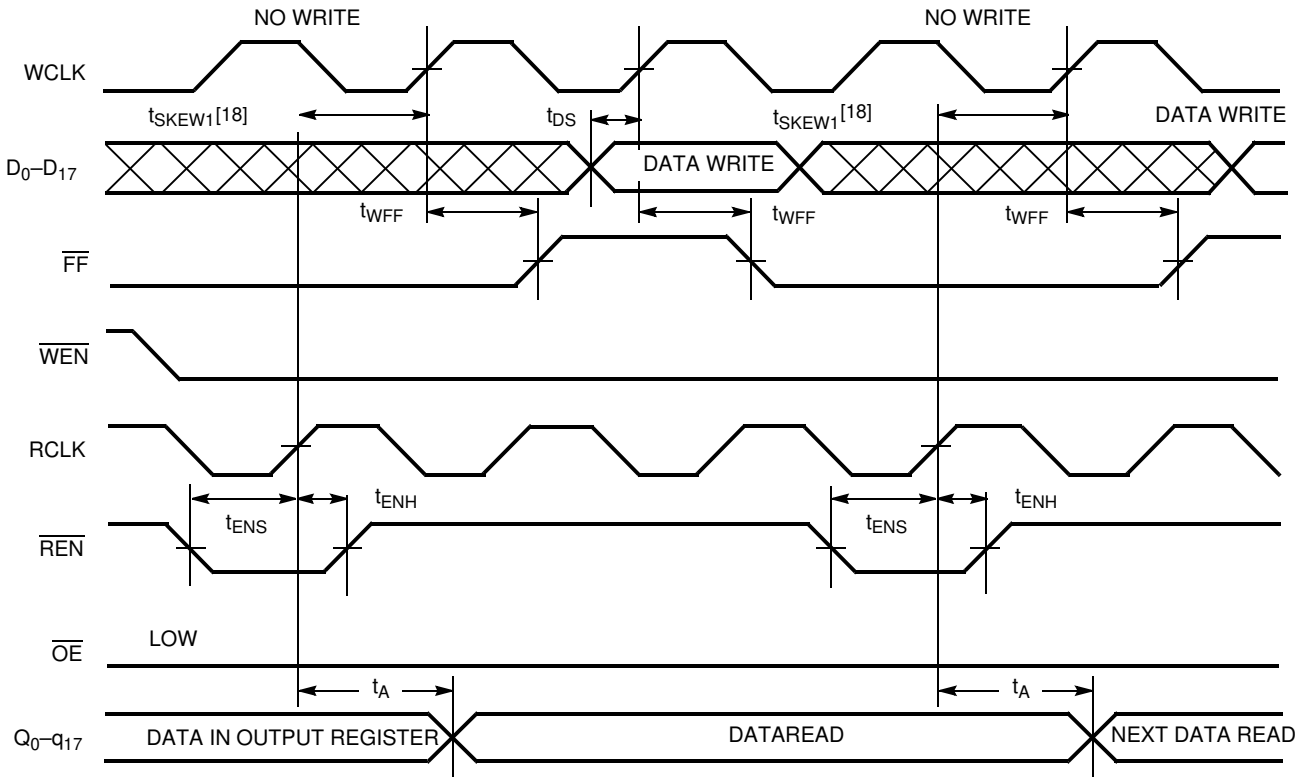
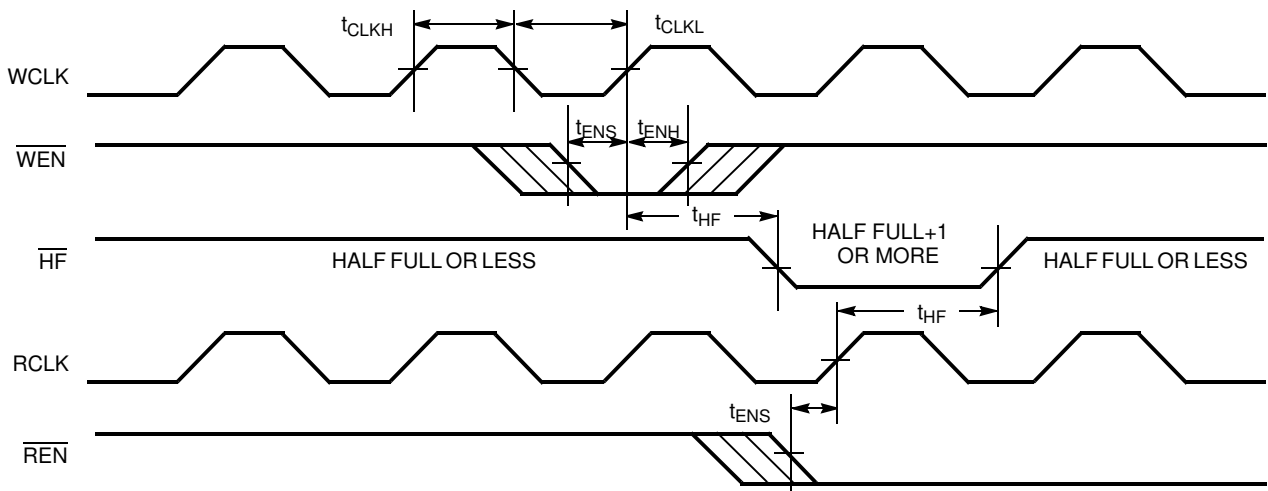

Figure 12. Half-Full Flag Timing



Switching Waveforms (continued)

Figure 13. Programmable Almost Empty Flag Timing

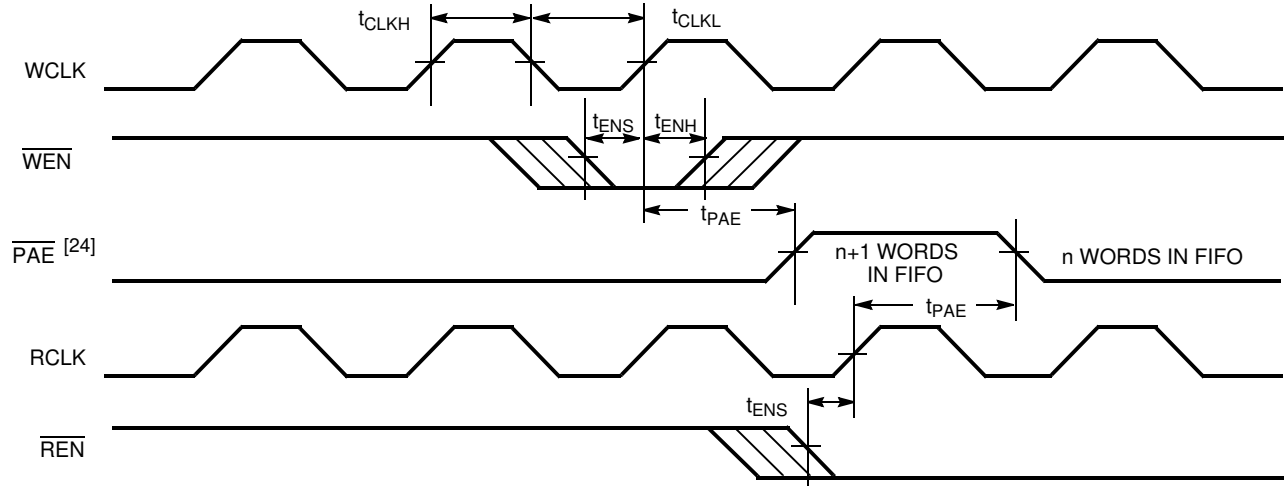
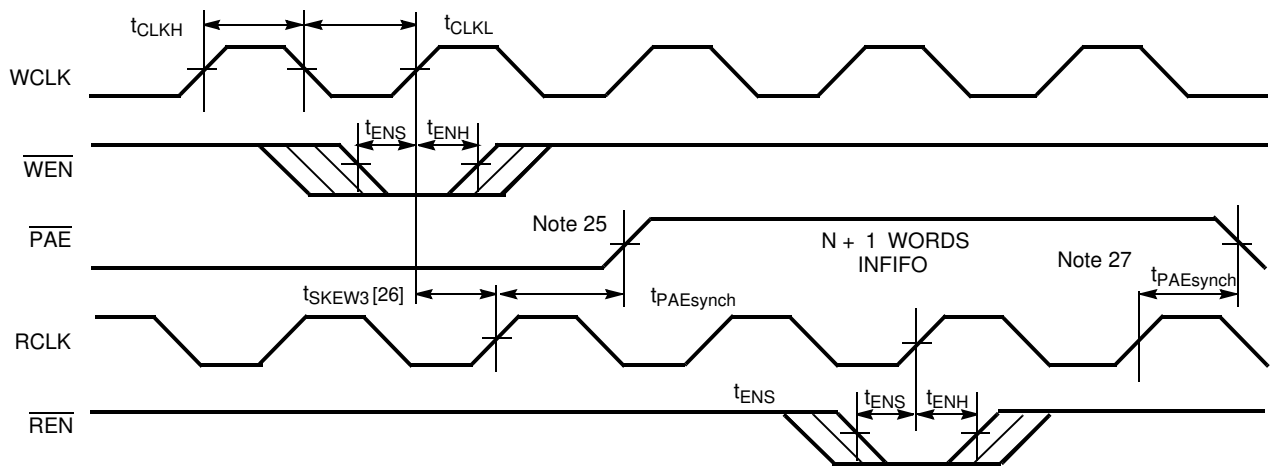

Figure 14. Programmable Almost Empty Flag Timing (applies only in \overline{SMODE} (\overline{SMODE} is LOW))



Notes:

- 24. PAE offset - n. Number of data words into FIFO already = n.
- 25. PAE offset - n.
- 26. t_{SKEW3} is the minimum time between a rising WCLK and a rising RCLK edge for PAE to change state during that clock cycle. If the time between the edge of WCLK and the rising RCLK is less than t_{SKEW3} , then PAE may not change state until the next RCLK.
- 27. If a read is performed on this rising edge of the read clock, there will be Empty + (n-1) words in the FIFO when PAE goes LOW.

Switching Waveforms (continued)

Figure 15. Programmable Almost Full Flag Timing

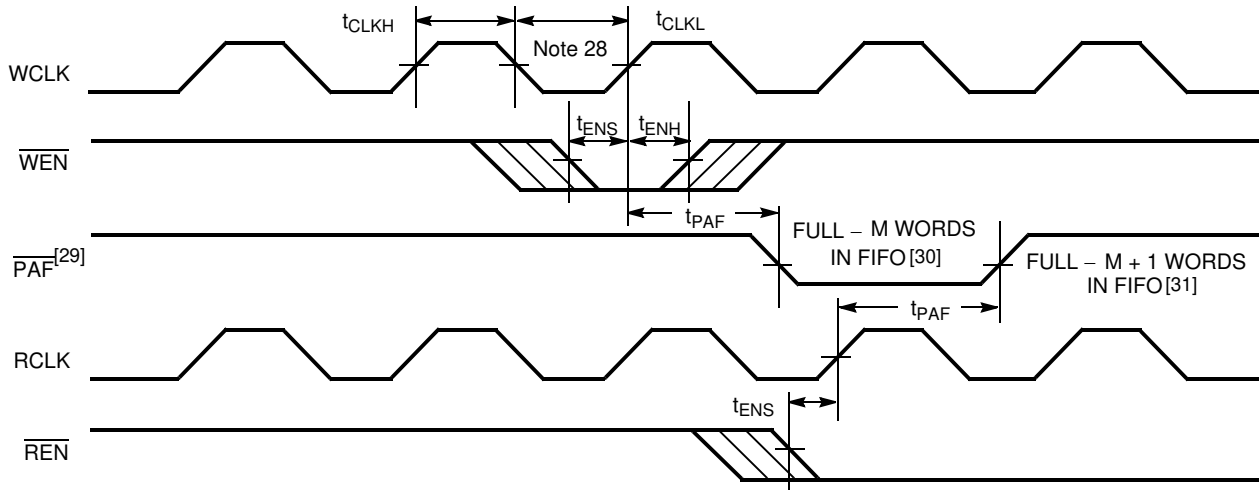
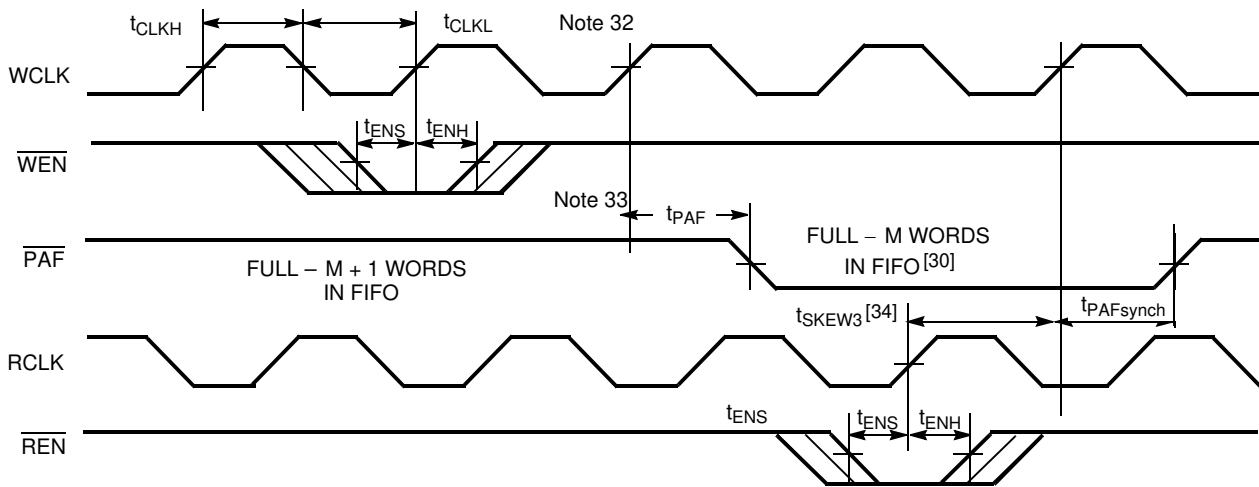

Figure 16. Programmable Almost Full Flag Timing (applies only in SMODE (SMODE in LOW))



Notes:

- 28. PAF offset = m. Number of data words written into FIFO already = 64 - m + 1 for the CY7C4425, 256 - m + 1 for the CY7C4205, 512 - m + 1 for the CY7C4215, 1024 - m + 1 for the CY7C4225, 2048 - m + 1 for the CY7C4235, and 4096 - m + 1 for the CY7C4245.
- 29. PAF is offset = m.
- 30. 64 - m words in CY7C4425, 256 - m words in CY7C4205, 512 - m words in CY7C4215, 1024 - m words in CY7C4225, 2048 - m words in CY7C4235, and 4096 - m words in CY7C4245.
- 31. 64 - m + 1 words in CY7C4425, 256 - m + 1 words in CY7C4205, 512 - m + 1 words in CY7C4215, 1024 - m + 1 CY7C4225, 2048 - m + 1 in CY7C4235, and 4096 - m + 1 words in CY7C4245.
- 32. If a write is performed on this rising edge of the write clock, there will be Full - (m-1) words of the FIFO when PAF goes LOW.
- 33. PAF offset = m.
- 34. t_{SKEW3} is the minimum time between a rising RCLK and a rising WCLK edge for PAF to change state during that clock cycle. If the time between the edge of RCLK and the rising edge of WCLK is less than t_{SKEW3} , then PAF may not change state until the next WCLK rising edge.

Switching Waveforms (continued)

Figure 17. Write Programmable Registers

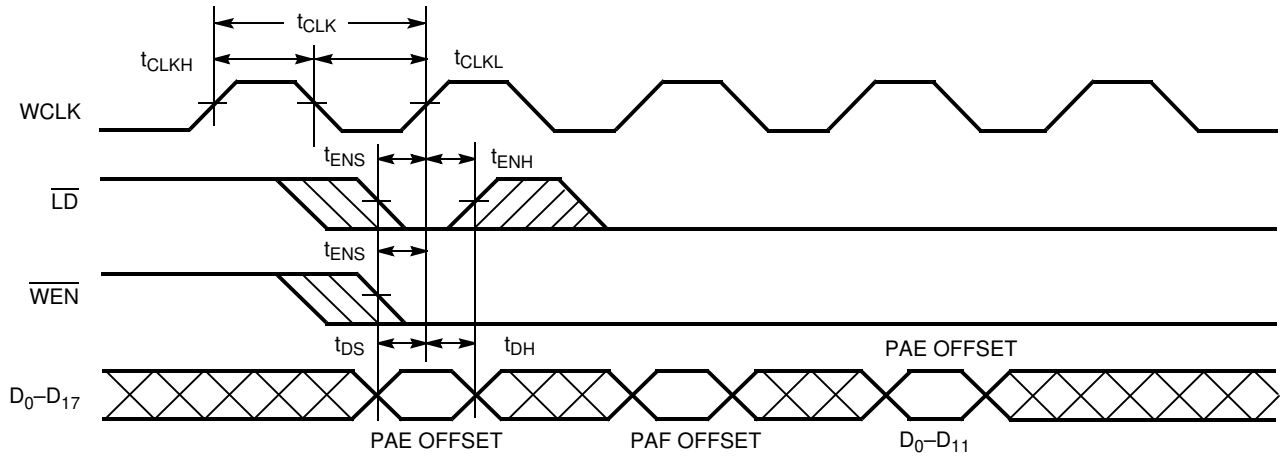

Figure 18. Read Programmable Registers

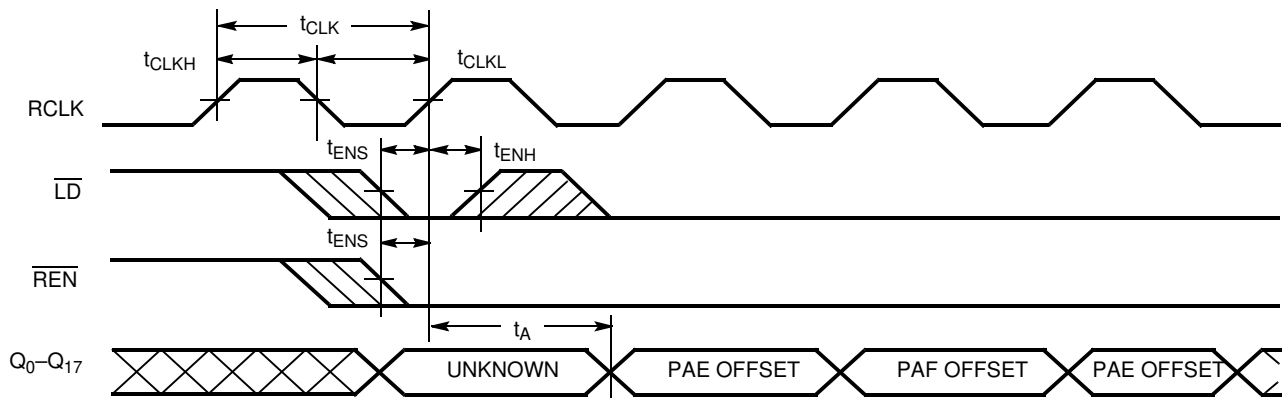
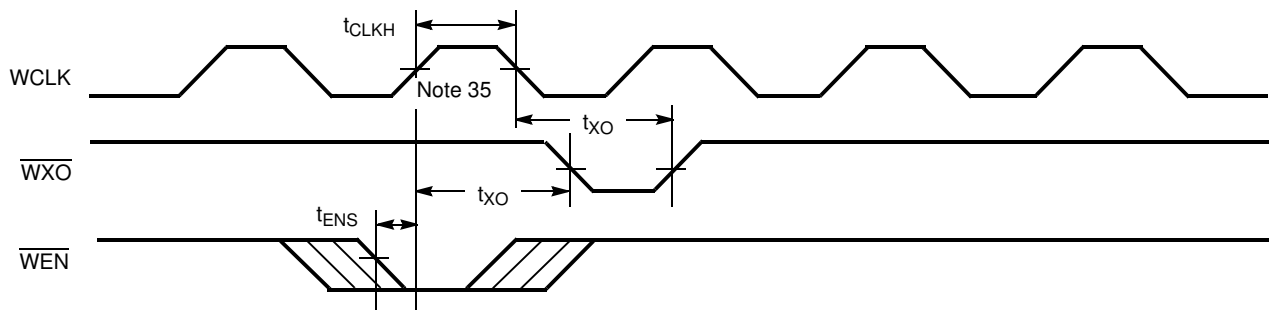

Figure 19. Write Expansion Out Timing



Note:
35. Write to Last Physical Location.

Switching Waveforms (continued)

Figure 20. Read Expansion Out Timing

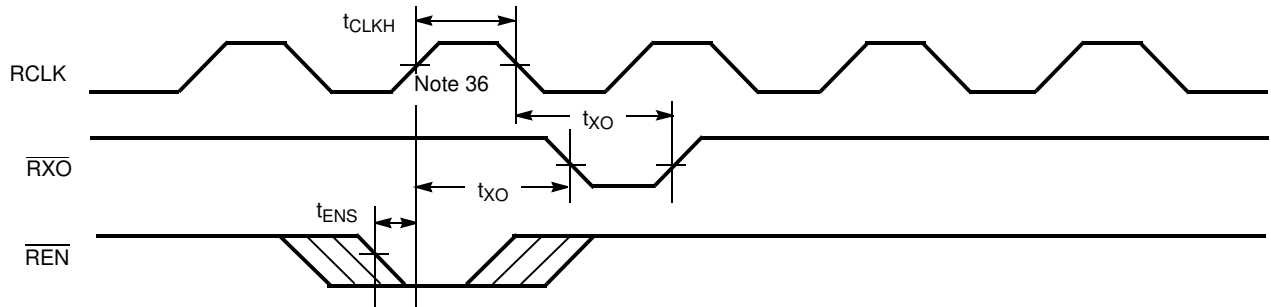

Figure 21. Write Expansion In Timing

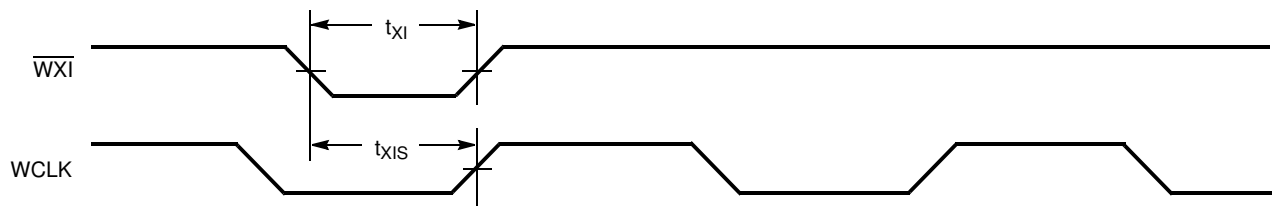

Figure 22. Read Expansion In Timing

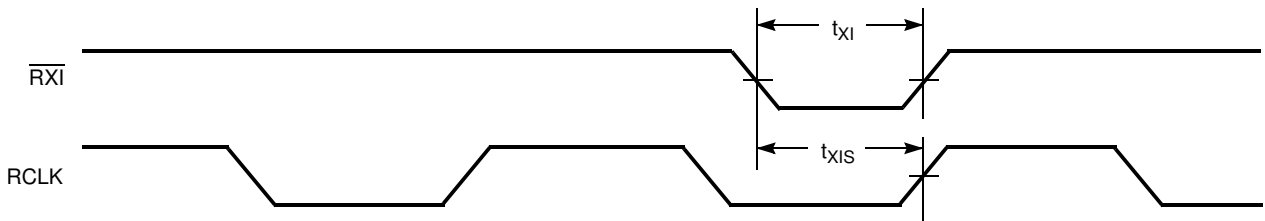
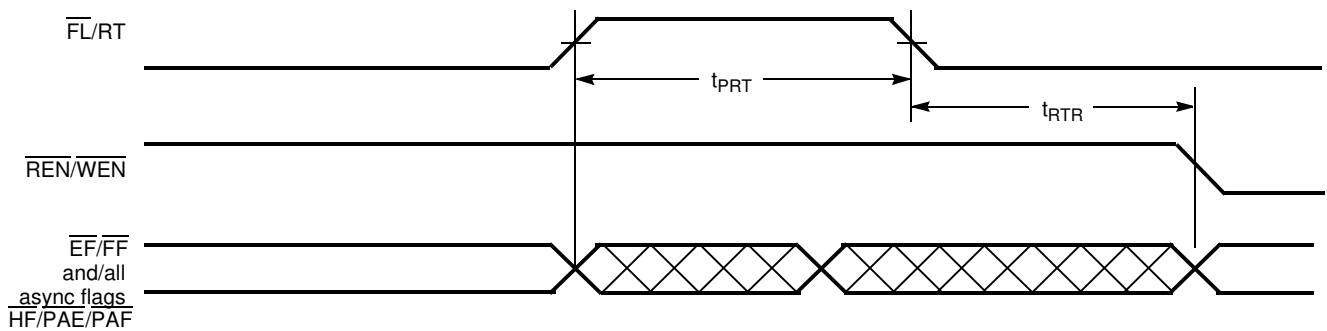

Figure 23. Retransmit Timing [37, 38, 39]



Notes:

36. Read from Last Physical Location.

37. Clocks are free running in this case.

38. The flags may change state during Retransmit as a result of the offset of the read and write pointers, but flags will be valid at t_{RTR} .

39. For the synchronous PAE and PAF flags (SMODE), an appropriate clock cycle is necessary after t_{RTR} to update these flags.

Figure 24. Typical AC and DC Characteristics

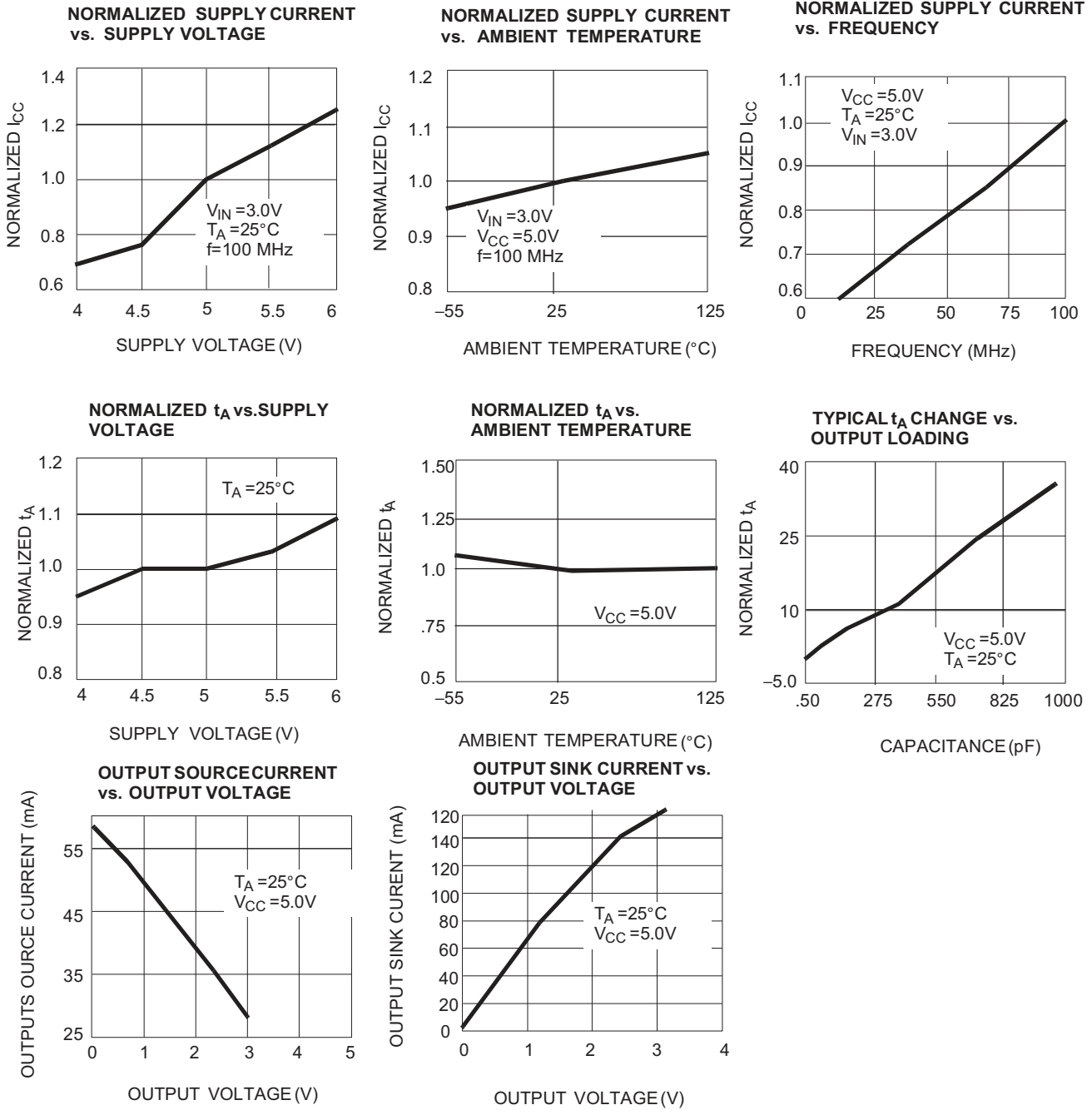

Ordering Information

256 x 18 Synchronous FIFO

Speed (ns)	Ordering Code	Package Name	Package Type	Operating Range
10	CY7C4205-10AXC	51-85046	64-Pin (14 x 14) Thin Quad Flatpack (Pb-Free)	Commercial
15	CY7C4205-15AC	51-85046	64-Pin (14 x 14) Thin Quad Flatpack	Commercial
	CY7C4205-15AXC		64-Pin (14 x 14) Thin Quad Flatpack (Pb-Free)	

512 x 18 Synchronous FIFO

Speed (ns)	Ordering Code	Package Name	Package Type	Operating Range
15	CY7C4215-15AI	51-85046	64-Pin (14 x 14) Thin Quad Flatpack	Industrial
	CY7C4215-15AXI		64-Pin (14 x 14) Thin Quad Flatpack (Pb-Free)	

1K x 18 Synchronous FIFO

Speed (ns)	Ordering Code	Package Name	Package Type	Operating Range
10	CY7C4225-10AI	51-85046	64-Pin (14 x 14) Thin Quad Flatpack	Industrial
	CY7C4225-10AXI		64-Pin (14 x 14) Thin Quad Flatpack (Pb-Free)	
15	CY7C4225-15AXC	51-85046	64-Pin (14 x 14) Thin Quad Flatpack (Pb-Free)	Commercial
	CY7C4225-15ASC	51-85051	64-Pin (10 x 10) Thin Quad Flatpack	
	CY7C4225-15ASXC		64-Pin (10 x 10) Thin Quad Flatpack (Pb-Free)	

2K x 18 Synchronous FIFO

Speed (ns)	Ordering Code	Package Name	Package Type	Operating Range
15	CY7C4235-15AC	51-85046	64-Pin (14 x 14) Thin Quad Flatpack	Commercial
	CY7C4235-15AXC		64-Pin (14 x 14) Thin Quad Flatpack (Pb-Free)	

4K x 18 Synchronous FIFO

Speed (ns)	Ordering Code	Package Name	Package Type	Operating Range
10	CY7C4245-10AXC	51-85046	64-Pin (14 x 14) Thin Quad Flatpack (Pb-Free)	Commercial
	CY7C4245-10ASXC	51-85051	64-Pin (10 x 10) Thin Quad Flatpack (Pb-Free)	
	CY7C4245-10AI	51-85046	64-Pin (14 x 14) Thin Quad Flatpack	Industrial
	CY7C4245-10AXI		64-Pin (14 x 14) Thin Quad Flatpack (Pb-Free)	
15	CY7C4245-15AXC	51-85046	64-Pin (14 x 14) Thin Quad Flatpack (Pb-Free)	Commercial
	CY7C4245-15ASXC	51-85051	64-Pin (10 x 10) Thin Quad Flatpack (Pb-Free)	
	CY7C4245-15JXC	51-85005	68-Pin Plastic Leaded Chip Carrier (Pb-Free)	

Package Diagrams

Figure 25. 64-Pin Thin Plastic Quad Flat Pack (14 x 14 x 1.4 mm), 51-85046

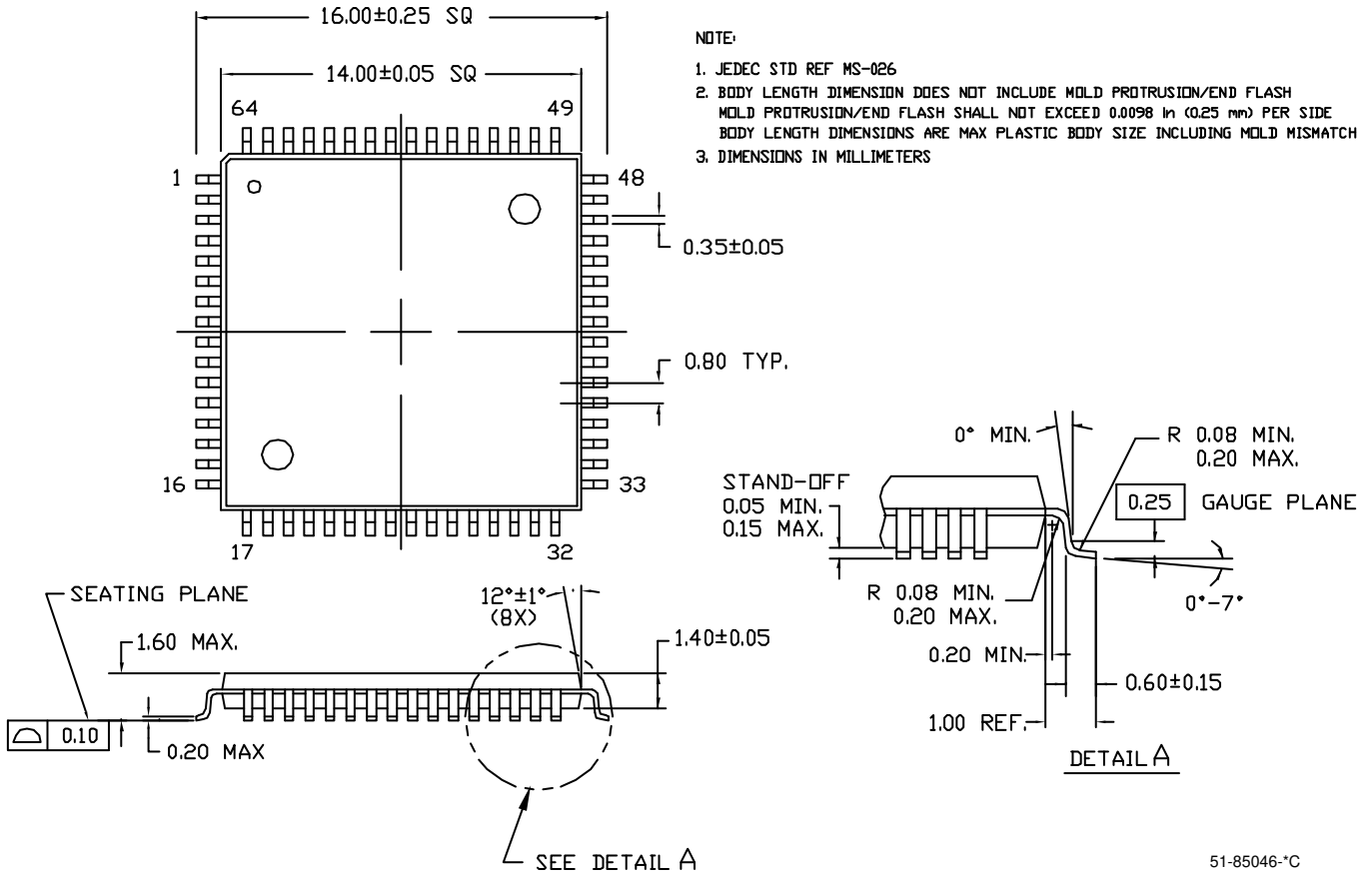

51-85046-C

Package Diagrams (continued)

Figure 26. 64-Pin Thin Plastic Quad Flat Pack (10 x 10 x 1.4 mm), 51-85051

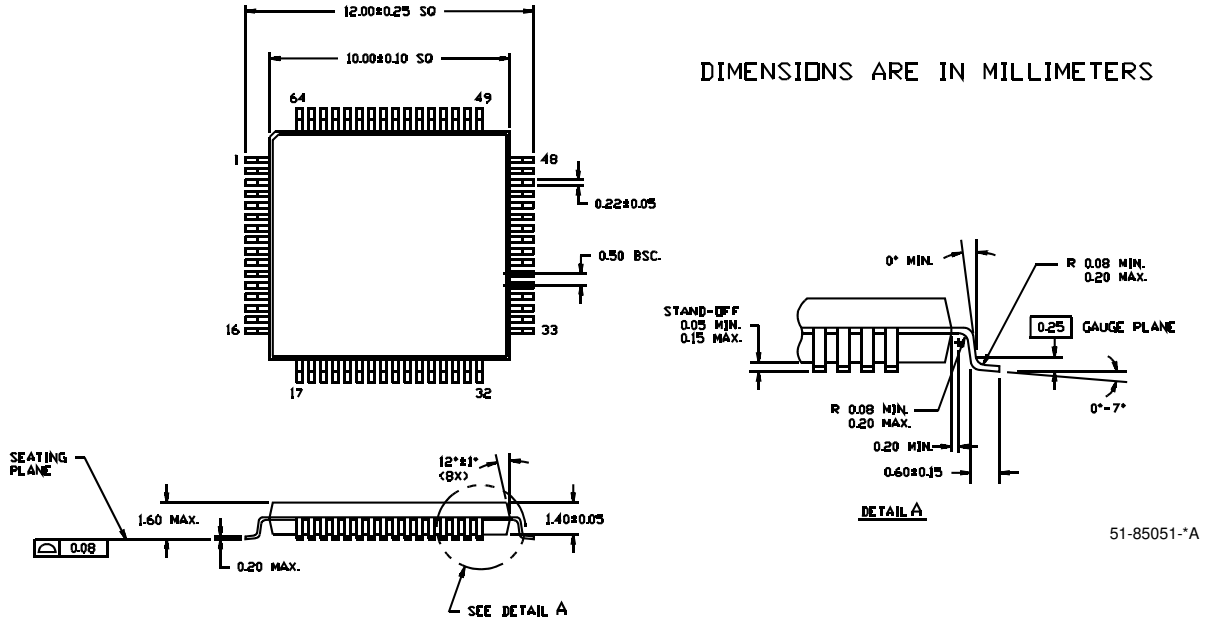
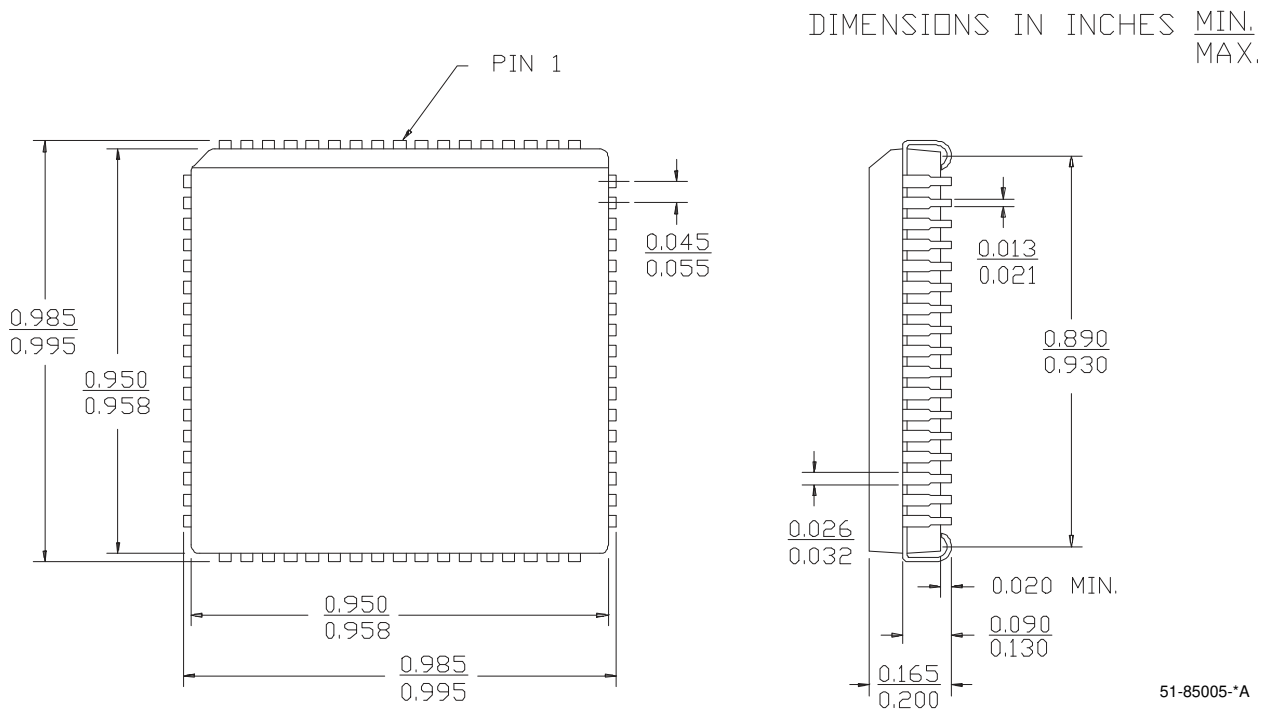

Figure 27. 68-Pin Plastic Leaded Chip Carrier, 51-85005



Document History Page

Document Title: CY7C4425/CY7C4205/CY7C4215/CY7C4225/CY7C4235/CY7C4245, 64/256/512/1K/2K/4K x 18 Synchronous FIFOs Document Number: 001-45652				
REV.	ECN NO.	Issue Date	Orig. of Change	Description of Change
**	2489087	See ECN	VKN	This document is recreated from the existing pdf file on web. This is provided a new spec number.

© Cypress Semiconductor Corporation, 2008. The information contained herein is subject to change without notice. Cypress Semiconductor Corporation assumes no responsibility for the use of any circuitry other than circuitry embodied in a Cypress product. Nor does it convey or imply any license under patent or other rights. Cypress products are not warranted nor intended to be used for medical, life support, life saving, critical control or safety applications, unless pursuant to an express written agreement with Cypress. Furthermore, Cypress does not authorize its products for use as critical components in life-support systems where a malfunction or failure may reasonably be expected to result in significant injury to the user. The inclusion of Cypress products in life-support systems application implies that the manufacturer assumes all risk of such use and in doing so indemnifies Cypress against all charges.

Any Source Code (software and/or firmware) is owned by Cypress Semiconductor Corporation (Cypress) and is protected by and subject to worldwide patent protection (United States and foreign), United States copyright laws and international treaty provisions. Cypress hereby grants to licensee a personal, non-exclusive, non-transferable license to copy, use, modify, create derivative works of, and compile the Cypress Source Code and derivative works for the sole purpose of creating custom software and or firmware in support of licensee product to be used only in conjunction with a Cypress integrated circuit as specified in the applicable agreement. Any reproduction, modification, translation, compilation, or representation of this Source Code except as specified above is prohibited without the express written permission of Cypress.

Disclaimer: CYPRESS MAKES NO WARRANTY OF ANY KIND, EXPRESS OR IMPLIED, WITH REGARD TO THIS MATERIAL, INCLUDING, BUT NOT LIMITED TO, THE IMPLIED WARRANTIES OF MERCHANTABILITY AND FITNESS FOR A PARTICULAR PURPOSE. Cypress reserves the right to make changes without further notice to the materials described herein. Cypress does not assume any liability arising out of the application or use of any product or circuit described herein. Cypress does not authorize its products for use as critical components in life-support systems where a malfunction or failure may reasonably be expected to result in significant injury to the user. The inclusion of Cypress' product in a life-support systems application implies that the manufacturer assumes all risk of such use and in doing so indemnifies Cypress against all charges.

Use may be limited by and subject to the applicable Cypress software license agreement.