

REVISIONS

P	LTR	DESCRIPTION	DATE	DWN	APVD
	E2	ECN-22-150900	27APR2022	RK	CSD

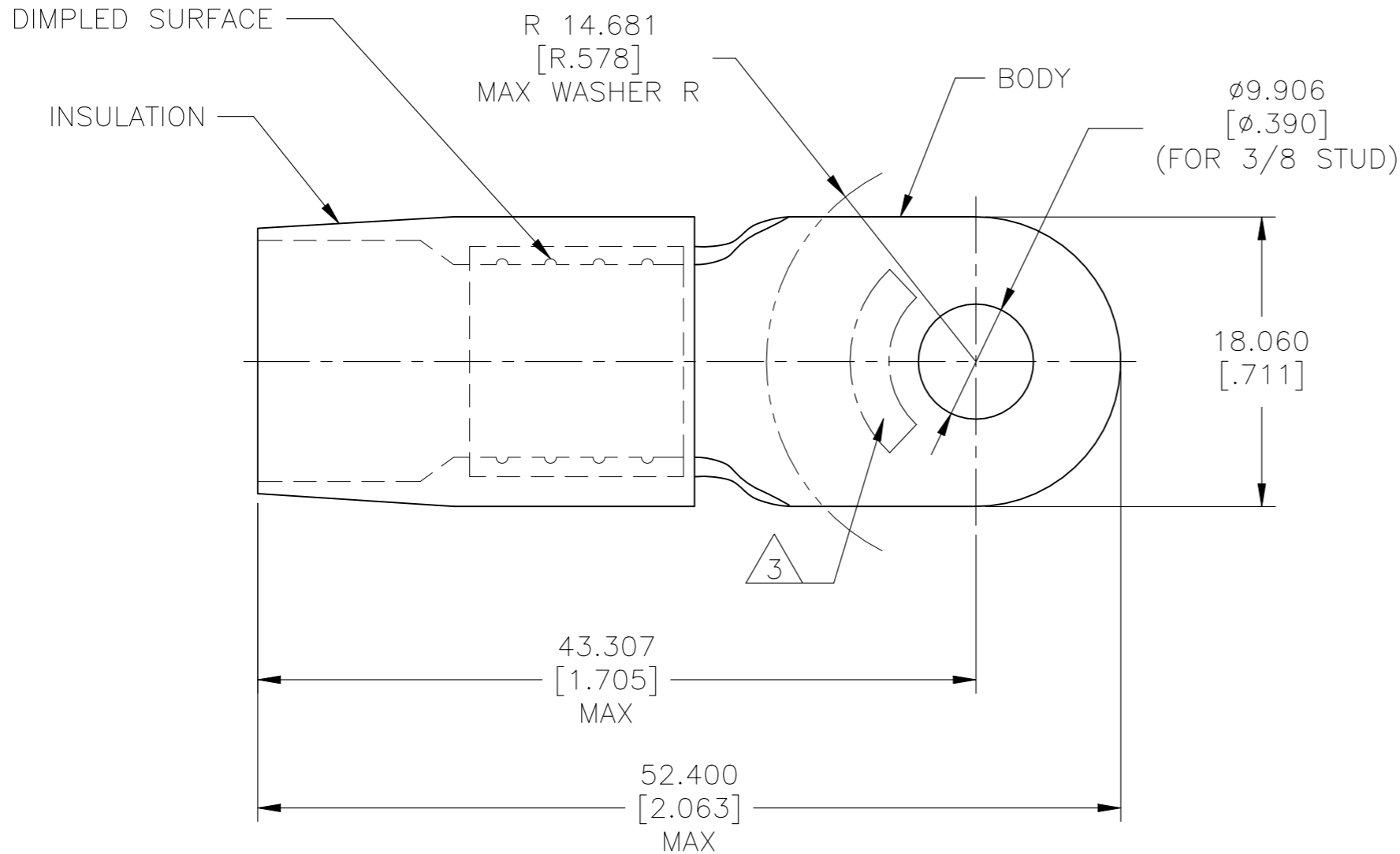

- 1 BODY MATERIAL THK 1.448±0.051[.057±.002]
- 2 FOR Ø11.887[Ø.468] MAX WIRE INS.
- △ 3 STAMP AMP 2\* APPROX AS SHOWN.

50	LOOSE PC	324054
QTY	PACKAGE TYPE	PART NO

AMP INCORPORATED CUSTOMER SERVICE SYSTEMS		MAX RECOMMENDED OPERATING TEMPERATURE: 105°C[221°F]	THIS DRAWING IS A CONTROLLED DOCUMENT.		DWN S.S. GOULDEN 6-21-93	TE Connectivity NAME TERMINAL, RING TONGUE, TERMINYL WIRE SIZE: 2 AWG										
FOR ADDITIONAL PRODUCT INFORMATION OR COPIES OF DRAWINGS AND TECHNICAL DOCUMENTS	PRODUCT INFORMATION CENTER 1-800-522-6752	VOLTAGE RATING: -	DIMENSIONS: mm [INCHES]	TOLERANCES UNLESS OTHERWISE SPECIFIED:	CHK R. HERSEY 6-21-93					APVD B. BARE 6-21-93	PRODUCT SPEC	APPLICATION SPEC	RESTRICTED TO			
FOR APPLICATION TOOLING INFORMATION	TOOLING ASSISTANCE CENTER 1-800-722-1111	CIRCULAR MIL AREA: 26.7-42.4mm² [52,600-83,700] STRANDED			0 PLC ± -	1 PLC ± -	2 PLC ± -	3 PLC ± 0.127[.005]	4 PLC ± -	ANGLES ± -	SIZE A3	CAGE CODE 00779	DRAWING NO C-324054	SCALE NTS	SHEET 1 OF 1	REV E2
FOR ORDER ENTRY	1-800-526-5142	THIS DRAWING IS A CONTROLLED DOCUMENT FOR AMP INCORPORATED. IT IS SUBJECT TO CHANGE AND THE CONTROLLING ENGINEERING ORGANIZATION SHOULD BE CONTACTED FOR THE LATEST REVISION.	MATERIAL BODY: COPPER PER ASTM B-152 INSULATION: NYLON ASTM D4066 TYPE I	FINISH BODY: TIN PLATE PER ASTM B545 INSULATION: COLOR-RED	WEIGHT -	CUSTOMER DRAWING										