

350W FAN COOLED

AC-DC POWER SUPPLIES

The SMP350 series provides a range of rugged, enclosed, 300–350W supplies with integral fan, screw terminal connections and a wide operating temperature range of -40°C to +70°C ideally suited to a wide range of industrial applications. The SMP350 series features high efficiency and class B EMI emissions for ease of integration into the end application and offers remote On/Off to simplify system control. Packaged in a 3.6" x 7" x 1.7" enclosure the series offers power densities up to 13W/in³ providing a compact, high efficiency, low noise power solution.



Features

- Rugged industrial construction
- -40°C to +70°C operation
- Screw terminals
- High efficiency
- Remote On/Off
- ITE/industrial electronics & medical approvals
- Low leakage current option
- Class B emissions
- 3 year warranty

Applications



Healthcare



Industrial Electronics



Instrumentation



Technology

Dimensions

SMP350:

3.6 x 7.0 x 1.7" (91.4 x 177.8 x 43.1 mm)

Models & Ratings

Model Number ⁽¹⁾	Output Voltage	90-180VAC		180-264VAC	
		Output Current	Output Power	Output Current	Output Power
SMP350PS12	12.0VDC	25.00A	300W	25.00A	300W
SMP350PS15	15.0VDC	20.70A	310W	22.00A	330W
SMP350PS18	18.0VDC	17.80A	320W	19.40A	350W
SMP350PS24	24.0VDC	13.75A	330W	14.60A	350W
SMP350PS28	28.0VDC	11.80A	330W	12.50A	350W
SMP350PS36	36.0VDC	9.20A	330W	9.70A	350W
SMP350PS48	48.0VDC	7.30A	350W	7.30A	350W

Notes:

1. For reduced leakage current versions (<300µA) contact sales.

Summary

Characteristic	Minimum	Typical	Maximum	Units	Notes & Conditions
Input Voltage Range	85		264	VAC	Derate from 100% at 90VAC to 90% at 85VAC
No Load Input Power		1.25/2.6		W	115/230VAC when inhibited
Efficiency	87	90	93	%	See fig. 2-4
Operating Temperature	-40		+70	°C	Derate linearly above +50°C to 50% at +70°C, see fig. 5.
EMC	EN55011/32 Level B Conducted & Level A Radiated, EN61000-3-3				
Safety Approvals	IEC62368-1, IEC60601-1, IEC60950-1, EN62368-1, EN60601-1, UL62368-1, CSA C22.2 No. 62368-1, ANSI/AAMI ES60601-1:2005 & CSA C22.2, No.60601-1:08				

Input

Characteristic	Minimum	Typical	Maximum	Units	Notes & Conditions
Input Voltage Range	85		264	VAC	Derate from 100% at 90VAC to 90% at 85VAC
Input Frequency	47		63	Hz	
Power Factor		0.9			EN6100-3-2 for class A, Class C >125W
Input Current			4.7	A	90VAC, 100% load
No Load Input Power		1.25/2.6		W	115 VAC/230VAC when inhibited
Inrush Current		130		A	230VAC, cold start 25°C
Earth Leakage Current			500	µA	264VAC/60Hz. For reduced leakage current medical versions (<300 µA) contact sales.
Fuse Protection	F5.0A/250V fitted in both line and neutral				

Output

Characteristic	Minimum	Typical	Maximum	Units	Notes & Conditions
Output Voltage	12		48	VDC	
Initial Set Accuracy			±1	%	Of nominal at 50% load
Output Voltage Adjustment - V1	±2			%	
Load Regulation			1	%	
Line Regulation			±0.5	%	Of nominal, for input voltage range of 90-264VAC
Ripple and Noise			1	%	Pk-pk with 20MHz bandwidth, 1.5%, 12V models
Hold Up Time	10			ms	
Minimum Load	0			A	No minimum load required
Transient Response			4	%	Deviation with a 50%-75%-50% load change. Output returns to within 1% in less than 500µs
Overvoltage Protection - V1	115		140	% Vnom	Cycle AC to reset
Overload Protection - V1	110		150	%	Trip and restart
Overtemperature Protection					Thermal protection fitted
Remote On/Off	<0.4V to switch off, open cct or >4V to switch on				
Temperature Coefficient			0.02	%/°C	After 20 minute warm up
Start Up Time			1	s	115/230VAC, full load
Overshoot			5	%	

General

Characteristic	Minimum	Typical	Maximum	Units	Notes & Conditions
Efficiency	87	90	93	%	See fig. 2-4 below
Isolation	Input to Output	4000		VAC	2 x MOPP
	Input to Ground	1500			1 x MOPP
	Output to Ground	1500			1 x MOPP
Switching Frequency	60		200	kHz	PFC
	90		150		Main converter
Power Density			13	W/in ³	
Mean Time Between Failure		570		khrs	MIL-HDBK-217F, notice 2, +25°C GB
Weight		1.5 (0.68)		lb (kg)	

Efficiency Graphs

Efficiency vs Load

Figure 2
SMP350PS12

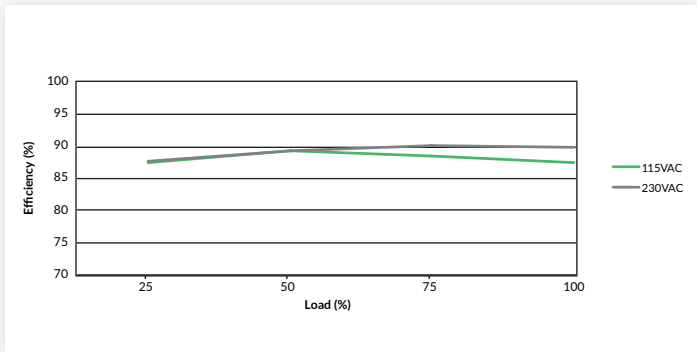

Figure 3
SMP350PS24

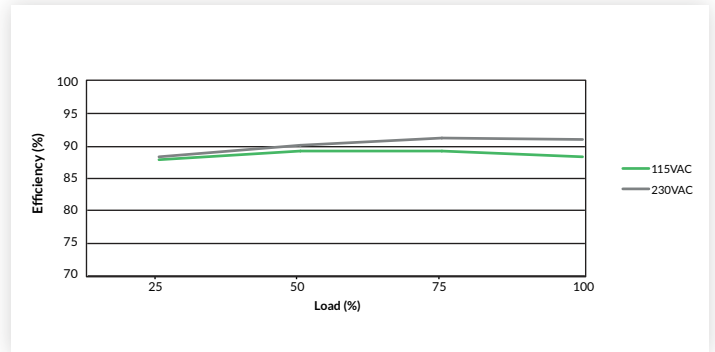
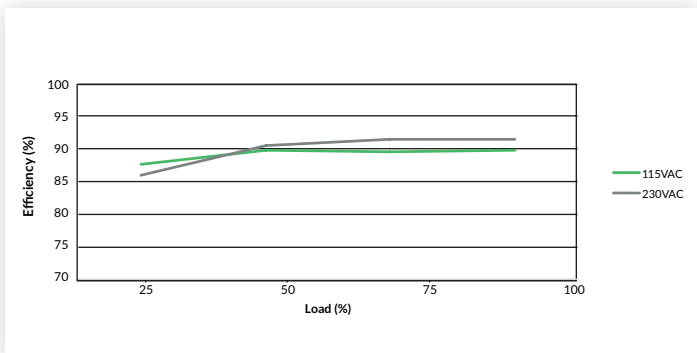

Figure 4
SMP350PS48



Environmental

Characteristic	Minimum	Typical	Maximum	Units	Notes & Conditions
Operating Temperature	-40		+70	°C	Derate linearly above 50°C to 50% of rated power at 70°C, see fig 5
Storage Temperature	-40		+85	°C	
Operating Humidity	5		95	%RH	Non-condensing
Storage Humidity	5		95	%RH	Non-condensing
Shock	±3 x 30g shocks in each plane, total 18 shocks. 30g = 11 ms (±0.5ms), half sine. Conforms to EN60068-2-27 & EN60068-2-47				
Vibration	Single axis 10-500 Hz at 2g sweep and endurance at resonance in all 3 planes. Conforms to EN60068-2-6				

Temperature Derating Curve

Figure 5

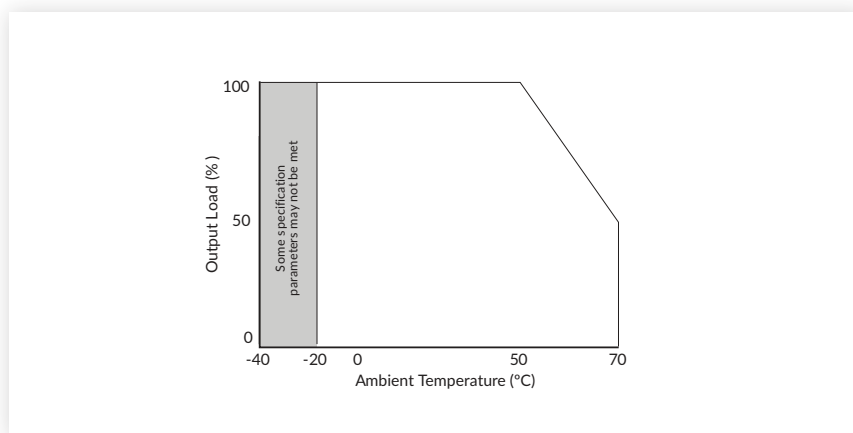

Signals & Controls

Characteristic	Notes & Conditions
Remote Sense	Compensates for 0.5V total voltage drop
Remote On/Off	Inhibit The inhibit lo (pin 4), should be pulled below 0.4V to switch V1 & Vfan off. Open circuit or >4V to switch on (see fig. 6)
	Enable With the inhibit lo (pin 4) pulled low as detailed above, connecting inhibit hi (pin 5) to inhibit lo (pin 4) will enable V1 & V fan output. (see fig. 7)

Remote On/Off (Inhibit)

Figure 6

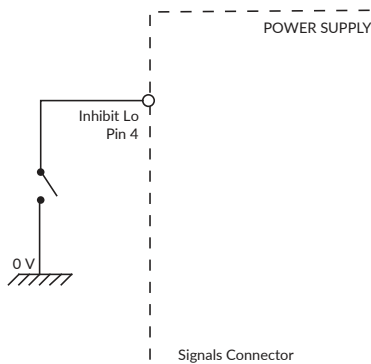

Remote On/Off (Enable)

Figure 7

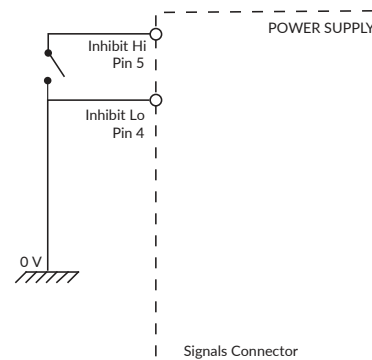

EMC: Emissions

Phenomenon	Standard	Test Level	Notes & Conditions
Conducted	EN55011/32	Class B	
Radiated	EN55011/32	Class A	
Harmonic Fluctuations	EN61000-3-3		

EMC: Immunity

Phenomenon	Standard	Test Level	Criteria	Notes & Conditions
Low Voltage PSU EMC	EN61204-3	High severity level	as below	
Harmonic Current	EN61000-3-2	Class A	A	All models
		Class C		>125W
Radiated	EN61000-4-3	3	A	
EFT	EN61000-4-4	3	A	
Surges	EN61000-4-5	Installation class 3	A	
Conducted	EN61000-4-6	3	A	
Dips and Interruptions	EN61000-4-11 (100VAC)	Dip 100% (0VAC), 8.4ms	A	
		Dip 100% (0VAC), 16.7ms	B	
		Dip 60% (40VAC), 200ms	B	
		Dip 30% (70VAC), 500ms	B	
		Dip 20% (80VAC), 5000ms	B	
		Int 100% (0VAC), 5000ms	B	
	EN61000-4-11 (240VAC)	Dip 100% (0VAC), 10ms	A	
		Dip 100% (0VAC), 20ms	B	
		Dip 60% (96VAC), 200ms	B	
		Dip 30% (168VAC), 500ms	B	
		Dip 20% (192VAC), 5000ms	B	
	EN60601-1-2 (100VAC)	Int 100% (0VAC), 5000ms	B	
		Dip 100% (0VAC), 10ms	A	
		Dip 60% (40VAC), 100ms	A	Derate output power to 150W
		Dip 30% (70VAC), 500ms	A	
	EN60601-1-2 (240VAC)	Int 100% (0VAC), 5000ms	B	
		Dip 100% (0VAC), 10.0ms	A	
		Dip 60% (96VAC), 100ms	A	
		Dip 30% (168VAC), 500ms	A	
	SEMI F47 (100VAC)	Dip 33% (70VAC), 500ms		A

Safety Approvals

Certification	Standard	Notes & Conditions
CB	IEC60950-1:2005 Ed 2 / IEC62368-1 Ed 2	Information Technology
	IEC60601-1 Ed 3.1 Including Risk Management	Medical
UL	UL62368-1 & CSA C22.2 No. 62368-1	Information Technology
	ANSI/AAMI ES60601-1:2005 & CSA C22.2, No.60601-1:08	Medical
TUV	EN62368-1	Information Technology
	EN60601-1/2006	Medical
Equipment Protection Class	Class I	See safety agency conditions of acceptability for details
CE	Meets all applicable directives	
UKCA	Meets all applicable legislation	
Isolation	Means of Protection	Category
Primary to Secondary	2 x MOPP (Means of Patient Protection)	IEC60601-1 Ed 3
Primary to Earth	1 x MOPP (Means of Patient Protection)	IEC60601-1 Ed 3
Secondary to Earth	1 x MOPP (Means of Patient Protection)	IEC60601-1 Ed 3

Mechanical Details

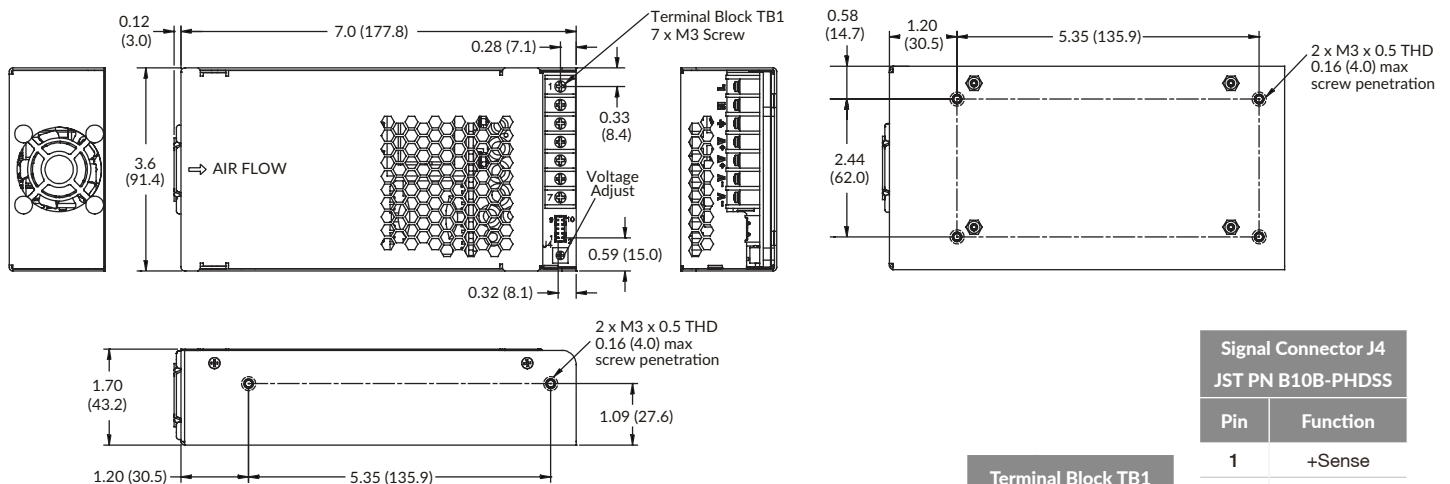

Terminal Block TB1	
Pin	Function
1	Line
2	Neutral
3	Ground
4	+V1
5	+V1
6	-V
7	-V

Signal Connector J4 JST PN B10B-PHDSS	
Pin	Function
1	+Sense
2	-Sense
3	XP Internal Use
4	Inhibit LO
5	Inhibit HI
6	N/C
7	N/C
8	N/C
9	N/C
10	N/C

Notes:

- All dimensions in inches (mm).
- Tolerance .xx = 0.02 (0.50); .xxx = 0.01 (0.25)
- Weight: 1.5lbs (0.68 kg)

- J4 mates with JST Housing Pn. PHDR-10VS and with JST SPHD-001T-P0.5 crimp terminals.