



**QUICKSWITCH® PRODUCTS  
HIGH-PERFORMANCE CMOS  
SIX CHANNEL SP4T MUX/DEMUX**

**IDTQS4A215**

**FEATURES:**

- Low ON resistance:  $r_{DS(ON)} = 5\Omega$
- Fast transition time:  $t_{TRAN} = 6ns$
- Wide bandwidth: 700MHz (-3dB point)
- Crosstalk: -110dB at 50KHz, -68dB at 5MHz, -66dB at 30MHz
- Off-isolation: -90dB at 50KHz, -60dB at 5MHz, -50dB at 30MHz
- Single 5V supply
- Can be used as multiplexer or demultiplexer
- TTL-compatible control inputs
- Ultra-low quiescent current:  $9\mu A$
- Available in QVSOP package

**APPLICATIONS:**

- High-speed video signal switching/routing
- HDTV-quality video signal multiplexing
- Audio signal switching/routing
- Data acquisition
- ATE systems
- Telecomm routing
- Switch between multiple video sources
- Token Ring transceivers
- High-speed networking

**DESCRIPTION:**

The QS4A215 is a high-performance CMOS six-channel multiplexer/demultiplexer with individual enables. The low ON-resistance of the QS4A215 allows inputs to be connected to outputs with low insertion loss and high bandwidth. TTL-compatible control circuitry with "Break-Before-Make" feature prevents contention.

The QS4A215 with 700MHz bandwidth makes it ideal for high-performance video signal switching, audio signal switching, and telecom routing applications. High performance and low power dissipation makes this device ideal for battery operated and remote instrumentation applications.

The QS4A215 is offered in the QVSOP package which has several advantages over conventional packages such as PDIP and SOIC, including:

- Reduced signal delays due to denser component packaging on circuit boards
- Reduced system noise due to less pin inductance, resulting in lower ground bounce

The QS4A215 is characterized for operation at  $-40^{\circ}C$  to  $+85^{\circ}C$ .

**FUNCTIONAL BLOCK DIAGRAM**

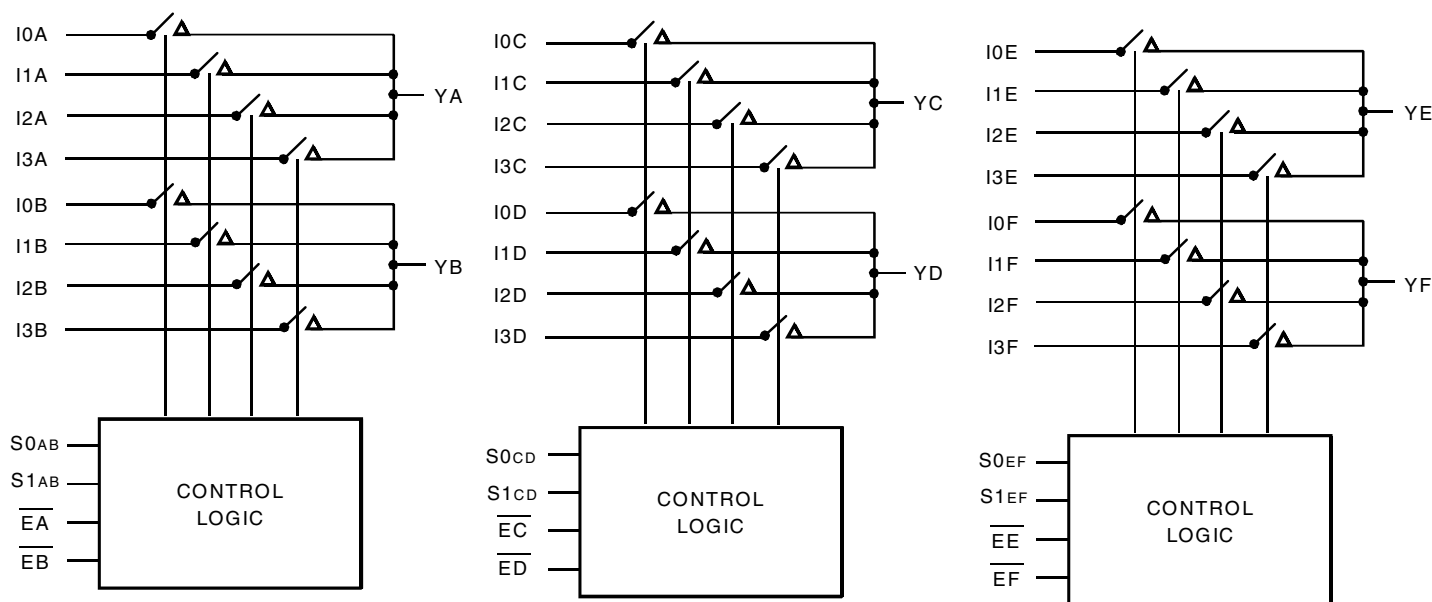

IDT and the IDT logo are registered trademarks of Integrated Device Technology, Inc.

### PIN CONFIGURATION

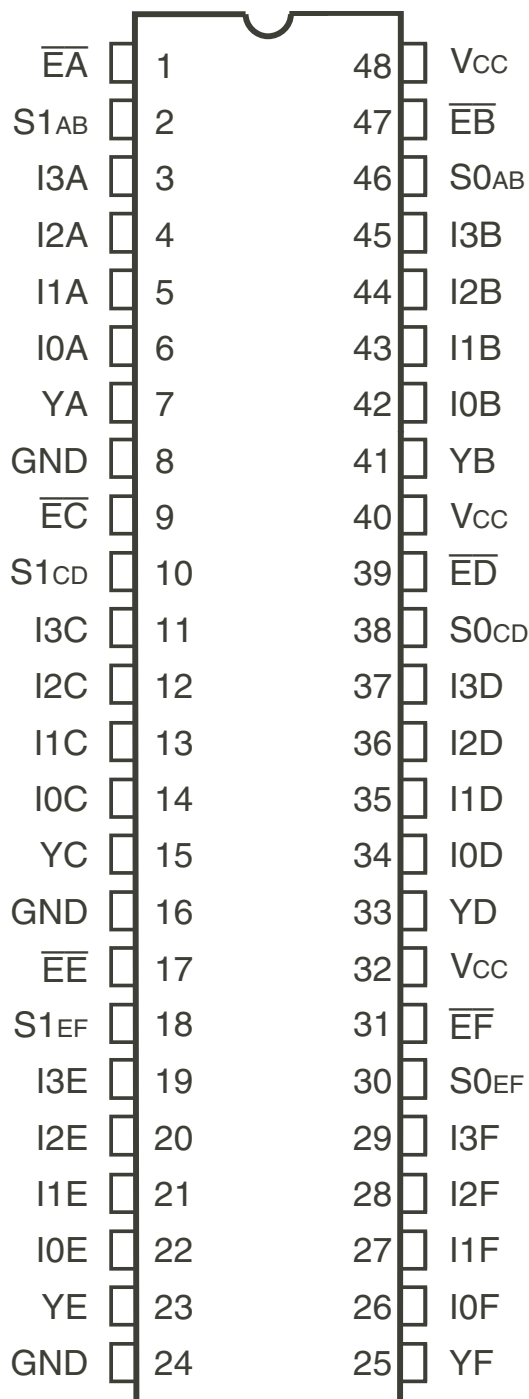

QVSOP  
TOP VIEW

### ABSOLUTE MAXIMUM RATINGS<sup>(1)</sup>

Symbol	Description	Max	Unit
VTERM <sup>(2)</sup>	Supply Voltage to Ground	-0.5 to +7	V
VTERM <sup>(3)</sup>	DC Switch Voltage Vs	-0.5 to +7	V
—	Analog Input Voltage	-0.5 to +7	V
VTERM <sup>(3)</sup>	DC Input Voltage VIN	-0.5 to +7	V
VAC	AC Input Voltage (pulse width ≤20ns)	-3	V
IOUT	DC Output Current	120	mA
PMAX	Maximum Power Dissipation	0.7	W
TSTG	Storage Temperature	-65 to +150	°C

NOTES:

- Stresses greater than those listed under ABSOLUTE MAXIMUM RATINGS may cause permanent damage to the device. This is a stress rating only and functional operation of the device at these or any other conditions above those indicated in the operational sections of this specification is not implied. Exposure to absolute maximum rating conditions for extended periods may affect reliability.
- V<sub>CC</sub> terminals.
- All terminals except V<sub>CC</sub>.

### PIN DESCRIPTION

Pin Names	I/O	Description
Ixx	I/O	Demux Ports A-F
S0xx, S1xx	I	Select Inputs
EX	I	Enable Inputs A-F
Yx	I/O	Mux Ports A-F

### FUNCTION TABLE<sup>(1)</sup>

Enable		Select		Mux/Demux Ports		Function
EA	EB	S1	S0	YA	YB	
H	X	X	X	Z	X	Disable A
X	H	X	X	X	Z	Disable B
L	L	L	L	I0A	I0B	S1AB, S0AB = 0
L	L	L	H	I1A	I1B	S1AB, S0AB = 1
L	L	H	L	I2A	I2B	S1AB, S0AB = 2
L	L	H	H	I3A	I3B	S1AB, S0AB = 3

NOTE:

- H = HIGH Voltage Level  
L = LOW Voltage Level  
X = Don't Care  
Z = High-Impedance
- This function table represents the function for block "AB". The "CD" block nomenclature substitutes "A" for "C" and "B" for "D". The "EF" block nomenclature substitutes "A" for "E" and "B" for "F".

## DC ELECTRICAL CHARACTERISTICS OVER OPERATING RANGE

Following Conditions Apply Unless Otherwise Specified:

Industrial:  $T_A = -40^{\circ}\text{C}$  to  $+85^{\circ}\text{C}$ ,  $V_{CC} = 5\text{V} \pm 5\%$

Symbol	Parameter	Test Conditions	Min.	Typ. <sup>(1)</sup>	Max.	Unit
<i>Analog Switch</i>						
$V_{IN}$	Analog Signal Range <sup>(2)</sup>		-0.5	1	$V_{CC} - 1$	V
$r_{DS(ON)}$	Drain-source ON resistance <sup>(2,3)</sup>	$V_{CC} = \text{Min.}, V_{IN} = 0\text{V}, I_{ON} = 30\text{mA}$	—	5	7	$\Omega$
		$V_{CC} = \text{Min.}, V_{IN} = 2.4\text{V}, I_{ON} = 15\text{mA}$	—	13	17	
$I_{C(OFF)}$	Channel Off Leakage Current	$I_N = V_{CC}$ or $0\text{V}$ ; $Y_N = 0\text{V}$ or $V_{CC}$ ; $\overline{EX} = V_{CC}$	—	10	—	nA
$I_{C(ON)}$	Channel On Leakage Current	$I_N = Y_N = 0\text{V}$ (each channel is turned on sequentially)	—	10	—	nA
<i>Digital Control</i>						
$V_{IH}$	Input HIGH Voltage	Guaranteed Logic HIGH for Control Pins	2	—	—	V
$V_{IL}$	Input LOW Voltage	Guaranteed Logic LOW for Control Pins	—	—	0.8	V
<i>Dynamic Characteristics</i>						
$t_{TRANS}$	Switching Time of Mux Sx to Yx	$R_L = 1\text{K}\Omega, C_L = 100\text{pF}$ (See Transition Time)	0.5	—	6.6	ns
$t_{ON(\overline{EN})}$	Enable Turn-On Time $\overline{EX}$ to Yx	$R_L = 1\text{K}\Omega, C_L = 100\text{pF}$ (See Switching Time)	0.5	—	6	ns
$t_{OFF(\overline{EN})}$	Enable Turn-Off Time $\overline{EX}$ to Yx	$R_L = 1\text{K}\Omega, C_L = 100\text{pF}$ (See Switching Time)	0.5	—	6	ns
$t_{PD}$	Group Delay <sup>(2,4)</sup>	$R_L = 1\text{K}\Omega, C_L = 100\text{pF}$	—	—	250	ps
$f_{dB}$	-3dB Bandwidth	$V_{IN} = 1\text{Vp-p}, R_L = 75\Omega$	—	700	—	MHz
	Off-isolation	$V_{IN} = 1\text{Vp-p}, R_L = 75\Omega, f = 5\text{MHz}$	—	-60	—	dB
X TALK	Crosstalk	$V_{IN} = 1\text{Vp-p}, R_L = 75\Omega, f = 5\text{MHz}$	—	-68	—	dB
$C_{MUX(OFF)}$	Mux Off Capacitance	$\overline{EX} = V_{CC}, V_{IN} = V_{OUT} = 0\text{V}$	—	6	—	pF
$C_{DEMUX(OFF)}$	Demux Off Capacitance	$\overline{EX} = V_{CC}, V_{IN} = V_{OUT} = 0\text{V}$	—	14	—	pF
$C_{MUX(ON)}$	Mux On Capacitance	$\overline{EX} = 0\text{V}, V_{IN} = V_{OUT} = 0\text{V}$	—	20	—	pF
$C_{DEMUX(ON)}$	Demux On Capacitance	$\overline{EX} = 0\text{V}, V_{IN} = V_{OUT} = 0\text{V}$	—	20	—	pF
QCI	Charge Injection	$C_L = 1000\text{pF}$	—	1.5	—	pC

### NOTES:

- Typical values are at  $V_{CC} = 5.0\text{V}$ ,  $T_A = 25^{\circ}\text{C}$ .
- Max value is guaranteed but not production tested.
- Measured by voltage drop between A and C pins or B and D pins at indicated current through the switch. ON resistance is determined by the lower of the voltages on the two (I, Y) pins.
- The bus switch contributes no group delay other than the RC delay of the ON resistance of the switch and load capacitance. Group delay of the bus switch, when used in a system, is determined by the driving circuit on the driving side of the switch and its interaction with the load on the driven side.

## POWER SUPPLY CHARACTERISTICS

Symbol	Parameter	Test Conditions	Max.	Unit
$I_{CCQ}$	Quiescent Power	$V_{CC} = \text{Max.}, V_{IN} = \text{GND}$ or $V_{CC}, f = 0$	9	$\mu\text{A}$

### TYPICAL CHARACTERISTICS

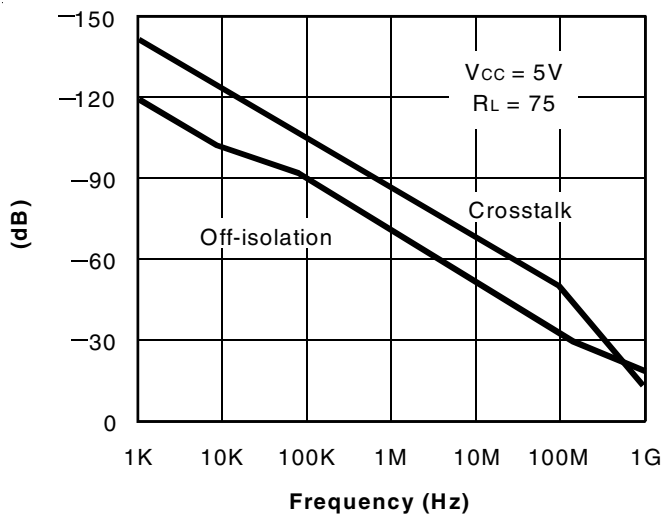

Off-isolation and Crosstalk vs. Frequency

NOTES:  
1. Crosstalk =  $20 \log |V_o/V_s|$   
2. Off-isolation =  $20 \log |V_o/V_s|$

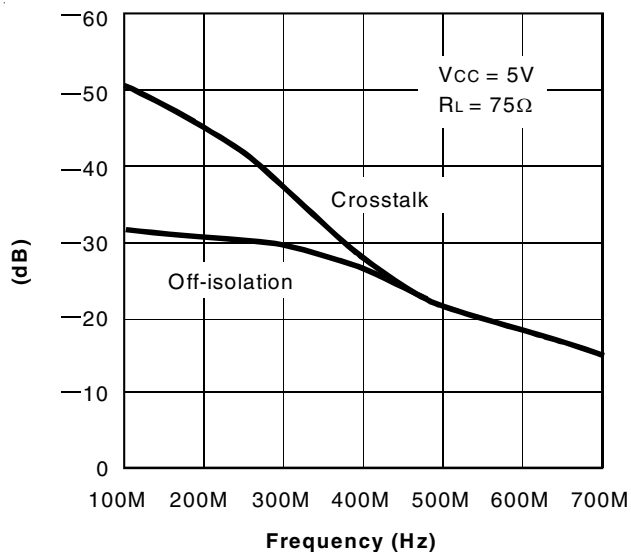

Off-isolation and Crosstalk vs. Frequency

NOTES:  
1. Crosstalk =  $20 \log |V_o/V_s|$   
2. Off-isolation =  $20 \log |V_o/V_s|$

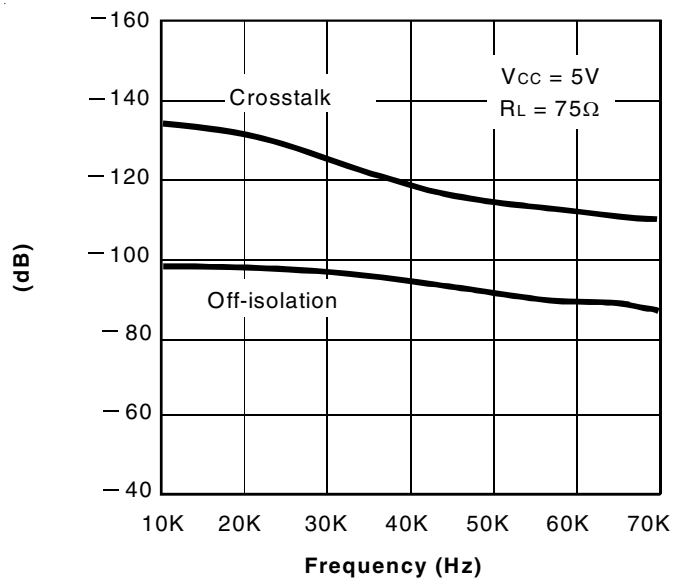

Off-isolation and Crosstalk vs. Frequency

NOTES:  
1. Crosstalk =  $20 \log |V_o/V_s|$   
2. Off-isolation =  $20 \log |V_o/V_s|$

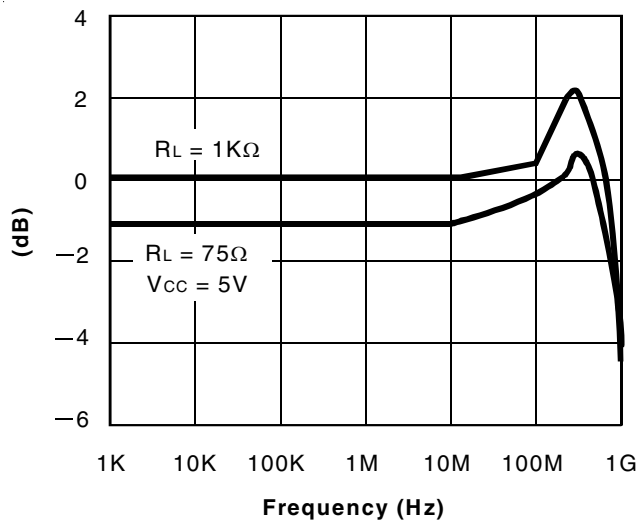

Insertion Loss vs. Frequency

NOTE:  
1. Insertion Loss =  $20 \log |V_o/V_s|$

### TYPICAL CHARACTERISTICS (CONTINUED)

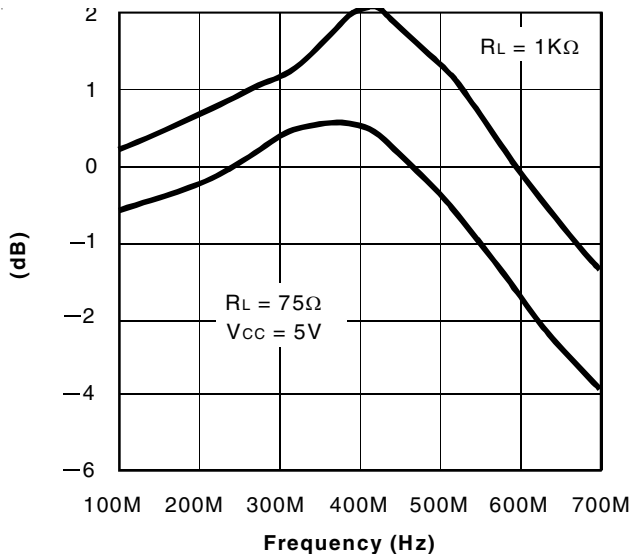

Insertion Loss vs. Frequency

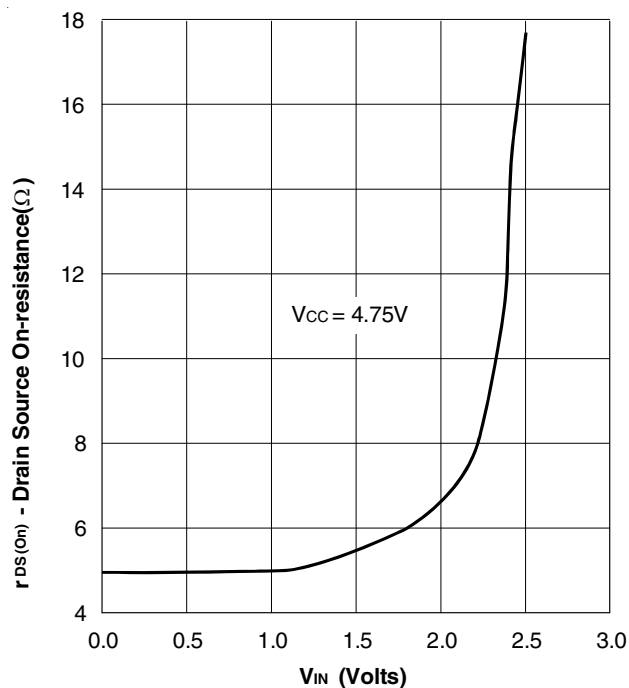

RON LINK

On-Resistance vs. VIN

NOTE:  
1. Insertion Loss =  $20 \log |V_o/V_s|$

### TEST CIRCUITS

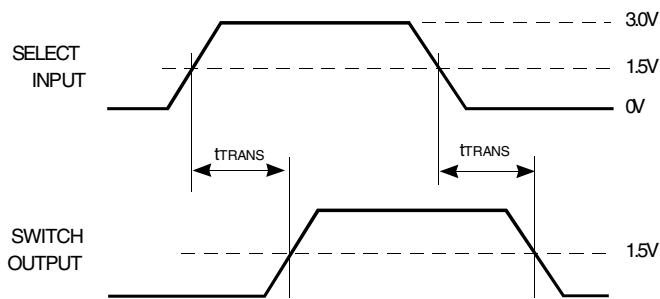
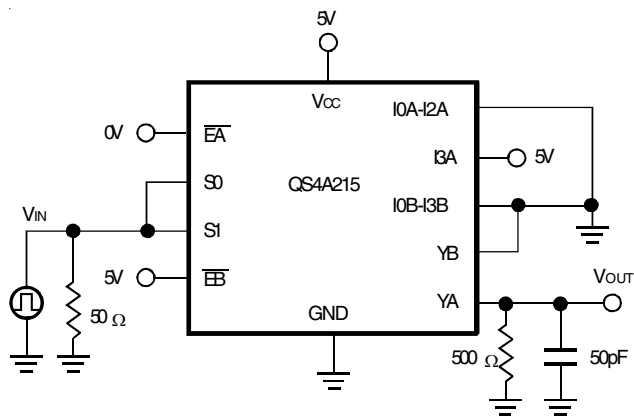

Transition Time

TEST CIRCUITS (CONTINUED)

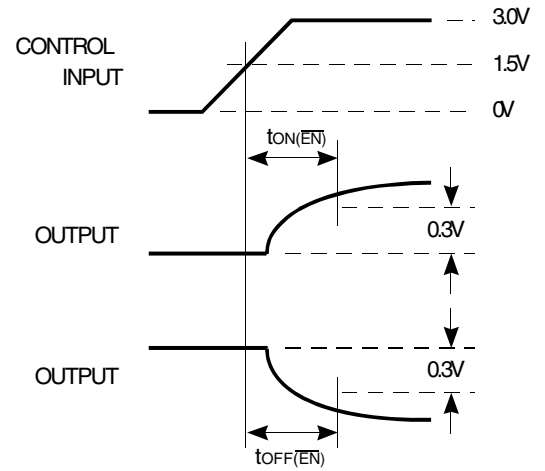
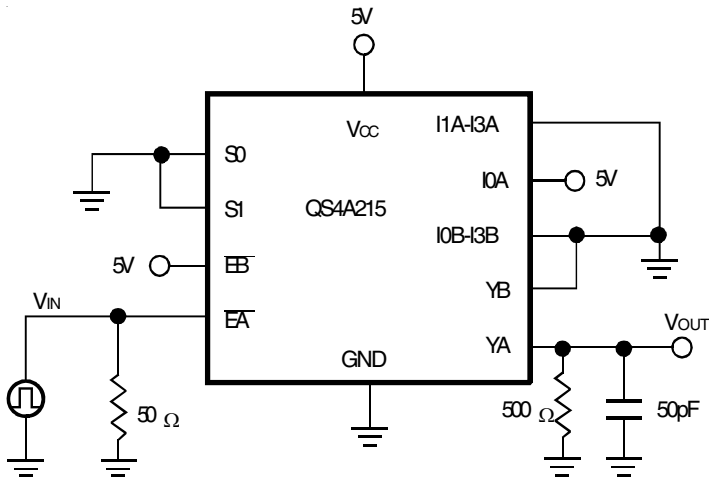

Enable Switching Time

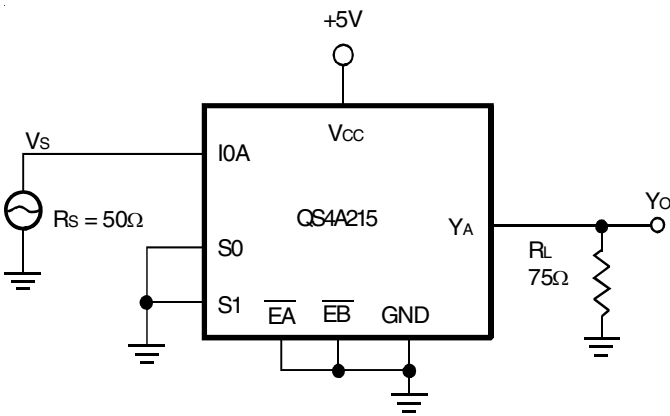

Insertion Loss

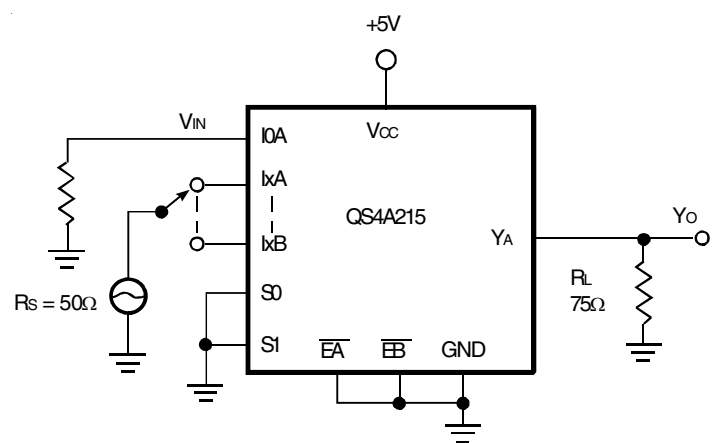

Crosstalk

NOTE:  
1. Insertion Loss =  $20 \log |V_o/V_s|$

NOTE:  
1. Crosstalk =  $20 \log |V_o/V_s|$

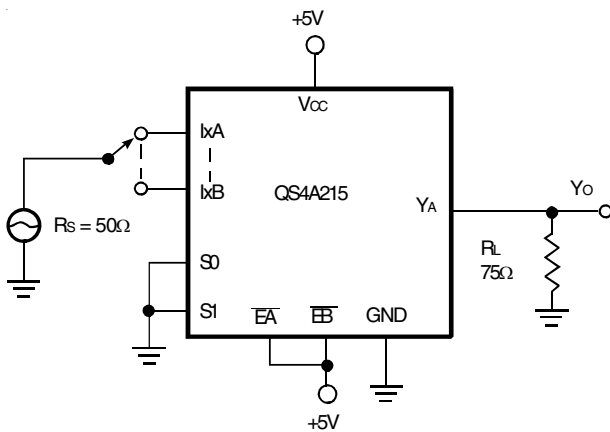

Off-Isolation

NOTE:  
1. Off-isolation =  $20 \log |V_o/V_s|$

## ORDERING INFORMATION

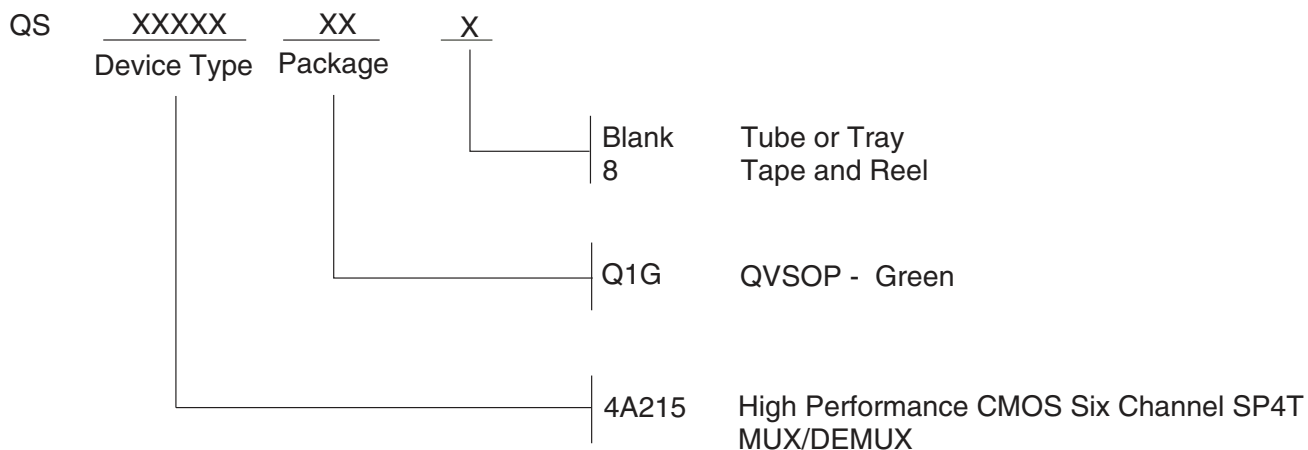

## DATASHEET DOCUMENT HISTORY

04/13/2014	Pg. 7	Updated the Ordering Information by removing non green package version, the "IDT" notation and Adding Tape and Reel information.
07/07/2015	Pg. 1,7	Updated the Ordering Information from QG to Q1G accordingly.



*CORPORATE HEADQUARTERS*  
6024 Silver Creek Valley Road  
San Jose, CA 95138

*for SALES:*  
800-345-7015 or 408-284-8200  
fax: 408-284-2775  
www.idt.com

*for Tech Support:*  
logichelp@idt.com