

## SPECIFICATION CONTROL DRAWING

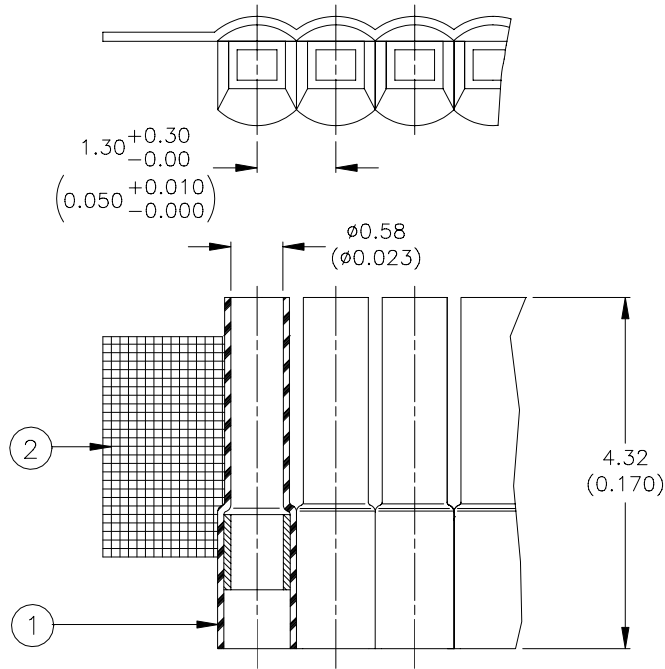

### MATERIALS

1. SOLDERSLLEEVE WIRE TERMINATOR: D-141-0169, Quantity Per Assembly: 1000
2. CARRIER STRIP: Adhesive Coated High Temperature Tape

### APPLICATION

1. This assembly is designed to be used on Raychem MTC50-YXX-015/-016 connectors. See Raychem Specification Control Drawing D-141-0169 for wire accommodation.
2. Wire terminators are to be inspected to Raychem Devices Specification Control Drawing D-141-0169.

 307 Constitution Drive, Menlo Park, CA 94025, USA		<b>Wire and Harnessing Products</b>	TITLE: <b>SOLDERPAK ASSEMBLY FOR MTC50 CONNECTORS</b>				
Unless otherwise specified dimensions are in millimeters. Inches dimensions are in between brackets.			DOCUMENT NO.: <b>D-713-0006</b>				
TOLERANCES: 0.00 N/A 0.0 N/A 0 N/A	ANGLES: N/A  ROUGHNESS IN MICRON	Tyco Electronics reserves the right to amend this drawing at any time. Users should evaluate the suitability of the product for their application.	DCR NUMBER: D010442	REPLACES: N/A			
DRAWN BY: M. FORONDA	DATE: 18-July-01	PROD. REV. A	DOC ISSUE: 1	SCALE: None	SIZE: A	SHEET: 1 of 1	

If this document is printed it becomes uncontrolled. Check for the latest revision.