

TPS23880EVM: PoE, PSE, TPS23880 Evaluation Module

This user's guide describes the evaluation modules (EVM) for the TPS23880 (TPS23880EVM-008 and BOOST-PSEMTHR-007). The EVM contains evaluation and reference circuitry for the TPS23880. The TPS23880 is a Power-over-Ethernet (PoE) device for power sourcing equipment (PSE).

Contents

1	Description	2
2	Quick Start	2
3	General Use Features	6
4	TPS23880EVM GUI Setup	8
5	EVM Schematic, Layout Guidelines and PCB Assembly, Layer Plots	21
6	Bill of Materials	32

List of Figures

1	Basic Setup Using USB2ANY	4
2	Advanced Setup Using LaunchPad™	5
3	TPS23880EVM GUI SRAM Loading Window	8
4	TPS23880EVM GUI Startup Window	9
5	Device Configuration and Port Telemetry Page	10
6	Register Map	10
7	SRAM Code Load	11
8	Program Started	12
9	Terminal Response With Connected Ports	13
10	Auto Mode System Software Structure	15
11	Semi Auto Mode System Software Structure	16
12	Power on Decision Flow Chart	19
13	System Power Monitor Flow Chart	19
14	BOOST-PSEMTHR-007 (Motherboard) Schematic: Control	22
15	BOOST-PSEMTHR-007 (Motherboard) Schematic: Power Ports	23
16	TPS23880EVM-008 (Daughterboard) Schematic	24
17	BOOST-PSEMTHR-007 (Motherboard) Top Side Assembly	25
18	BOOST-PSEMTHR-007 (Motherboard) Top Side Routing	26
19	BOOST-PSEMTHR-007 (Motherboard) Layer 2 Routing	27
20	BOOST-PSEMTHR-007 (Motherboard) Layer 3 Routing	28
21	BOOST-PSEMTHR-007 (Motherboard) Bottom Side Routing	29
22	TPS23880EVM-008 (Daughterboard) Top Side Assembly	30
23	TPS23880EVM-008 (Daughterboard) Top Side Routing	30
24	TPS23880EVM-008 (Daughterboard) Bottom Side Routing	31
25	TPS23880EVM-008 (Daughterboard) Bottom Side Assembly	31

List of Tables

1	TPS23880EVM Voltage Rail Current Requirements	3
2	EVM Input/Output Connectors	6
3	EVM LEDs	6

<i>Description</i>	www.ti.com
4 EVM Test Points	7
5 EVM Jumpers	7
6 Terminology	17
7 State Definitions	17
8 Function Definitions	18
9 User Configurable Parameters	18
10 BOOST-PSEMTHR-007 Bill of Materials	32
11 TPS23880EVM-008 Bill of Materials	34

Trademarks

LaunchPad, Code Composer Studio are trademarks of Texas Instruments.
All other trademarks are the property of their respective owners.

1 Description

The TPS23880EVM features the 8-channel, TPS23880, IEEE 802.3bt (draft) PoE PSE controller. The EVM consists of a motherboard (BOOST-PSEMTHR-007) and a daughterboard (TPS23880EVM-008) containing one TPS23880 device. The TPS23880EVM provides a multi-port base platform interface for TPS23880EVM-008, [MSP-EXP430FR5969](#) (LaunchPad™), and [USB2ANY](#) (USB Interface Adapter).

1.1 Features

The EVM supports the following features:

- Four IEEE802.3bt (draft) 2-pair ports with 1000BASE-T (gigabit Ethernet data pass-through)
- Two IEEE802.3bt (draft) 4-pair ports with 1000BASE-T (gigabit Ethernet data pass-through)
- Single DC power supply input
- Onboard 3.3-V regulator
- Onboard I²C interface to both TPS23880 devices from either [USB2ANY](#) or [MSP-EXP430FR5969](#).
- Port ON status LEDs
- User test points

1.2 Applications

The EVM is used in the following applications:

- Enterprise and SoHO switches and routers
- Connected ceiling LED switches
- PoE pass-through power modules
- Network video recorders (NVRs)
- Wireless backhaul and small-cell networking

2 Quick Start

2.1 Input Power

2.1.1 Input Power (Labeled VPWR)

The DC input voltage is provided through J1 (screw jack). A DC power supply or wall adapter with sufficient current capacity can power the EVM.

CAUTION

Reverse voltage protection is not provided; ensure that the correct polarity is applied to J1.

This DC input is labeled *VPWR* in the schematics and is used for port VBUS as well as for the TPS23880 devices. The *VPWR* connections to the PoE ports are not fused. Each two-pair port is capable of furnishing at least 30 W and each four-pair port can furnish 90 W.

The minimum PSE port voltage is 44 VDC for type 1, 50 V for type 2 and type 3, and 52 V for type 4. During evaluation, choose the appropriate DC power supply for different environments.

2.1.2 Local 3.3 V (Labeled 3.3V)

Local 3.3 V for local devices (labeled as 3.3V) is provided by the onboard LM5019 buck converter. The LM5019 provides a basic power-on sequence and provides a well-controlled and consistent startup. In addition to 54 V, the TPS23880 requires 3.3 V for the digital circuitry and this is routed up to TPS23880EVM-008 over the connector interface. The current consumption is 6-mA typical and 12-mA maximum.

2.1.3 External 3.3 V (Labeled 3.3V_USB)

The BOOST-PSEMTHR-007 provides galvanic isolation between the PoE power side and host side using digital isolators (ISO7241CD). The host side power is provided either from J2 (from [USB2ANY](#)) or J5 (from [MSP-EXP430FR5969](#)).

CAUTION

Do not use USB2ANY and LaunchPad simultaneously.

Table 1. TPS23880EVM Voltage Rail Current Requirements

Voltage Rail	Typical (mA)	Maximum (mA)
3.3V_USB	2.5	3
3.3V	6	12
VPWR (Miscellaneous)	35	57
VPWR (4 × 2 Pair Ports and 2 × 4 pair Ports)	5556	5578
VPWR Total (4 × 2 Pair Ports and 2 × 4 pair Ports)	5591	5613

2.2 PoE Port Interfaces

The TPS23880 device must be configured through the host to become operational. This EVM provides 2 ways to control the TPS23880: TPS23880EVM GUI (with [USB2ANY](#)) and [MSP-EXP430FR5969](#) LaunchPad.

2.2.1 IEEE802.3bt (draft) 2-Pair Ports

Four 2-pair ports are provided at J19, J20, J8, and J7 for 2-pair ports 1, 2, 3, and 4 respectively. The power furnished is according to alternative A with MDI-X polarity.

2.2.2 IEEE802.3bt (draft) 4-Pair Ports

Two 4-pair high power ports are provided at J21 and J9 for 4-pair ports 1 and 2, respectively. The power furnished is according to alternative A with MDI-X polarity and alternative B with S polarity on a single port connector. A single- or dual-signature PD may be powered by the 4-pair ports with proper port configuration (enabling 4-pair mode).

2.3 I²C Interfaces

Two I²C interfaces to the TPS23880 are provided on the EVM.

2.3.1 USB2ANY

J2 provides an interface with the [USB2ANY](#) adapter when using a PC and GUI.

2.3.2 MSP-EXP430FR5969

J3, J4, and J5 provide an interface with the [MSP-EXP430FR5969](#) when using a PC to develop custom system software.

2.4 Basic Test Setup Using USB2ANY for PC Interface (Auto Mode or Semi-Auto Mode Operation with PC Monitoring)

An I²C interface is provided through J2 to the TPS23880 devices on the TPS23880EVM-008. The USB2ANY adapter (not included) can be used with any TI GUI which uses USB2ANY to read and write over an I²C bus. [Figure 1](#) illustrates the basic setup using USB2ANY.

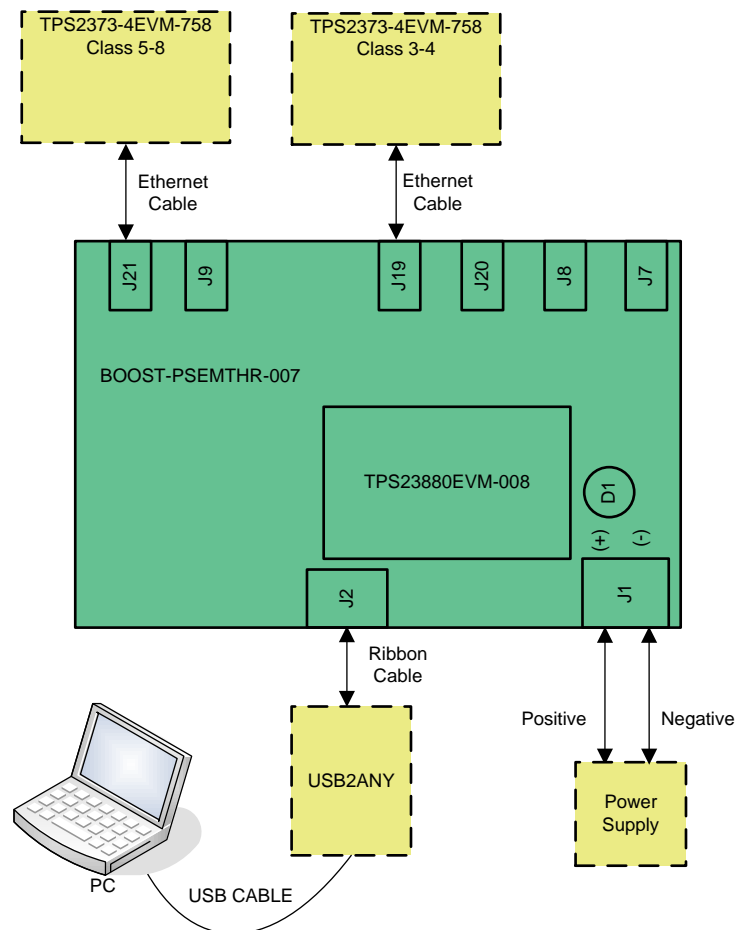

Figure 1. Basic Setup Using USB2ANY

2.5 Advanced Test Setup Using MSP-EX430FR5969 (LaunchPad™)

The LaunchPad (not included) running a custom software program can communicate with the TPS23880 devices on the TPS23880EVM-008. [Figure 2](#) shows the advanced setup using LaunchPad.

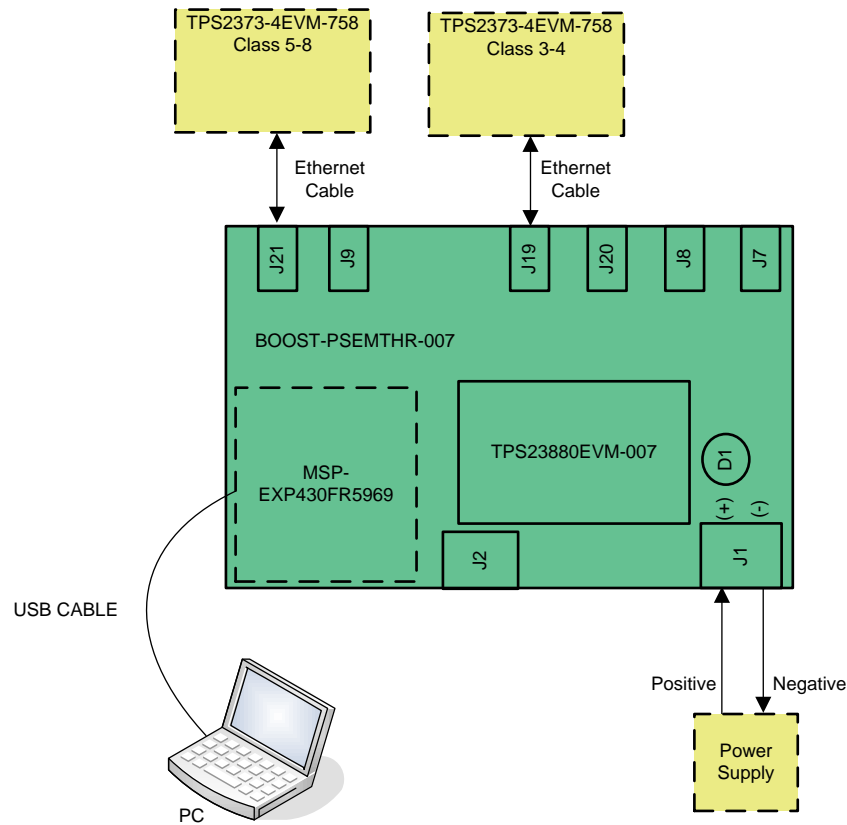

Figure 2. Advanced Setup Using LaunchPad™

3 General Use Features

3.1 EVM Input/Output Connectors and Switches

Table 2 lists the EVM input and output connectors.

Table 2. EVM Input/Output Connectors

Connector or Switch	Label	Description
J1	J1	DC power supply screw jack. (44–57 VDC). Use a 48 VDC (nominal) for type 1 and 54 VDC (nominal) for type 2, 3, and 4 PSE operation.
J2	J2	Ribbon cable connection to USB2ANY adapter
J3	J3	LaunchPad control (mates with LaunchPad J1)
J4	J4	LaunchPad I ² C (mates with LaunchPad J2)
J5	J5	LaunchPad power (onboard, mates with LaunchPad J6)
J6	J6	TPS23880EVM-008 control (mates with TPS23880EVM-008 J3)
J17	J17	TPS23880EVM-008 Channel 5–8 (mates with TPS23880EVM-008 J2)
J18	J18	TPS23880EVM-008 Channel 1–4 (mates with TPS23880EVM-008 J1)
J22	J22	Two-pair port 1 data only
J19	2 Pair Port 1	Two-pair port 1 power and data
J23	J23	Two-pair port 2 data only
J20	2 Pair Port 2	Two-pair port 2 power and data
J11	J11	Two-pair port 3 data only
J8	2 Pair Port 3	Two-pair port 3 power and data
J10	J10	Two-pair port 4 data only
J7	2 Pair Port 4	Two-pair port 4 power and data
J24	J24	Four-pair port 1 data only
J21	4 Pair Port 1	Four-pair port 1 power and data
J12	J12	Four-pair port 2 data only
J9	4 Pair Port 2	Four-pair port 2 power and data
J29	J29	Chassis ground tie point

3.2 EVM LEDs

Table 3 lists the EVM LEDs and their descriptions.

Table 3. EVM LEDs

LED	Color	Label	Description
D1	GREEN	48V	48-V ON indicator
D16	BLUE	D13	Two-pair port 1 power is ON. For J19 supplier #1 (see the bill of materials (BOM)), J19 internal port LED is active. For supplier #2, D16 is active.
D17	BLUE	D15	Two-pair port 2 power is ON. For J20 supplier #1 (see the BOM), J20 internal port LED is active. For supplier #2, D17 is active.
D13	BLUE	D14	Two-pair port 3 power is ON. For J8 supplier #1 (see the BOM), J8 internal port LED is active. For supplier #2, D13 is active.
D12	BLUE	D12	Two-pair port 4 power is ON. For J7 supplier #1 (see the BOM), J7 internal port LED is active. For supplier #2, D12 is active.

3.3 EVM Test Points

Table 4 lists and describes the EVM test points.

Table 4. EVM Test Points

TP	Color	Label	Description
Motherboard: BOOST-PSEMTHR-007			
TP1	RED	VPWR	Used for VPWR
TP2	RED	3.3V	Used for TPS23880 VDD
TP3	SMT	GND	VPWR ground
TP4	WHT	SDA	I ² C Data from LaunchPad and USB-TO-GPIO
TP5	WHT	SCL	I ² C Clock from LaunchPad and USB-TO-GPIO
TP6	WHT	PSE_SDAO	I ² C data out from TPS23880
TP7	WHT	PSE_SCL	I ² C clock to TPS23880
TP8	WHT	PSE_SDAI	I ² C data in to TPS23880
TP9	BLK	GND1	Ground from LaunchPad and USB2ANY
TP11	SMT	TP11	Chassis ground test point
TP14	SMT	GND	VPWR ground test point
TP15	SMT	GND	VPWR ground test point
TP16	SMT	GND	VPWR ground test point
Daughterboard: TPS23880EVM-008			
TP2	RED	2P4D	Two-pair port 4 DRAIN
TP3	WHT	2P4G	Two-pair port 4 GATE
TP4	WHT	4P1AG	Four-pair port 1A GATE
TP5	RED	4P1AD	Four-pair port 1A DRAIN
TP7	WHT	4P1BG	Four-pair port 1B GATE
TP6	RED	4P1BD	Four-pair port 1B DRAIN
TP1	BLK	GND	VPWR ground
TP8	SMT	GND	VPWR ground

3.4 EVM Test Jumpers

The EVM is equipped with shunts on the jumper positions identified in Table 5, in the *Default Pin Position* column. Shunts can be moved and removed, as required, during use.

Table 5. EVM Jumpers

Jumper	Default Pin Position	Label	Description
Motherboard: BOOST-PSEMTHR-007			
J27	1-2	P1	Two-pair port 1 LED bias
J28	1-2	P2	Two-pair port 2 LED bias
J16	1-2	P3	Two-pair port 3 LED bias
J15	1-2	P4	Two-pair port 4 LED bias
J26	1-2	P5	Four-pair port 1A LED bias
J25	1-2	P6	Four-pair port 1B LED bias
J14	1-2	P7	Four-pair port 2A LED bias
J13	1-2	P8	Four-pair port 2B LED bias
Daughterboard: TPS23880EVM-008			
J4	1-2;3-4;5-6;7-8	A1;A2;A3;A4	I2C A1-A4 address lines
J5	Open	NA	AUTO pin selection (resistors are not populated)

4 TPS23880EVM GUI Setup

4.1 TPS23880EVM GUI Installation

TI's TPS23880EVM GUI is used with the TPS23880EVM to control the port and provide real-time feedback on port telemetry. Download the TPS23880EVM GUI from the [TPS23880 product folder page](#) in the *Tools & software* section.

Follow the onscreen instructions to complete the installation. The TPS23880 GUI uses the USB2ANY as an interface between the PC USB port and the BOOST-PSEMTHR-007 J2 connector (I2C interface). Before starting the TPS23880 GUI, make sure the USB2ANY is properly connected to TPS23880EVM and the EVM is supplied with a 44- to 57-V power supply as [Figure 1](#) shows.

4.2 TPS23880EVM GUI Operation

Start the TPS23880EVM GUI by double clicking the GUI icon. A window similar to [Figure 3](#) comes up.

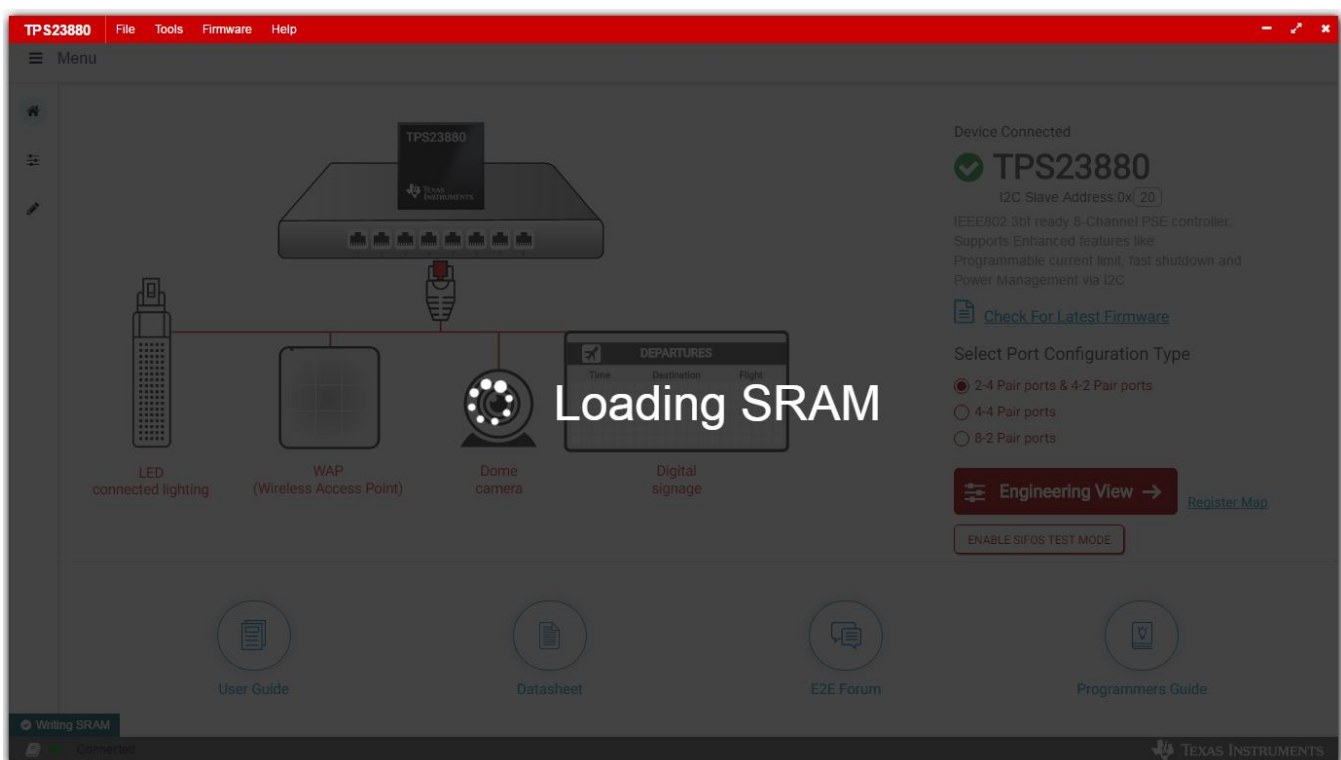

Figure 3. TPS23880EVM GUI SRAM Loading Window

After the GUI is opened, it automatically loads the default SRAM and parity check code to the TPS23880. The default device address in the GUI is set to 0x20 which matches the default configuration of the EVM (J4 on the daughter card is installed with jumpers). The GUI sets the TPS23880 in configuration B mode (see the *GENERAL MASK Register* section of the data sheet for details). The address can be programmed through the A1 to A4 pins and the I2C address setting in the GUI needs to match the hardware configuration. See the *Pin Status Register* section of the data sheet for details. The startup page contains links to the EVM user's guide, TPS23880 data sheet, E2E forum, and MSP430 reference code. Four popular PD end-equipment images are connected to the PSE switch. Links to the recommended PD device for each end equipment are also provided. Once *Device Connected* displays and port configuration type is selected, click *Engineering View*.

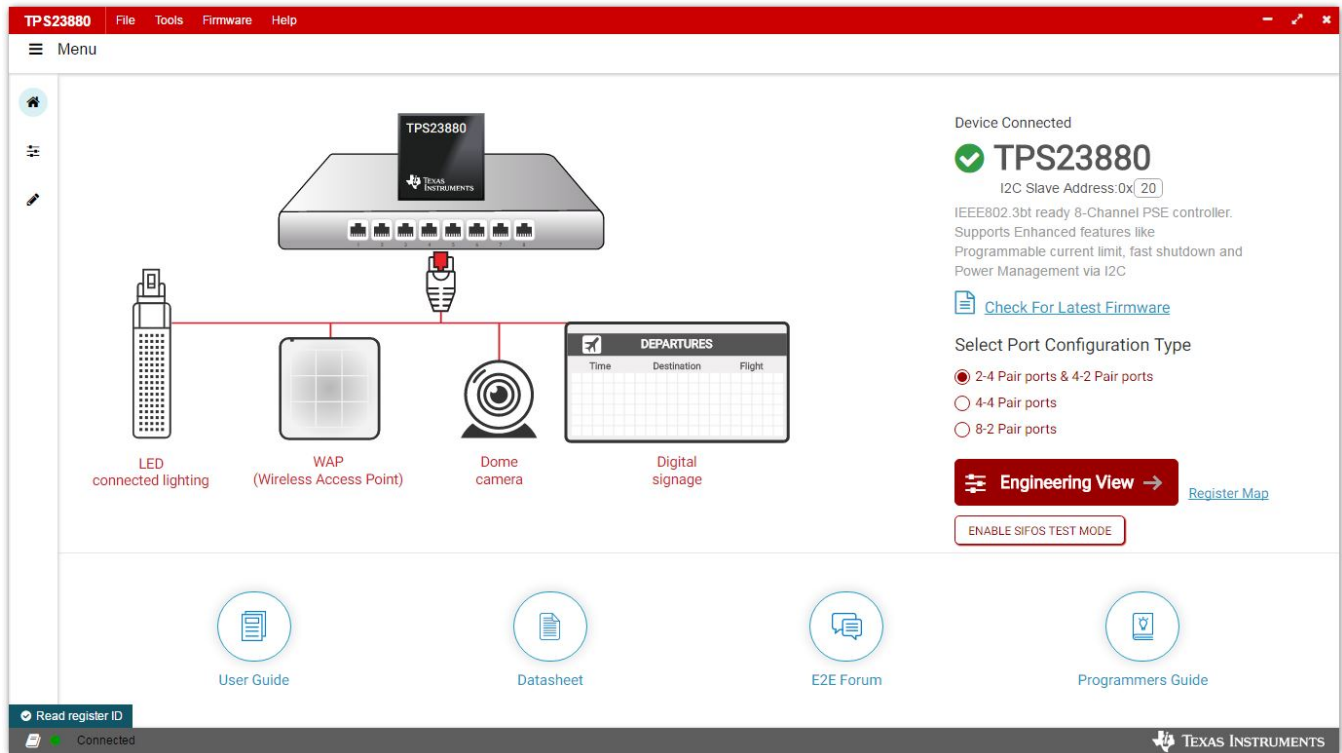

Figure 4. TPS23880EVM GUI Startup Window

On the page displayed in Figure 4, each port can be configured separately by clicking each RJ45 connector. By default, the TPS23880 is configured in OFF Mode. Each port can be configured by clicking the RJ45 icon. Clicking the *SET ALL PORTS TO STANDARD* button sets all port to standard configurations (configuring ports in Semi-Auto mode, enabling OSS, power policing, and DC disconnect). Clicking the *SET ALL PORTS TO AUTO MODE* button enables *Auto Mode* for all ports.

The status of each port is shown on the configuration and telemetry page. The configuration of the ports can also be edited on this page by clicking the RJ45 connector.

If the port is configured in *Auto Mode*, the port will turn on automatically by the PSE device after connecting a valid PD. If not configured in *Auto Mode*, a port enable command is required (*4P Enable* for 4 pair ports and *2P Enable* for 2 pair ports). The port can be turned on only when the PD has valid detection and classification results.

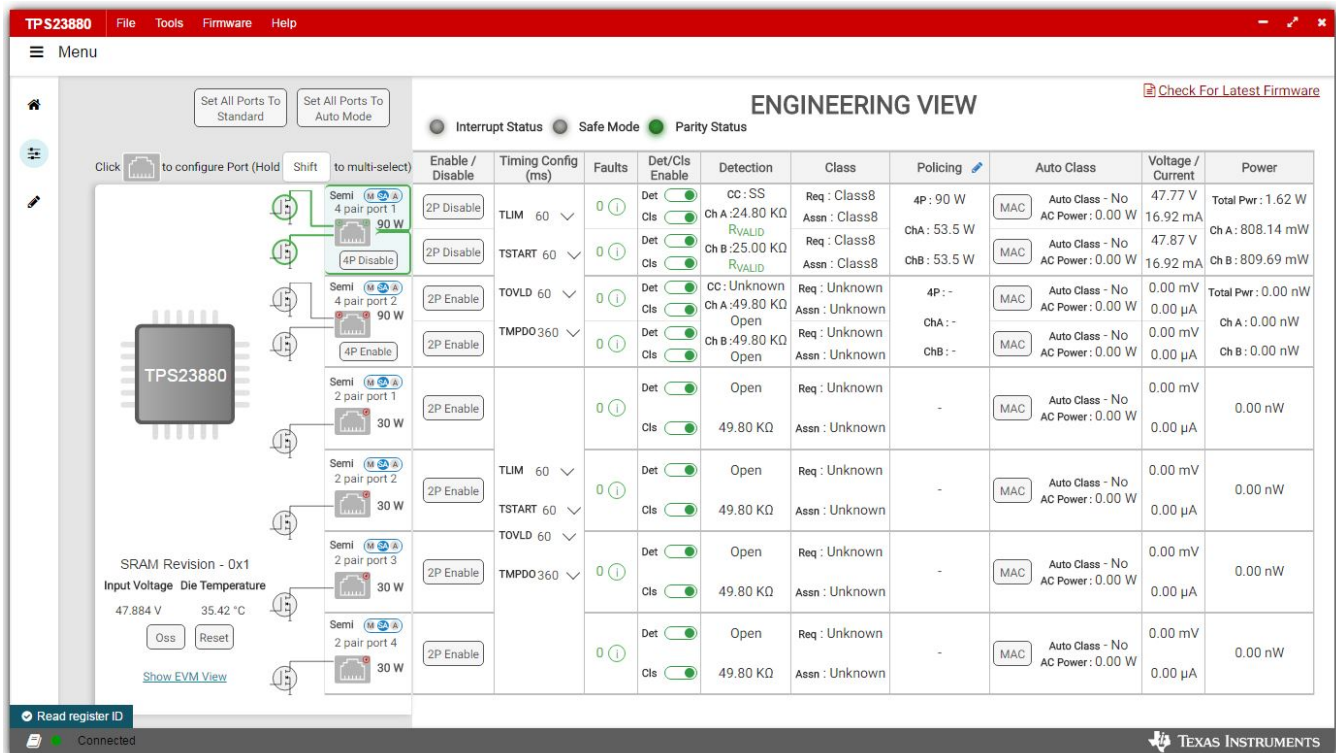

Figure 5. Device Configuration and Port Telemetry Page

The GUI also provides access to every register of the device in the register map.

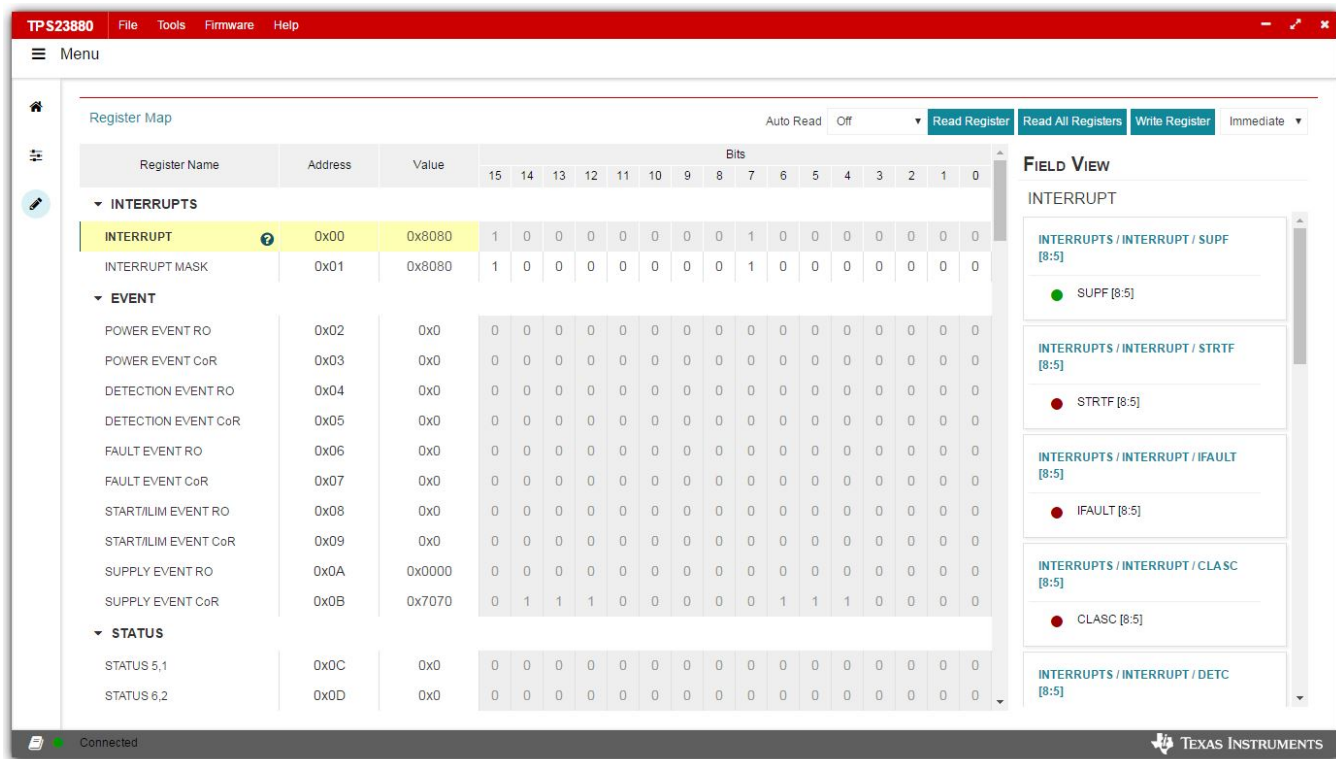

Figure 6. Register Map

If wanting to reload a different version of SRAM code, click "Firmware" on the left corner and select the SRAM code file. Once that's done, the new SRAM code will be loaded to TPS23880 device.

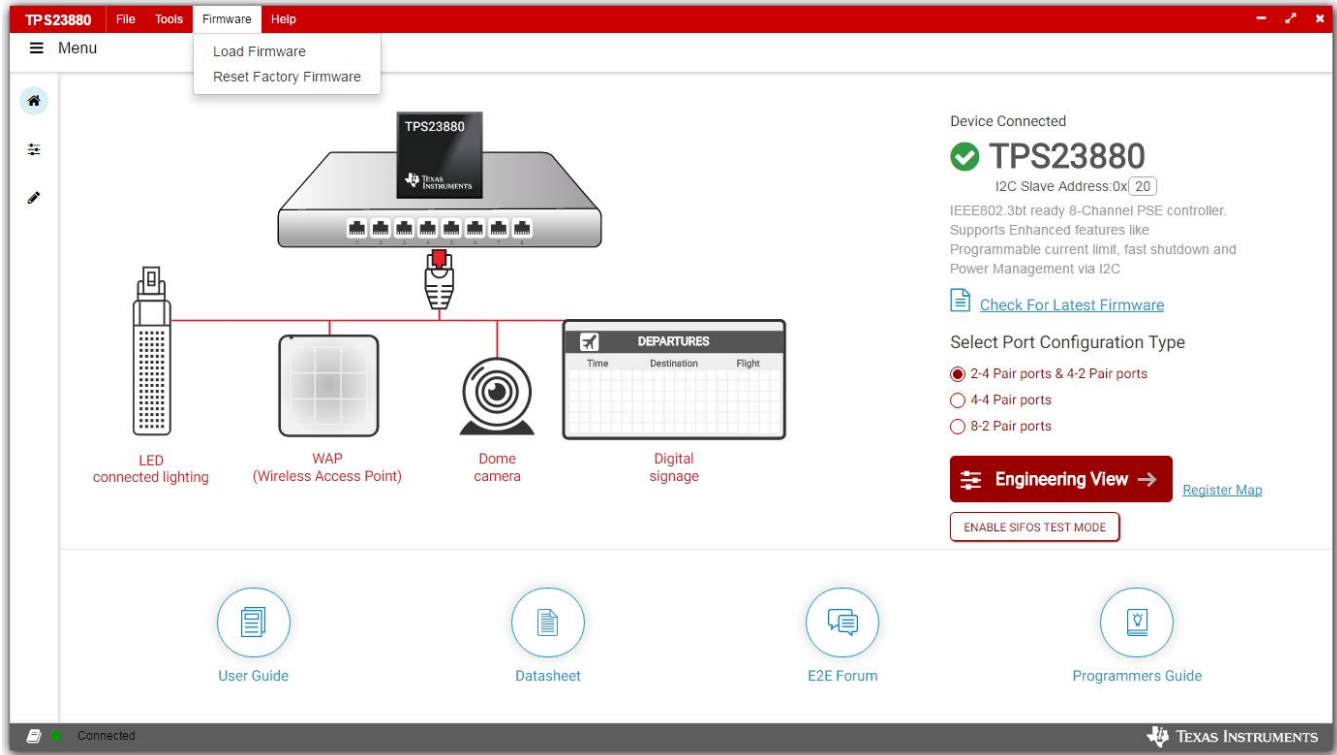

Figure 7. SRAM Code Load

4.3 MSP-EXP430FR5969 Details

The TPS23880EVM accepts the MSP-EXP430FR5969 evaluation module when the application requires management of the TPS23880 devices with an external controller.

1. Install MSP-EXP430FR5969 onto BOOST-PSEMTHR-007 and ensure that the USB2ANY ribbon cable is NOT installed into J2.
2. Connect the PC to the LaunchPad as shown in [Figure 2](#).
3. The source code was developed for the MSP430 LaunchPad Development Kit (MSP-EXP430GFR5969) using the Code Composer Studio™ (CCS) version 7.2.0 development environment. The target MSP430 can be programmed within this environment.
4. Once CCS is installed, use the basic set of instructions listed in [Section 4.3.1](#) to import, build, and run the project. CCS version 7.2.0 is used in the following examples. Note that a terminal program such as HyperTerminal or Teraterm is required to view the output from the EVM when it is running.

4.3.1 Basic CCS and Terminal Setup

Use the following steps for basic CCS and terminal setup:

1. Launch the CCS program on the PC: *Start* → *Texas Instruments* → *Code Composer Studio 7.2.0* → *Code Composer Studio 7.2.0*.
2. OK the workspace location and CCS starts.
3. Import the project: *Project* → *Import CCS Projects* (make sure you are in CCS Edit mode).
4. Navigate to the project location, then click the *Finish* button.
5. Build the project by clicking the hammer symbol.
6. Launch the debug session from CCS to activate the current project: *Run, Debug* (or F11).
7. Run the active project: *Run, Resume* (or play button, F8).
8. Determine the PC COM port connected to the LaunchPad by going into the *Device Manager Ports* (COM and LPT) section. Launch the terminal program.
9. Once the terminal program is properly connected to the LaunchPad running the PoE firmware, then text similar to the following image appears.

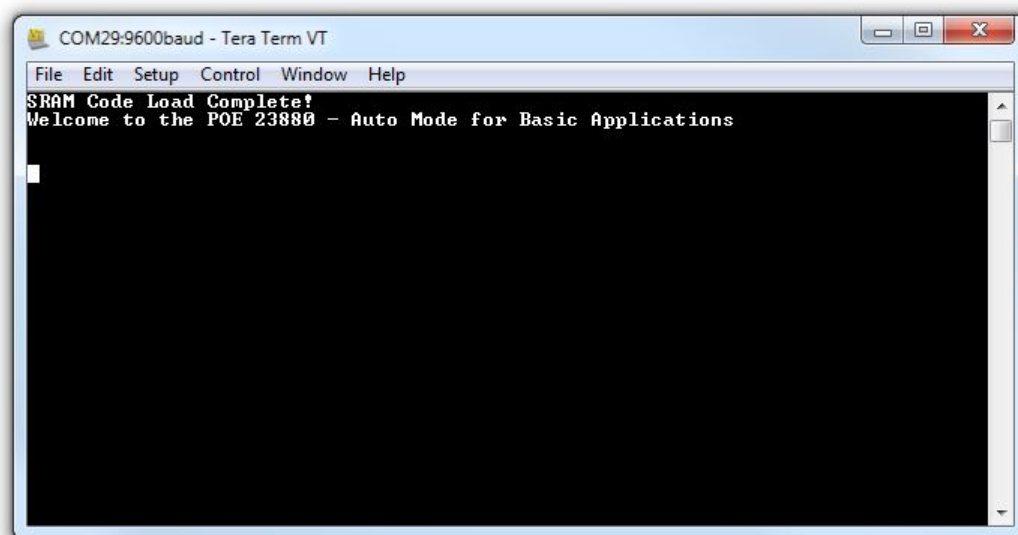

Figure 8. Program Started

- The TPS23880EVM is now waiting for a PD load to be installed. As ports are installed, the system automatically detects, classifies, and powers up the port as shown in [Figure 9](#). Port status is updated on the screen approximately every 10 seconds.

```

COM29:9600baud - Tera Term VT
File Edit Setup Control Window Help
Input Voltage: 49056mV
Device Temperature: 43 degrees C
Firmware Revision: F9
Channel 01: ON
Voltage: 49019mV Current: 15mA
Detection Status: RESISTANCE UALID Detection Resistance: 257810hm
Classification Status: Class 4
Channel 02: OFF
Detection Status: OPEN CIRCUIT
Classification Status: Unknown
Channel 03: OFF
Detection Status: OPEN CIRCUIT
Classification Status: Unknown
Channel 04: OFF
Detection Status: OPEN CIRCUIT
Classification Status: Unknown
Channel 05: ON
Voltage: 48642mV Current: 865mA
Detection Status: RESISTANCE UALID Detection Resistance: 246090hm
Classification Status: Class 8, 4 Pair Single Signature
Connection Check Status: 4-Pair Single Signature PD
Channel 06: ON
Voltage: 48598mV Current: 822mA
Detection Status: RESISTANCE UALID Detection Resistance: 248040hm
Classification Status: Class 8, 4 Pair Single Signature
Connection Check Status: 4-Pair Single Signature PD
Channel 07: ON
Voltage: 48960mV Current: 214mA
Detection Status: RESISTANCE UALID Detection Resistance: 248040hm
Classification Status: Class 4
Connection Check Status: 4-Pair Dual Signature PD
Channel 08: ON
Voltage: 48869mV Current: 209mA
Detection Status: RESISTANCE UALID Detection Resistance: 246090hm
Classification Status: Class 4
Connection Check Status: 4-Pair Dual Signature PD

---- Event Registers ---- Dev : 00 ----
0x99 0x1F 0x00 0x00 0x00

---- Port Status ----
0x44 0x06 0x06 0x06

---- Power Status ----
0x11

-----

---- Event Registers ---- Dev : 01 ----
0xFF 0xDF 0x0C 0x00 0x00

---- Port Status ----
0xB4 0xB4 0x44 0x44

---- Power Status ----
0xFF
    
```

Figure 9. Terminal Response With Connected Ports

4.4 MSP430 Reference Code

4.4.1 Overview

There are two versions of MSP430 reference code published on ti.com. One is for basic applications and the other is focused on multi-port power management applications. The reference code for multi-port power management applications will be discussed in detail since it has more flexibility and complexity.

The system software supports the following features:

- IEEE802.3bt (draft) PoE specification
- Device detection, connection check, and classification
- Automatic power on (standard 2-pair and 4-pair PDs)
- DC disconnect
- Port telemetry updates
- Multi-port power management

The reference code can support PSE systems with up to 48 ports. It keeps track of all system-level parameters as well as port-level parameters for each TPS23880 device within the system.

The MSP430 communicates with the PC through UART, reporting the parameter and status of the port.

CAUTION

The parity programming is not available for current version of reference code.

4.4.2 Auto Mode

Auto mode operation is demonstrated in the MSP430 reference code and [Figure 10](#) shows the flow chart. Basically, after configuration, the TPS23880 handles port detection, classification, turn on, and faults by itself and there is no control needed from the host.

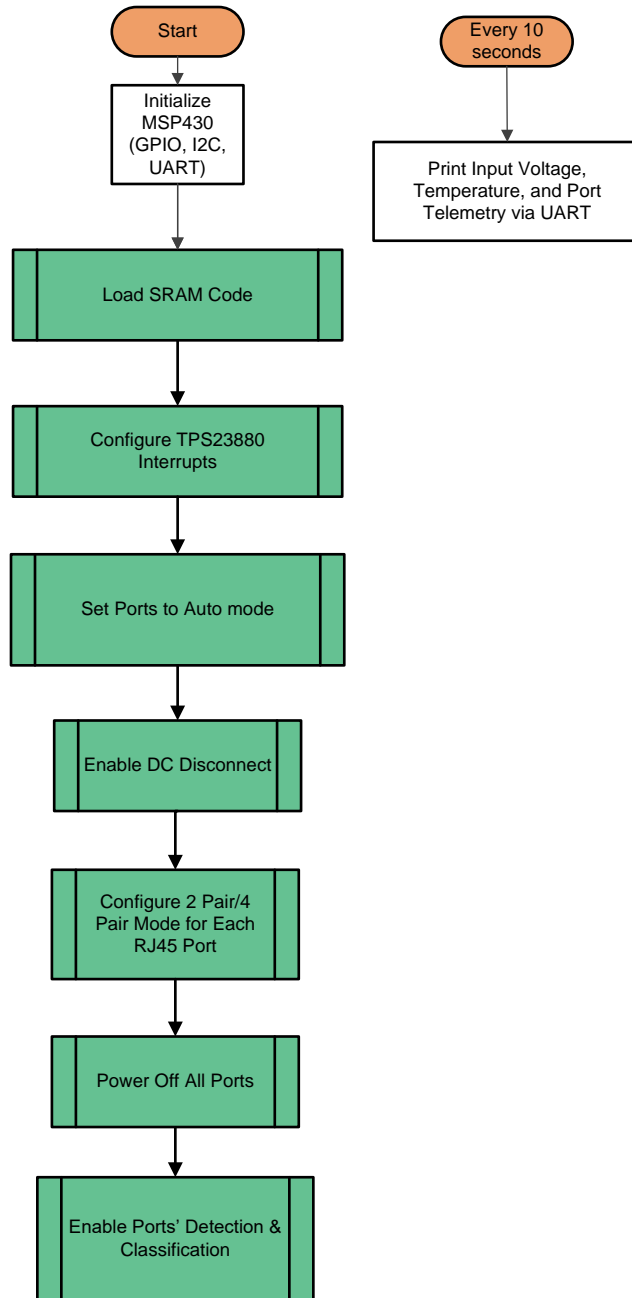

Figure 10. Auto Mode System Software Structure

4.4.3 Semi Auto Mode

Operation The Semi Auto Mode reference code is interrupt based. When MSP430 receives an interrupt from PSE's INT pin, the code checks interrupt register and event registers to proceed with actions accordingly. The flowchart of semi auto mode code is shown as below.

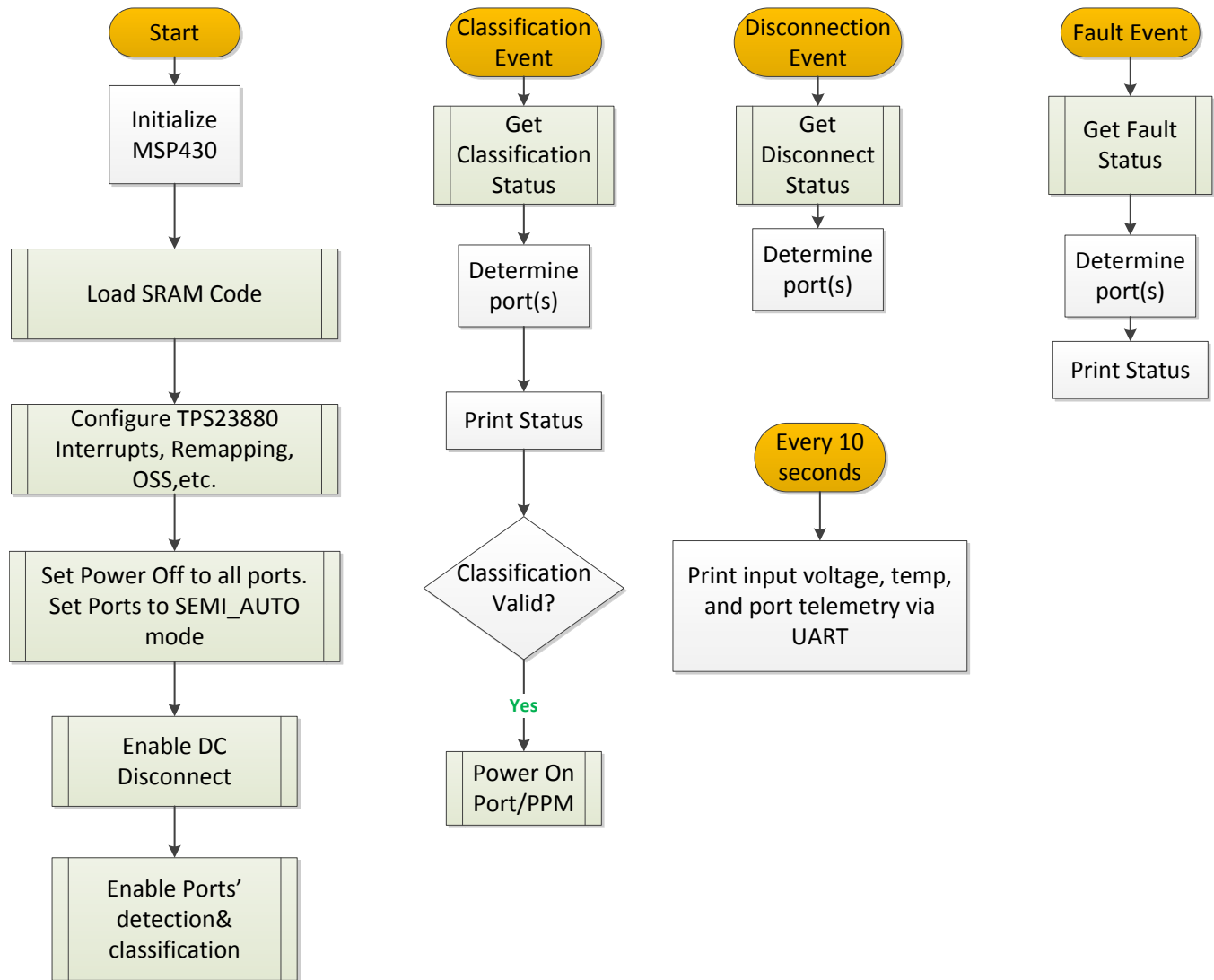

Figure 11. Semi Auto Mode System Software Structure

4.4.4 Multi-Port Power Management Module

Multi-Port Power Management methods are used to manage the distribution and prioritization of PDs. Power Management itself is not defined by the IEEE specification. Instead, it is a policy that takes advantage of the POE specification as it defines such terms as port and system power. The goals of Multi-Port Power Management in a POE enabled system are two-fold:

- Power as many PDs as possible
- Limit power cycling of PDs

In many systems, the maximum system power available limits the total number of ports that may be powered. For example, each PD can draw a maximum of 30W, and a 48-port system can draw more than 1440W total system power. If the maximum system power available is less than 1440W then Power Management becomes necessary so that the available system power may be used in the most efficient manner while meeting the goals.

4.4.4.1 Definitions and Formulas

Table 6 defines terms used in the Power Management algorithm.

Table 6. Terminology

TERM	DEFINITION
sysPower	The current total power consumed by PDs
portPowerEstimate	The estimated power the current port(finished detection and classification) is going to consume
lowestPrioPort	The lowest priority port among all turned on ports
powerOffPort	Port will be powered off
powerOnPort	Port will be turned on

4.4.4.2 State Definitions

The Power Management algorithm operates as a state machine, whereby the algorithm is a certain state at any given point in time. Table 7 shows the state definitions for the algorithm.

Table 7. State Definitions

STATE	DEFINITION
PM_CHECK	Calculate existing ON ports' total power, get current port estimate power, compare total power + port estimate power and Power budget
PM_POWERUP	Power up current port
PM_OVERLIMIT	Power demand has exceeded the power budget. Calculate whether the remaining power is enough to turn on current port after turning off all lower priority ports
PM_POWERDOWN	Power down the lowest priority port. Entered from PM_OVERLIMIT

4.4.4.3 Function Definitions

The power management function is called after a valid classification is performed. It includes the functions below to implement the algorithm.

Table 8. Function Definitions

FUNCTION	DEFINITION
uint32_t PM_calSysPower(void)	Calculate current total power consumed by PDs
uint8_t PM_getActLowestPrioPort(void)	Find lowest priority port among all turned on ports
uint32_t PM_getPowerofPortsHigherPriority(uint8_t PM_sysPortNumber)	Calculate total power of ports that have the same or higher priority
uint32_t PM_getRequestPower(uint8_t PM_sysPortNumber)	Get estimate power of current port(finished detection and classification) is going to consume based on classification results
void PM_powerManagement(uint8_t PM_sysPortNumber)	Power management function called in main function
void PM_monitorSysPower(void) Note: running in background, timer interrupt triggered	Real-time check if current total power consumed by PDs exceeds power budget (to prevent load step change on any ports).

4.4.4.4 User Configurable Parameters

The PPM module gives user some flexibility to configure. [Table 9](#) shows the user configurable parameters.

Table 9. User Configurable Parameters

TERM	DEFINITION	LOCATION
#define PM_EN	Enable PPM feature. Enable=1, disable=0.	power_manage.h
#define PM_POWER_BUDGET	Total system power budget. Unit: mW	power_manage.h
#define NUM_OF_TPS2388x	Total number of TPS23880 in the system	system_init.h
#define PM_POWER_MONITOR_TIMER	The timer that host monitor the actual system power	system_init.h
#define PM_DETECT_CLASS_RESTART_TIMER	The timer that host restart detection/ classification of the ports which are turned off	system_init.h
uint8_t i2cAddList[]	I2C address of TPS23880	system_init.c
uint8_t PM_setPriority[]	The port priority setting of each port	system_init.c
TPS238x_2P_Power_Allocation_t tps2388x_PA_2P[]	Power allocation for 2 pair ports	system_init.c
TPS238x_4P_Power_Allocation_t tps2388x_PA_4P[]	Power allocation for 4 pair ports	system_init.c

4.4.4.5 Design Flow

The Power Management algorithm is shown in below figure in the form of a flow chart.

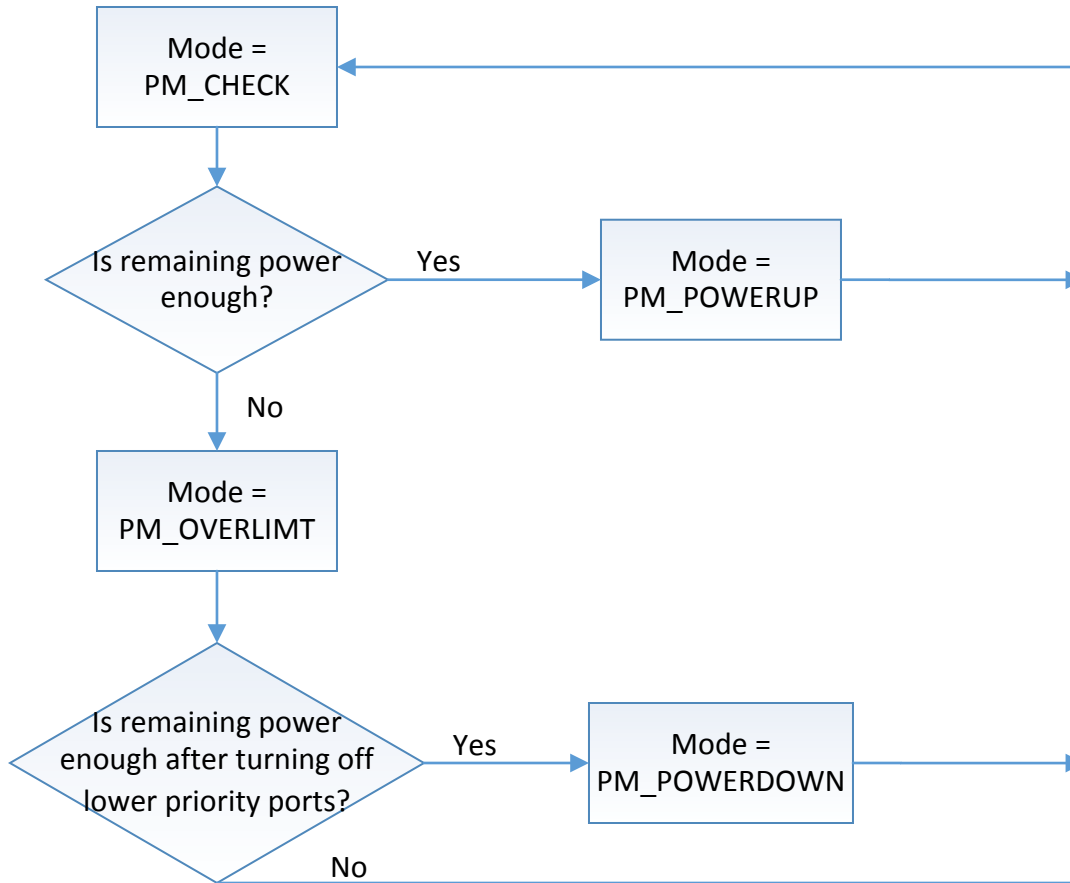

Figure 12. Power on Decision Flow Chart

Real-time system power monitor to protect the system when step change happening on any ports. (100 ms timer triggered):

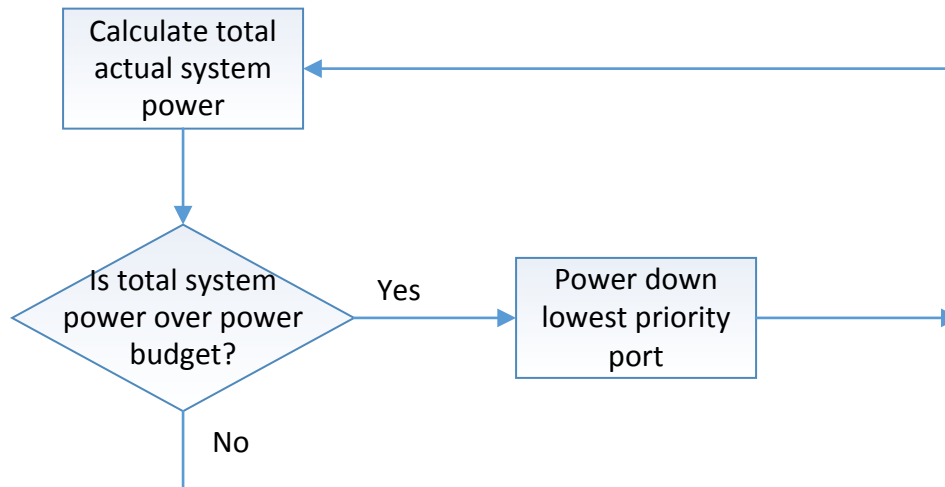

Figure 13. System Power Monitor Flow Chart

4.4.4.6 Pseudo-Code

The Power Management algorithm can also be represented by the following pseudo-code.

```
//This part is inserted after each port's successful classification

if (Mode == Check)
{
    Get RequesPortPower;

    Calculate SystemPower;

    if (SystemPower + RequesPortPower > PowerBudget)
    {
        Mode = OverLimit;
    }
    else
    {
        Mode = PowerUp;
    }
}

if (Mode == OverLimit)
{
    //If the remaining power is enough to turn on current port after powering down all ports that
    //have lower priority,
    //then turn off the lowest priority port; otherwise, wait for next cycle

    if (PowerofHigherPriorityPorts + RequesPortPower <= PowerBudget)
    {
        Mode = PowerDown;
    }
    else
    {
        Mode = Check;
    }
}

if (Mode == PowerDown)
{
    Power down the port with lowest priority;
```

```

Restart port's detection/classification;

Mode = Check;
}

if (Mode == PowerUp)
{
    Power on the port which is requesting power;
    Mode = Update;
}

//This part is inserted in a timer(every 100 ms) intrerrupt

if (system power > PowerBudget)
{
    Turn off the port with lowest priority;
    Restart port's detection/classification;
}

```

5 EVM Schematic, Layout Guidelines and PCB Assembly, Layer Plots

This section contains the TPS23880EVM schematic, layout guidelines, and printed-circuit board (PCB) assembly and layer plots.

5.1 Schematic

[Figure 14](#) through [Figure 16](#) illustrate the TPS23880EVM (daughter card+motherboard) schematics.

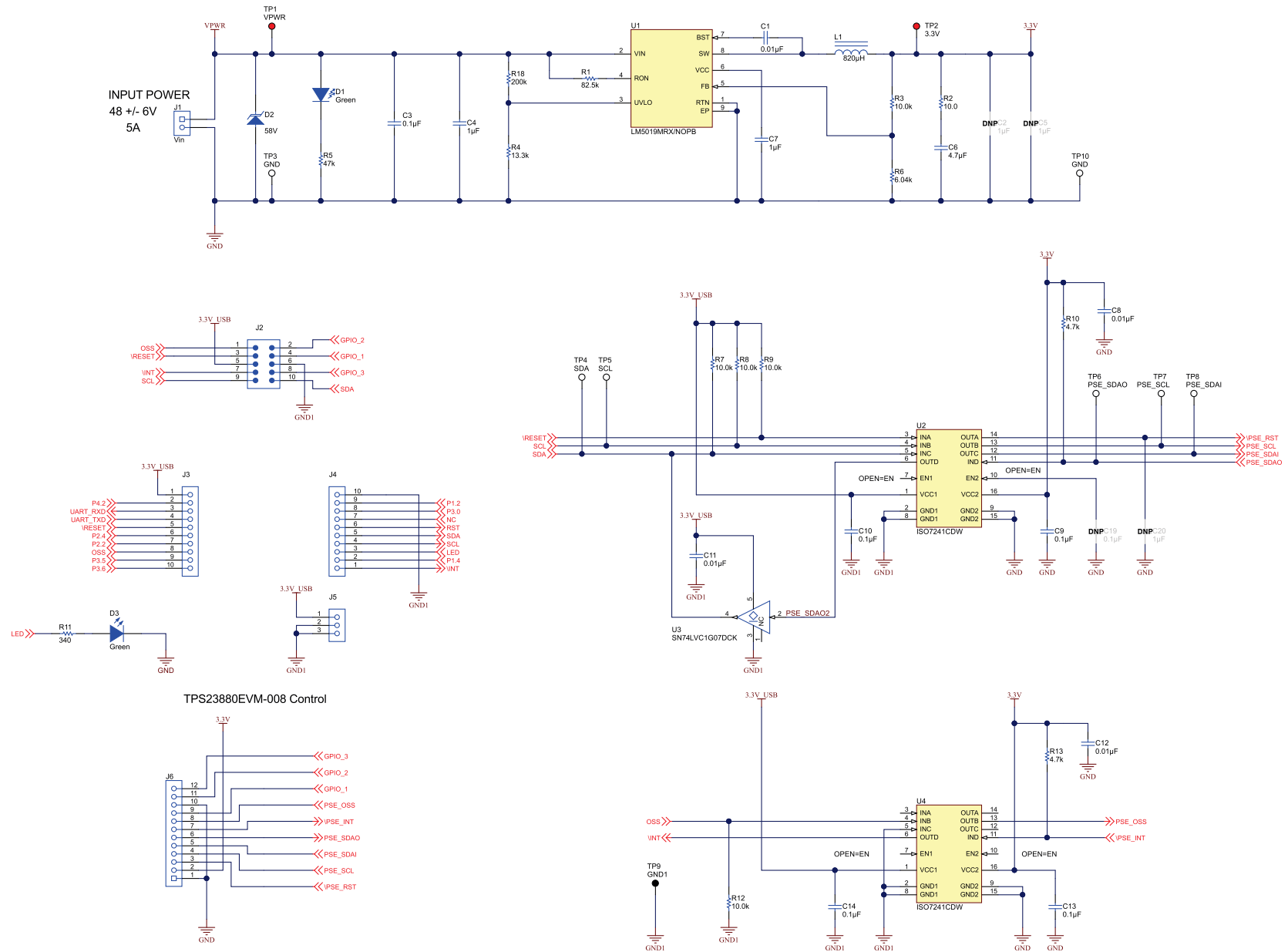
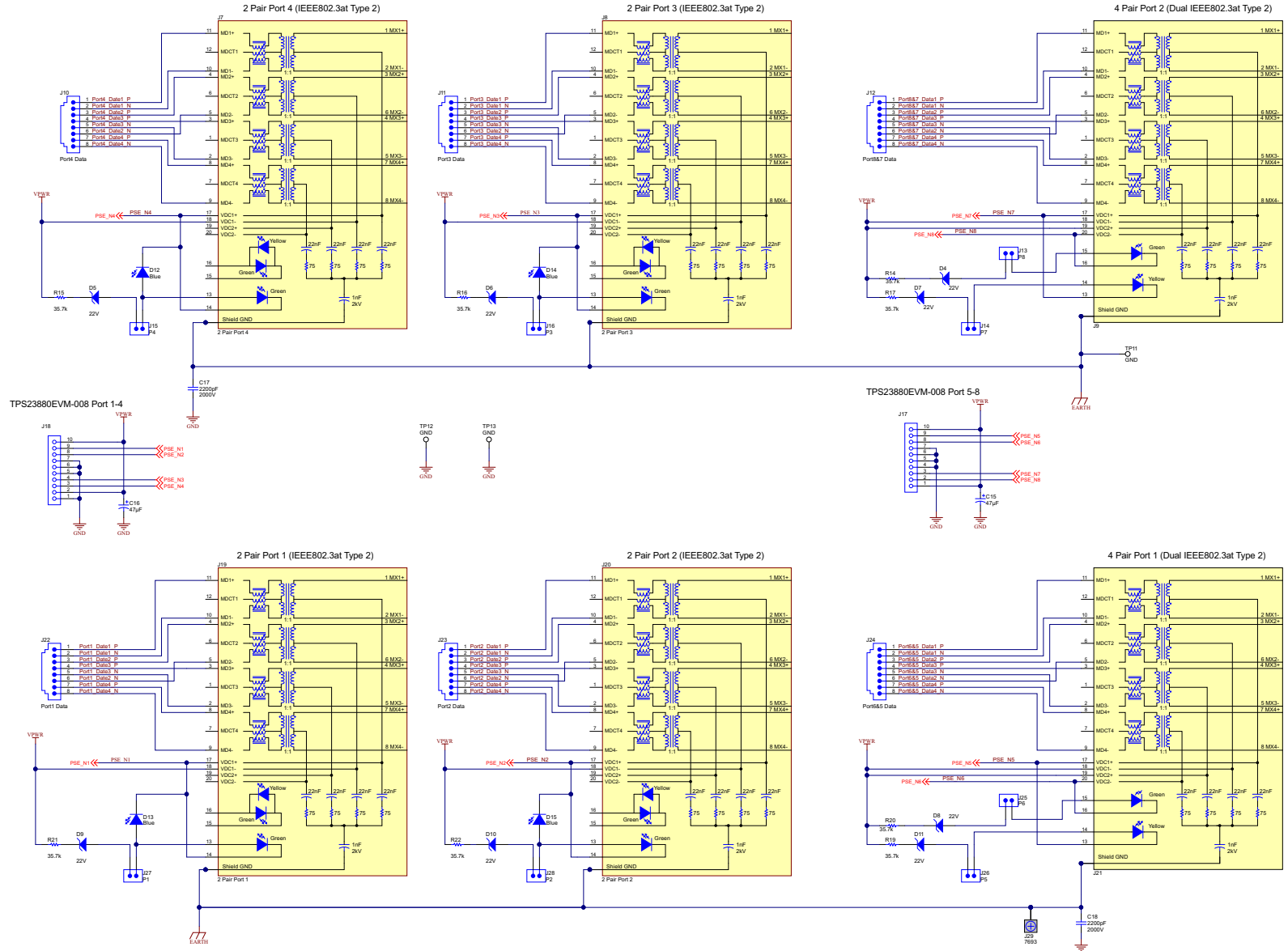

Figure 14. BOOST-PSEMTHR-007 (Motherboard) Schematic: Control



Copyright © 2018, Texas Instruments Incorporated

Figure 15. BOOST-PSEMTHR-007 (Motherboard) Schematic: Power Ports

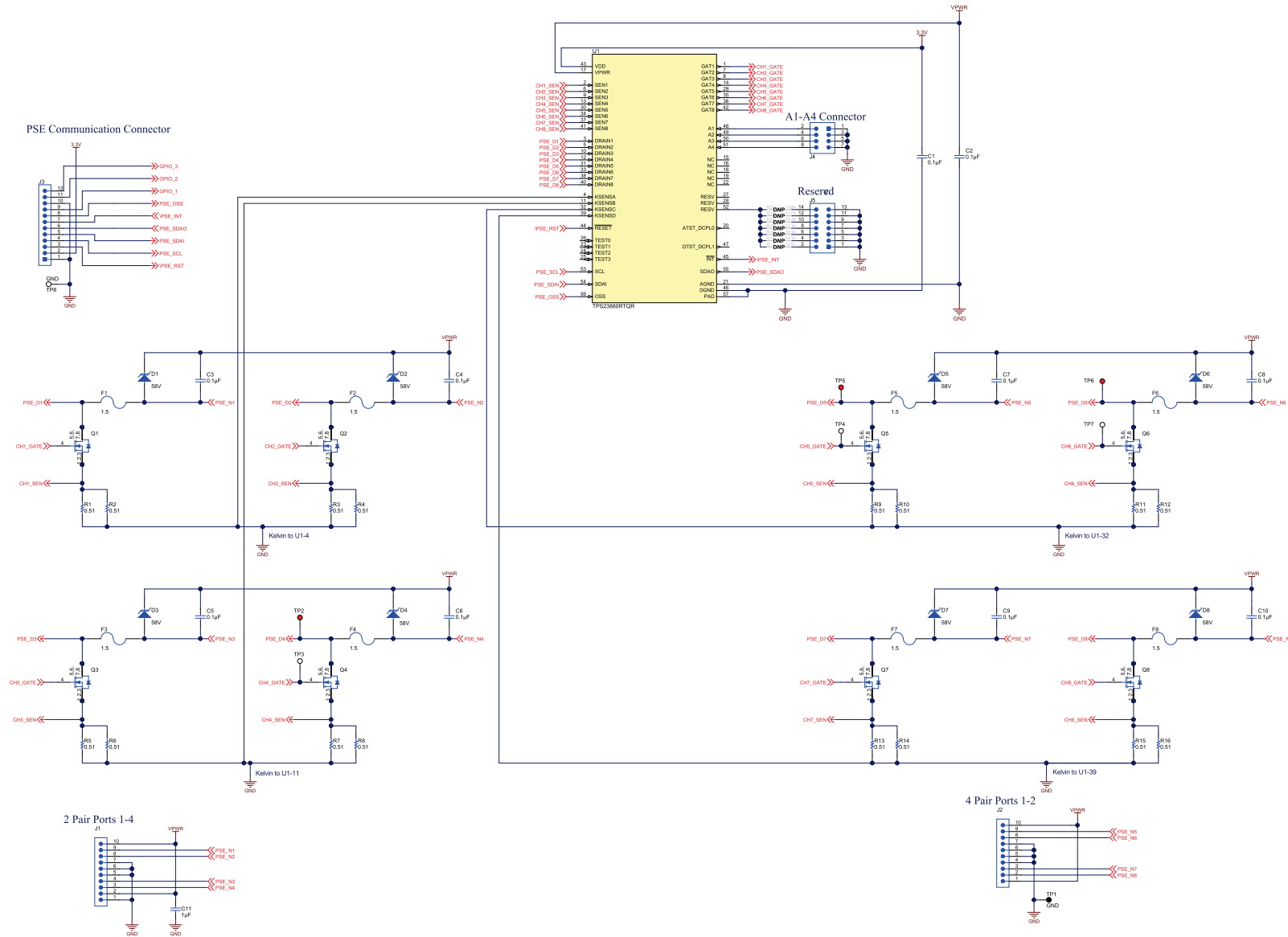

Figure 16. TPS23880EVM-008 (Daughterboard) Schematic

5.2 Layout Guidelines

5.2.1 Supply Voltage Decoupling

Provide power supply pin bypass to the TPS23880 device as follows:

- 0.1 μ F, 100 V, X7R ceramic at pin 28 (VPWR)
- 0.1 μ F, 50 V, X7R ceramic at pin 1 (VDD)

5.2.2 Port Current Kelvin Sensing

KSENSA is shared between SEN1 and SEN2, while KSENSB is shared between SEN3 and SEN4. In order to optimize the accuracy of the measurement, the PCB layout must be done carefully to minimize the impact of PCB trace resistance. Refer to [Figure 23](#) as an example.

5.2.3 Ground Plane Spacing and Isolation (GND, GND1, and EARTH nets)

Appropriate spacing should be provided between the GND, GND1, and EARTH nets as shown in [Figure 19](#).

5.3 PCB Drawings

[Figure 17](#) through [Figure 25](#) show the PCB layouts and assemblies for this EVM.

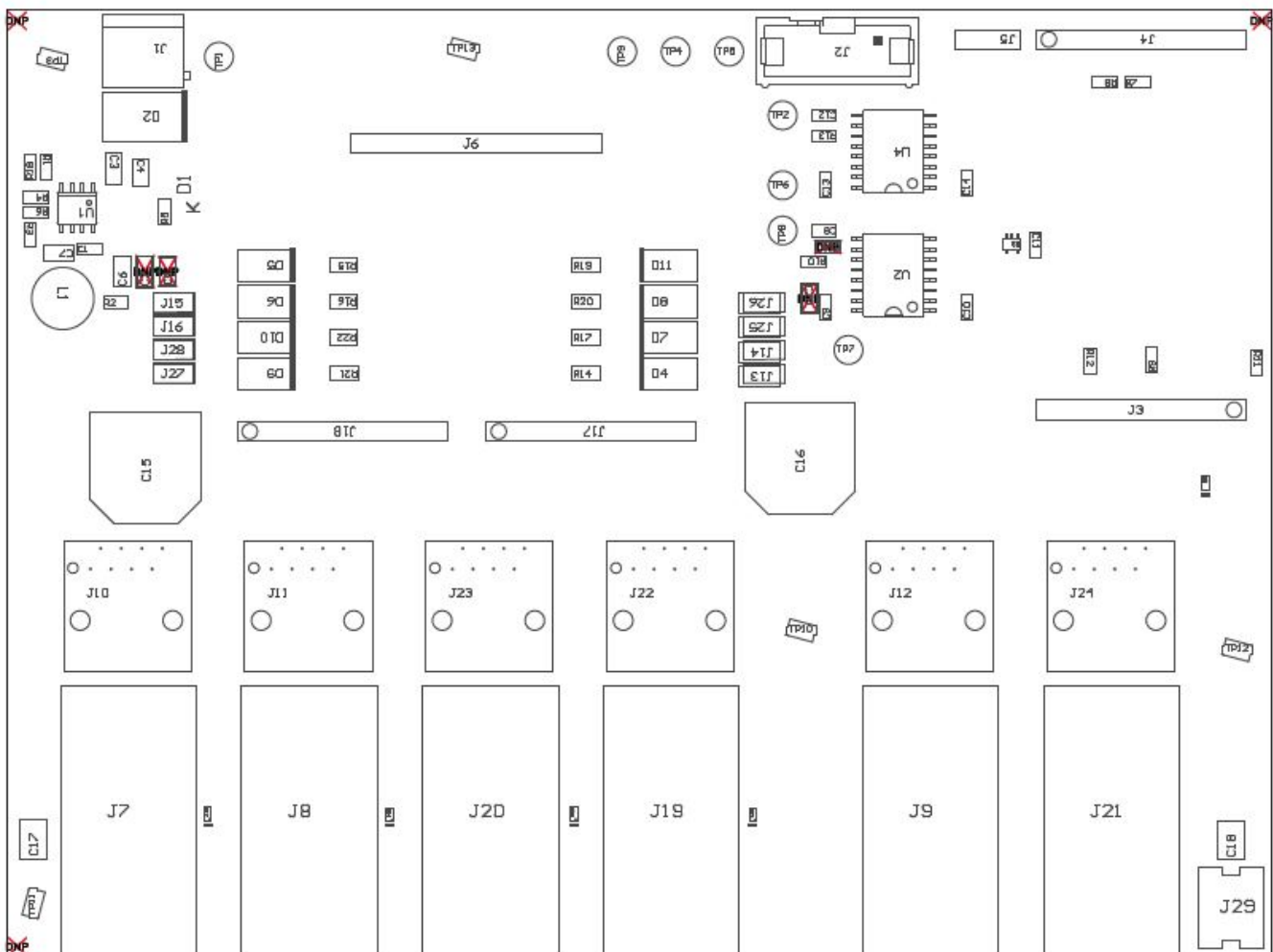

Figure 17. BOOST-PSEMTHR-007 (Motherboard) Top Side Assembly

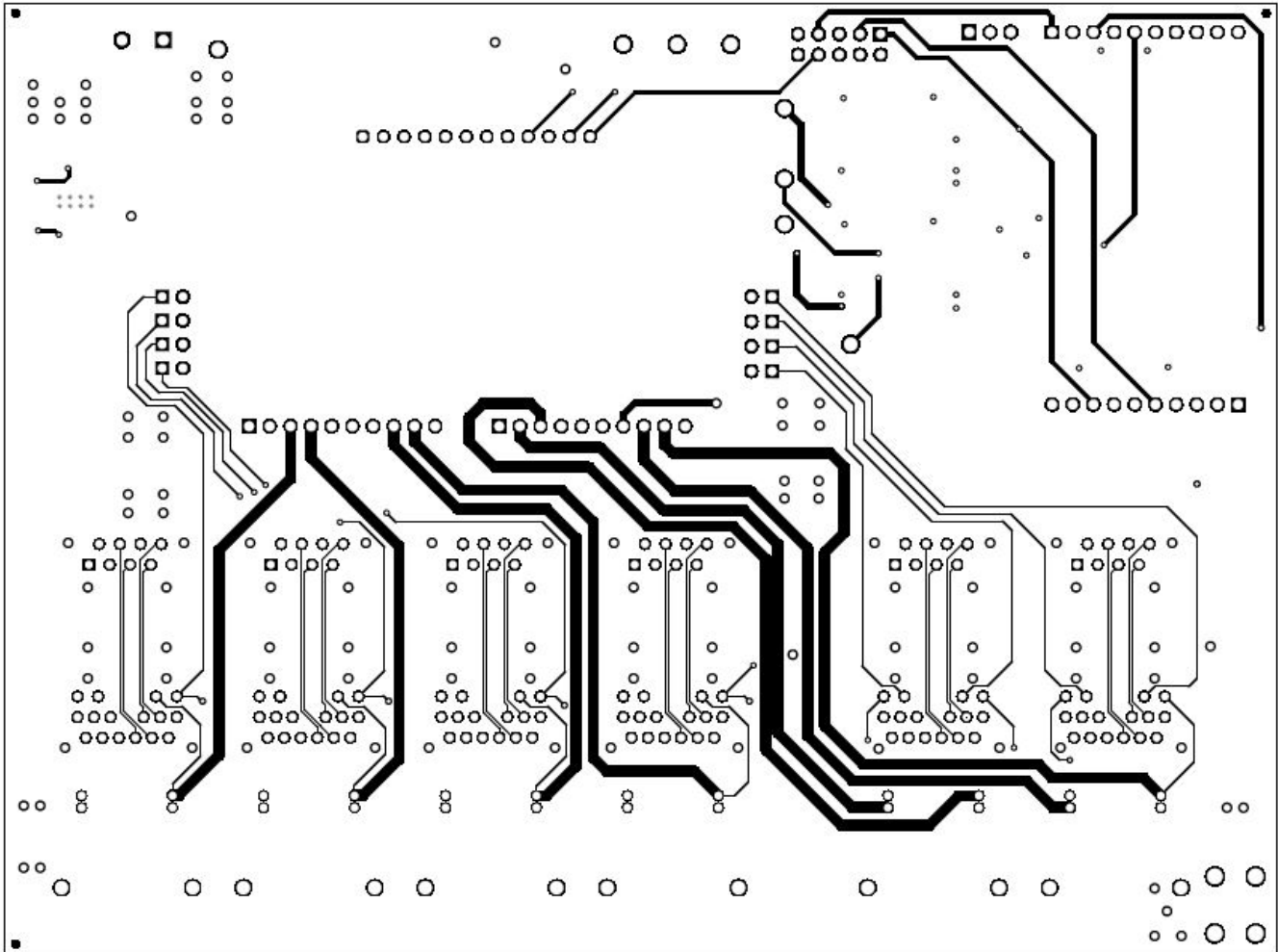

Figure 18. BOOST-PSEMTHR-007 (Motherboard) Top Side Routing

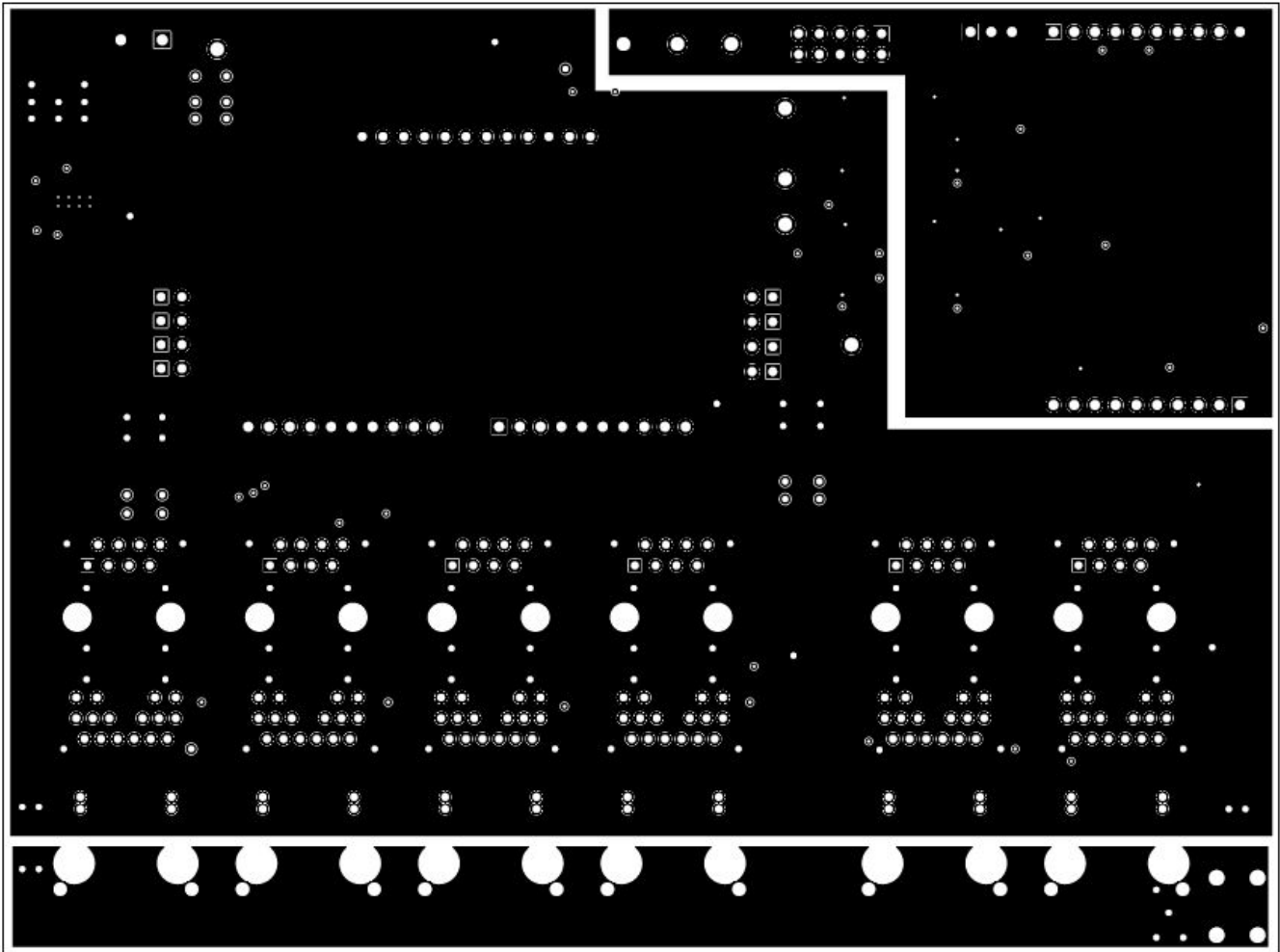

Figure 19. BOOST-PSEMTHR-007 (Motherboard) Layer 2 Routing

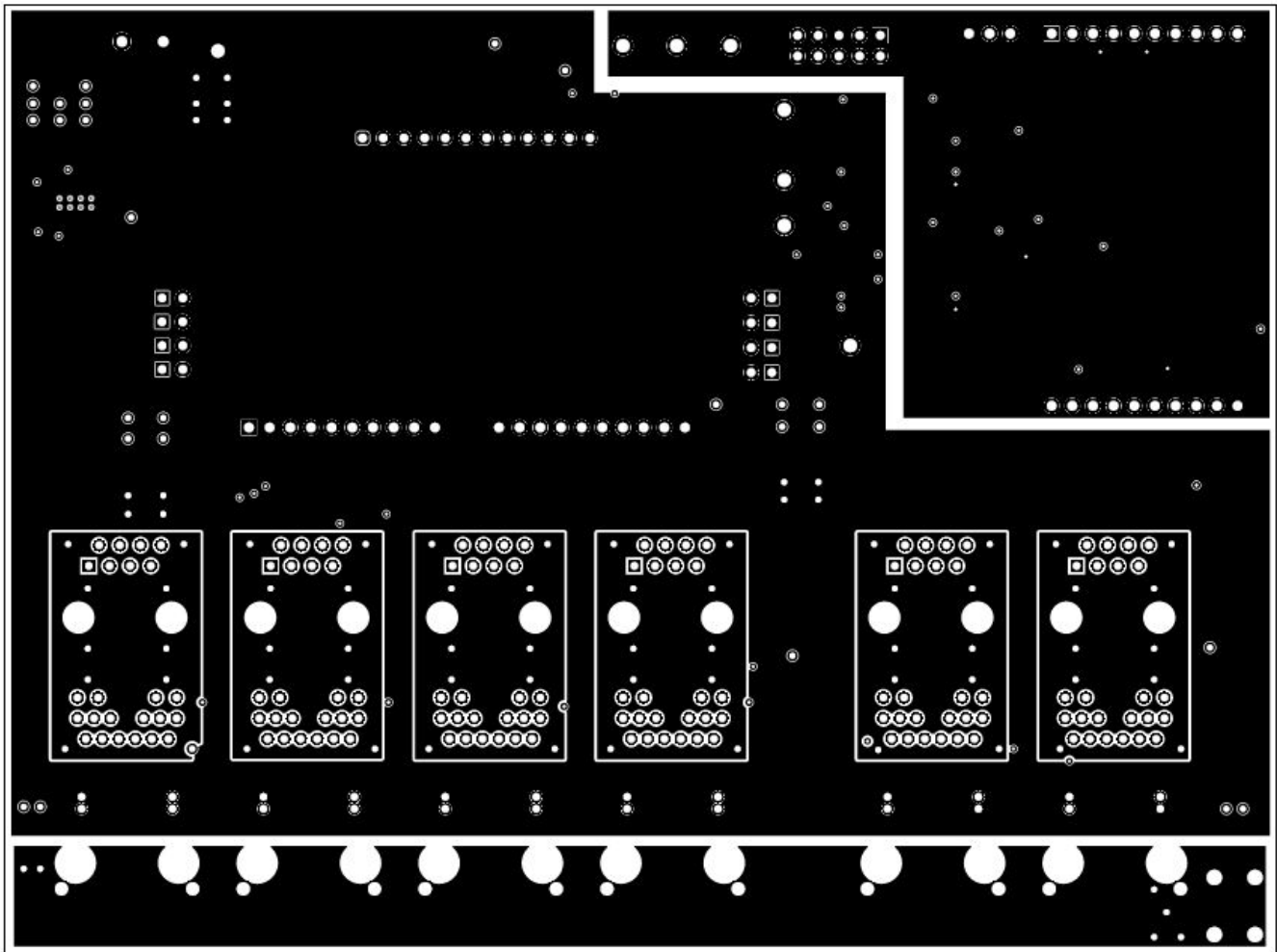

Figure 20. BOOST-PSEMTHR-007 (Motherboard) Layer 3 Routing

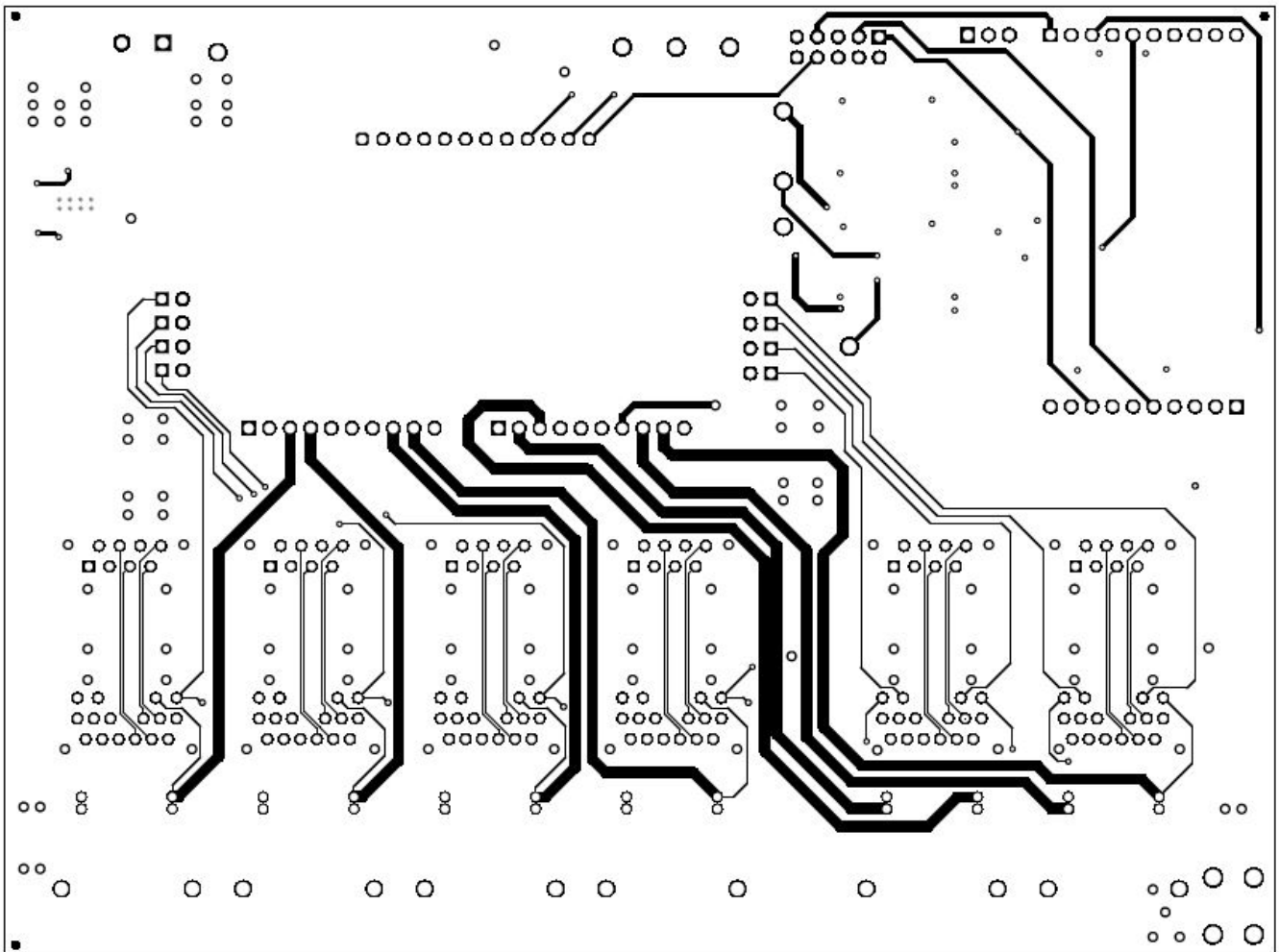

Figure 21. BOOST-PSEMTHR-007 (Motherboard) Bottom Side Routing

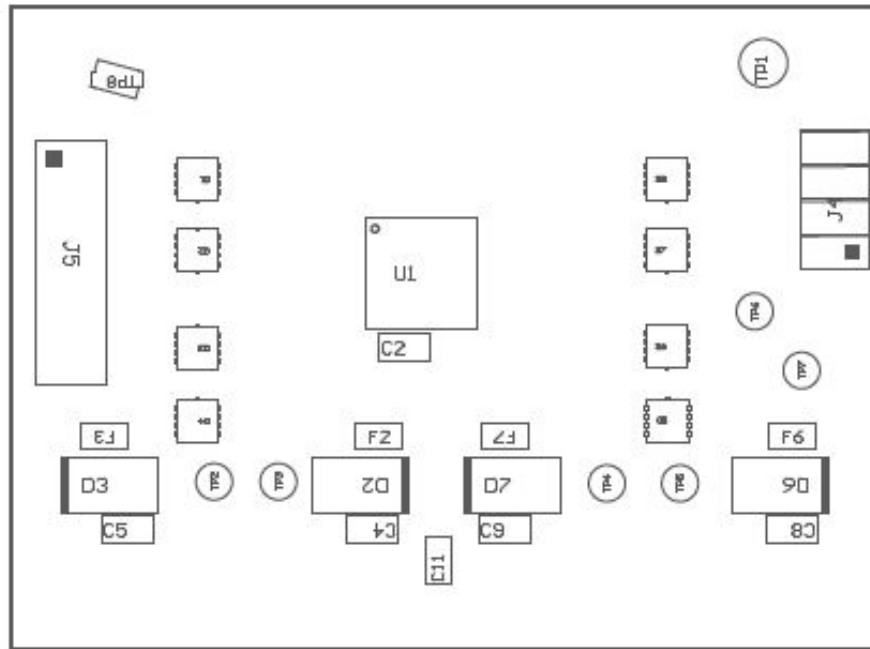

Figure 22. TPS23880EVM-008 (Daughterboard) Top Side Assembly

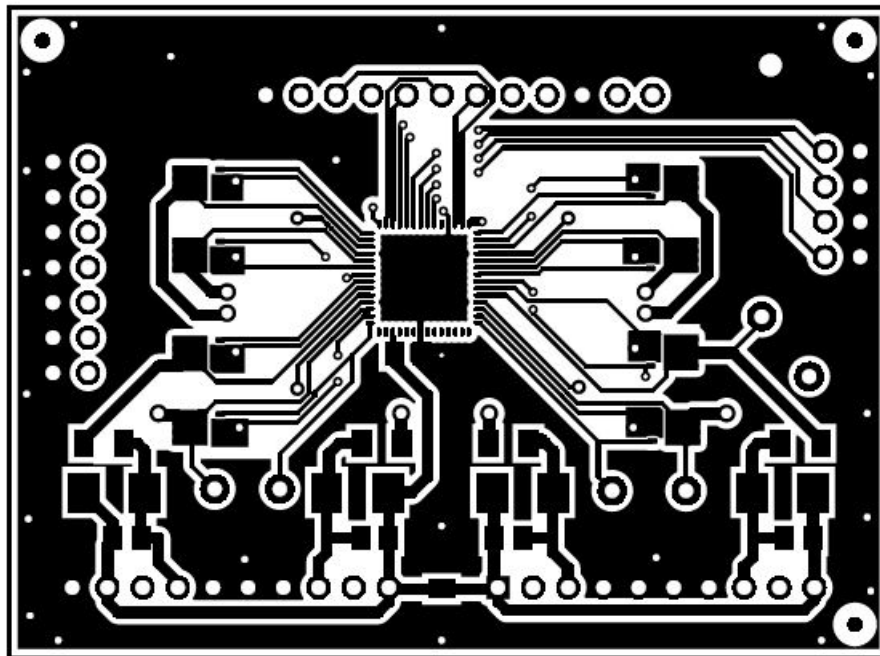

Figure 23. TPS23880EVM-008 (Daughterboard) Top Side Routing

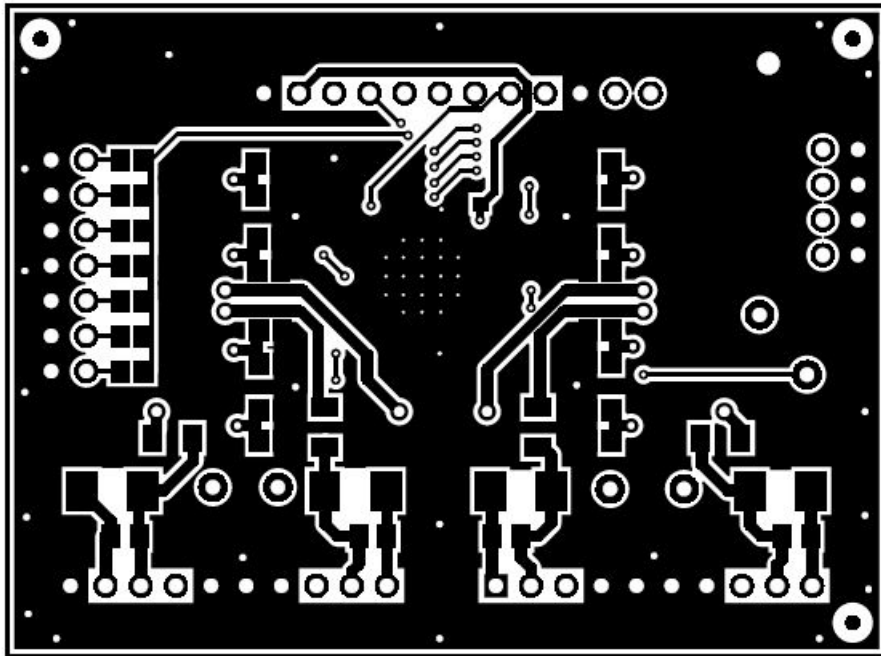

Figure 24. TPS23880EVM-008 (Daughterboard) Bottom Side Routing

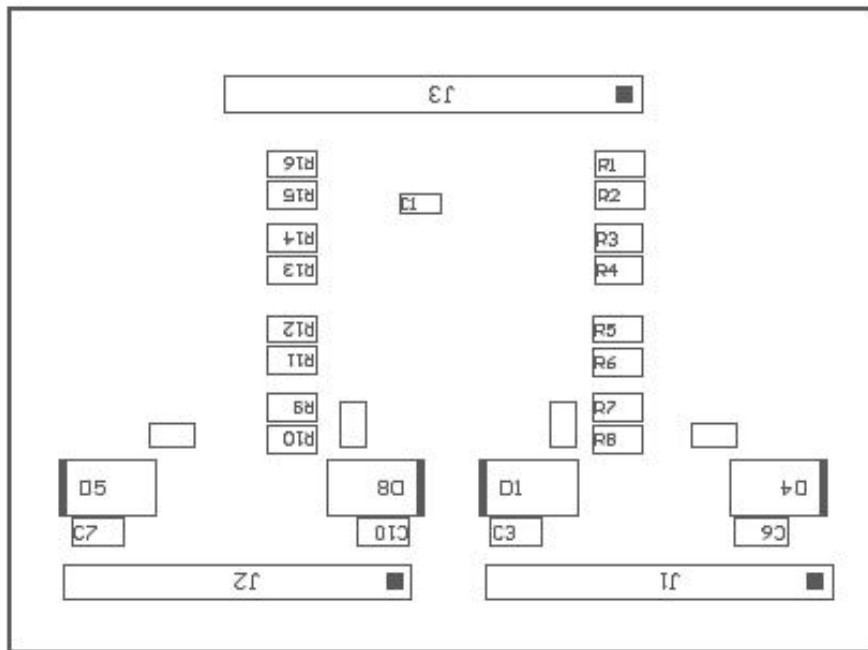

Figure 25. TPS23880EVM-008 (Daughterboard) Bottom Side Assembly

6 Bill of Materials

The BOMs for the BOOST-PSEMTHR-007 and TPS23880EVM-008 are listed in [Table 10](#) and [Table 11](#), respectively.

Table 10. BOOST-PSEMTHR-007 Bill of Materials⁽¹⁾

Designator	QTY	Value	Description	Package Reference	Part Number	Manufacturer	Alternate Part Number	Alternate Manufacturer
IPCB	1		Printed Circuit Board		PSIL007	Any		
C1, C8, C11, C12	4	0.01uF	CAP, CERM, 0.01uF, 100V, ±10%, X7R, 0603	0603	06031C103KAT2A	AVX	885012206114	Würth Elektronik
C3	1	0.1uF	CAP, CERM, 0.1uF, 100V, ±10%, X7R, 0805	0805	C2012X7R2A104K	TDK	885012207128	Würth Elektronik
C4	1	1uF	CAP, CERM, 1uF, 100V, ±10%, X7R, 1206	1206	GRM31CR72A105KA01L	Murata		
C6	1	4.7uF	CAP, CERM, 4.7 uF, 10 V, ±10%, X5R, 0805	0805	C0805C475K8PACTU	Kemet	885012107009	Würth Elektronik
C7	1	1uF	CAP, CERM, 1uF, 10V, ±10%, X7R, 0805	0805	0805ZC105KAT2A	AVX	885012207022	Würth Elektronik
C9, C10, C13, C14	4	0.1uF	CAP, CERM, 0.1uF, 50V, ±10%, X7R, 0603	0603	06035C104KAT2A	AVX	885012206095	Würth Elektronik
C15, C16	2	47uF	CAP, AL, 47uF, 100V, ±20%, 0.32 ohm, SMD	SMT Radial H13	EEV-FK2A470Q	Panasonic	865080862008	Würth Elektronik
C17, C18	2	2200pF	CAP, CERM, 2200pF, 2000V, ±10%, X7R, 1812	1812	C4532X7R3D222K	TDK	885342211007	Würth Elektronik
D1	1	Green	LED, Green, SMD	Power TOPLED w/lens	LT E63C-CADB-35-1-Z	OSRAM	150141GS73100	Würth Elektronik
D2	1	58V	Diode, TVS, Uni, 58V, 1500W, SMC	SMC	SMCJ58A-13-F	Diodes Inc.		
D3	1	Green	LED, Green, SMD	1.6x0.8x0.8mm	LTST-C190KGKT	Lite-On		
D4, D5, D6, D7, D8, D9, D10, D11	8	22V	Diode, Zener, 22V, 550mW, SMB	SMB	1SMB5933BT3G	ON Semiconductor		
D12, D13, D14, D15	4	Blue	LED, Blue, SMD	BLUE 0603 LED	LB Q39G-L2N2-35-1	OSRAM	150060BS75000, 150060BS75000, 150060BS75000 , 150060BS75000	Würth Elektronik
H1, H2, H3, H4, H5, H6, H7, H8, H9	9		Bumpon, Cylindrical, 0.312 X 0.200, Black	Black Bumpon	SJ61A1	3M		
J1	1		Terminal Block, 5.08 mm, 2x1, Brass, TH	2x1 5.08 mm Terminal Block	ED120/2DS	On-Shore Technology	691236510002	Würth Elektronik
J2	1		Header (shrouded), 100mil, 5x2, High-Temperature, Gold, TH	5x2 Shrouded header	N2510-6002-RB	3M	61201021621	Würth Elektronik
J3, J4, J17, J18	4		Connector, Receptacle, 100mil, 10x1, Gold plated, TH	HEADER, RECEPTACLE, 100mil, 10x1	SSW-110-01-G-S	Samtec, Inc.	61301011821	Würth Elektronik
J5	1		Receptacle 100mil 3x1, Gold, TH	Receptacle, 100mil, 3x1	SSW-103-01-G-S	Samtec, Inc.	61300311821	Würth Elektronik
J6	1		Receptacle, 2.54mm, 12x1, Gold, TH	Receptacle, 2.54mm, 12x1, TH	PPPC121LFBN-RC	Sullins Connector Solutions		
J7, J8, J19, J20	4		RJ-45 with integrated magnetics	RJ-45 Jack	JK0-0177NL	Pulse Engineering	7499511611 or 7499511611A	Würth Elektronik
J9, J21	2		Connector, RJ45 with integrated magnetics, R/A, TH	RJ-45 Jack	JK0-0229NL	Pulse Engineering		
J10, J11, J12, J22, J23, J24	6		RJ-45, Vertical, TH	RJ-45 Jack, 8Pos Right Angle	SS-7188V-A-NF	Stewart Connector	615008138021	Würth Elektronik
J13, J14, J15, J16, J25, J26, J27, J28	8		Header, TH, 100mil, 2x1, Gold plated, 230 mil above insulator	TSW-102-07-G-S	TSW-102-07-G-S	Samtec, Inc.	61300211121	Würth Elektronik

⁽¹⁾ Unless otherwise noted in the *Alternate Part Number* or *Alternate Manufacturer* columns, all parts may be substituted with equivalents.

Table 10. BOOST-PSEMTHR-007 Bill of Materials⁽¹⁾ (continued)

Designator	QTY	Value	Description	Package Reference	Part Number	Manufacturer	Alternate Part Number	Alternate Manufacturer
J29	1	15A	Terminal screw, vertical, snap-in	7693	7693	Keystone		
L1	1	820uH	Inductor, Drum Core, Ferrite, 820 µH, 0.23 A, 4 ohm, SMD	SDR0805	SDR0805-821KL	Bourns		
R1	1	82.5k	RES, 82.5 k, 1%, 0.1 W, 0603	0603	CRCW060382K5FKEA	Vishay-Dale		
R2	1	10.0	RES, 10.0, 1%, 0.1 W, 0603	0603	CRCW060310R0FKEA	Vishay-Dale		
R3, R7, R8, R9, R12	5	10.0k	RES, 10.0k ohm, 1%, 0.1W, 0603	0603	CRCW060310K0FKEA	Vishay-Dale		
R4	1	13.3k	RES, 13.3k ohm, 1%, 0.1W, 0603	0603	CRCW060313K3FKEA	Vishay-Dale		
R5	1	47k	RES, 47k ohm, 5%, 0.1W, 0603	0603	CRCW060347K0JNEA	Vishay-Dale		
R6	1	6.04k	RES, 6.04k ohm, 1%, 0.1W, 0603	0603	CRCW06036K04FKEA	Vishay-Dale		
R10, R13	2	4.7k	RES, 4.7k ohm, 5%, 0.1W, 0603	0603	CRCW06034K70JNEA	Vishay-Dale		
R11	1	340	RES, 340, 1%, 0.1 W, 0603	0603	CRCW0603340RFKEA	Vishay-Dale		
R14, R15, R16, R17, R19, R20, R21, R22	8	35.7k	RES, 35.7 k, 1%, 0.25 W, 1206	1206	CRCW120635K7FKEA	Vishay-Dale		
R18	1	200k	RES, 200k ohm, 1%, 0.1W, 0603	0603	CRCW0603200KFKEA	Vishay-Dale		
SH-J1, SH-J2, SH-J3, SH-J4, SH-J5, SH-J6, SH-J7, SH-J8	8	1x2	Shunt, 100mil, Flash Gold, Black	Closed Top 100mil Shunt	SPC02SYAN	Sullins Connector Solutions		
TP1, TP2	2	Red	Test Point, Multipurpose, Red, TH	Keystone5010	5010	Keystone		
TP3, TP10, TP11, TP12, TP13	5	SMT	Test Point, Compact, SMT	Testpoint_Keystone_Compact	5016	Keystone		
TP4, TP5, TP6, TP7, TP8	5	White	Test Point, Multipurpose, White, TH	Keystone5012	5012	Keystone		
TP9	1	Black	Test Point, Multipurpose, Black, TH	Keystone5011	5011	Keystone		
U1	1		100V, 100mA Constant On-Time Synchronous Buck Regulator, DDA0008B	DDA0008B	LM5019MRX/NOPB	Texas Instruments	LM5019MR/NOPB	Texas Instruments
U2, U4	2		25 Mbps Quad Channels, 3 / 1, Digital Isolator, 3.3 V / 5 V, -40 to +125 degC, 16-pin SOIC (DW), Green (RoHS & no Sb/Br)	DW0016A	ISO7241CDW	Texas Instruments	Equivalent	None
U3	1		SINGLE BUFFER/DRIVER WITH OPEN-DRAIN OUTPUT, DCK0005A	DCK0005A	SN74LVC1G07DCK	Texas Instruments		None
C2, C5, C20	0	1uF	CAP, CERM, 1uF, 10V, ±10%, X7R, 0805	0805	0805ZC105KAT2A	AVX		
C19	0	0.1uF	CAP, CERM, 0.1uF, 50V, ±10%, X7R, 0603	0603	06035C104KAT2A	AVX		

Table 11. TPS23880EVM-008 Bill of Materials⁽¹⁾

Designator	QTY	Value	Description	Package Reference	Part Number	Manufacturer	Alternate Part Number	Alternate Manufacturer
!PCB	1		Printed Circuit Board		PSIL008	Any	-	-
C1	1	0.1uF	CAP, CERM, 0.1uF, 50V, ±10%, X7R, 0603	0603	06035C104KAT2A	AVX		
C2, C3, C4, C5, C6, C7, C8, C9, C10	9	0.1uF	CAP, CERM, 0.1uF, 100V, ±10%, X7R, 0805	0805	C2012X7R2A104K	TDK		
C11	1	1uF	CAP, CERM, 1uF, 100V, ±10%, X7R, 1206	1206	GRM31CR72A105KA01L	Murata		
D1, D2, D3, D4, D5, D6, D7, D8	8	58V	Diode, TVS, Uni, 58V, 600W, SMB	SMB	SMBJ58A-13-F	Diodes Inc.		
F1, F2, F3, F4, F5, F6, F7, F8	8		Fuse, 1.5A, 63V, SMD	1206	C1S 1.5	Bel Fuse		
J1, J2	2		Header, TH, 100mil, 10x1, Gold plated, 230 mil above insulator	TSW-110-07-G-S	TSW-110-07-G-S	Samtec, Inc.		
J3	1		Header, 100mil, 12x1, Gold, TH	12x1 Header	TSW-112-07-G-S	Samtec		
J4	1		Header, 100mil, 4x2, Gold, TH	4x2 Header	TSW-104-07-G-D	Samtec		
J5	1		Header, 100mil, 7x2, Gold, TH	7x2 Header	TSW-107-07-G-D	Samtec		
Q1, Q2, Q3, Q4, Q5, Q6, Q7, Q8	8	100V	MOSFET, N-CH, 100 V, 5 A, DNH0008A (VSONP-8)	DNH0008A	CSD19538Q3A	Texas Instruments	FDMC3612	Fairchild
R1, R2, R3, R4, R5, R6, R7, R8, R9, R10, R11, R12, R13, R14, R15, R16	16	0.51	RES, 0.51 ohm, 1%, 0.25W, 0805	0805	CRM0805-FX-R510ELF	Bourns		
SH-J1, SH-J2, SH-J3, SH-J4	4	1x2	Shunt, 100mil, Flash Gold, Black	Closed Top 100mil Shunt	SPC02SYAN	Sullins Connector Solutions		
TP1	1	Black	Test Point, Multipurpose, Black, TH	Keystone5011	5011	Keystone		
TP2, TP5, TP6	3	Red	Test Point, Miniature, Red, TH	Keystone5000	5000	Keystone		
TP3, TP4, TP7	3	White	Test Point, Miniature, White, TH	Keystone5002	5002	Keystone		
TP8	1	SMT	Test Point, Compact, SMT	Testpoint_Keystone_Compact	5016	Keystone		
U1	1		IEEE 802.3bt POWER-OVER-ETHERNET PSE CONTROLLER with SRAM, RTQ0056E (VQFN-56)	RTQ0056E	TPS23880RTQ	Texas Instruments		Texas Instruments
FID1, FID2, FID3	0		Fiducial mark. There is nothing to buy or mount.	Fiducial	N/A	N/A		
FID4, FID5, FID6	0		Fiducial mark. There is nothing to buy or mount.	N/A	N/A	N/A		
R17	0	147k	RES, 147 k, 1%, 0.125 W, 0805	0805	ERJ-6ENF1473V	Panasonic		
R18	0	64.9k	RES, 64.9 k, 1%, 0.125 W, 0805	0805	ERJ-6ENF6492V	Panasonic		
R19	0	39.2k	RES, 39.2 k, 1%, 0.125 W, 0805	0805	ERJ-6ENF3922V	Panasonic		
R20	0	23.2k	RES, 23.2 k, 1%, 0.125 W, 0805	0805	ERJ-6ENF2322V	Panasonic		
R21	0	16.2k	RES, 16.2 k, 1%, 0.125 W, 0805	0805	ERJ-6ENF1622V	Panasonic		
R22	0	11.0k	RES, 11.0 k, 1%, 0.125 W, 0805	0805	ERJ-6ENF1102V	Panasonic		
R23	0	7.68k	RES, 7.68 k, 1%, 0.125 W, 0805	0805	ERJ-6ENF7681V	Panasonic		

⁽¹⁾ Unless otherwise noted in the *Alternate Part Number* or *Alternate Manufacturer* columns, all parts may be substituted with equivalents.

Revision History

NOTE: Page numbers for previous revisions may differ from page numbers in the current version.

Changes from A Revision (June 2018) to B Revision	Page
• Changed the document status From: <i>Advanced Information</i> To <i>Production</i> data	2

STANDARD TERMS FOR EVALUATION MODULES

1. *Delivery:* TI delivers TI evaluation boards, kits, or modules, including any accompanying demonstration software, components, and/or documentation which may be provided together or separately (collectively, an "EVM" or "EVMs") to the User ("User") in accordance with the terms set forth herein. User's acceptance of the EVM is expressly subject to the following terms.
 - 1.1 EVMs are intended solely for product or software developers for use in a research and development setting to facilitate feasibility evaluation, experimentation, or scientific analysis of TI semiconductor products. EVMs have no direct function and are not finished products. EVMs shall not be directly or indirectly assembled as a part or subassembly in any finished product. For clarification, any software or software tools provided with the EVM ("Software") shall not be subject to the terms and conditions set forth herein but rather shall be subject to the applicable terms that accompany such Software
 - 1.2 EVMs are not intended for consumer or household use. EVMs may not be sold, sublicensed, leased, rented, loaned, assigned, or otherwise distributed for commercial purposes by Users, in whole or in part, or used in any finished product or production system.
2. *Limited Warranty and Related Remedies/Disclaimers:*
 - 2.1 These terms do not apply to Software. The warranty, if any, for Software is covered in the applicable Software License Agreement.
 - 2.2 TI warrants that the TI EVM will conform to TI's published specifications for ninety (90) days after the date TI delivers such EVM to User. Notwithstanding the foregoing, TI shall not be liable for a nonconforming EVM if (a) the nonconformity was caused by neglect, misuse or mistreatment by an entity other than TI, including improper installation or testing, or for any EVMs that have been altered or modified in any way by an entity other than TI, (b) the nonconformity resulted from User's design, specifications or instructions for such EVMs or improper system design, or (c) User has not paid on time. Testing and other quality control techniques are used to the extent TI deems necessary. TI does not test all parameters of each EVM. User's claims against TI under this Section 2 are void if User fails to notify TI of any apparent defects in the EVMs within ten (10) business days after delivery, or of any hidden defects with ten (10) business days after the defect has been detected.
 - 2.3 TI's sole liability shall be at its option to repair or replace EVMs that fail to conform to the warranty set forth above, or credit User's account for such EVM. TI's liability under this warranty shall be limited to EVMs that are returned during the warranty period to the address designated by TI and that are determined by TI not to conform to such warranty. If TI elects to repair or replace such EVM, TI shall have a reasonable time to repair such EVM or provide replacements. Repaired EVMs shall be warranted for the remainder of the original warranty period. Replaced EVMs shall be warranted for a new full ninety (90) day warranty period.
3. *Regulatory Notices:*
 - 3.1 *United States*
 - 3.1.1 *Notice applicable to EVMs not FCC-Approved:*

FCC NOTICE: This kit is designed to allow product developers to evaluate electronic components, circuitry, or software associated with the kit to determine whether to incorporate such items in a finished product and software developers to write software applications for use with the end product. This kit is not a finished product and when assembled may not be resold or otherwise marketed unless all required FCC equipment authorizations are first obtained. Operation is subject to the condition that this product not cause harmful interference to licensed radio stations and that this product accept harmful interference. Unless the assembled kit is designed to operate under part 15, part 18 or part 95 of this chapter, the operator of the kit must operate under the authority of an FCC license holder or must secure an experimental authorization under part 5 of this chapter.
 - 3.1.2 *For EVMs annotated as FCC – FEDERAL COMMUNICATIONS COMMISSION Part 15 Compliant:*

CAUTION

This device complies with part 15 of the FCC Rules. Operation is subject to the following two conditions: (1) This device may not cause harmful interference, and (2) this device must accept any interference received, including interference that may cause undesired operation.

Changes or modifications not expressly approved by the party responsible for compliance could void the user's authority to operate the equipment.

FCC Interference Statement for Class A EVM devices

NOTE: This equipment has been tested and found to comply with the limits for a Class A digital device, pursuant to part 15 of the FCC Rules. These limits are designed to provide reasonable protection against harmful interference when the equipment is operated in a commercial environment. This equipment generates, uses, and can radiate radio frequency energy and, if not installed and used in accordance with the instruction manual, may cause harmful interference to radio communications. Operation of this equipment in a residential area is likely to cause harmful interference in which case the user will be required to correct the interference at his own expense.

FCC Interference Statement for Class B EVM devices

NOTE: This equipment has been tested and found to comply with the limits for a Class B digital device, pursuant to part 15 of the FCC Rules. These limits are designed to provide reasonable protection against harmful interference in a residential installation. This equipment generates, uses and can radiate radio frequency energy and, if not installed and used in accordance with the instructions, may cause harmful interference to radio communications. However, there is no guarantee that interference will not occur in a particular installation. If this equipment does cause harmful interference to radio or television reception, which can be determined by turning the equipment off and on, the user is encouraged to try to correct the interference by one or more of the following measures:

- Reorient or relocate the receiving antenna.
- Increase the separation between the equipment and receiver.
- Connect the equipment into an outlet on a circuit different from that to which the receiver is connected.
- Consult the dealer or an experienced radio/TV technician for help.

3.2 Canada

3.2.1 For EVMs issued with an Industry Canada Certificate of Conformance to RSS-210 or RSS-247

Concerning EVMs Including Radio Transmitters:

This device complies with Industry Canada license-exempt RSSs. Operation is subject to the following two conditions:

(1) this device may not cause interference, and (2) this device must accept any interference, including interference that may cause undesired operation of the device.

Concernant les EVMs avec appareils radio:

Le présent appareil est conforme aux CNR d'Industrie Canada applicables aux appareils radio exempts de licence. L'exploitation est autorisée aux deux conditions suivantes: (1) l'appareil ne doit pas produire de brouillage, et (2) l'utilisateur de l'appareil doit accepter tout brouillage radioélectrique subi, même si le brouillage est susceptible d'en compromettre le fonctionnement.

Concerning EVMs Including Detachable Antennas:

Under Industry Canada regulations, this radio transmitter may only operate using an antenna of a type and maximum (or lesser) gain approved for the transmitter by Industry Canada. To reduce potential radio interference to other users, the antenna type and its gain should be so chosen that the equivalent isotropically radiated power (e.i.r.p.) is not more than that necessary for successful communication. This radio transmitter has been approved by Industry Canada to operate with the antenna types listed in the user guide with the maximum permissible gain and required antenna impedance for each antenna type indicated. Antenna types not included in this list, having a gain greater than the maximum gain indicated for that type, are strictly prohibited for use with this device.

Concernant les EVMs avec antennes détachables

Conformément à la réglementation d'Industrie Canada, le présent émetteur radio peut fonctionner avec une antenne d'un type et d'un gain maximal (ou inférieur) approuvé pour l'émetteur par Industrie Canada. Dans le but de réduire les risques de brouillage radioélectrique à l'intention des autres utilisateurs, il faut choisir le type d'antenne et son gain de sorte que la puissance isotrope rayonnée équivalente (p.i.r.e.) ne dépasse pas l'intensité nécessaire à l'établissement d'une communication satisfaisante. Le présent émetteur radio a été approuvé par Industrie Canada pour fonctionner avec les types d'antenne énumérés dans le manuel d'usage et ayant un gain admissible maximal et l'impédance requise pour chaque type d'antenne. Les types d'antenne non inclus dans cette liste, ou dont le gain est supérieur au gain maximal indiqué, sont strictement interdits pour l'exploitation de l'émetteur.

3.3 Japan

3.3.1 *Notice for EVMs delivered in Japan:* Please see http://www.tij.co.jp/lstds/ti_ja/general/eStore/notice_01.page 日本国内に輸入される評価用キット、ボードについては、次のところをご覧ください。
http://www.tij.co.jp/lstds/ti_ja/general/eStore/notice_01.page

3.3.2 *Notice for Users of EVMs Considered "Radio Frequency Products" in Japan:* EVMs entering Japan may not be certified by TI as conforming to Technical Regulations of Radio Law of Japan.

If User uses EVMs in Japan, not certified to Technical Regulations of Radio Law of Japan, User is required to follow the instructions set forth by Radio Law of Japan, which includes, but is not limited to, the instructions below with respect to EVMs (which for the avoidance of doubt are stated strictly for convenience and should be verified by User):

1. Use EVMs in a shielded room or any other test facility as defined in the notification #173 issued by Ministry of Internal Affairs and Communications on March 28, 2006, based on Sub-section 1.1 of Article 6 of the Ministry's Rule for Enforcement of Radio Law of Japan,
2. Use EVMs only after User obtains the license of Test Radio Station as provided in Radio Law of Japan with respect to EVMs, or
3. Use of EVMs only after User obtains the Technical Regulations Conformity Certification as provided in Radio Law of Japan with respect to EVMs. Also, do not transfer EVMs, unless User gives the same notice above to the transferee. Please note that if User does not follow the instructions above, User will be subject to penalties of Radio Law of Japan.

【無線電波を送信する製品の開発キットをお使いになる際の注意事項】 開発キットの中には技術基準適合証明を受けていないものがあります。技術適合証明を受けていないものご使用に際しては、電波法遵守のため、以下のいずれかの措置を取っていただく必要がありますのでご注意ください。

1. 電波法施行規則第6条第1項第1号に基づく平成18年3月28日総務省告示第173号で定められた電波暗室等の試験設備でご使用いただく。
2. 実験局の免許を取得後ご使用いただく。
3. 技術基準適合証明を取得後ご使用いただく。

なお、本製品は、上記の「ご使用にあたっての注意」を譲渡先、移転先に通知しない限り、譲渡、移転できないものとします。

上記を遵守頂けない場合は、電波法の罰則が適用される可能性があることをご留意ください。日本テキサス・インスツルメンツ株式会社

東京都新宿区西新宿 6 丁目 2 4 番 1 号
西新宿三井ビル

3.3.3 *Notice for EVMs for Power Line Communication:* Please see http://www.tij.co.jp/llds/ti_ja/general/eStore/notice_02.page
電力線搬送波通信についての開発キットをお使いになる際の注意事項については、次のところをご覧ください。 http://www.tij.co.jp/llds/ti_ja/general/eStore/notice_02.page

3.4 *European Union*

3.4.1 *For EVMs subject to EU Directive 2014/30/EU (Electromagnetic Compatibility Directive):*

This is a class A product intended for use in environments other than domestic environments that are connected to a low-voltage power-supply network that supplies buildings used for domestic purposes. In a domestic environment this product may cause radio interference in which case the user may be required to take adequate measures.

4 *EVM Use Restrictions and Warnings:*

4.1 EVMS ARE NOT FOR USE IN FUNCTIONAL SAFETY AND/OR SAFETY CRITICAL EVALUATIONS, INCLUDING BUT NOT LIMITED TO EVALUATIONS OF LIFE SUPPORT APPLICATIONS.

4.2 User must read and apply the user guide and other available documentation provided by TI regarding the EVM prior to handling or using the EVM, including without limitation any warning or restriction notices. The notices contain important safety information related to, for example, temperatures and voltages.

4.3 *Safety-Related Warnings and Restrictions:*

4.3.1 User shall operate the EVM within TI's recommended specifications and environmental considerations stated in the user guide, other available documentation provided by TI, and any other applicable requirements and employ reasonable and customary safeguards. Exceeding the specified performance ratings and specifications (including but not limited to input and output voltage, current, power, and environmental ranges) for the EVM may cause personal injury or death, or property damage. If there are questions concerning performance ratings and specifications, User should contact a TI field representative prior to connecting interface electronics including input power and intended loads. Any loads applied outside of the specified output range may also result in unintended and/or inaccurate operation and/or possible permanent damage to the EVM and/or interface electronics. Please consult the EVM user guide prior to connecting any load to the EVM output. If there is uncertainty as to the load specification, please contact a TI field representative. During normal operation, even with the inputs and outputs kept within the specified allowable ranges, some circuit components may have elevated case temperatures. These components include but are not limited to linear regulators, switching transistors, pass transistors, current sense resistors, and heat sinks, which can be identified using the information in the associated documentation. When working with the EVM, please be aware that the EVM may become very warm.

4.3.2 EVMs are intended solely for use by technically qualified, professional electronics experts who are familiar with the dangers and application risks associated with handling electrical mechanical components, systems, and subsystems. User assumes all responsibility and liability for proper and safe handling and use of the EVM by User or its employees, affiliates, contractors or designees. User assumes all responsibility and liability to ensure that any interfaces (electronic and/or mechanical) between the EVM and any human body are designed with suitable isolation and means to safely limit accessible leakage currents to minimize the risk of electrical shock hazard. User assumes all responsibility and liability for any improper or unsafe handling or use of the EVM by User or its employees, affiliates, contractors or designees.

4.4 User assumes all responsibility and liability to determine whether the EVM is subject to any applicable international, federal, state, or local laws and regulations related to User's handling and use of the EVM and, if applicable, User assumes all responsibility and liability for compliance in all respects with such laws and regulations. User assumes all responsibility and liability for proper disposal and recycling of the EVM consistent with all applicable international, federal, state, and local requirements.

5. *Accuracy of Information:* To the extent TI provides information on the availability and function of EVMs, TI attempts to be as accurate as possible. However, TI does not warrant the accuracy of EVM descriptions, EVM availability or other information on its websites as accurate, complete, reliable, current, or error-free.

6. *Disclaimers:*
- 6.1 EXCEPT AS SET FORTH ABOVE, EVMS AND ANY MATERIALS PROVIDED WITH THE EVM (INCLUDING, BUT NOT LIMITED TO, REFERENCE DESIGNS AND THE DESIGN OF THE EVM ITSELF) ARE PROVIDED "AS IS" AND "WITH ALL FAULTS." TI DISCLAIMS ALL OTHER WARRANTIES, EXPRESS OR IMPLIED, REGARDING SUCH ITEMS, INCLUDING BUT NOT LIMITED TO ANY EPIDEMIC FAILURE WARRANTY OR IMPLIED WARRANTIES OF MERCHANTABILITY OR FITNESS FOR A PARTICULAR PURPOSE OR NON-INFRINGEMENT OF ANY THIRD PARTY PATENTS, COPYRIGHTS, TRADE SECRETS OR OTHER INTELLECTUAL PROPERTY RIGHTS.
- 6.2 EXCEPT FOR THE LIMITED RIGHT TO USE THE EVM SET FORTH HEREIN, NOTHING IN THESE TERMS SHALL BE CONSTRUED AS GRANTING OR CONFERRING ANY RIGHTS BY LICENSE, PATENT, OR ANY OTHER INDUSTRIAL OR INTELLECTUAL PROPERTY RIGHT OF TI, ITS SUPPLIERS/LICENSORS OR ANY OTHER THIRD PARTY, TO USE THE EVM IN ANY FINISHED END-USER OR READY-TO-USE FINAL PRODUCT, OR FOR ANY INVENTION, DISCOVERY OR IMPROVEMENT, REGARDLESS OF WHEN MADE, CONCEIVED OR ACQUIRED.
7. *USER'S INDEMNITY OBLIGATIONS AND REPRESENTATIONS.* USER WILL DEFEND, INDEMNIFY AND HOLD TI, ITS LICENSORS AND THEIR REPRESENTATIVES HARMLESS FROM AND AGAINST ANY AND ALL CLAIMS, DAMAGES, LOSSES, EXPENSES, COSTS AND LIABILITIES (COLLECTIVELY, "CLAIMS") ARISING OUT OF OR IN CONNECTION WITH ANY HANDLING OR USE OF THE EVM THAT IS NOT IN ACCORDANCE WITH THESE TERMS. THIS OBLIGATION SHALL APPLY WHETHER CLAIMS ARISE UNDER STATUTE, REGULATION, OR THE LAW OF TORT, CONTRACT OR ANY OTHER LEGAL THEORY, AND EVEN IF THE EVM FAILS TO PERFORM AS DESCRIBED OR EXPECTED.
8. *Limitations on Damages and Liability:*
- 8.1 *General Limitations.* IN NO EVENT SHALL TI BE LIABLE FOR ANY SPECIAL, COLLATERAL, INDIRECT, PUNITIVE, INCIDENTAL, CONSEQUENTIAL, OR EXEMPLARY DAMAGES IN CONNECTION WITH OR ARISING OUT OF THESE TERMS OR THE USE OF THE EVMS , REGARDLESS OF WHETHER TI HAS BEEN ADVISED OF THE POSSIBILITY OF SUCH DAMAGES. EXCLUDED DAMAGES INCLUDE, BUT ARE NOT LIMITED TO, COST OF REMOVAL OR REINSTALLATION, ANCILLARY COSTS TO THE PROCUREMENT OF SUBSTITUTE GOODS OR SERVICES, RETESTING, OUTSIDE COMPUTER TIME, LABOR COSTS, LOSS OF GOODWILL, LOSS OF PROFITS, LOSS OF SAVINGS, LOSS OF USE, LOSS OF DATA, OR BUSINESS INTERRUPTION. NO CLAIM, SUIT OR ACTION SHALL BE BROUGHT AGAINST TI MORE THAN TWELVE (12) MONTHS AFTER THE EVENT THAT GAVE RISE TO THE CAUSE OF ACTION HAS OCCURRED.
- 8.2 *Specific Limitations.* IN NO EVENT SHALL TI'S AGGREGATE LIABILITY FROM ANY USE OF AN EVM PROVIDED HEREUNDER, INCLUDING FROM ANY WARRANTY, INDEMNITY OR OTHER OBLIGATION ARISING OUT OF OR IN CONNECTION WITH THESE TERMS, , EXCEED THE TOTAL AMOUNT PAID TO TI BY USER FOR THE PARTICULAR EVM(S) AT ISSUE DURING THE PRIOR TWELVE (12) MONTHS WITH RESPECT TO WHICH LOSSES OR DAMAGES ARE CLAIMED. THE EXISTENCE OF MORE THAN ONE CLAIM SHALL NOT ENLARGE OR EXTEND THIS LIMIT.
9. *Return Policy.* Except as otherwise provided, TI does not offer any refunds, returns, or exchanges. Furthermore, no return of EVM(s) will be accepted if the package has been opened and no return of the EVM(s) will be accepted if they are damaged or otherwise not in a resalable condition. If User feels it has been incorrectly charged for the EVM(s) it ordered or that delivery violates the applicable order, User should contact TI. All refunds will be made in full within thirty (30) working days from the return of the components(s), excluding any postage or packaging costs.
10. *Governing Law:* These terms and conditions shall be governed by and interpreted in accordance with the laws of the State of Texas, without reference to conflict-of-laws principles. User agrees that non-exclusive jurisdiction for any dispute arising out of or relating to these terms and conditions lies within courts located in the State of Texas and consents to venue in Dallas County, Texas. Notwithstanding the foregoing, any judgment may be enforced in any United States or foreign court, and TI may seek injunctive relief in any United States or foreign court.

IMPORTANT NOTICE AND DISCLAIMER

TI PROVIDES TECHNICAL AND RELIABILITY DATA (INCLUDING DATASHEETS), DESIGN RESOURCES (INCLUDING REFERENCE DESIGNS), APPLICATION OR OTHER DESIGN ADVICE, WEB TOOLS, SAFETY INFORMATION, AND OTHER RESOURCES "AS IS" AND WITH ALL FAULTS, AND DISCLAIMS ALL WARRANTIES, EXPRESS AND IMPLIED, INCLUDING WITHOUT LIMITATION ANY IMPLIED WARRANTIES OF MERCHANTABILITY, FITNESS FOR A PARTICULAR PURPOSE OR NON-INFRINGEMENT OF THIRD PARTY INTELLECTUAL PROPERTY RIGHTS.

These resources are intended for skilled developers designing with TI products. You are solely responsible for (1) selecting the appropriate TI products for your application, (2) designing, validating and testing your application, and (3) ensuring your application meets applicable standards, and any other safety, security, or other requirements. These resources are subject to change without notice. TI grants you permission to use these resources only for development of an application that uses the TI products described in the resource. Other reproduction and display of these resources is prohibited. No license is granted to any other TI intellectual property right or to any third party intellectual property right. TI disclaims responsibility for, and you will fully indemnify TI and its representatives against, any claims, damages, costs, losses, and liabilities arising out of your use of these resources.

TI's products are provided subject to TI's Terms of Sale (www.ti.com/legal/termsofsale.html) or other applicable terms available either on ti.com or provided in conjunction with such TI products. TI's provision of these resources does not expand or otherwise alter TI's applicable warranties or warranty disclaimers for TI products.

Mailing Address: Texas Instruments, Post Office Box 655303, Dallas, Texas 75265
Copyright © 2018, Texas Instruments Incorporated