

# > em4

## Accessories

### RS485 Modbus slave interfaces

- > Modbus RTU or ASCII RS485 slave standard widely used in industry
- > Useful to connect one or several em4 to a programmable touch panel or a SCADA
- > The removable connector allows to unplug em4 without cutting the network
- > Includes End Of Line resistors
- > Direct connection with screw terminals without the need external accessories
- > Black or white color to match with the corresponding design of your em4



RS485 interface - Black



RS485 interface - White

#### Specific characteristics

Part number	88 980 120	88 980 121
Finish	Glossy black	Glossy white
Color	Black RAL 9011	White RAL 9003

#### General characteristics

Protocol	Slave Modbus
Compatible	Base 24 VDC power supply version
Protection rating (in accordance with IEC/EN 60529)	IP 20
Type	2 wires
transmission mode	RTU 8 bits ASCII 7 bits
Parity	None, even, odd
Stop bit	1 or 2
Transmission rate	1200, 2400, 4800, 9600, 19200, 28800, 38400, 57600 bauds
Addressing	From 1 to 247
Compatible connector	Phoenix contact: 1916410 Dinkle: EC350V-04P-BK Framatome connectors: 20020004-C042B01LF (Included with the interface)
Weight	Without packing: 13 g With packing: 15 g
Dimensions	Without packing: 35 x 36 x 26 mm / 1.38 x 1.42 x 1.02 inch With packing: 93 x 103 x 30 mm / 3.66 x 4.06 x 1.18 inch

Diagrams

Dimensions

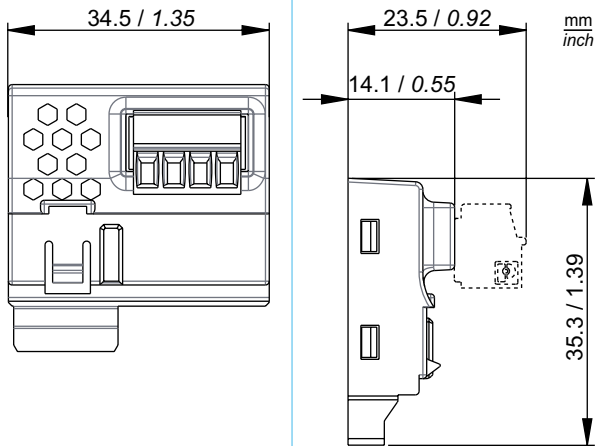

Connections

