

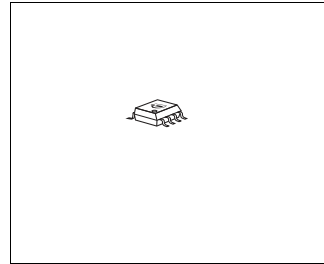

Features

- Adjustable constant output current
- Wide input voltage range
- Low drop voltage
- Open load detection
- Overtemperature protection
- Short circuit proof
- Reverse polarity proof
- Wide temperature range: $-40\text{ °C} < T_j < 150\text{ °C}$
- Very small SMD-Package
- Green Product (RoHS compliant)
- AEC Qualified



Functional Description

The **TLE4241GM** is an integrated adjustable constant current source. It provides an output current adjustable via different means (SET, PWM, reference resistor) which is kept nearly independent from load and supply voltage changes. The IC is designed to supply LEDs under the severe conditions of automotive applications resulting in constant brightness and extended LED lifetime. It is provided in the very small P-DSO-8-9 (Micro 8) package. Protection circuits prevent damage to the device in case of overload, short circuit, reverse polarity and overtemperature. The connected LEDs are protected against reverse polarity as well as excess voltages up to 45 V. A status output allows handling of open load and short circuit at the main output.

A PWM input offers the possibility to adjust the LED brightness by pulse width modulation.

With an implemented high/low current switch the output current level can be reduced e.g. for brake/tail light application.

The implemented features such as adjustable output current, the high/low current switch and the provided PWM input make the device well suited for a broad range of LED and other applications.

| Type | Package |
|-----------|-----------|
| TLE4241GM | P-DSO-8-9 |

Circuit Description

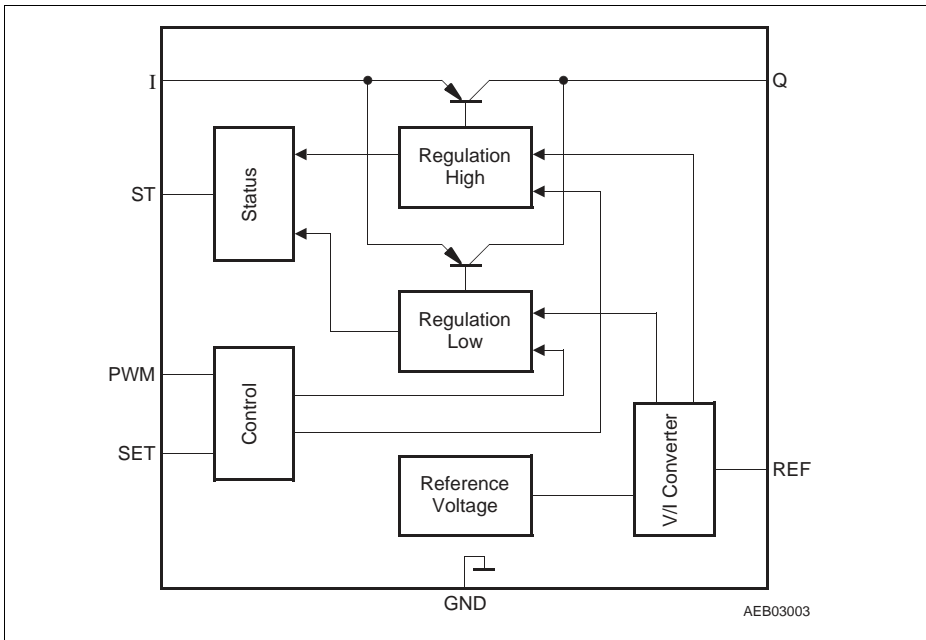

Figure 1 Block Diagram

An internal reference voltage of typ. 1.20 V supplies the REF pin which is connected to GND via an external resistor. In the SET = H mode the reference current flowing on the REF pin is mirrored with an amplification to form the desired output current. The typ. output current in the SET = H mode calculates:

$$I_{Q, \text{typ}}/\text{mA} = \frac{1.20}{R_{\text{REF}}/\text{k}\Omega} \times 487 + 0.1 \quad (1)$$

The output current is shown as a function of the reference resistance on [Page 10](#) for the high as well as for the low current mode.

With the PWM input the LED brightness can be regulated via duty cycle. Also PWM = L sets the TLE4241 in sleep mode resulting in a very low current consumption of $\ll 1 \mu\text{A}$ typ. Due to the high impedance of the PWM input (see timing diagram I_{PWM} versus V_{PWM} on [Page 12](#)) the PWM pin can thus also be used as an Enable input.

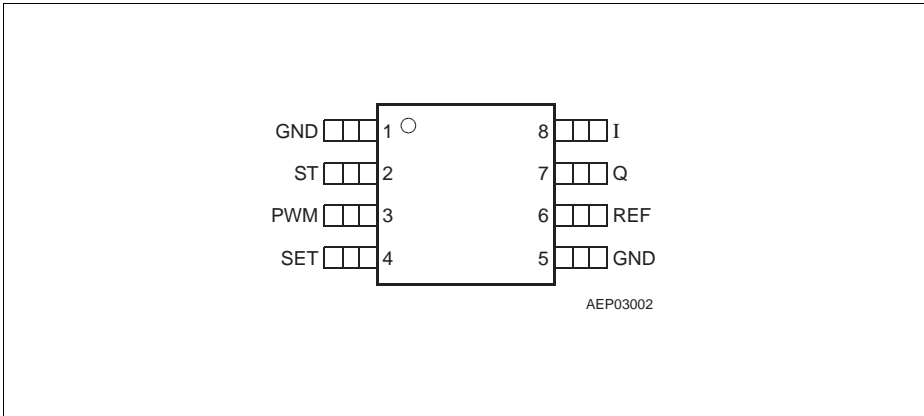

Figure 2 Pin Configuration (top view)

Table 1 Pin Definitions and Functions

| Pin No. | Symbol | Function |
|---------|--------|--|
| 1 | GND | Ground ; internally connected to pin 5 |
| 2 | ST | Status Output ; open collector output, connect to external pull-up resistor (10 kΩ or higher) |
| 3 | PWM | Pulse Width Modulation Input ; if not needed connect to V_I |
| 4 | SET | High/Low Current Input ; choice of current level |
| 5 | GND | Ground ; internally connected to pin 1 |
| 6 | REF | Reference Input ; connect to GND via an external resistor to adjust the output current |
| 7 | Q | Output |
| 8 | I | Input ; block to GND directly at the IC with a 100 nF ceramic capacitor |

Application Information

Figure 3 Application Circuit

Figure 3 shows a typical application with the TLE4241GM LITIX™ Linear. The 3 LEDs are driven with an adequate supply current adjusted by the resistor R_{REF} . Thus brightness variations due to forward voltage spread of the LEDs are prevented. The luminosity spread arising from the LED production process can be compensated via software by an appropriate duty cycle applied to the PWM pin. Hence selection of the LEDs to forward voltage as well as to luminosity classes can be spared. The slightly negative temperature coefficient of the TLE4241GM output current protects the LEDs against over-temperature stress if the IC is placed nearby the LEDs.

The voltage drop ($V_I - V_Q$) across the TLE4241GM is monitored in order to detect an open load condition indicated at the status output pin ST. In case of open load, the voltage drop will decrease below the lower status switching threshold $V_{dr,L}$. Hence, the status output ST will be driven low. In normal operation, the voltage drop is above the upper status threshold $V_{dr,H}$, thus the open collector output ST is in high-ohmic state (see also section Status Output at the Electrical Characteristics).

The function of ST, SET and PWM as well as their timings are shown in **Figure 4**.

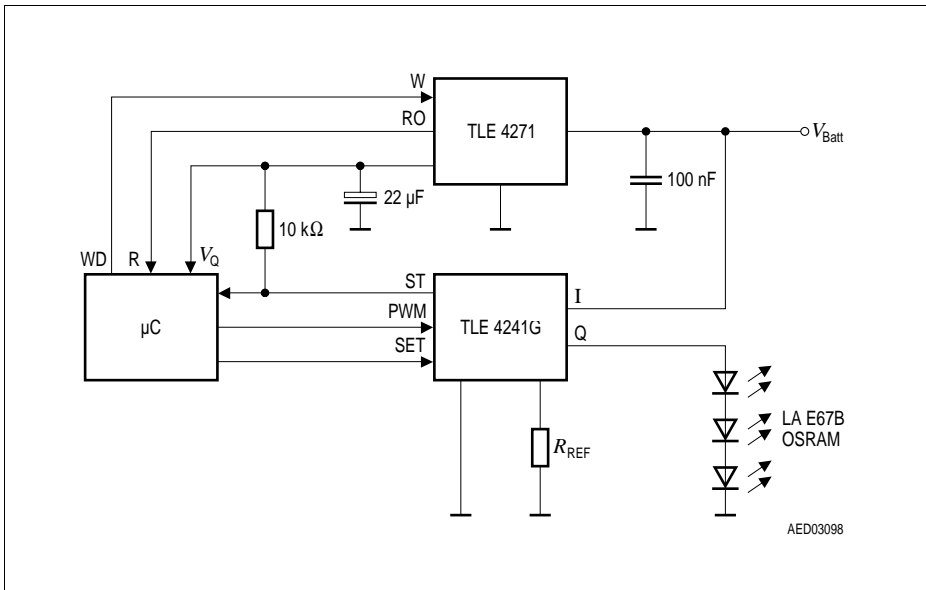
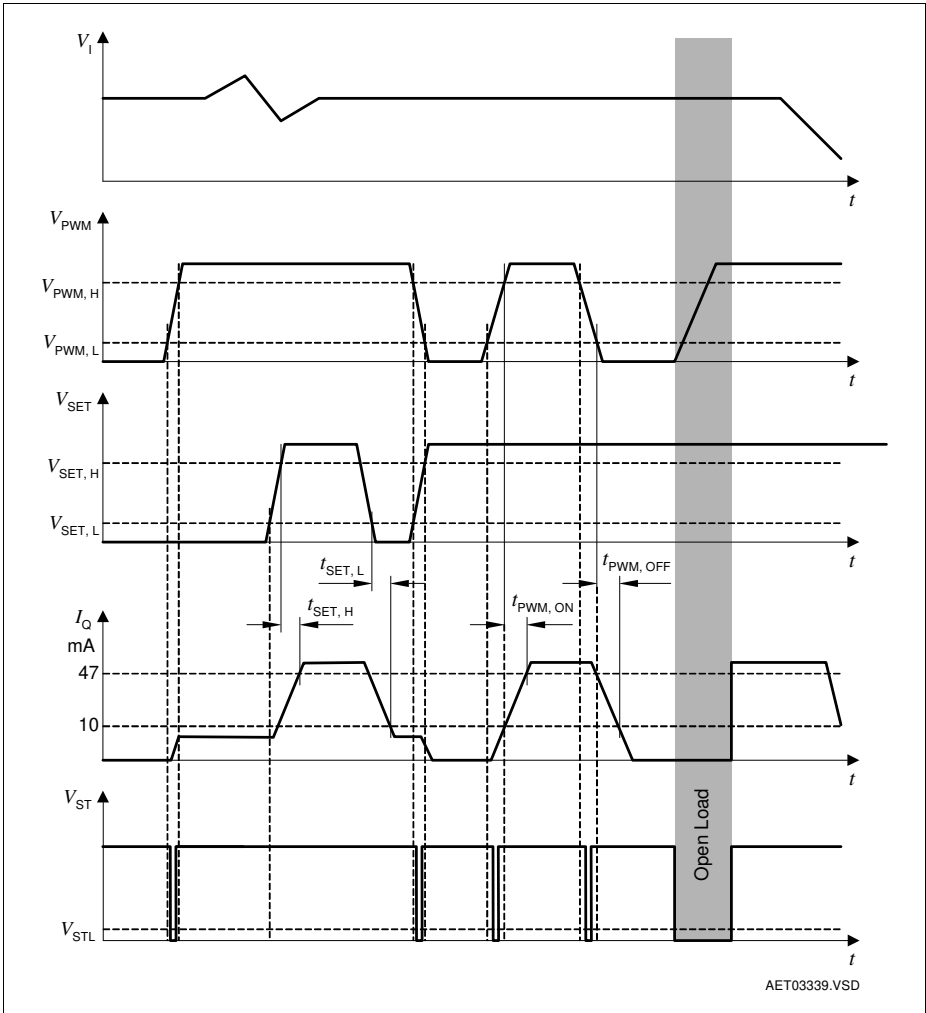

Figure 4 Function and Timing Diagram

Table 2 Absolute Maximum Ratings
 $-40\text{ °C} < T_j < 150\text{ °C}$

| Parameter | Symbol | Limit Values | | Unit | Remarks |
|-------------------------------------|------------|--------------|------|------|--------------------|
| | | Min. | Max. | | |
| Input | | | | | |
| Voltage | V_I | -42 | 45 | V | – |
| Current | I_I | – | – | mA | internally limited |
| Output | | | | | |
| Voltage | V_Q | -1 | 40 | V | – |
| Current | I_Q | – | – | mA | internally limited |
| Status Output | | | | | |
| Voltage | V_{ST} | -0.3 | 40 | V | – |
| Current | I_{ST} | – 5 | 5 | mA | internally limited |
| Reference Input | | | | | |
| Voltage | V_{REF} | -0.3 | 7 | V | – |
| Current | I_{REF} | -2 | 2 | mA | – |
| Pulse Width Modulation Input | | | | | |
| Voltage | V_{PWM} | -40 | 40 | V | – |
| Current | – | -1 | 1 | mA | – |
| High/Low Current Input | | | | | |
| Voltage | V_{SET} | -40 | 40 | V | – |
| Current | I_{SET} | -1 | 1 | mA | – |
| Temperatures | | | | | |
| Junction temperature | T_j | -40 | 150 | °C | – |
| Storage temperature | T_{stg} | -50 | 150 | °C | – |
| Thermal Resistances | | | | | |
| Junction ambient | R_{thja} | – | 105 | K/W | ¹⁾ |

1) Worst case regarding peak temperature; mounted on PCB $80 \times 80 \times 1.5\text{ mm}^3$, $35\text{ }\mu\text{m Cu}$, 300 mm^2 heat sink area.

Note: Maximum ratings are absolute ratings; exceeding any one of these values may cause irreversible damage to the integrated circuit.

Table 3 Operating Range

| Parameter | Symbol | Limit Values | | Unit | Remarks |
|-----------------------|-----------|--------------|------|------|---------|
| | | Min. | Max. | | |
| Input voltage | V_I | 4 | 45 | V | – |
| Status output voltage | V_{ST} | – | 16 | V | – |
| SET voltage | V_{SET} | 0 | 40 | V | – |
| PWM voltage | V_{PWM} | 0 | 40 | V | – |
| Junction temperature | T_j | -40 | 150 | °C | – |
| Reference Resistor | R_{REF} | 7 | 100 | kΩ | SET = H |
| | | 4.7 | 18 | kΩ | SET = L |

Table 4 Electrical Characteristics

9 V ≤ V_I ≤ 16 V; R_{REF} = 10 kΩ; V_{PWM} ≥ V_{PWM,H}; -40 °C < T_J < 150 °C; all voltages with respect to ground; positive current defined flowing into pin; unless otherwise specified

| Parameter | Symbol | Limit Values | | | Unit | Test Condition |
|-------------------------------|-------------------|--------------|------|------|------|--|
| | | Min. | Typ. | Max. | | |
| Current consumption off mode | I _{qOFF} | – | 0.1 | 4 | μA | PWM = L, T _J < 85 °C; V _I ≤ 13.5 V |
| Current consumption | I _{qL} | – | 4 | 7 | mA | SET = L; V _Q = 6 V |
| Current consumption | I _{qH} | – | 5 | 7 | mA | SET = H; V _Q = 6 V |
| Current consumption open load | I _{qL,O} | – | – | 8 | mA | SET = L; V _Q open |
| Current consumption open load | I _{qH,O} | – | – | 8 | mA | SET = H; V _Q open |

Output

| | | | | | | |
|----------------------|----------------------------------|----|------|-----|----|--|
| Output current | I _Q | 7 | 8.4 | 9.5 | mA | SET = L, V _Q = 6 V |
| | | – | 8.6 | – | mA | SET = L, V _Q = 4 V |
| Output current | I _Q | 50 | 58.5 | 65 | mA | SET = H, V _Q = 6 V |
| | | – | 60.0 | – | mA | SET = H, V _Q = 4 V |
| Current Ratio | I _{QH} /I _{QL} | 6 | 7 | 8 | – | – |
| Output current limit | I _{Qmax} | – | 83 | – | mA | SET = L; R _{REF} = 0 Ω |
| Output current limit | I _{Qmax} | – | 83 | – | mA | SET = H; R _{REF} = 0 Ω |
| Drop voltage | V _{dr} | – | 0.2 | 0.5 | V | SET = L; I _Q = 80% of I _{Q,nom,L} |
| Drop voltage | V _{dr} | – | 0.3 | 0.5 | V | SET = H; I _Q = 80% of I _{Q,nom,H} |

PWM Input

| | | | | | | |
|------------------------------|---------------------|-----|-----|-----|----|--|
| PWM high level | V _{PWM,H} | 2.0 | – | – | V | – |
| PWM low level | V _{PWM,L} | – | – | 0.5 | V | – |
| PWM input current high level | I _{PWM,H} | – | 220 | 500 | μA | V _{PWM} = 5.0 V |
| PWM input current low level | I _{PWM,L} | -10 | – | 10 | μA | V _{PWM} = 0.0 V |
| Turn on delay time | t _{PWM,ON} | 0 | 5 | 30 | μs | 20%/80% I _Q , see Figure 4 |

Table 4 Electrical Characteristics (cont'd)

$9\text{ V} \leq V_1 \leq 16\text{ V}$; $R_{REF} = 10\text{ k}\Omega$; $V_{PWM} \geq V_{PWM,H}$; $-40\text{ }^\circ\text{C} < T_j < 150\text{ }^\circ\text{C}$; all voltages with respect to ground; positive current defined flowing into pin; unless otherwise specified

| Parameter | Symbol | Limit Values | | | Unit | Test Condition |
|---------------------|---------------|--------------|------|------|---------------|--|
| | | Min. | Typ. | Max. | | |
| Turn off delay time | $t_{PWM,OFF}$ | 0 | 10 | 30 | μs | 20%/80% I_Q , see Figure 4 |

SET Input

| | | | | | | |
|------------------------------|-------------|-----|-----|-----|---------------|--|
| SET high level | $V_{SET,H}$ | 2.0 | – | – | V | – |
| SET low level | $V_{SET,L}$ | – | – | 0.5 | V | – |
| SET input current high level | $I_{SET,H}$ | – | 220 | 500 | μA | $V_{SET} = 5.0\text{ V}$ |
| SET input current low level | $I_{SET,L}$ | -10 | – | 10 | μA | $V_{SET} = 0.0\text{ V}$ |
| Delay time L -> H | $t_{SET,H}$ | – | – | 30 | μs | 20%/80% I_Q , see Figure 4 |
| Delay time H -> L | $t_{SET,L}$ | – | – | 30 | μs | 20%/80% I_Q , see Figure 4 |

Status Output

| | | | | | | |
|----------------------------------|------------|------|---|-----|---------------|--|
| Lower status switching threshold | $V_{dr,L}$ | 0.15 | – | – | V | $(V_1 - V_Q)$ decreasing SET = L |
| | | 0.15 | – | – | V | $(V_1 - V_Q)$ decreasing SET = H |
| Upper status switching threshold | $V_{dr,H}$ | – | – | 0.7 | V | $(V_1 - V_Q)$ increasing SET = L |
| | | – | – | 0.7 | V | $(V_1 - V_Q)$ increasing SET = H |
| Status low voltage | V_{STL} | – | – | 0.4 | V | $(V_1 - V_Q) < V_{dr,L}$ $I_{ST} = 1.0\text{ mA}$ |
| Leakage current | I_{STLK} | – | – | 10 | μA | $(V_1 - V_Q) > V_{dr,H}$ $V_{ST} = 5.0\text{ V}$ |

Typical Performance Characteristics

Output Current versus External Resistor, SET = H

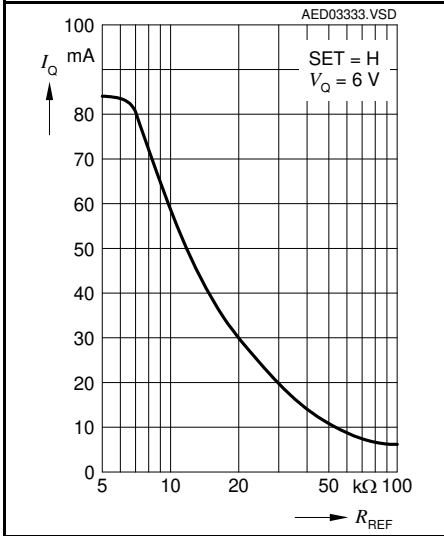

Output Current versus External Resistor, SET = L

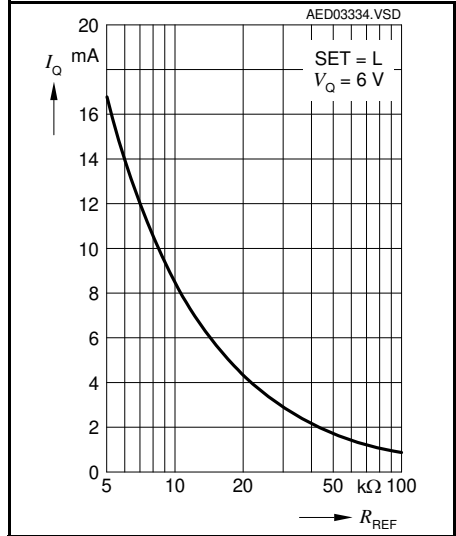

Output Current versus Supply Voltage, SET = H

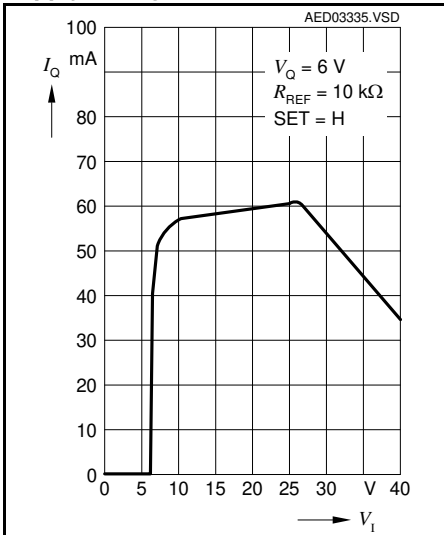

Output Current versus Supply Voltage, SET = L

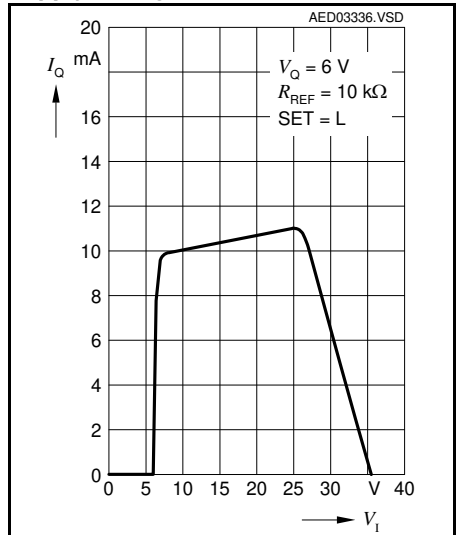

**Reference Voltage versus
Junction Temperature**

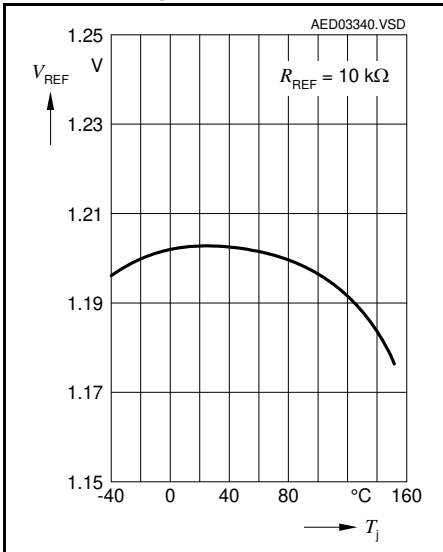

PWM Pin Input Current versus PWM Voltage

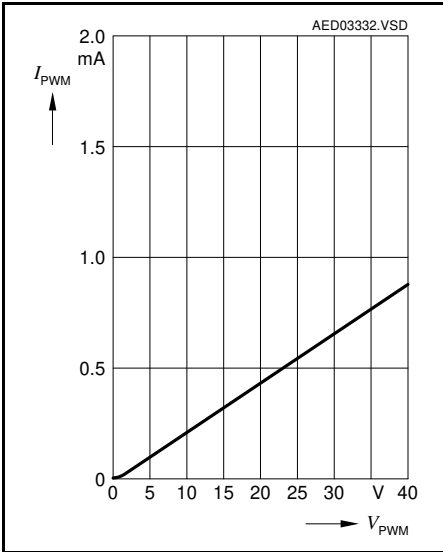

PWM Pin Input Current versus PWM Voltage

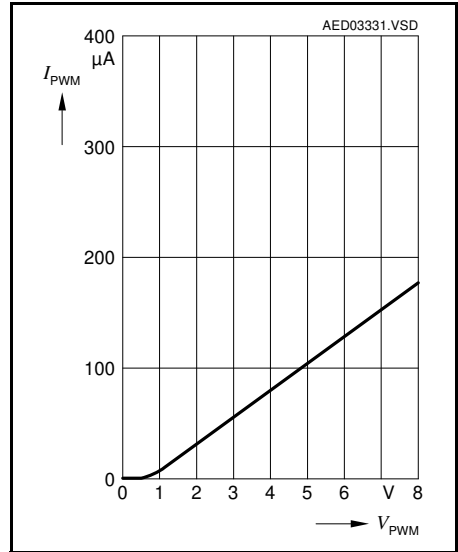

SET Pin Input Current versus SET Voltage

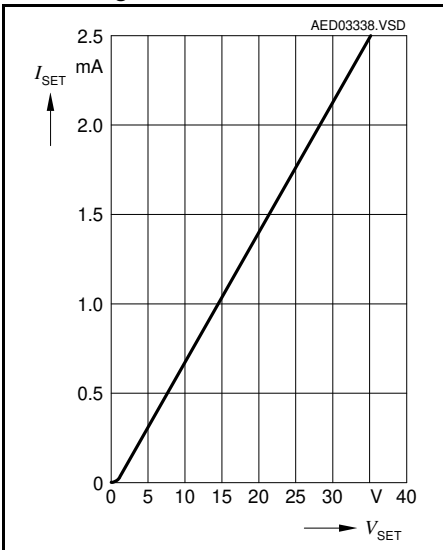

SET Pin Input Current versus SET Voltage

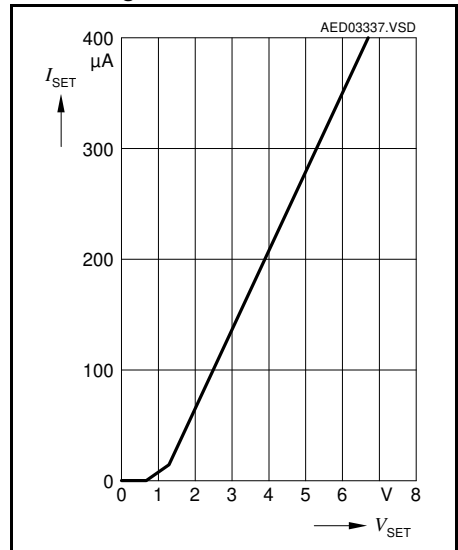

Package Outlines

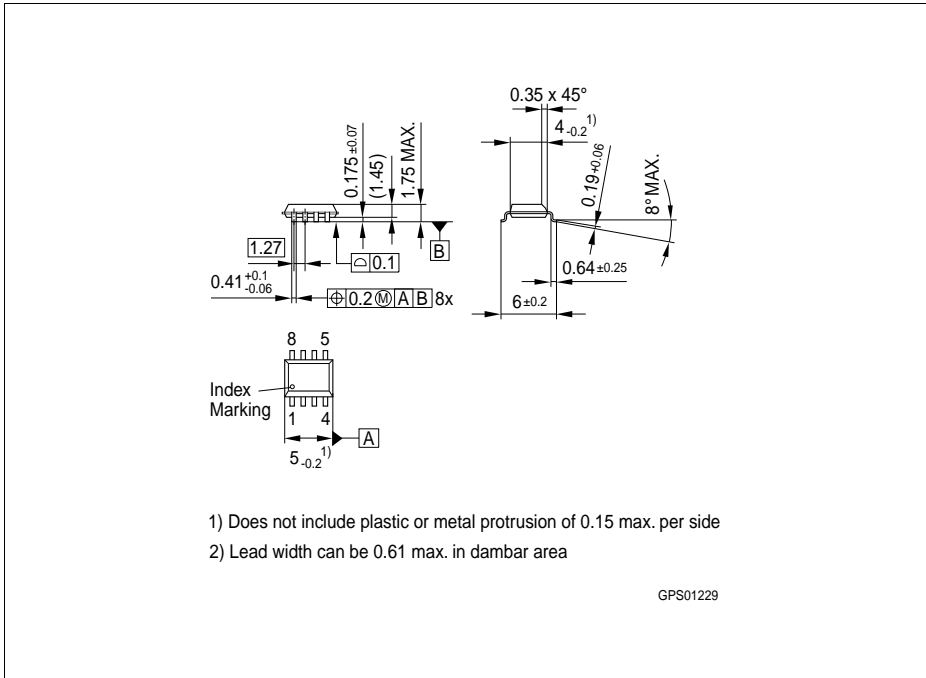

Figure 5 P-DSO-8-9 (Plastic Dual Small Outline)

Green Product (RoHS compliant)

To meet the world-wide customer requirements for environmentally friendly products and to be compliant with government regulations the device is available as a green product. Green products are RoHS-Compliant (i.e Pb-free finish on leads and suitable for Pb-free soldering according to IPC/JEDEC J-STD-020).

You can find all of our packages, sorts of packing and others in our Infineon Internet Page "Products": <http://www.infineon.com/products>.

SMD = Surface Mounted Device

Dimensions in mm

Revision History

| Version | Date | Changes |
|----------------|-------------|--|
| Rev. 1.2 | 2004-04-13 | Page 4, 9: Improved indication and explanation of the open load detection function. |
| Rev. 1.3 | 2007-03-19 | Initial version of RoHS-compliant derivate of TLE4241GM Page 1 : AEC certified statement added Page 1 and Page 13 : RoHS compliance statement and Green product feature added Page 1 and Page 13 : Package changed to RoHS compliant version Legal Disclaimer updated |
| Rev. 1.4 | 2015-07-09 | Electrical Characteristics updated Page 8 |

Edition 2015-10-05

**Published by
Infineon Technologies AG
81726 Munich, Germany**

**© 2004 Infineon Technologies AG
All Rights Reserved.**

Legal Disclaimer

The information given in this document shall in no event be regarded as a guarantee of conditions or characteristics. With respect to any examples or hints given herein, any typical values stated herein and/or any information regarding the application of the device, Infineon Technologies hereby disclaims any and all warranties and liabilities of any kind, including without limitation, warranties of non-infringement of intellectual property rights of any third party.

Information

For further information on technology, delivery terms and conditions and prices, please contact the nearest Infineon Technologies Office (www.infineon.com).

Warnings

Due to technical requirements, components may contain dangerous substances. For information on the types in question, please contact the nearest Infineon Technologies Office.

Infineon Technologies components may be used in life-support devices or systems only with the express written approval of Infineon Technologies, if a failure of such components can reasonably be expected to cause the failure of that life-support device or system or to affect the safety or effectiveness of that device or system. Life support devices or systems are intended to be implanted in the human body or to support and/or maintain and sustain and/or protect human life. If they fail, it is reasonable to assume that the health of the user or other persons may be endangered.