

- NOTES**
1. 本製品は極数によって、ロック形状が変わりますので御注意願います。
THE LOCK SHAPE OF THIS PRODUCT CHANGES ACCORDING TO THE NUMBER OF CIRCUIT.
2~5 CIRCUITS : フリクションロック FRICTION LOCK
6~15 CIRCUITS : インナーポジティブロック INNER POSITIVE LOCK
 2. 材料及び仕上げ(めっき仕様) : TABLE 1,3 参照
MATERIAL AND FINISHES : SEE TABLE 1 AND 3
 3. 製品仕様書 : 5013300000-PS PS 003
PRODUCT SPECIFICATION:
 4. 梱包形態 : SEE SHEET 4
PACKAGING INFORMATION:
 5. 嵌合相手 : 501330 シリーズ
MATES WITH:501330 SERIES
 6. アプリケーション仕様書(コネクタ取扱い説明書) : 5013300000-AS PS 001
APPLICATION SPECIFICATION(CONNECTOR MANUAL):
 7. ソルダーピン及びネイルの平坦度:0.1 MAX.
SOLDER PIN AND NAIL COPLANARITY: 0.1 MAX.
 8. 偶数極に適用
APPLY FOR EVEN CIRCUIT
 9. 金めっき品は2083870000-SD PSD 000の図面を御参照下さい。
PLEASE REFER TO THE DRAWING No 2083870000-SD PSD 000 FOR GOLD PLATING VERSION.

10. 製品番号構成 : 発注番号はTABLE 2,4参照
PRODUCT NUMBER COMPOSITION
ORDER No. : SEE TABLE 2,4

208387 * * * *

極数 CIRCUIT SIZE	ハウジングカラー HOUSING COLOR	製品識別番号 IDENTIFICATION NUMBER
	0:NATURAL(BEIGE) 1:BLACK	9: TIN PLATING

10. TABLE 2

			HOUSING COLOR		
			BLACK	NATURAL(BEIGE)	
6.2	4.0	7.0	208387 0519	208387 0509	5
5.2	3.0	6.0	208387 0419	208387 0409	4
4.2	2.0	5.0	208387 0319	208387 0309	3
3.2	1.0	4.0	208387 0219	208387 0209	2
C	B	A	発注番号 ORDER No.		極数 CIRCUIT SIZE
極数別 寸法 DIMENSION			梱包形態 : エンボスリール PACKAGE:EMBOSSED REEL		

THIS DRAWING CONTAINS INFORMATION THAT IS PROPRIETARY TO MOLEX ELECTRONIC TECHNOLOGIES, LLC AND SHOULD NOT BE USED WITHOUT WRITTEN PERMISSION					
DIMENSION UNITS		SCALE		CURRENT REV DESC:	
mm		NTS			
GENERAL TOLERANCES (UNLESS SPECIFIED)					
ANGULAR TOL ± 3.0°					
4 PLACES ± 0.2		EC NO: 637929		2020/05/20	
3 PLACES ± 0.2		DRWN: AISHIKAWA		2020/05/22	
2 PLACES ± 0.2		CHK'D: AIDA		2020/05/22	
1 PLACE ± 0.2		APPR: SAKIYAMA		2020/05/22	
0 PLACES ± 0.2		INITIAL REVISION:			
DRAFT WHERE APPLICABLE MUST REMAIN WITHIN DIMENSIONS		DRWN: AISHIKAWA		2019/07/16	
THIRD ANGLE PROJECTION		APPR: SAKIYAMA		2019/10/31	
DRAWING		SERIES		DOCUMENT NUMBER	
A3-SIZE		208387		2083870000-SD	
MATERIAL NUMBER		CUSTOMER		DOC TYPE DOC PART REVISION	
SEE TABLE 2 AND 4		GENERAL		PSD 001 B	
SHEET NUMBER		1 OF 5			

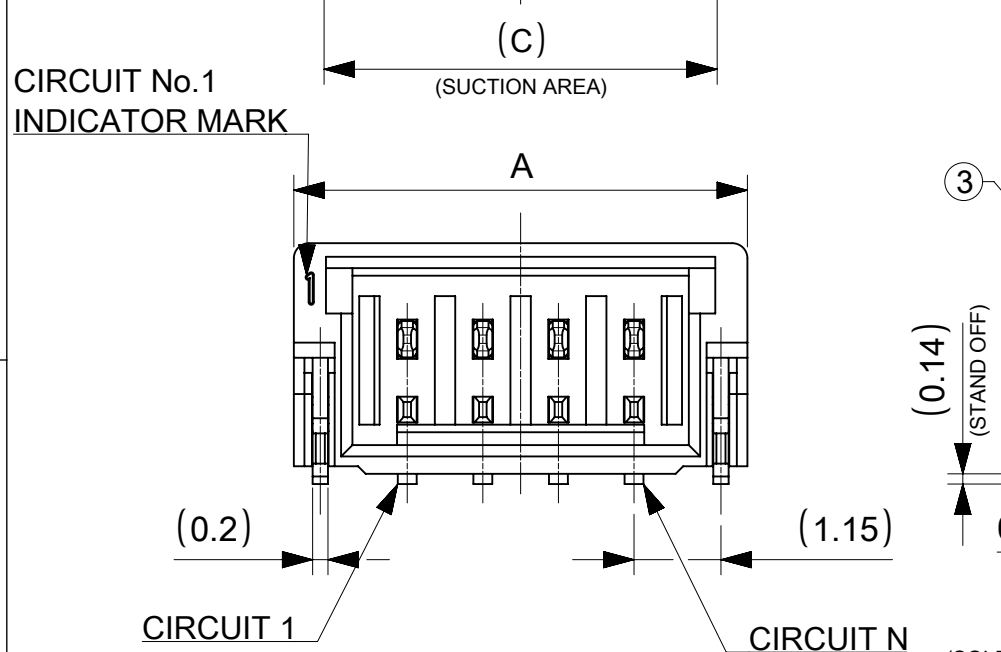
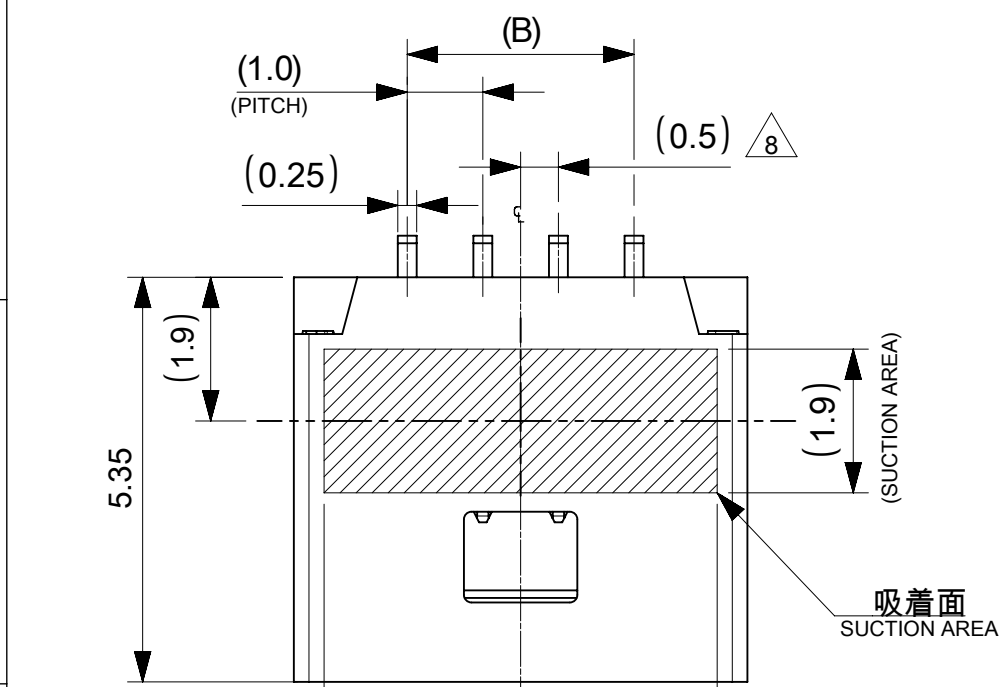
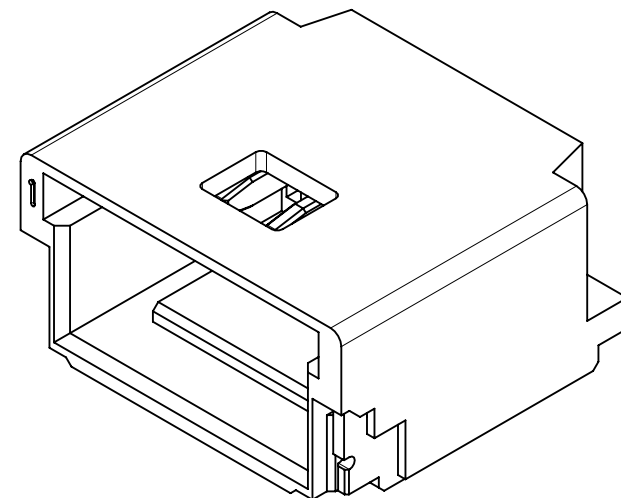

2. TABLE 1

番号 NO.	部品 PART	材質 MATERIAL
①	ウエハー WAFER	ポリアミド(PA), ガラス充填, UL94V-0, LOW HALOGEN, 色 : SEE TABLE 2 POLYAMIDE(PA), GLASS FILLED, UL94V-0, LOW HALOGEN, COLOR : SEE TABLE 2
②	ソルダーピン SOLDER PIN	リン青銅 PHOSPHOR BRONZE
		接点部 CONTACT AREA
		テール部 TAIL AREA
③	ネイル NAIL	下地めっき UNDER PLATING
		黄銅 BRASS
		テール部 TAIL AREA
		下地めっき UNDER PLATING
		錫めっき : 1.0 MICRO-METER MIN MATTE TIN PLATING
		ニッケルめっき : 1.0 MICRO-METER MIN NICKEL PLATING
		錫めっき : 1.0 MICRO-METER MIN MATTE TIN PLATING
		ニッケルめっき : 1.0 MICRO-METER MIN NICKEL PLATING

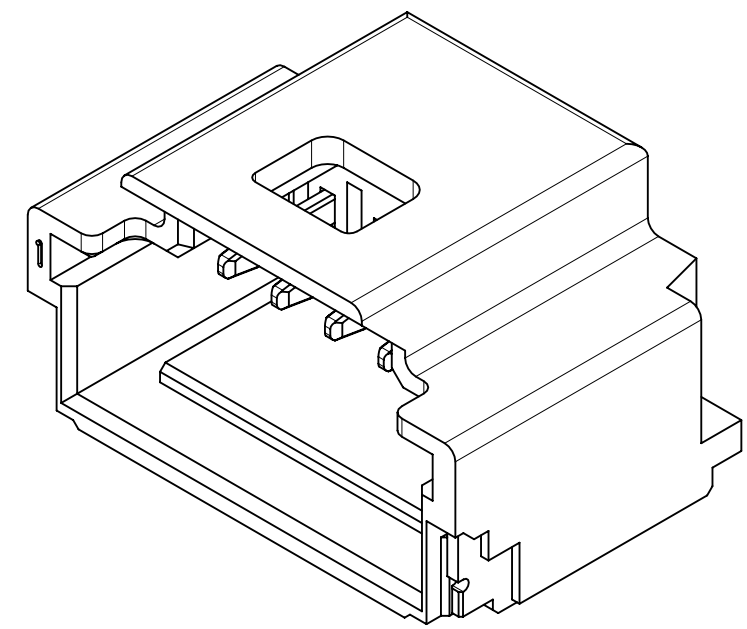
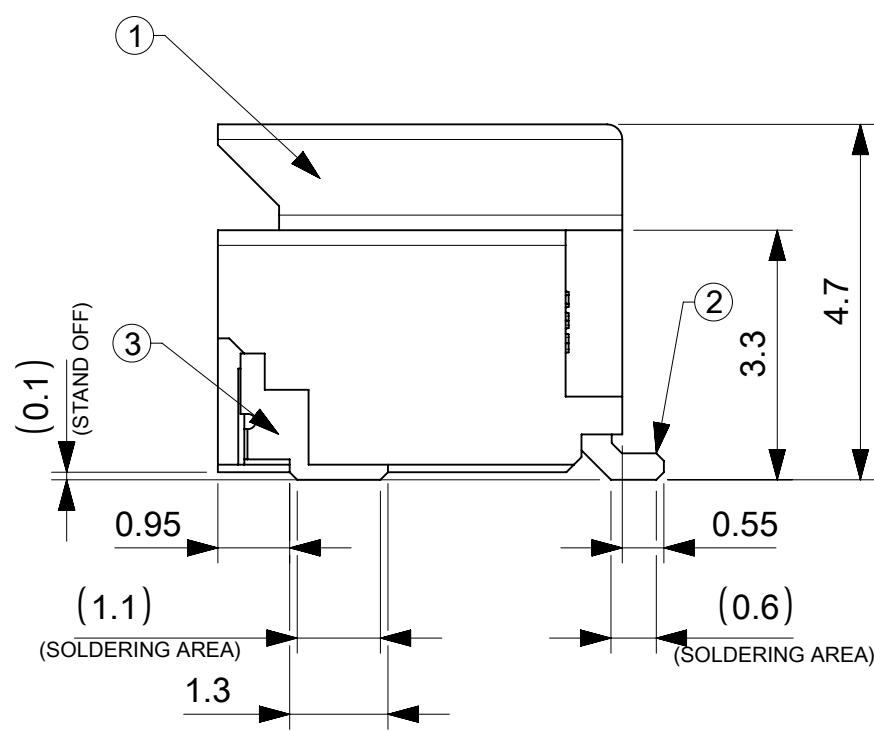
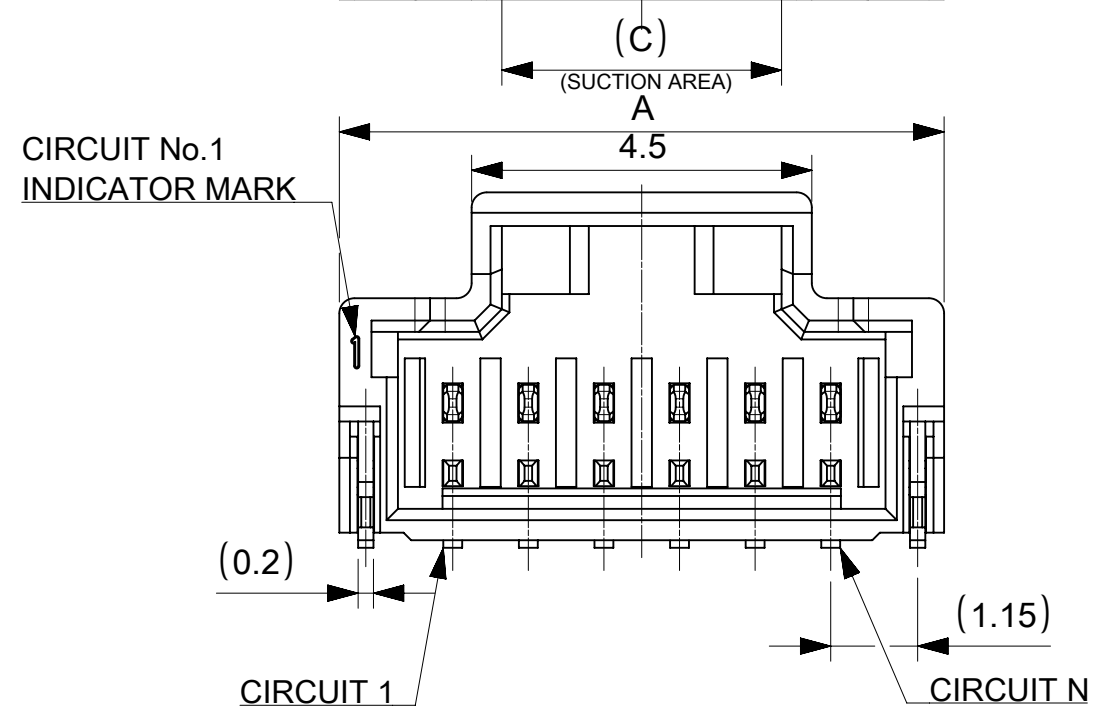
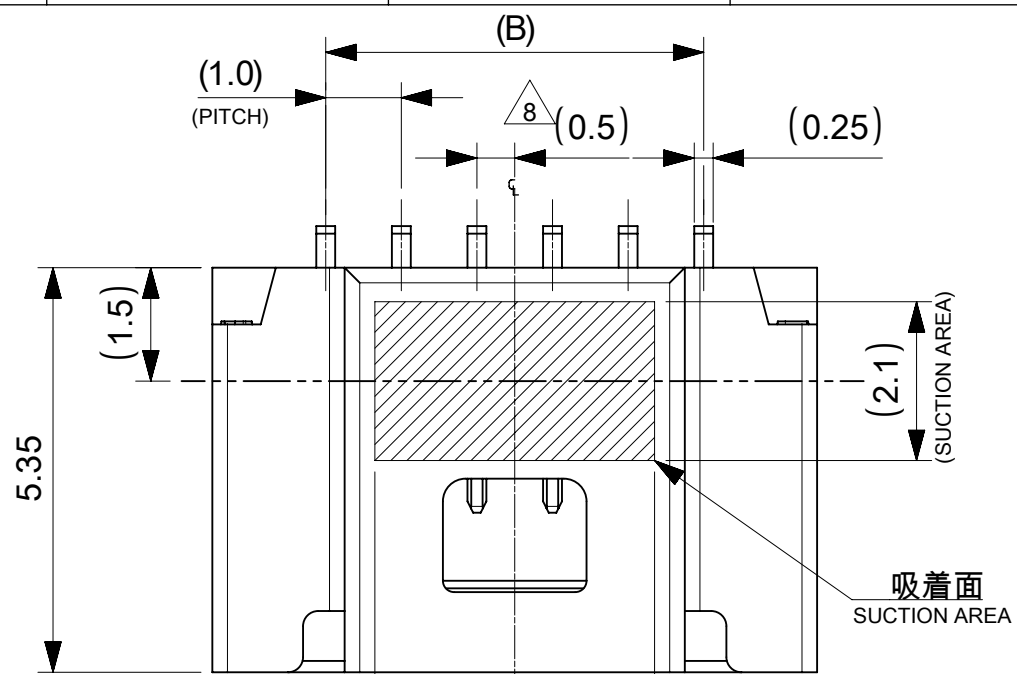

TABLE 3

TABLE 4

			HOUSING COLOR		
			BLACK	NATURAL(BEIGE)	
12.7	14.0	17.0	208387 1519	208387 1509	15
11.7	13.0	16.0	1419	1409	14
10.7	12.0	15.0	1319	1309	13
9.7	11.0	14.0	1219	1209	12
8.7	10.0	13.0	1119	1109	11
7.7	9.0	12.0	1019	1009	10
6.7	8.0	11.0	0919	0909	9
5.7	7.0	10.0	0819	0809	8
4.7	6.0	9.0	0719	0709	7
3.7	5.0	8.0	208387 0619	208387 0609	6
C	B	A	発注番号 ORDER No.		極数
極数別寸法 DIMENSION			梱包形態:エンボスリール PACKAGE:EMBOSSED REEL		CIRCUIT SIZE

番号 NO.	部品 PART	材質 MATERIAL	
①	ウエハー WAFER	ポリアミド(PA), ガラス充填, UL94V-0, LOW HALOGEN, 色: SEE TABLE 2 POLYAMIDE(PA), GLASS FILLED, UL94V-0, LOW HALOGEN, COLOR: SEE TABLE 2	
②	ソルダーピン SOLDER PIN	リン青銅 PHOSPHOR BRONZE	
		接点部 CONTACT AREA	錫めっき: 1.0 MICRO-METER MIN MATTE TIN PLATING
		テール部 TAIL AREA	
	下地めっき UNDER PLATING	ニッケルめっき: 1.0 MICRO-METER MIN NICKEL PLATING	
③	ネイル NAIL	黄銅 BRASS	
		テール部 TAIL AREA	錫めっき: 1.0 MICRO-METER MIN MATTE TIN PLATING
		下地めっき UNDER PLATING	ニッケルめっき: 1.0 MICRO-METER MIN NICKEL PLATING

THIS DRAWING CONTAINS INFORMATION THAT IS PROPRIETARY TO MOLEX ELECTRONIC TECHNOLOGIES, LLC AND SHOULD NOT BE USED WITHOUT WRITTEN PERMISSION

DIMENSION UNITS	SCALE	CURRENT REV DESC:	molex		
mm	NTS				
GENERAL TOLERANCES (UNLESS SPECIFIED)			PICO-CLASP 1.0 W/B SINGLE ROW R/A SMT INNER LOCK TIN PLATING LOW HALOGEN		
ANGULAR TOL	± 3.0°	EC NO: 637929	PRODUCT CUSTOMER DRAWING		
4 PLACES	± 0.2	DRWN: AISHIKAWA 2020/05/20	DOCUMENT NUMBER		
3 PLACES	± 0.2	CHK'D: AIDA 2020/05/22	DOC TYPE DOC PART REVISION		
2 PLACES	± 0.2	APPR: SAKIYAMA 2020/05/22	2083870000-SD PSD 001 B		
1 PLACE	± 0.2	INITIAL REVISION:			
0 PLACES	± 0.2	DRWN: AISHIKAWA 2019/07/16			
DRAFT WHERE APPLICABLE MUST REMAIN WITHIN DIMENSIONS		APPR: SAKIYAMA 2019/10/31			
THIRD ANGLE PROJECTION		DRAWING	SERIES	MATERIAL NUMBER	CUSTOMER
A3-SIZE		208387	SEE TABLE 2 AND 4	GENERAL	SHEET NUMBER
					2 OF 5

5 嵌合相手 : 501330シリーズ
MATE WITH : 501330 SERIES

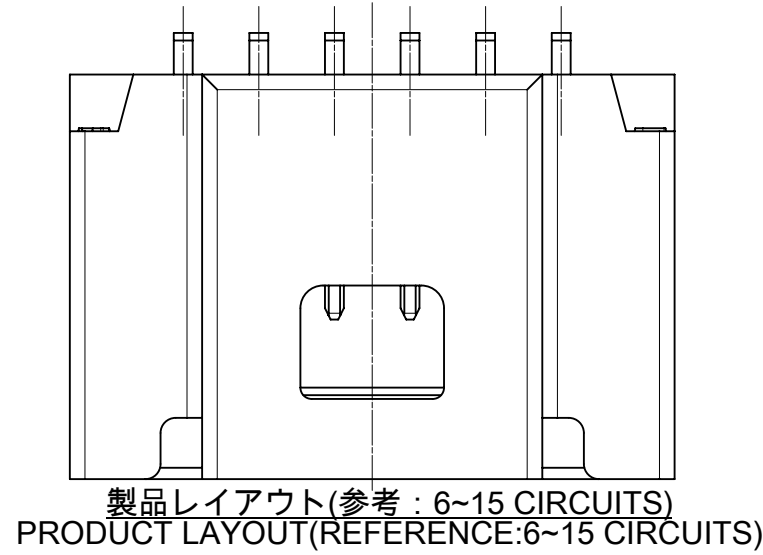

(0.9)
DISTANCE FROM CONNECTOR
OUT-LINE TO TERMINAL PAD

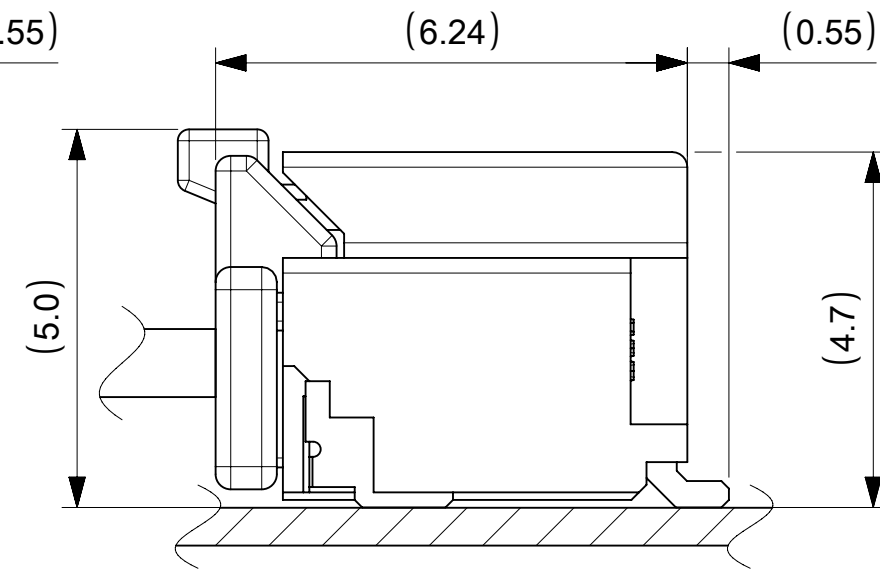
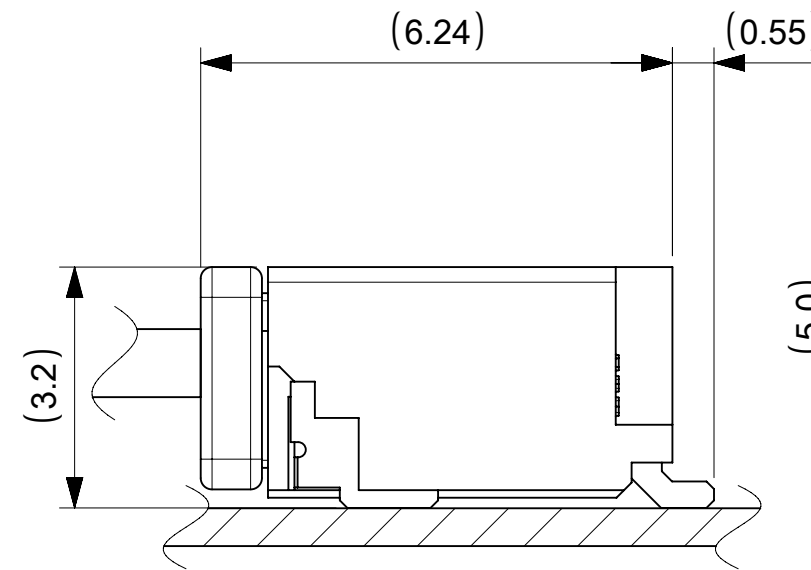
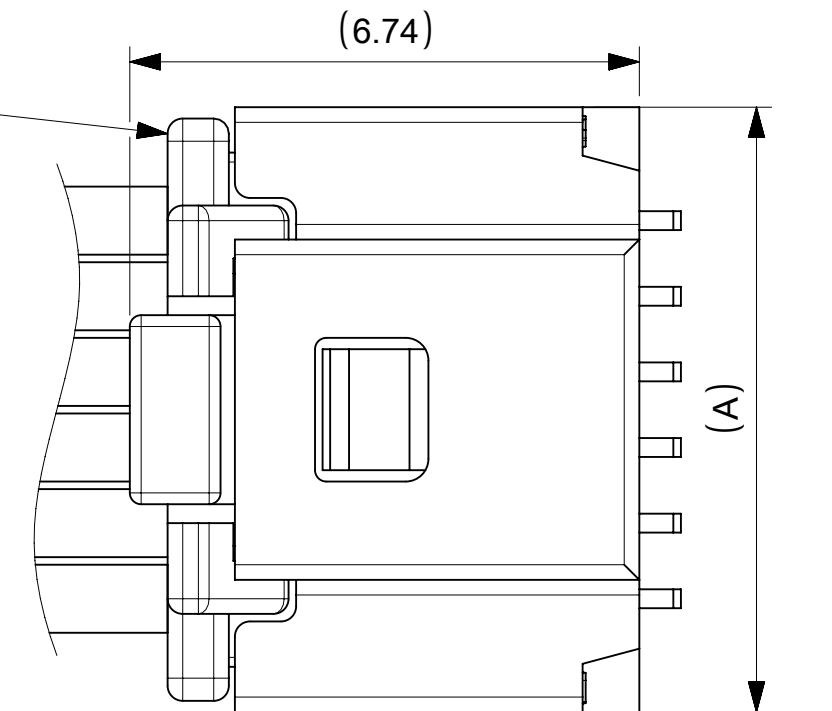
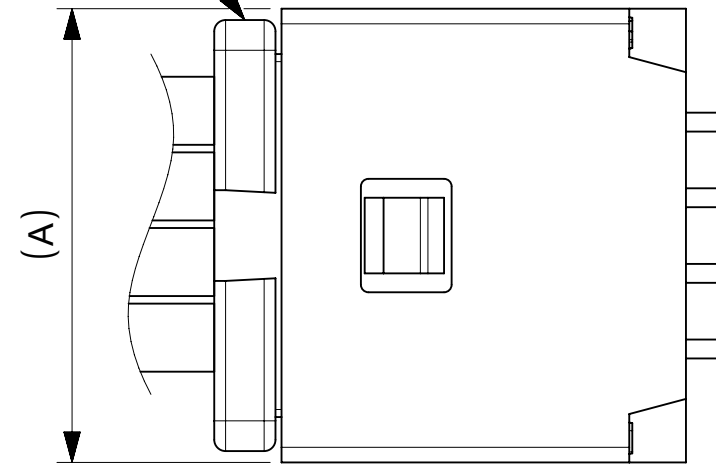
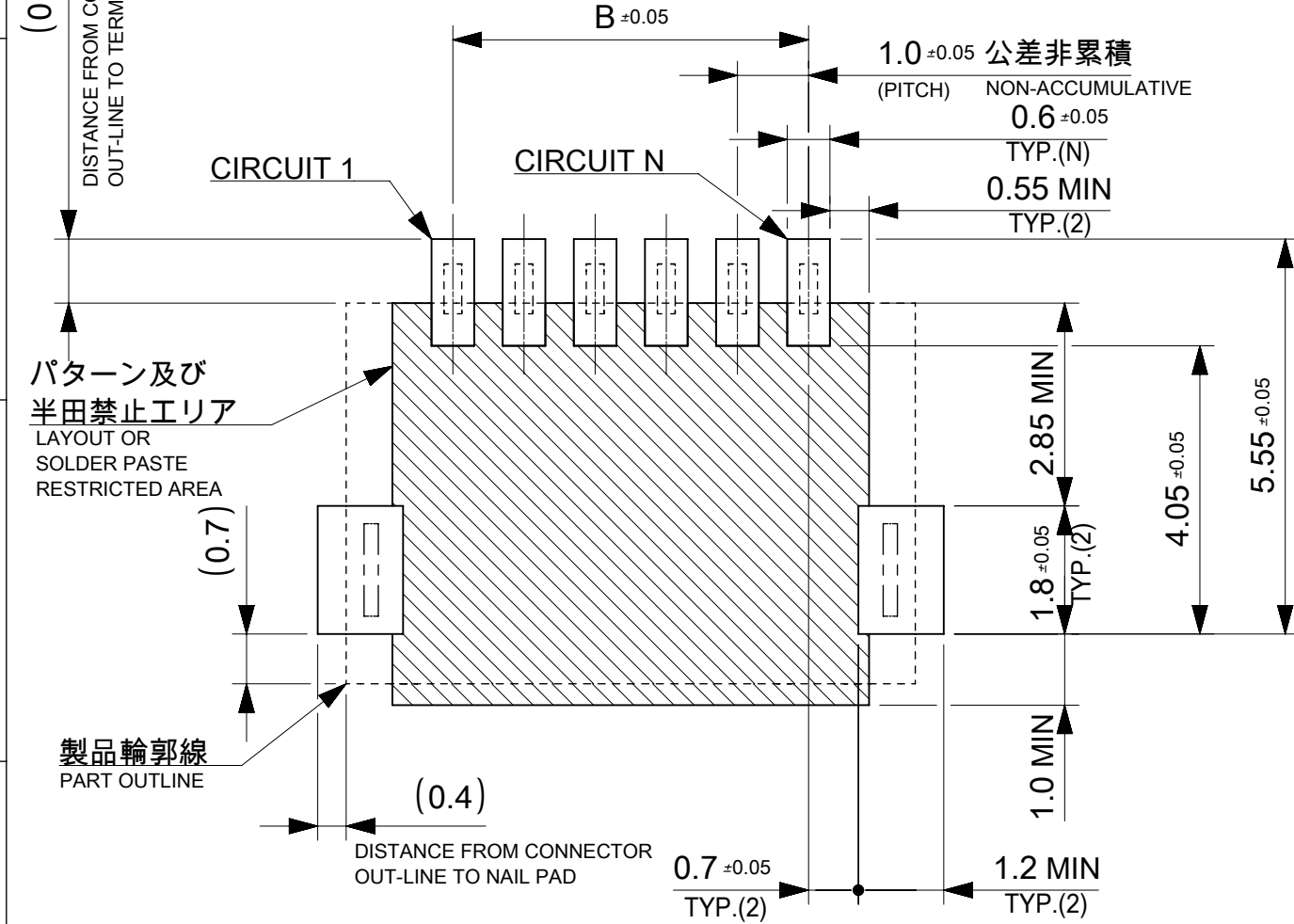

a) 2~5 CIRCUITS

b) 6~15 CIRCUITS

嵌合図
MATED CONNECTORS

推奨基板レイアウト(全極数適応) : 実装面側
(参考 : 基板厚 1.0mm, メタルマスク厚さ 0.12mm, マスク開口率100%)

POLARIZED RECOMMENDED PCB LAYOUT(APPLY TO ALL CIRCUITS) : COMPONENT SIDE
(REFERENCE: PCB THICKNESS 1.0mm, STENCIL THICKNESS 0.12mm, APERTURE RATIO 100%)

:パターン禁止エリア
RESTRICTED AREA
NO PCB COMPONENTS ALLOWED

THIS DRAWING CONTAINS INFORMATION THAT IS PROPRIETARY TO MOLEX ELECTRONIC TECHNOLOGIES, LLC AND SHOULD NOT BE USED WITHOUT WRITTEN PERMISSION		CURRENT REV DESC:		molex	
DIMENSION UNITS	SCALE				
mm	NTS			PICO-CLASP 1.0 W/B SINGLE ROW R/A SMT INNER LOCK TIN PLATING LOW HALOGEN	
GENERAL TOLERANCES (UNLESS SPECIFIED)				PRODUCT CUSTOMER DRAWING	
ANGULAR TOL	± 3.0 °			DOCUMENT NUMBER	
4 PLACES	± 0.2	EC NO: 637929	2020/05/20	2083870000-SD	
3 PLACES	± 0.2	DRWN: AISHIKAWA	2020/05/22	DOC TYPE	DOC PART
2 PLACES	± 0.2	CHK'D: AIDA	2020/05/22	PSD	001
1 PLACE	± 0.2	APPR: SAKIYAMA	2020/05/22	REVISION	
0 PLACES	± 0.2	INITIAL REVISION:		B	
DRAFT WHERE APPLICABLE MUST REMAIN WITHIN DIMENSIONS		DRWN: AISHIKAWA	2019/07/16	SHEET NUMBER	
THIRD ANGLE PROJECTION		APPR: SAKIYAMA	2019/10/31	3 OF 5	
DRAWING		SERIES	MATERIAL NUMBER	CUSTOMER	
A3-SIZE		208387	SEE TABLE 2 AND 4	GENERAL	

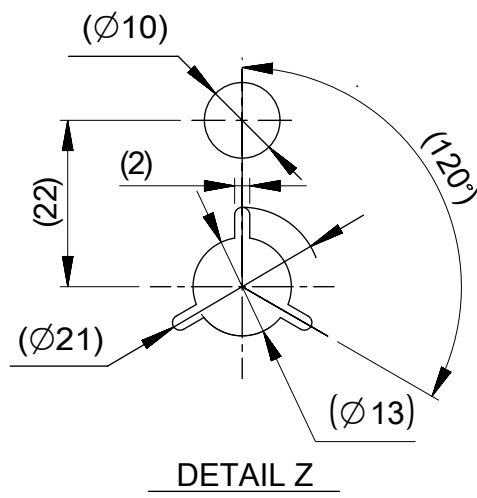
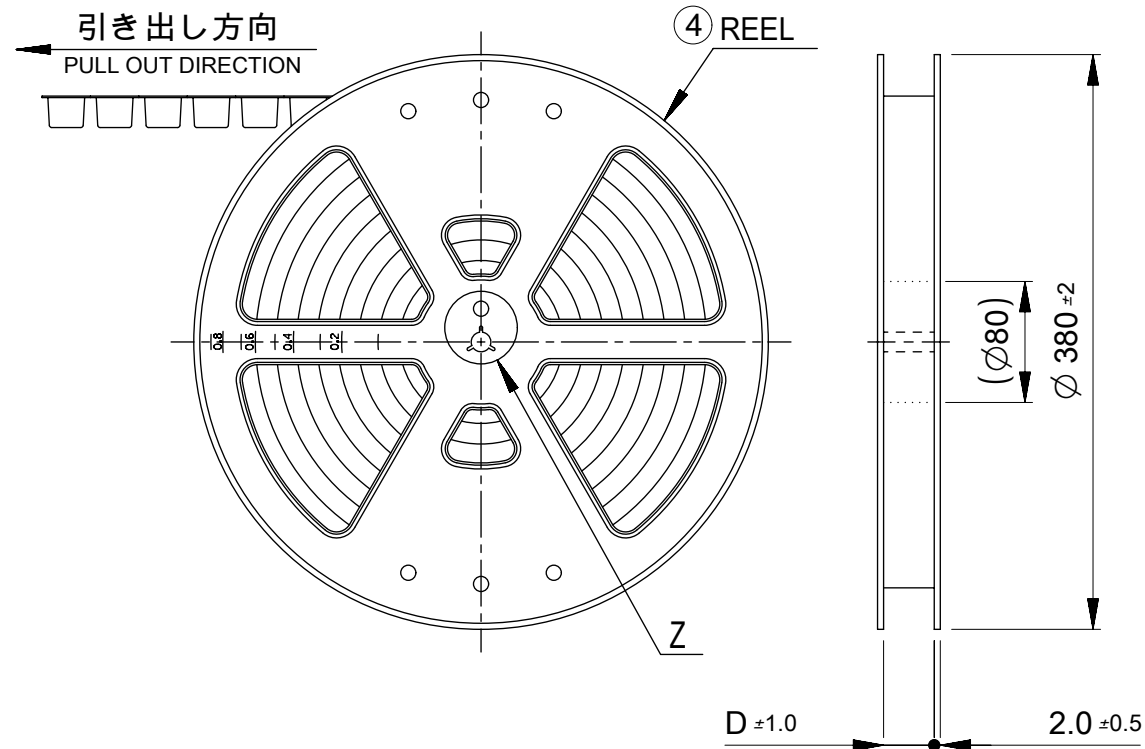

NOTES

10. 梱包数量
 2-5 CIRCUIT: 1700個/リール
 6-15 CIRCUIT: 1300個/リール
 NUMBER OF CONNECTORS
 2-5 CIRCUIT : 1700 PIECES/REEL
 6-15 CIRCUIT : 1300 PIECES/REEL

11. リードテープ長さ
 LEAD TAPE LENGTH

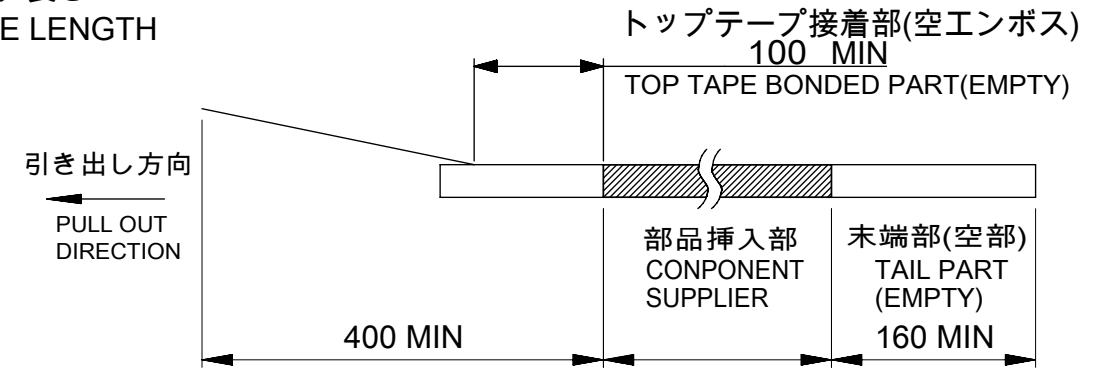

12. トップテープの剥離強度はIEC60286-3に準拠。
 TOP TAPE PEELING FORCE IS DEFINED BY IEC60286-3.
 13. 梱包仕様書 : 2083879200-SPK PS 200
 PACKAGE SPECIFICATION:

33.4	15
	14
	13
25.4	12
	11
	10
	9
	8
	7
17.5	6
	5
	4
	3
D	極数 CIRCUIT SIZE

THIS DRAWING CONTAINS INFORMATION THAT IS PROPRIETARY TO MOLEX ELECTRONIC TECHNOLOGIES, LLC AND SHOULD NOT BE USED WITHOUT WRITTEN PERMISSION		CURRENT REV DESC:		molex	
DIMENSION UNITS	SCALE	EC NO: 637929			
mm	NTS	DRWN: AISHIKAWA 2020/05/20		SINGLE ROW R/A SMT INNER LOCK TIN PLATING LOW HALOGEN	
GENERAL TOLERANCES (UNLESS SPECIFIED)		CHK'D: AIDA 2020/05/22		PRODUCT CUSTOMER DRAWING	
ANGULAR TOL	± 3.0 °	APPR: SAKIYAMA 2020/05/22		DOCUMENT NUMBER	
4 PLACES	± 0.2	INITIAL REVISION:		2083870000-SD	
3 PLACES	± 0.2	DRWN: AISHIKAWA 2019/07/16		DOC TYPE	DOC PART
2 PLACES	± 0.2	APPR: SAKIYAMA 2019/10/31		PSD	001
1 PLACE	± 0.2	MATERIAL NUMBER		CUSTOMER	REVISION
0 PLACES	± 0.2	SEE TABLE 2 AND 4		GENERAL	B
DRAFT WHERE APPLICABLE MUST REMAIN WITHIN DIMENSIONS		THIRD ANGLE PROJECTION	DRAWING	SERIES	SHEET NUMBER
			A3-SIZE	208387	4 OF 5

番号 NO.	部品 PART	材質 MATERIAL
④	リール REEL	ポリスチレン(PS) <リサイクル材を含む> POLYSTYRENE(PS) <RECYCLE MATERIAL CONTAINED>
DOCUMENT STATUS	P1	RELEASE DATE 2020/05/22 02:13:22

2~5 CIRCUITS

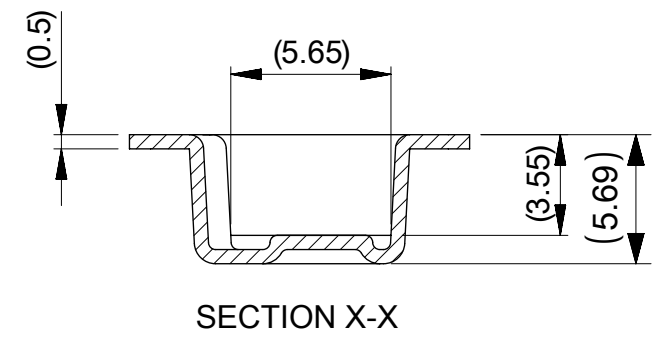
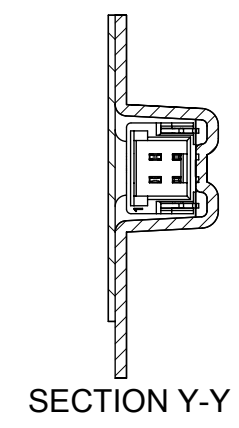
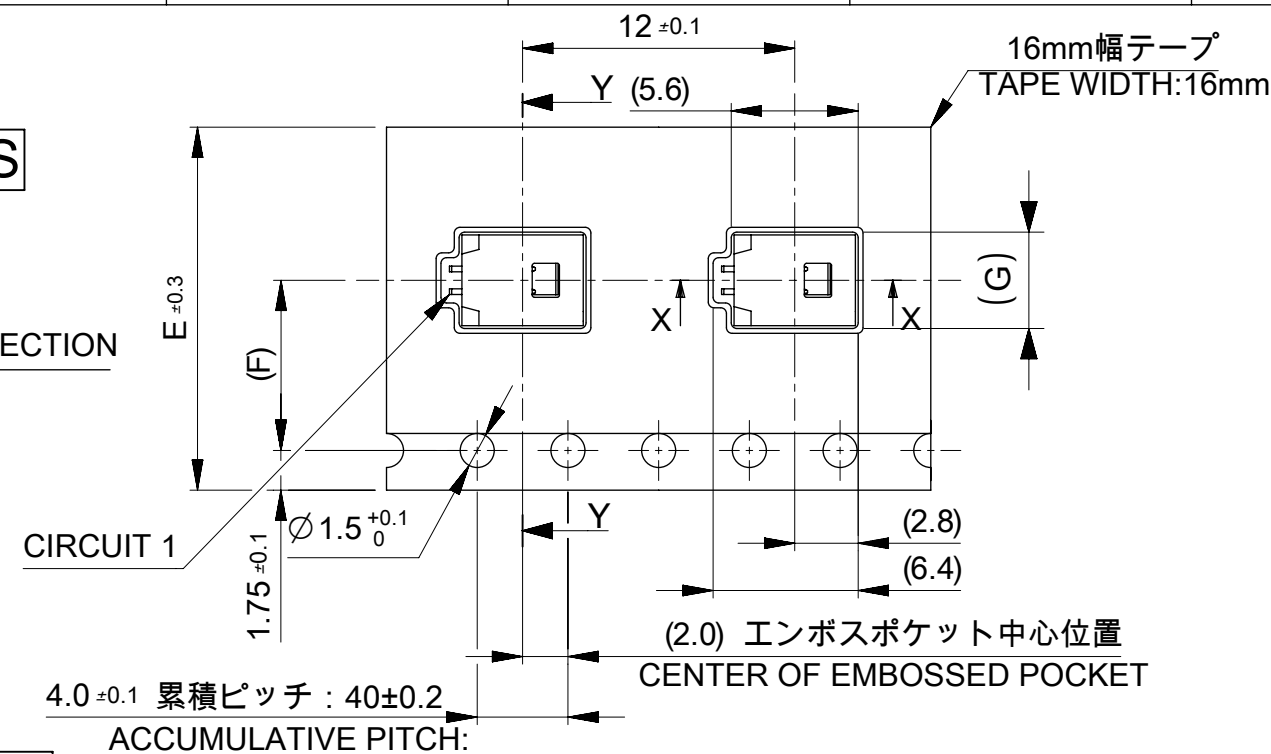

6~15 CIRCUITS

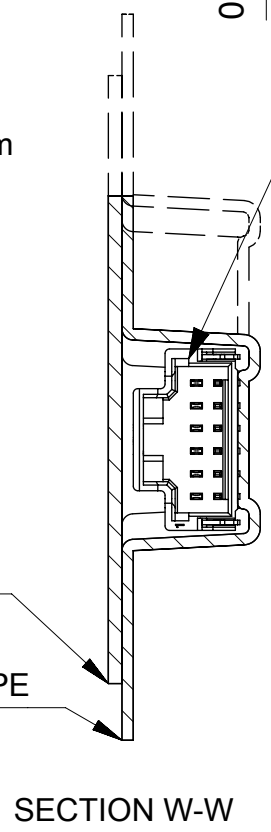
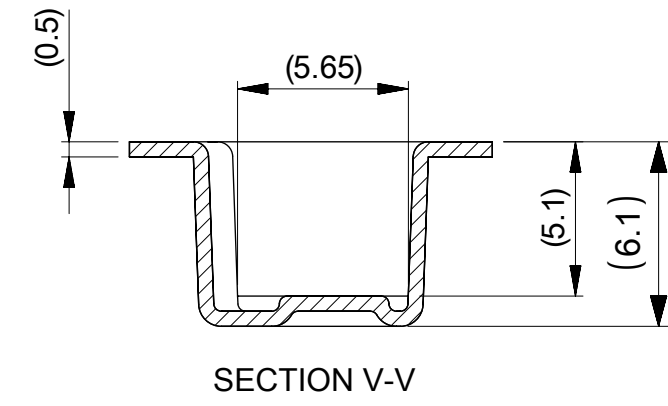
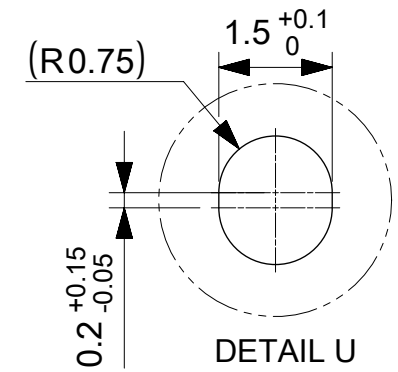
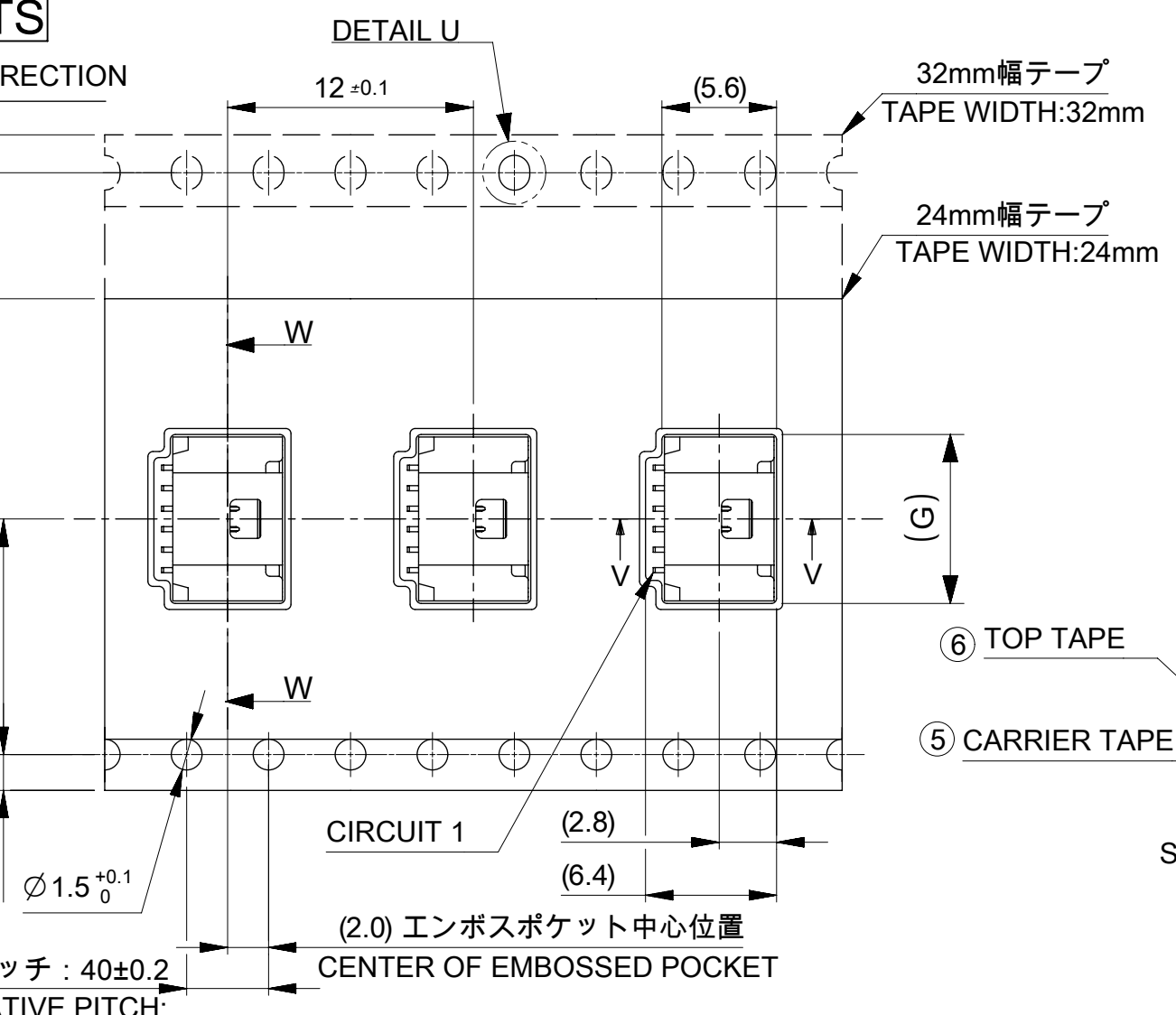

17.3			15
16.3	14.2	32	14
15.3			13
14.3			12
13.3			11
12.3			10
11.3	11.5	24	9
10.3			8
9.3			7
8.3			6
7.3			5
6.3	7.5	16	4
5.3			3
4.3			2
G	コネクタ中心位置 F CENTER OF CONNECTOR	エンボステープ幅 E WIDTH OF TAPE	極数 CIRCUIT SIZE

番号 NO.	部品 PART	材質 MATERIAL
⑤	キャリアテープ CARRIER TAPE	ポリプロピレン(PP)、その他 POLYPROPYLEN(PP), etc
⑥	トップテープ TOP TAPE	ポリエチレン(PE)、その他 POLYETHYLENE(PE), etc

DOCUMENT STATUS	P1	RELEASE DATE	2020/05/22	02:13:22
-----------------	----	--------------	------------	----------

THIS DRAWING CONTAINS INFORMATION THAT IS PROPRIETARY TO MOLEX ELECTRONIC TECHNOLOGIES, LLC AND SHOULD NOT BE USED WITHOUT WRITTEN PERMISSION

DIMENSION UNITS	SCALE	CURRENT REV DESC:	molex		
mm	NTS				
GENERAL TOLERANCES (UNLESS SPECIFIED)			PICO-CLASP 1.0 W/B SINGLE ROW R/A SMT INNER LOCK TIN PLATING LOW HALOGEN		
ANGULAR TOL	± 3.0 °	EC NO: 637929	PRODUCT CUSTOMER DRAWING		
4 PLACES	± 0.2	DRWN: AISHIKAWA	DOCUMENT NUMBER		
3 PLACES	± 0.2	CHK'D: AIDA	DOC TYPE		
2 PLACES	± 0.2	APPR: SAKIYAMA	DOC PART		
1 PLACE	± 0.2	INITIAL REVISION:	REVISION		
0 PLACES	± 0.2	DRWN: AISHIKAWA	2083870000-SD		
		APPR: SAKIYAMA	PSD 001 B		
DRAFT WHERE APPLICABLE MUST REMAIN WITHIN DIMENSIONS	THIRD ANGLE PROJECTION	DRAWING	SERIES	MATERIAL NUMBER	CUSTOMER
		A3-SIZE	208387	SEE TABLE 2 AND 4	GENERAL
					SHEET NUMBER
					5 OF 5