

- NOTES:
1. ALL HOLES REQUIRED REGARDLESS OF NUMBER OF POSITIONS OF CONNECTOR.
 2. MAXIMUM PANEL THICKNESS RECOMMENDED: 0.188 [4.78mm]
 3. HEX NUT & GASKET SHIPPED UNASSEMBLED.
 4. HEX NUT TIGHTENING TORQUE: 8-10 IN/LB
 5. THE DIMENSION DOES NOT INCLUDE THE GASKET.
 6. CURRENT RATING-
5-8 CONTACT: 4.0 AMP
2-4 CONTACT: 5.0 AMP
 7. TEMPERATURE RATING: -40°C TO +85°C (-40°F TO +185°F)
 8. MATERIALS-
PANEL CONNECTOR, HEX NUT, & SPACER: THERMOPLASTIC
GASKET: ELASTOMER
CONTACTS: COPPER ALLOY, GOLD PLATE
PCB: FR-4
HEADER INSULATOR: THERMOPLASTIC, UL94V-0
 9. THIS PRODUCT IS RoHS COMPLIANT.

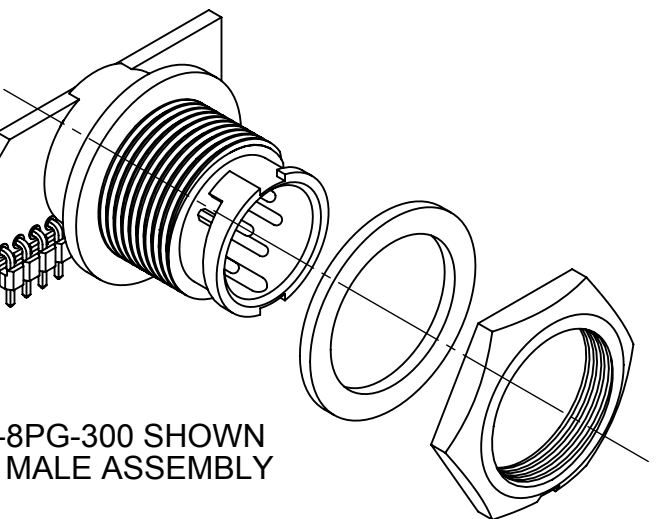
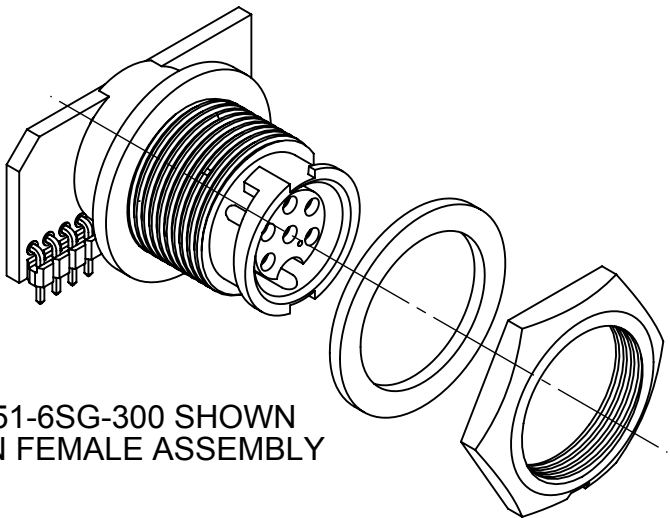
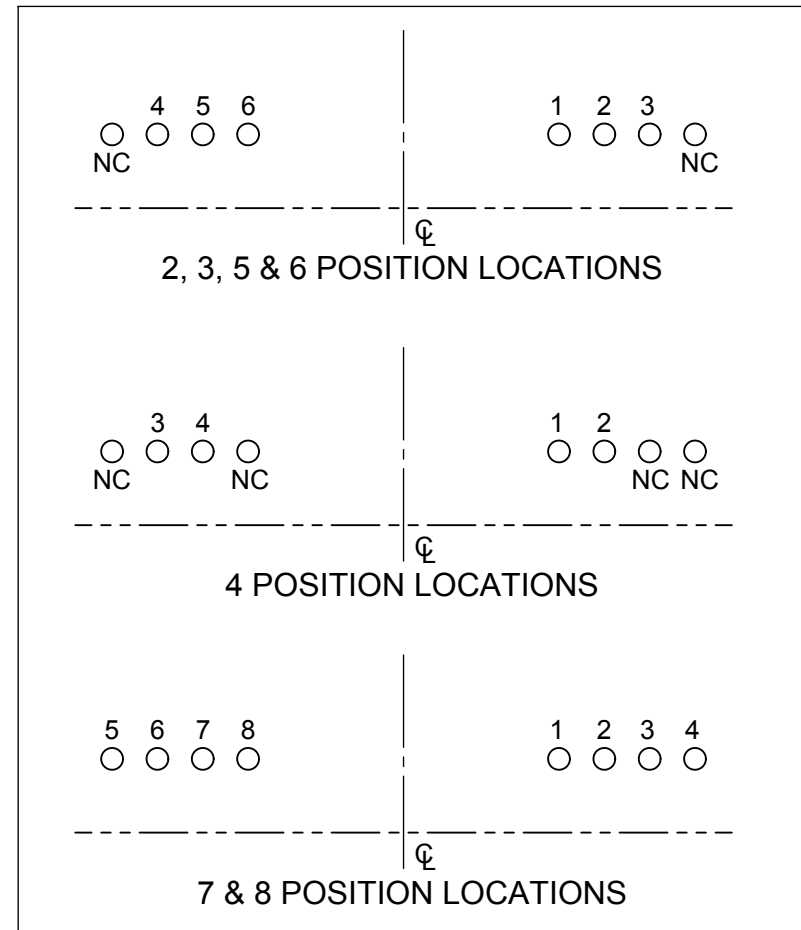
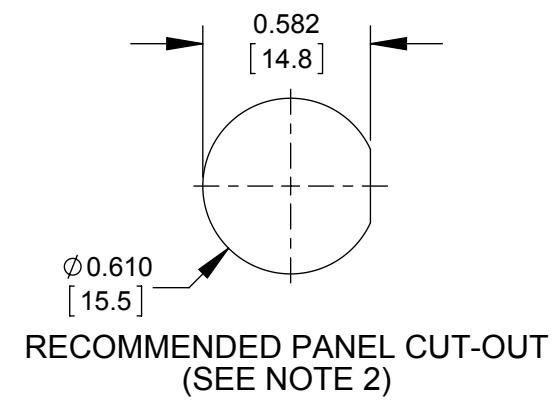
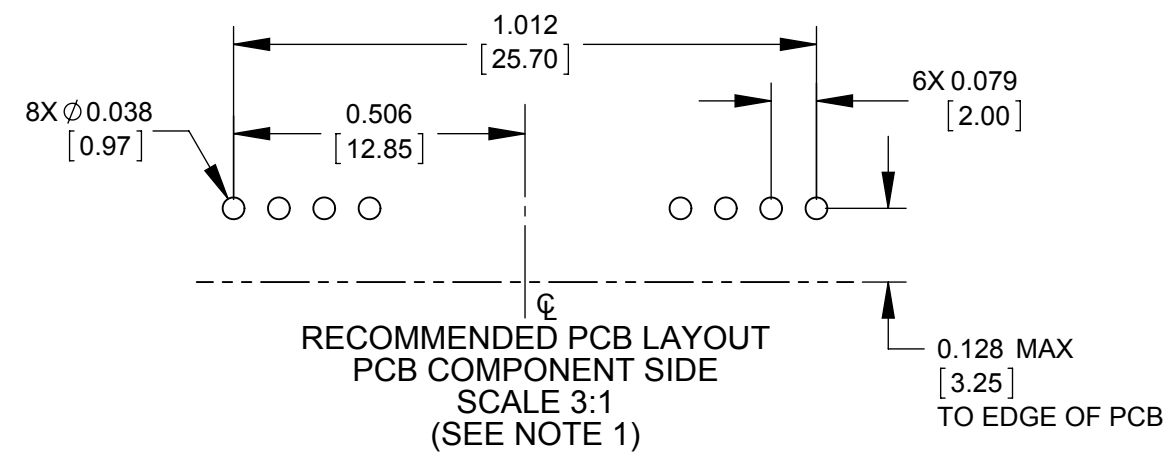
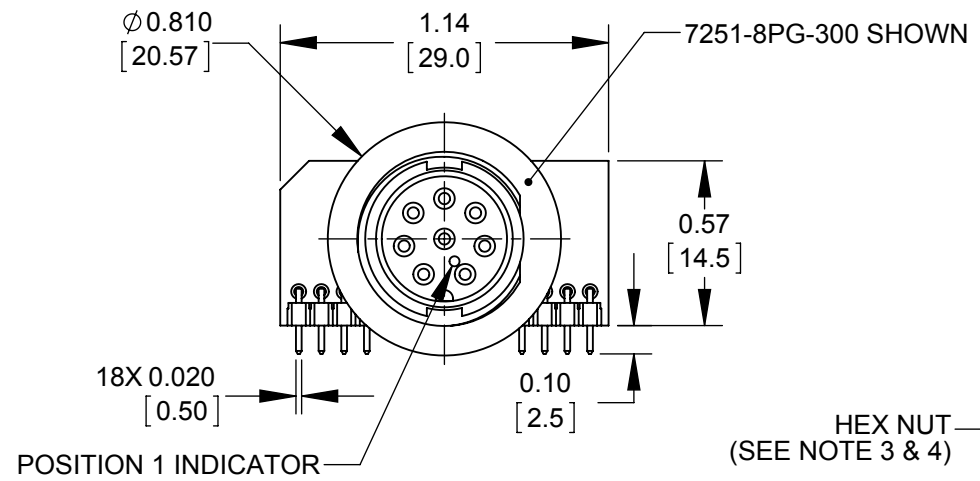

7251 - G - 300

OF CONTACTS
2,3,4,5,6,7,8
(7&8 NOT AVAILABLE IN FEMALE)

GENDER
P - MALE
S - FEMALE

CUSTOMER DRAWING

0C	JGK	11/05/15	UPDATED NOTES.
0B	JGK	9/21/15	UPDATED NOTES.
0A	JGK	8/28/13	DRAWING CREATED PER PROJECT #09001.
REV.	INIT.	DATE	DESCRIPTION
ALL INFORMATION ILLUSTRATED IS THE PROPERTY OF CONXALL CORPORATION. UNAUTHORIZED DUPLICATION OR DISTRIBUTION OF THIS DOCUMENT IS PROHIBITED.			ORIG. DRAWN BY: JGK DATE: 8/26/13 CHECKED BY:
ALL UNITS ARE IN FEET, INCHES, FRACTION OF INCHES AND DECIMALS. UNLESS OTHERWISE SPECIFIED TOLERANCES: 3 PLACE DECIMALS ±.005 ANGLES ±1° FRACTIONS ±1/16			APPROVED BY: SCALE: 3:2 SIZE: B SHEET: 1 OF 1
FILE: - CRITICAL CHARACTERISTIC FLAG PER SPEC. XXXX			TITLE: MINI-CON-X RIGHT ANGLE 2-8 POSITION WIDE PC BOARD STANDARD PRODUCT CUSTOMER: STANDARD PRODUCT PART NUMBER: 7251-__G-300 SERIES REV: 0C

PRELIMINARY

RoHS COMPLIANT

CUSTOMER DRAWING

PART NUMBER: 7251-__G-300 SERIES