

THIS DRAWING IS UNPUBLISHED. RELEASED FOR PUBLICATION  
 © COPYRIGHT BY TYCO ELECTRONICS CORPORATION. ALL RIGHTS RESERVED.

LOC	DIST	REVISIONS					
DF	X0	P	LTR	DESCRIPTION	DATE	DWN	APVD
		C		REVISED PER ECO-07-007761	27APR07	PY	DW

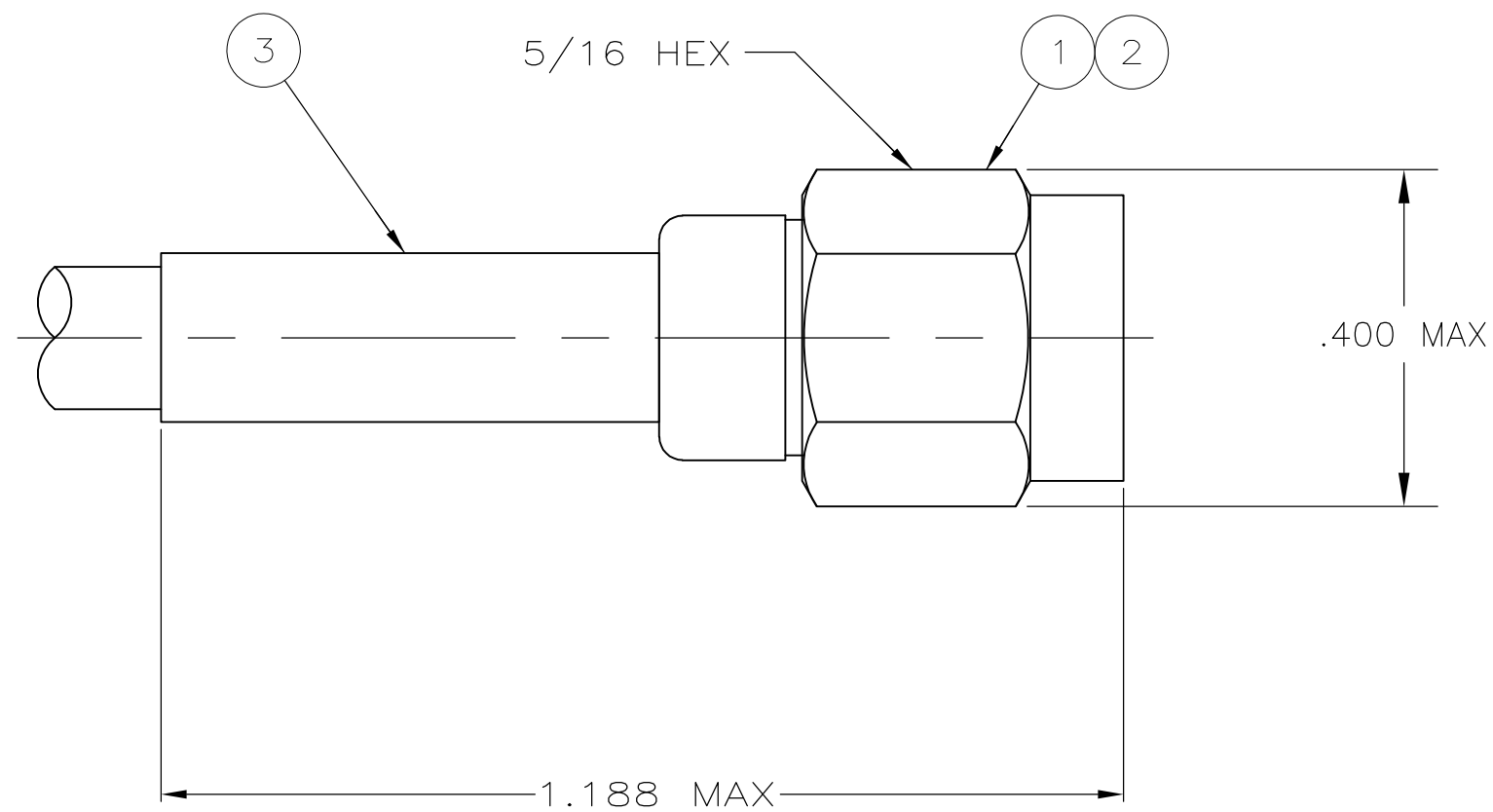

1. CRIMP WITH TOOL: 220061-1

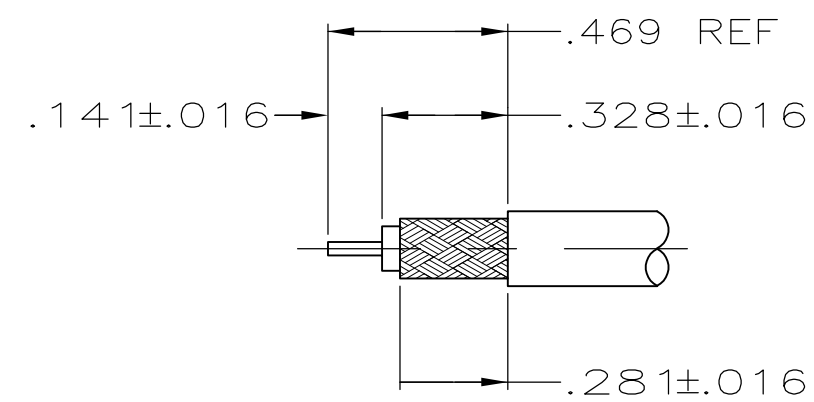

RECOMMENDED STRIP LENGTH  
SCALE: 2:1

LEAD FREE VERSION OF 221117-1	2322	RG-142/U,142A/U,142B/U	225618-5	225540-7	221118-1	5-221117-1
LEAD FREE VERSION OF 221117-2	9161	RG-188/U,188A/U,174/U,316/U	9-50285-0	225540-8	221118-2	221117-4
	OBSOLETE	MOTOROLA C01, RG-188/U DBL BRAID CABLE	50285-8	225540-8	221118-2	221117-3
	9161	RG-188/U,188A/U,174/U,316/U	50285-7	225540-8	221118-2	221117-2
	2322	RG-142/U,142A/U,142B/U	225618-3	225540-7	221118-1	221117-1
IS SHEET		CABLE SIZE	③ FERRULE QTY = 1	② CONTACT QTY = 1	① PLUG ASSY QTY = 1	PART NUMBER

THIS DRAWING IS A CONTROLLED DOCUMENT.

DWN	C.C.THOMAS	10-20-03
CHK	F.BLASICK	10-20-03
APVD	-	-
NAME	Tyco Electronics Corporation Harrisburg, PA 17105-3608	
PRODUCT SPEC	108-12027	
APPLICATION SPEC	-	
WEIGHT	.134 OZ	A2 00779 C=221117
CUSTOMER DRAWING	SCALE 5:1	SHEET 1 of 1

PLUG ASSEMBLY  
SERIES SMA