

Ambient Light Sensor and Proximity Sensor with I²C Interface EAAPMST3923A2

Feature

- **ALS**
 - reading proportional to lux
 - indoor light source flicker noise rejection
 - matching human eye's response (IR rejection)
 - selectable 50/100/200/400/800 lux range
- **PS**
 - narrow band IR spectrum (850nm IRED is recommended)
 - programmable IRED intensity
 - 100mA or 200mA pulsed driving current
 - various periodic sleep time between each measurement
- **Interrupts**
 - independent ALS/PS interrupt thresholds
 - adjustable interrupt persistence
- **Green Power**
 - less than 150µA DC supply current for ALS/PS sensing
 - less than 0.1µA supply current when powered down
- **Easy to Use**
 - SMBus Compatible I²C interface
 - auto register addressing
 - interrupt pin and flags
- **Wide Operating Voltage Range**
 - 1.7V to 3.6V supply for I²C interface
 - 2.3V to 3.6V sensor power supply
- **Wide Operating temperature Range**
 - 40°C to 85°C ambient temperature
- **Size**
 - 3.94mm (L) x2.36mm (W) x1.35mm (H)



General Description

The EAAPMST3923A2 integrates an ambient light sensor (ALS), a proximity sensor (PS), an infrared emitting diode (IRED) driver and an SMBus compatible I²C interface into one chip. The ALS and PS work independently, and communication to the device is accomplished through the fast I²C interface (up to 750 kHz) for easy connection to a microcontroller or embedded controller. A flexible interrupt scheme is provided for minimal microcontroller utilization.

The ambient light sensor (ALS) has 5 working ranges for adapting to different applications and various opto-mechanisms. The ALS reading (output data) is proportional to the ambient light; not extra data manipulation is required. It also has a built-in circuit to reject the 50Hz/60Hz flicker noise caused by indoor light sources. The most distinguished feature of the ALS is that the spectral response is almost the same as human eye's photopic vision due to a well-engineered optional coating on the top of the ambient light detector; thus, light source correction coefficient is not necessary.

The proximity sensor (PS) employs a narrow-band, multi-layer optical coating to suppress most infrared background. Synchronized with the built-in IRED driver, the proximity sensing circuitry adopts track-and-hold (T&H) and correlated double sampling (CDS) techniques to reject non-synchronized infrared signals and electrical DC offset. Each proximity measurement takes about 0.8mS, and various sleep-time in between can be programmed through I²C interface to reduce overall power consumption.

The EAAPMST3923A2 provides a separate pin for level-style interrupt which simplifies and improves system efficiency by eliminating the need to poll a sensor for an ALS or PS readings. An interrupt is generated when the reading of an ALS or PS exceeds either an upper or lower threshold. In addition, a programmable interrupt persistence feature allows the user to determine how many consecutive exceeded readings are necessary to trigger an interrupt. Interrupt threshold and persistence settings are configurable through I²C interface.

Applications

- Display and keypad dimming adjustment and proximity sensing for:
 - Mobile Devices: smart phone, PDA, GPS
 - Computing Devices: laptop PC, notebook
 - Consumer Devices: LCD-TV, digital picture frame, digital camera
- Industrial and medical light and proximity sensing

Package Dimensions

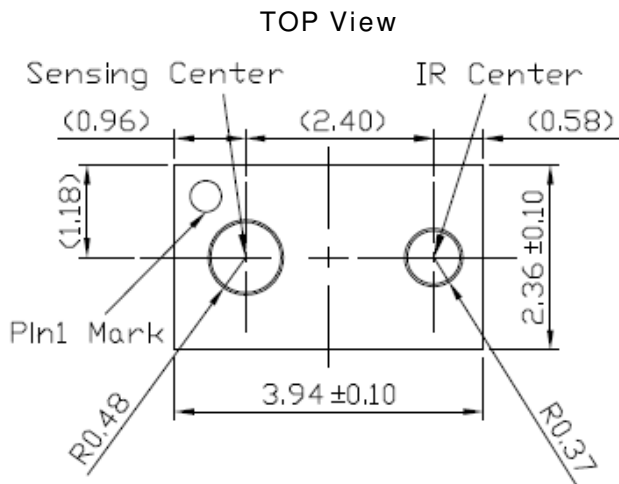

Side View

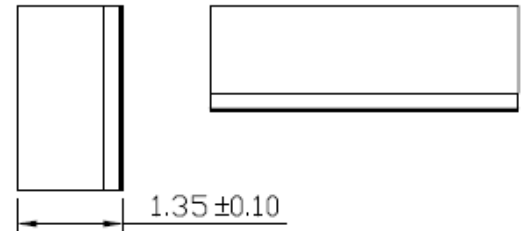

Bottom View

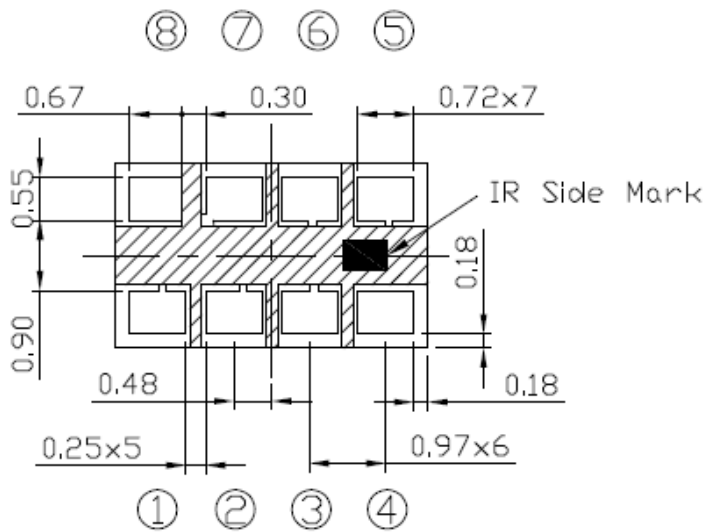

- | | |
|--------|------------|
| ① SDA | ⑤ LEDA |
| ② INT | ⑥ GND/ADDR |
| ③ IRDR | ⑦ SCL |
| ④ LEDK | ⑧ VDD |

Unit: mm
Tolerances: ± 0.1mm

PCB Layout Footprint

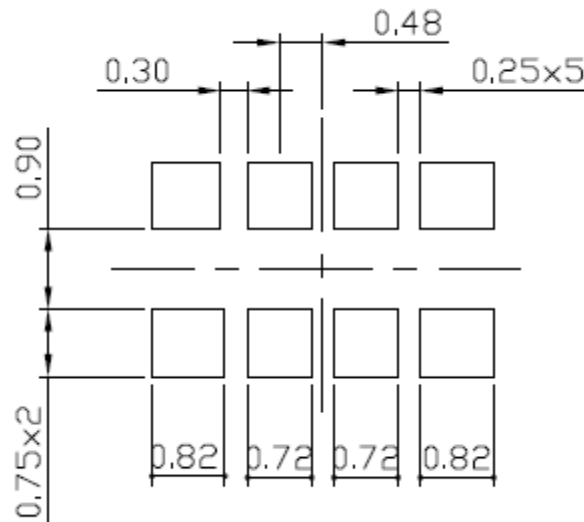

Unit: mm
Tolerances: ± 0.1 mm

Pin Description

Pin No.	Pin name	Pin function
1	SDA	I ² C serial data line
2	INT	Interrupt pin: LO for interrupt alarming. The INT pin is an open drain
3	IRDR	IR LED driver pin connecting to the cathode of the external IR LED
4	LEDK	Cathode of the embedded IR LED, connect to IRDR pin
5	LEDA	Anode of the embedded IR LED, connect to power
6	GND	Ground: The thermal pad is also connected to the GND pin
7	SCL	I ² C serial clock line
8	VDD	Power supply voltage: 2.3V ~ 3.6V

Block Diagram

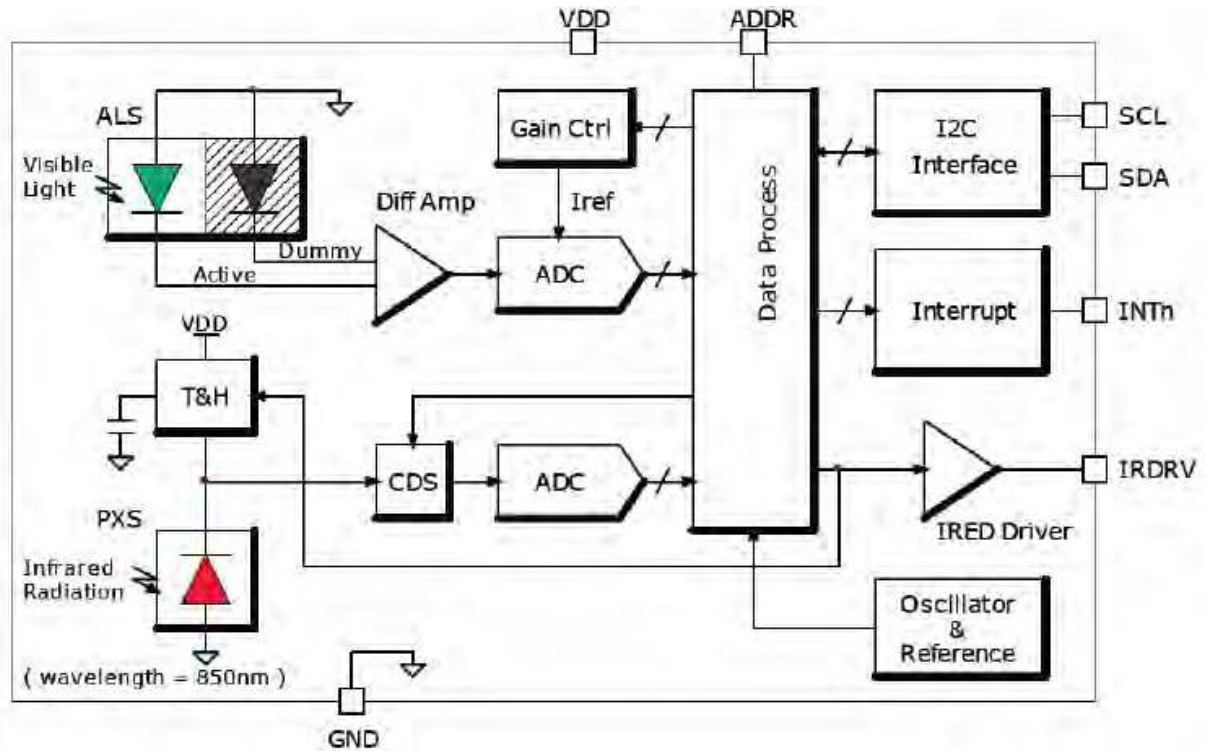

Typical Application Circuit

A typical application for the EAAPMST3923A2 is shown in Figure 1. The device can be tied onto a system's I²C bus together with other I²C compliant devices.

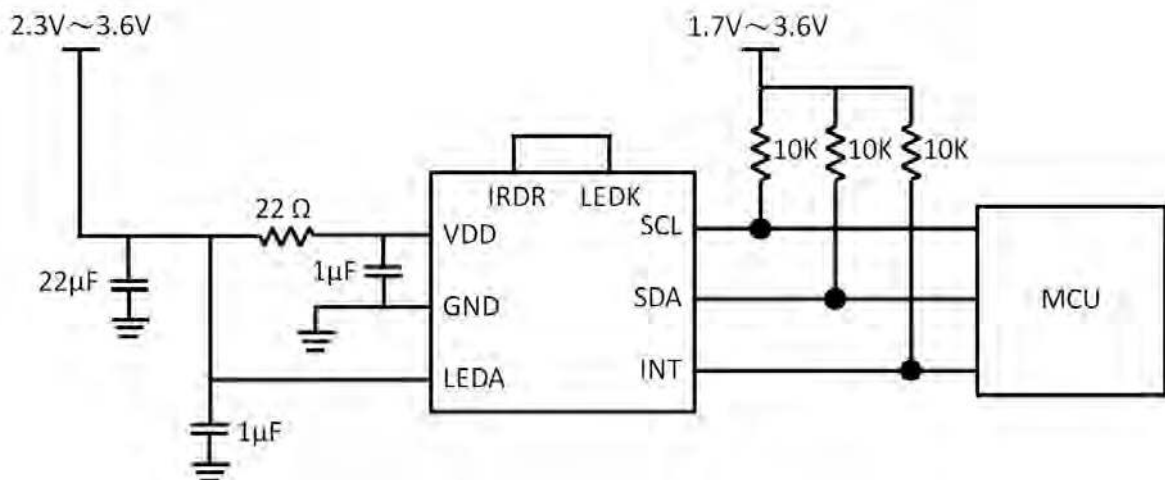

Figure 1. EAAPMST3923A2 typical application circuit

Layout Considerations

The EAAPMST3923A2 is relatively insensitive to layout. Like other I²C devices, it is intended to provide excellent performance even in significantly noisy environments. There are only a few considerations that will ensure best performance. Route the supply and I²C traces as far as possible from all sources of noise.

Absolute Maximum Ratings (T_A= + 25°C)

Parameter	Rating	Unit
VDD supply voltage	4.0	V
I ² C bus voltage (SCL, SDA)	-0.5 to 4.0	V
IRDR pin voltage	5.5	V
ADDR pin voltage	-0.5 to VDD+0.5	V
INT pin voltage	-0.5 to 4.0	V

Caution: Do not operate at or near the maximum ratings listed for extended periods of time. Exposure to such conditions may adversely impact product reliability and result in failures not covered by warranty.

Important Note: All parameters having Min/Max specifications are guaranteed. Typical values are information purposes only. Unless otherwise noted, all tests are the specified temperature and pulsed tests, therefore: T_J= T_C= T_A

Electrical Characteristics (VDD= 3.0V, TA= + 25°C)

Parameter	Descriptions	Conditions	Min.	Typ.	Max.	Unit
V _{DD}	Power supply range		2.3	3.0	3.6	V
SR_V _{DD}	Power-up slew rate	VDD rising edge between 0.4V and 2.3V	0.5	-	-	V/ms
I _{DD_OFF}	Supply current when both ALS and PS is disabled	ALS_EN = 0; PS_EN = 0	-	0.1	0.8	μA
I _{DD_NORM}	Supply current for ALS and PS	ALS_RN = 1; PS_EN = 1	-	110	150	μA
I _{DD_PS_SLP}	Supply current for PS with ALS begin disabled	ALS_EN = 0; PS_EN = 1	-	80	-	μA
I _{DD_ALS}	Supply current for ALS with PS begin disabled	ALS_EN = 1; PS_EN = 0	-	90	-	μA
T _{INTER_ALS}	12-bit ALS conversion time		-	100	-	mS
T _{INTGR_PS}	8-bit PS conversion time		-	0.8	-	mS
COUNT _{ALS_DK}	ALS measurement when there is no light	E _V = 0 lux, Range 4	-	0	-	counts
COUNT _{ALS_FS}	Full scale of ALS output		-	4095	-	counts
COUNT _{ALS_0}	ALS count in Range 0 (low resolution)	E _V = 800 lux, fluorescent lamp	-	4095	-	counts
COUNT _{ALS_1}	ALS count in Range 1	E _V = 400 lux, fluorescent lamp	-	4095	-	counts
COUNT _{ALS_2}	ALS count in Range 2	E _V = 200 lux, fluorescent lamp	-	4095	-	counts
COUNT _{ALS_3}	ALS count in Range 3	E _V = 100 lux, fluorescent lamp	-	4095	-	counts
COUNT _{ALS_4}	ALS count in Range 4 (high resolution)	E _V = 50 lux, fluorescent lamp	-	4095	-	counts
COUNT _{PS_DK}	PS measurement w/o object in path		-	0	-	counts
COUNT _{PS_FS}	Full scale of PS output		-	-	255	counts
t _r	Rise time for IRDR sink current	R _{LOAD} = 15Ω at IRDR, 20% to 80%	-	0.5	-	μS
t _f	Full time for IRDR sink current	R _{LOAD} = 15Ω at IRDR, 80% to 20%	-	0.5	-	μS
f _{I2C}	I ² C clock rate		-	-	750	KHz
V _{I2C}	Supply voltage range for I ² C interface		1.7	-	3.6	V
V _{IL}	SCL and SDA input low voltage		-	-	0.55	V
V _{IH}	SCL and SDA input high voltage		1.25	-	-	V
R _{pull-up}	SDA and SCL system bus pull-up resistor	Maximum is determined by t _r and t _f	-	10	-	KΩ

Note: The I²C bus protocol was developed by Philips (now NXP). For a complete description of the I²C protocol, please review the NXP I²C design specification at <http://www.i2c-bus.org/references/>.

Slave Address

The EAAPMST3923A2 provides the fixed slave address. In following table, it describes the command setting

ADDR	Slave Address	Command Address	Operation
PULL LOW	0x44 (7-bits)	0x88 (8-bits)	Write Command to EAAPMST3923A2
		0x89 (8-bits)	Read Data from EAAPMST3923A2

Register Map

There are eleven 8-bit registers accessible via I²C. Registers 0x01 and 0x02 define the operation mode of the device. Registers 0x03 through 0x07 store the various ALS/PS thresholds which trigger interrupt events. Registers 0x08 through 0x0A store the results of ALS/PS ADC conversions.

REG ADDR	REG NAME	BIT								Default
		7	6	5	4	3	2	1	0	
0x00	Product ID	Product ID Code for Communication Link Test (Write 0)								21h
0x01	CONFIGURE	PS_EN	PS_SLP[2:0]		IRED_DR	ALS_EN	0	0	BCh	
0x02	INTERRUPT	PS_FLAG	PS_PRST[1:0]	0	ALS_FLAG	ALS_PRST[1:0]	INT_CTRL		8Bh	
0x03	PS_LT	PS_LT[7:0]								00h
0x04	PS_HT	PS_HT[7:0]								FFh
0x05	ALS_TH1	ALS_LT[7:0]								00h
0x06	ALS_TH2	ALS_HT[3:0]			ALS_LT[11:8]					F0h
0x07	ALS_TH3	ALS_HT[11:4]								FFh
0x08	PS_DATA	PS_DATA[7:0]								00h
0x09	ALS_DT1	ALS_DATA[7:0]								00h
0x0A	ALS_DT2	0			ALS_DATA[11:8]					00h
0x0B	ALS_RNG	0			ALS_RANGE[2:0]					00h

Register 0x01 (Configure)

Bit #	Access	Name	Function / Operation
7	RW	PS_EN (PS Enable)	When = 0, proximity sensing is disabled. When = 1, continuous proximity sensing is enable. Proximity data will be ready 0.54ms after this bit is set high
6:4	RW	PS_SLP (PS Sleep)	For bits 6:4 = (see the following) 111; sleep time between PS IR LED pulse is 0ms (run continuously) 110; sleep time between PS IR LED pulse is 12.5ms 101; sleep time between PS IR LED pulse is 50ms 100; sleep time between PS IR LED pulse is 75ms 011; sleep time between PS IR LED pulse is 100ms 010; sleep time between PS IR LED pulse is 200ms 001; sleep time between PS IR LED pulse is 400ms 000; sleep time between PS IR LED pulse is 800ms
3	RW	IRDR_DR (PS Drive)	When = 0, IRDR behaves as a pulsed 100mA current sink When = 1, IRDR behaves as a pulsed 200mA current sink
2	RW	ALS_EN (ALS Enable)	When = 0, ALS sensing is disabled. When = 1, continuous ALS sensing is enabled with new data ready every 100mS.
1:0	RW	Unused (write 0)	Unused register bit – write 0

Register 0x02 (Interrupt)

Bit #	Access	Name	Function / Operation
7	FLAG	PS_FLAG (PS Flag)	When = 0, no PS interrupt event has occurred since power-on or last “clear”. When = 1, a PS interrupt event occurred. Clearable by writing “0”.
6:5	RW	PS_PRST (PS Persist)	For bits 6:5 = (see the following) 00; set PS_FLAG if 1 conversion result trips the threshold value 01; set PS_FLAG if 4 conversion result trips the threshold value 10; set PS_FLAG if 8 conversion result trips the threshold value 11; set PS_FLAG if 16 conversion result trips the threshold value
4	RW	Unused (write 0)	Unused register bit – write 0
3	FLAG	ALS_FLAG (ALS FLAG)	When = 0, no ALS interrupt event has occurred since power-on or last “clear”. When = 1, an ALS interrupt event occurred. Clearable by writing “0”.
2:1	RW	ALS_PRST (ALS Persist)	For bits 2:1 = (see the following) 00; Every ALS cycle generates an interrupt. 01; set ALS_FLAG if 4 conversion are outside the set window 10; set ALS_FLAG if 8 conversion are outside the set window 11; set ALS_FLAG if 16 conversion are outside the set window
0	RW	INT_CTRL (Interrupt Control)	When = 0, set INTn pin low if PS_FLAG or ALS_FLAG high (logical OR). When = 1, set INTn pin low if PS_FLAG and ALS_FLAG high (logical AND)

Register 0x03 (PS_LT)

Bit #	Access	Name	Function / Operation
7:0	RW	PS_LT (PS Threshold)	8-bit interrupt low threshold for proximity sensing

Register 0x04 (PS_HT)

Bit #	Access	Name	Function / Operation
7:0	RW	PS_HT (PS Threshold)	8-bit interrupt high threshold for proximity sensing

Register 0x05 (ALS_TH1)

Bit #	Access	Name	Function / Operation
7:0	RW	ALS_LT[7:0] (ALS Low Thr.)	Lower 8 bits (of 12 bits) for ALS low interrupt threshold

Register 0x06 (ALS_TH2)

Bit #	Access	Name	Function / Operation
7:4	RW	ALS_HT[3:0] (ALS High Thr.)	Lower 4 bits (of 12 bits) for ALS high interrupt threshold
3:0	RW	ALS_LT[11:8] (ALS Low Thr.)	Upper 4 bits (of 12 bits) for ALS low interrupt threshold

Register 0x07 (ALS_TH3)

Bit #	Access	Name	Function / Operation
7:0	RW	ALS_HT[11:4] (ALS High Thr.)	Upper 8 bits (of 12 bits) for ALS high interrupt threshold

Register 0x08 (PS_DATA)

Bit #	Access	Name	Function / Operation
7:0	RO	PS_DATA (PS Data)	Result of 8-bit proximity sensor ADC conversion

Register 0x09 (ALS_DT1)

Bit #	Access	Name	Function / Operation
7:0	RO	ALS_DATA (ALS Data)	Lower 8 bits (of 12 bits) from result of ALS sensor conversion

Register 0x0A (ALS_DT2)

Bit #	Access	Name	Function / Operation
7:4	RO	Unused (write 0)	Unused register bit
3:0	RO	ALS_DATA (ALS Data)	Upper 4 bits (of 12 bits) from result of ALS sensor conversion

Register 0x0B (ALS RNG)

Bit #	Access	Name	Function / Operation
7:3	R/W	Unused (write 0)	Unused register bit
2:0	R/W	ALS_RANGE[2:0]	For bits 2:0 = (see the following) 000: ALS is in 800 lux range (0.195 lux / count) 001: ALS is in 400 lux range (0.098 lux / count) 010: ALS is in 200 lux range (0.048 lux / count) 011: ALS is in 100 lux range (0.024 lux / count) 100~111: ALS is in 50 lux range (0.012 lux / count)

Typical Electro-Optical Characteristic Curves (VDD= 3.0V, T_A= + 25°C)

Fig 1. Shutdown current consumption vs. Supply voltage

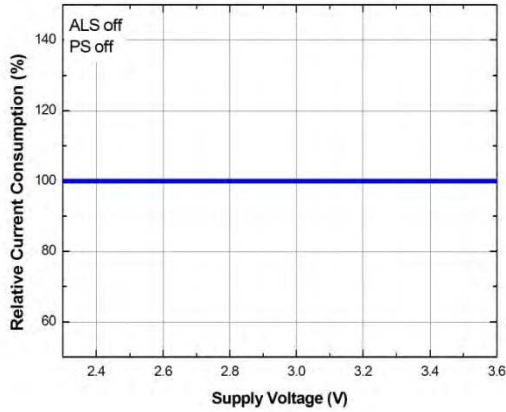

Fig 2. ALS output counts vs. Luminance

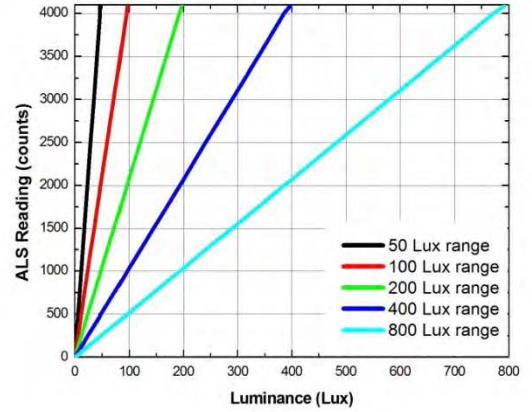

Fig 3. ALS current consumption operating vs. Supply voltage

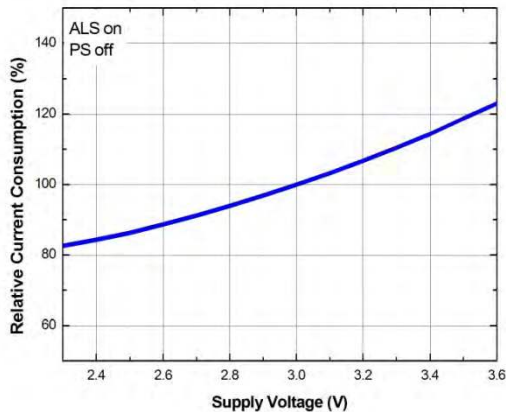

Fig 4. ALS view angle

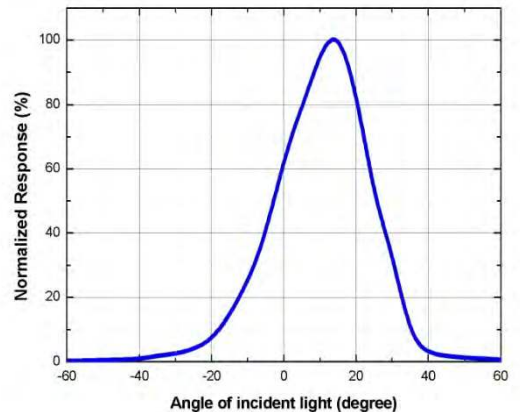

Fig 5. PS current consumption operating vs. Supply voltage

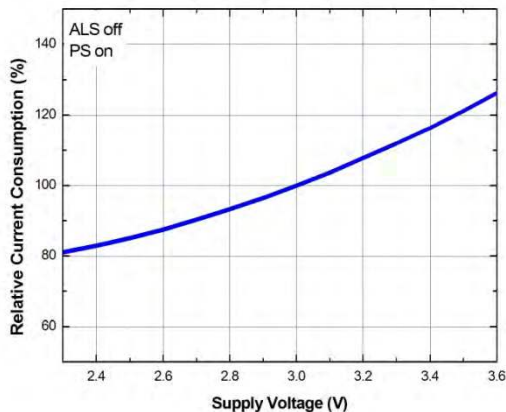
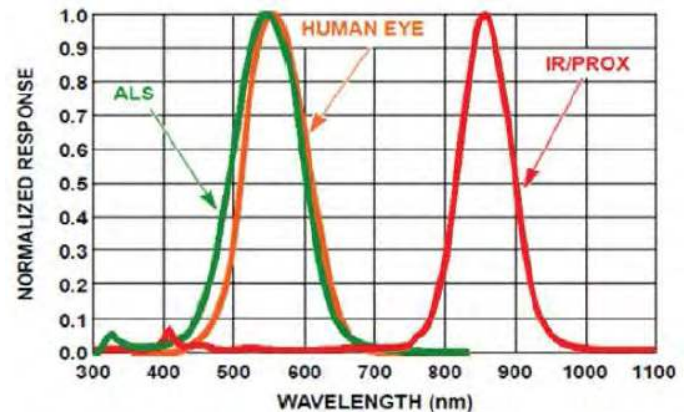

Fig 6. ALS & PS spectral response



Principles of Operation

I²C Read/ Write Register Data

The EAAPMST3923A2's I²C slave address in 8-bit of write address is 0x88, read address is 0x89. Below picture detail the protocol of writing or reading the register data inside the EAAPMST3923A2.

- A : Acknowledge (0)
- NA : Not Acknowledged (1)
- P : Stop Condition
- R : Read (1)
- W : Write (0)
- S : Start Condition
- Sr : Repeat Start
- ... : Continuation of Protocol
- : Mater to Slave
- : Slave to Mater

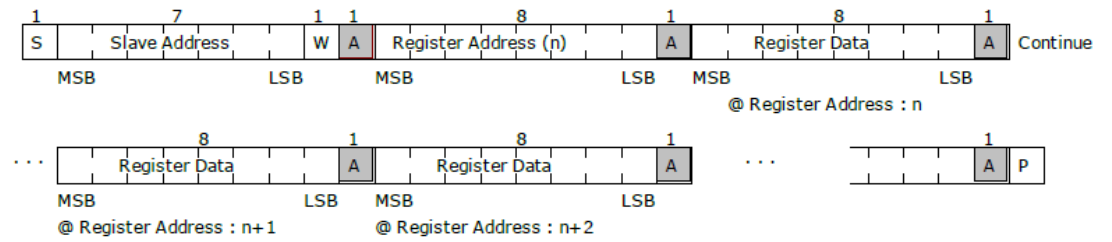

Figure 2. I²C Write-Register-Data Protocol

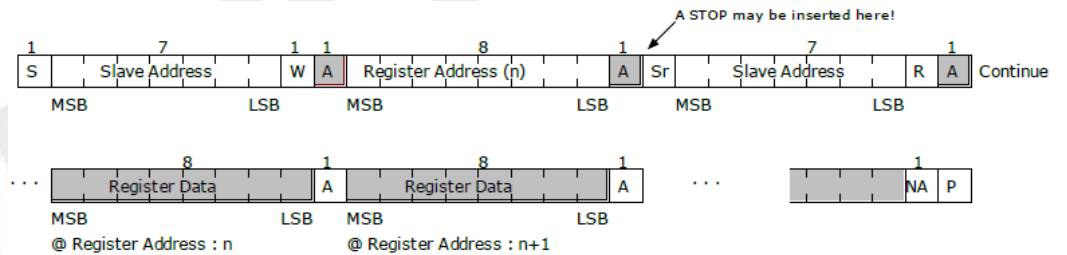

Figure 3. I²C Read-Register-Data Protocol

Ambient Light Sensing

Shown in below picture is the spectral response of EAAPMST3923A2's ambient light sensor which perfectly matches human eye's photopic vision curve. Under the same luminance (lux), the ratio of the ALS reading of an incandescent light source (rich of IR radiation) to that of a fluorescent light sources (no IR radiation) is around 0.99; that means, the EAAPMST3923A2's ALS can be a true lux meter regardless of light sources. The EAAPMST3923A2 is set for ambient light sensing when register bit ALS_EN = 1.

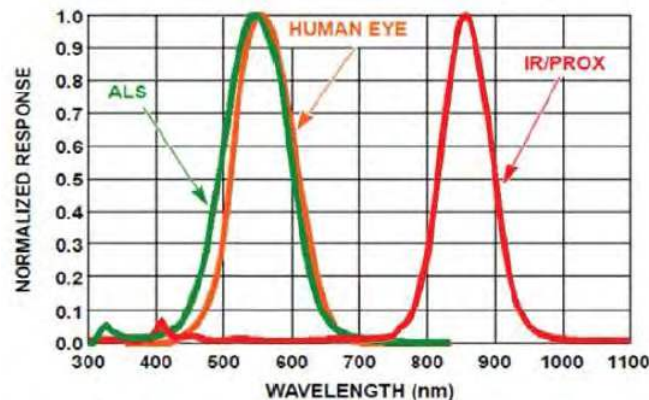

Figure 4. Ambient light spectral response

Proximity Sensing

As illustrated in below picture, an infrared emitter (IRED), driven by the PS circuitry, emits synchronized infrared pulsed. The object on the light path reflects the infrared radiation pulsed that are detected by the PS. With a narrow band optical coating on the proximity sensor, the PS only receives the infrared around 850nm wavelength, rejecting most ambient light interference. By using the track-and hold (T&H) and correlated double sample (CDS) techniques, the PS is capable of measuring the intensity of reflected infrared pulsed. Proper infrared baffle may be required due to the crosstalk from IRED to PS.

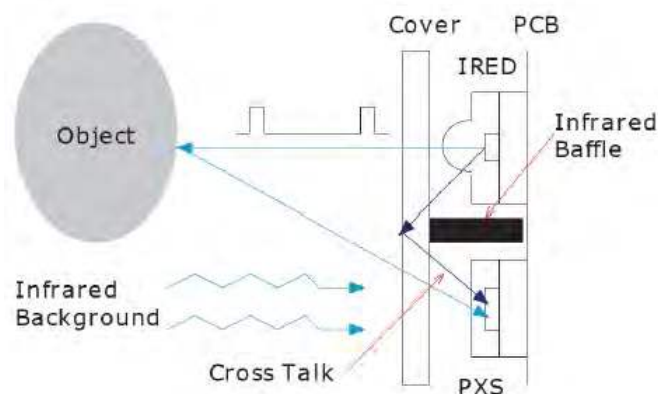

Figure 5. Proximity Sensing

When the EAAPMST3923A2's proximity sensing is enable (PS_EN=1), the PS takes about 0.54mS to take one measurement. The pulsed driving current of the IRED can be 100mA in amplitude by setting IRED_DR low (IRED_DR=0), or 200mA by setting IRED_DR high (IRED_DR=1). The sleep time (t_{sleep}) between proximity measurement is determined by setting the PS_SLP bits.

Interrupt Function

Four interrupt threshold registers allow the user to set limits below and above a desired light level and proximity range. An ALS interrupt can be generated when the ALS data (ALS_DT) falls outside of the desired light level range, as determined by the values in the ALS interrupt low threshold registers (ALS_LT) and ALS interrupt high threshold registers (ALS_HT). Likewise, an out-of-range proximity interrupt can be generated when the proximity data (PS_DT) falls below the proximity interrupt low threshold (PS_LT) or exceeds the proximity interrupt high threshold (PS_HT).

To further control when an interrupt occurs, the device provides a persistence filter. The persistence filter allows the user to specify the number of consecutive out-of-range ALS or proximity occurrences before an interrupt is generated. The interrupt register (Register 0x02) allows the user to set the ALS persistence (ALS_PRST) and the proximity persistence (PS_PRST) values. See the interrupt for details on the persistence filter values. Once the persistence filter generates an interrupt, it will continue until a write operation is performed on Register 0x02.

The final interrupt option is the ability to AND or OR the two interrupt flags using Register 0x02 Bit 0 (INT_CTRL). If the user wants both ALS/PS interrupts to happen at the same time before changing the state of the interrupt pin, set this bit high (AND operation). If the user wants the interrupt pin to change state when either the ALS or the proximity interrupt flag goes high, leave this bit to its default of 0 (OR operation).

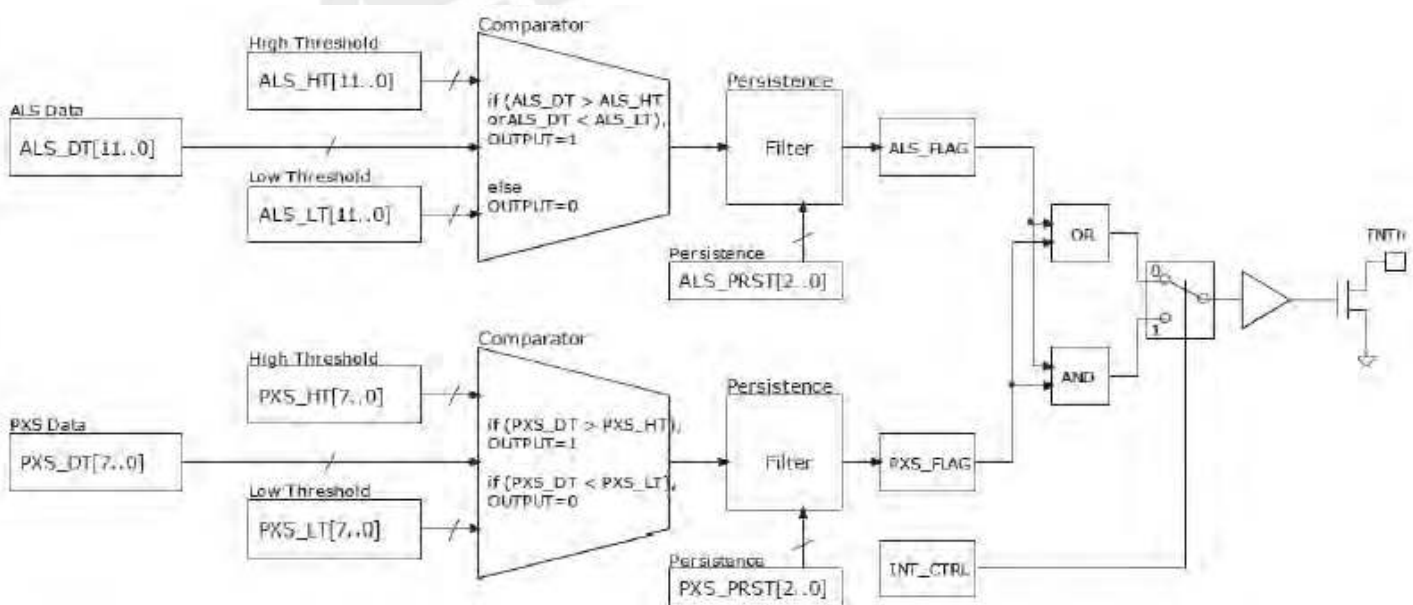

Figure 6. Interrupt operation

VDD Power-up and Power Supply

Upon power-up, please ensure the slew rate of VDD greater than 0.5V/mS. After power-up, the supply voltage shall NOT drop below 2.0V. Once it happens, please switch off the power, wait more than 1 second, and then power on the device again.

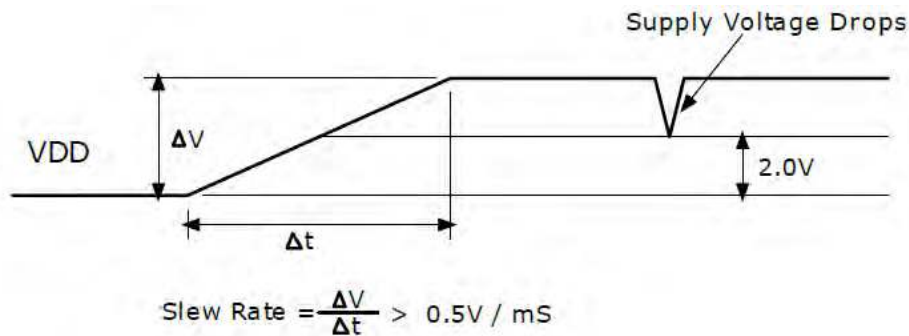

Figure 7. Waveform of Supply Voltage VDD

Power-Down

To put the EAAPMST3923A2 into a power-down state, the user can set both PS_EN bits and ALS to 0 in Register 0x01. Or more simply, set all of Register 0x01 to 0x00.

Calculating Lux

The EAAPMST3923A2's ADC output codes are directly proportional to lux when in ALS mode (see ALS_MODE bit.)

$$E_{calc} = \alpha \text{RANGE} \times \text{OUTADC}$$

E_{calc} is the calculated lux reading and OUT represents the ADC code. The constant α to plug in is determined by the range bits ALS_RANGE (bit 2: 0 of register 0x0B) and is independent of the light source type. Below Table shows five different scale factors: from 0.195 lux/count to 0.012 lux/count.

ALS_RANGE	αRANGE (lux/count)
0	0.195
1	0.098
2	0.048
3	0.024
4~7	0.012

Table 1. ALS sensitivity at different range

Label Format

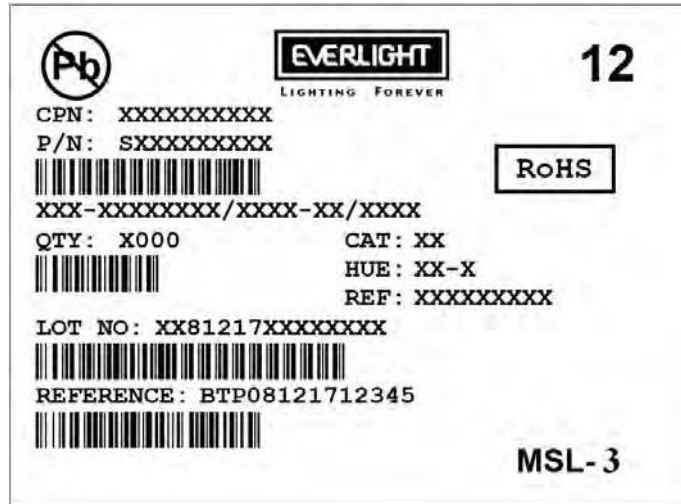

Reel Dimensions

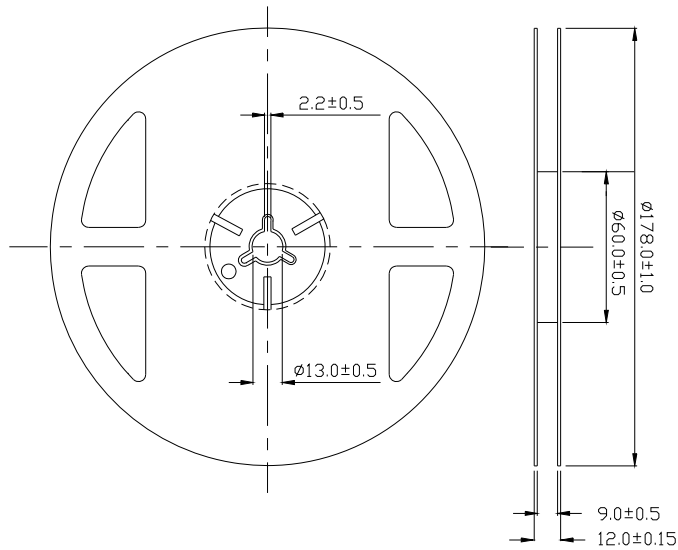

Unit: mm
Tolerances: ± 0.1 mm

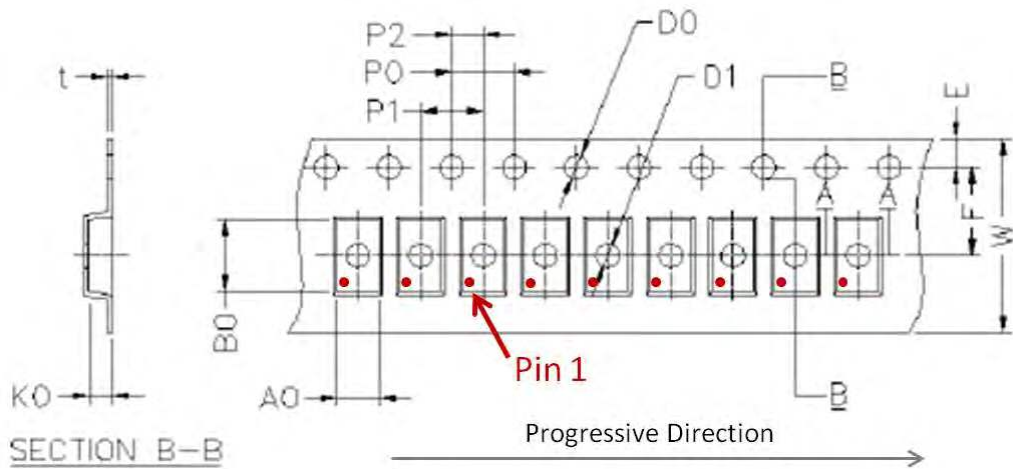

Symbol		Unit: mm
W	E	F
12.00+0.1 -0.3	1.75±0.10	5.50±0.1
D0	D1	P0
1.50+0.10 -0	1.50+0.10 -0	4.00±0.1
P1	P2	t
4.00±0.10	2.00±0.1	0.3±0.05
A0	B0	K0
2.7±0.1	4.5±0.1	1.9±0.1

Notes:

1.2000pcs/Reel.

Moisture Resistant Packing Process

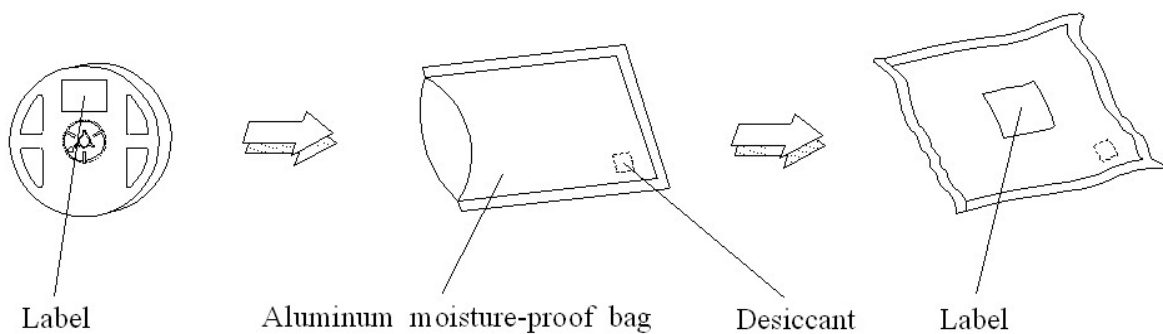

Recommended Method of Storage

1. Do not open moisture proof bag before devices are ready to use.
2. Shelf life in sealed bag from the bag seal date: 18 months at 10°C~ 30°C and < 90% RH.
3. After opening the package, the devices must be stored at 10°C~ 30°C and ≤ 60%RH, and used within 168 hours (floor life).
4. If the moisture absorbent material (desiccant material) has faded or unopened bag has exceeded the shelf life or devices (out of bag) have exceeded the floor life, baking treatment is required.
5. If baking is required, refer to IPC/JEDEC J-STD-033 for bake procedure or recommend the following conditions:
 - 192 hours at 40°C + 5/-0°C and < 5 % RH (reeled/tubed/loose units) or
 - 96 hours at 60°C ± 5°C and < 5 % RH (reeled/tubed/loose units) or
 - 24 hours at 125°C ± 5°C, not suitable for reel or tubes.

Recommended Solder Profile

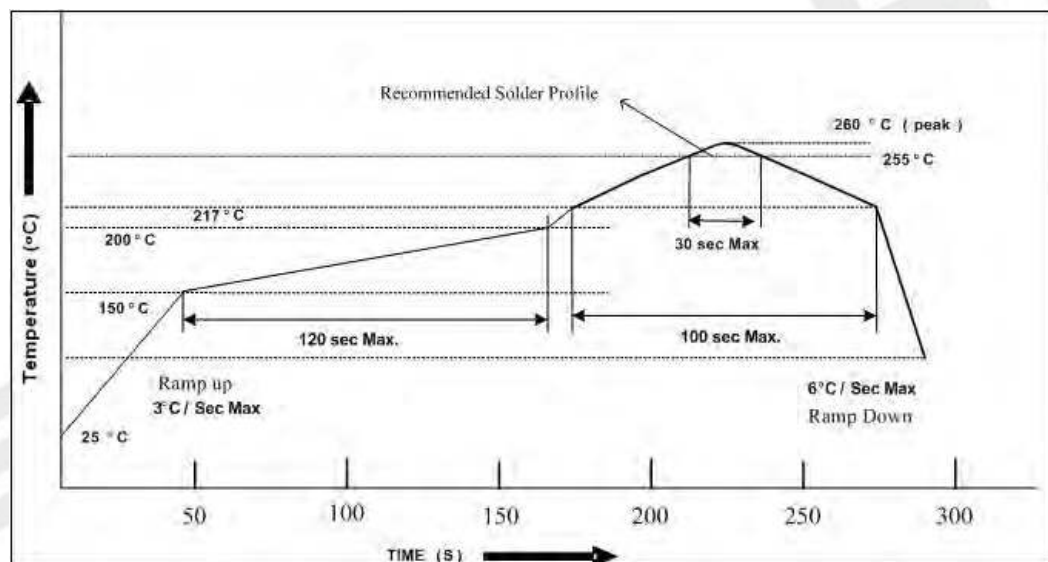

Notice:

1. Reflow soldering should not be done more than two times.
2. When soldering, do not put stress on the devices during heating.
3. After soldering, do not warp the circuit board.
4. Reference: IPC/JEDEC J-STD-020D

DISCLAIMER

1. EVERLIGHT reserves the right(s) on the adjustment of product material mix for the specification.
2. The product meets EVERLIGHT published specification for a period of twelve (12) months from date of shipment.
3. The graphs shown in this datasheet are representing typical data only and do not show guaranteed values.
4. When using this product, please observe the absolute maximum ratings and the instructions for using outlined in these specification sheets. EVERLIGHT assumes no responsibility for any damage resulting from the use of the product which does not comply with the absolute maximum ratings and the instructions included in these specification sheets.
5. These specification sheets include materials protected under copyright of EVERLIGHT. Reproduction in any form is prohibited without obtaining EVERLIGHT's prior consent.
6. This product is not intended to be used for military, aircraft, automotive, medical, life sustaining or life saving applications or any other application which can result in human injury or death. Please contact authorized Everlight sales agent for special application request.

EVERLIGHT