



Serially Controlled, Low-Voltage, 8-Channel SPST Switch

MAX395

General Description

The MAX395 8-channel, serially controlled, single-pole/single-throw (SPST) analog switch offers eight separately controlled switches. The switches conduct equally well in either direction. On-resistance (100Ω max) is matched between switches to 5Ω max and is flat (10Ω max) over the specified signal range.

These CMOS devices can operate continuously with dual power supplies ranging from ±2.7V to ±8V or a single supply between +2.7V and +16V. Each switch can handle rail-to-rail analog signals. The off leakage current is only 0.1nA at +25°C or 5nA at +85°C.

Upon power-up, all switches are off, and the internal shift registers are reset to zero. The MAX395 is electrically equivalent to two MAX391 quad switches controlled by a serial interface, and is pin compatible with the MAX335.

The serial interface is compatible with SPI™/QSPI™ and Microwire™. Functioning as a shift register, it allows data (at DIN) to be clocked in synchronously with the rising edge of clock (SCLK). The shift register's output (DOUT) enables several MAX395s to be daisy chained.

All digital inputs have 0.8V to 2.4V logic thresholds, ensuring both TTL- and CMOS-logic compatibility when using ±5V supplies or a single +5V supply.

Applications

- | | |
|---------------------------------|--|
| Serial Data-Acquisition Systems | Industrial and Process-Control Systems |
| Avionics | ATE Equipment |
| Audio Signal Routing | Networking |

Pin Configuration

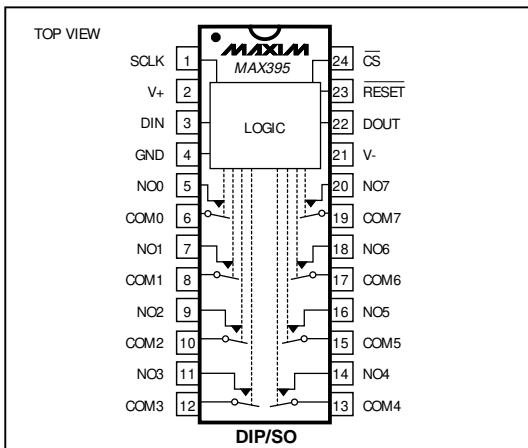

Features

- ♦ SPI™/QSPI™, Microwire™-Compatible Serial Interface
- ♦ 8 Separately Controlled SPST Switches
- ♦ 100Ω Signal Paths with ±5V Supplies
- ♦ Rail-to-Rail Signal Handling
- ♦ Asynchronous RESET Input
- ♦ Pin Compatible with Industry-Standard MAX335
- ♦ ±2.7V to ±8V Dual Supplies
+2.7V to +16V Single Supply
- ♦ >2kV ESD Protection per Method 3015.7
- ♦ TTL/CMOS-Compatible Inputs (with +5V or ±5V Supplies)

Ordering Information

PART	TEMP. RANGE	PIN-PACKAGE
MAX395CNG	0°C to +70°C	24 Narrow Plastic DIP
MAX395CWG	0°C to +70°C	24 Wide SO
MAX395C/D	0°C to +70°C	Dice*
MAX395ENG	-40°C to +85°C	24 Narrow Plastic DIP
MAX395EWG	-40°C to +85°C	24 Wide SO
MAX395MRG	-55°C to +125°C	24 Narrow CERDIP**

* Contact factory for dice specifications.
** Contact factory for availability.

Functional Diagram

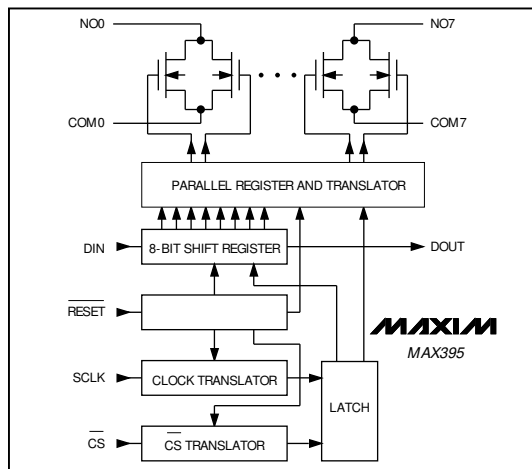

SPI and QSPI are trademarks of Motorola, Inc. Microwire is a trademark of National Semiconductor Corp.



Call toll free 1-800-998-8800 for free samples or literature.

Serially Controlled, Low-Voltage, 8-Channel SPST Switch

MAX395

ABSOLUTE MAXIMUM RATINGS

Voltages Referenced to GND

V+	-0.3V, +17V
V-	-17V, +0.3V
V+ to V-	-0.3V, +17V
SCLK, CS, DIN, DOUT, RESET	-0.3V to (V+ + 0.3V)
NO, COM	(V- - 2V) to (V+ + 2V)
Continuous Current into Any Terminal	±30mA
Peak Current, NO _i or COM _i (pulsed at 1ms, 10% duty cycle)	±100mA

Continuous Power Dissipation (T_A = +70°C)

Narrow Plastic DIP (derate 13.33mW/°C above +70°C)	1067mW
Wide SO (derate 11.76mW/°C above +70°C)	941mW
Narrow CERDIP (derate 12.50mW/°C above +70°C)	1000mW

Operating Temperature Ranges

MAX395C_G	0°C to +70°C
MAX395E_G	-40°C to +85°C
MAX395MRG	-55°C to +125°C
Storage Temperature Range	-65°C to +150°C
Lead Temperature (soldering, 10sec)	+300°C

Stresses beyond those listed under "Absolute Maximum Ratings" may cause permanent damage to the device. These are stress ratings only, and functional operation of the device at these or any other conditions beyond those indicated in the operational sections of the specifications is not implied. Exposure to absolute maximum rating conditions for extended periods may affect device reliability.

ELECTRICAL CHARACTERISTICS—Dual Supplies

(V+ = +4.5V to +5.5V, V- = -4.5V to -5.5V, T_A = T_{MIN} to T_{MAX}, unless otherwise noted. Typical values are at T_A = +25°C.)

PARAMETER	SYMBOL	CONDITIONS	MIN	TYP (Note 1)	MAX	UNITS
ANALOG SWITCH						
Analog Signal Range	V _{COM} , V _{NO}		C, E, M	V-	V+	V
COM, NO On-Resistance	R _{ON}	V+ = 5V, V- = -5V, V _{COM} = ±3V, I _{NO} = 1mA	T _A = +25°C	60	100	Ω
COM, NO On-Resistance Match Between Channels (Note 2)	ΔR _{ON}	V+ = 5V, V- = -5V, V _{COM} = ±3V, I _{NO} = 1mA	T _A = +25°C		5	Ω
COM, NO On-Resistance Flatness (Note 2)	R _{FLAT(ON)}	V+ = 5V, V- = -5V, I _{NO} = 1mA, V _{COM} = -3V, 0V, 3V	T _A = +25°C		10	Ω
NO Off Leakage Current (Note 3)	I _{NO(OFF)}	V+ = 5.5V, V- = -5.5V, V _{COM} = -4.5V, V _{NO} = 4.5V	T _A = +25°C	-0.1	0.002	0.1
		V+ = 5.5V, V- = -5.5V, V _{COM} = 4.5V, V _{NO} = -4.5V	T _A = +25°C	-0.1	0.002	0.1
COM Off Leakage Current (Note 3)	I _{COM(OFF)}	V+ = 5.5V, V- = -5.5V, V _{COM} = -4.5V, V _{NO} = 4.5V	T _A = +25°C	-0.1	0.002	0.1
		V+ = 5.5V, V- = -5.5V, V _{COM} = 4.5V, V _{NO} = -4.5V	T _A = +25°C	0.1	0.002	0.1
COM On Leakage Current (Note 3)	I _{COM(ON)}	V+ = 5.5V, V- = -5.5V, V _{COM} = V _{NO} = ±4.5V	T _A = +25°C	-0.2	0.01	0.2
DIGITAL I/O						
DIN, SCLK, CS, RESET Input Voltage Logic Threshold High	V _{IH}		C, E, M	2.4		V
DIN, SCLK, CS, RESET Input Voltage Logic Threshold Low	V _{IL}		C, E, M		0.8	V
DIN, SCLK, CS, RESET Input Current Logic High or Low	I _{IH} , I _{IL}	V _{DIN} , V _{SCLK} , V _{CS} = 0.8V or 2.4V	C, E, M	-1	0.03	1
DOUT Output Voltage Logic High	V _{DOUT}	I _{DOUT} = 0.8mA	C, E, M	2.8	V+	V
DOUT Output Voltage Logic Low	V _{DOUT}	I _{DOUT} = -1.6mA	C, E, M	0	0.4	V
SCLK Input Hysteresis	SCLK _{HYST}		C, E, M		100	mV

Serially Controlled, Low-Voltage, 8-Channel SPST Switch

MAX395

ELECTRICAL CHARACTERISTICS—Dual Supplies (continued)

(V+ = +4.5V to +5.5V, V- = -4.5V to -5.5V, T_A = T_{MIN} to T_{MAX}, unless otherwise noted. Typical values are at T_A = +25°C.)

PARAMETER	SYMBOL	CONDITIONS	MIN	TYP (Note 1)	MAX	UNITS
SWITCH DYNAMIC CHARACTERISTICS						
Turn-On Time	t _{ON}	From rising edge of \overline{CS}	T _A = +25°C	200	400	ns
			C, E, M		500	
Turn-Off Time	t _{OFF}	From rising edge of \overline{CS}	T _A = +25°C	90	400	ns
			C, E, M		500	
Break-Before-Make Delay	t _{BBM}	From rising edge of \overline{CS}	T _A = +25°C	5	15	ns
Charge Injection (Note 4)	V _{CTE}	C _L = 1nF, V _{NO} = 0V, R _S = 0Ω	T _A = +25°C	2	10	pC
NO Off Capacitance	C _{NO(OFF)}	V _{NO} = GND, f = 1MHz	T _A = +25°C	2		pF
COM Off Capacitance	C _{COM(OFF)}	V _{COM} = GND, f = 1MHz	T _A = +25°C	2		pF
Switch On Capacitance	C _(ON)	V _{COM} = V _{NO} = GND, f = 1MHz	T _A = +25°C	8		pF
Off Isolation	V _{ISO}	R _L = 50Ω, C _L = 15pF, V _{NO} = 1V _{RMS} , f = 100kHz	T _A = +25°C	-90		dB
Channel-to-Channel Crosstalk	V _{CT}	R _L = 50Ω, C _L = 15pF, V _{NO} = 1V _{RMS} , f = 100kHz	T _A = +25°C	<-90		dB
POWER SUPPLY						
Power-Supply Range	V+, V-		C, E, M	±3	±8	V
V+ Supply Current	I+	DIN = \overline{CS} = SCLK = 0V or V+, RESET = 0V or V+	T _A = +25°C	7	20	μA
			C, E, M		30	
V- Supply Current	I-	DIN = \overline{CS} = SCLK = 0V or V+, RESET = 0V or V+	T _A = +25°C	-1	1	μA
			C, E, M		-2	

Serially Controlled, Low-Voltage, 8-Channel SPST Switch

MAX395

TIMING CHARACTERISTICS—Dual Supplies (Figure 1)

(V₊ = +4.5V to +5.5V, V₋ = -4.5V to -5.5V, T_A = T_{MIN} to T_{MAX}, unless otherwise noted. Typical values are at T_A = +25°C.)

PARAMETER	SYMBOL	CONDITIONS	MIN	TYP (Note 1)	MAX	UNITS
SERIAL DIGITAL INTERFACE						
SCLK Frequency	f _{SCLK}		C, E, M	0	2.1	MHz
Cycle Time	t _{CH} + t _{CL}		C, E, M	480		ns
CS Lead Time	t _{CSS}		C, E, M	240		ns
CS Lag Time	t _{CSH2}		C, E, M	240		ns
SCLK High Time	t _{CH}		C, E, M	190		ns
SCLK Low Time	t _{CL}		C, E, M	190		ns
Data Setup Time	t _{DS}		C, E, M	200	17	ns
Data Hold Time	t _{DH}		C, E, M	0	-17	ns
DIN Data Valid after Falling SCLK (Note 4)	t _{DO}	50% of SCLK to 10% of DOUT, C _L = 10pF	T _A = +25°C C, E, M	85	400	ns
Rise Time of DOUT (Note 4)	t _{DR}	20% of V ₊ to 70% of V ₊ , C _L = 10pF	C, E, M		100	ns
Allowable Rise Time at DIN, SCLK (Note 4)	t _{SCR}	20% of V ₊ to 70% of V ₊ , C _L = 10pF	C, E, M		2	μs
Fall Time of DOUT (Note 4)	t _{DF}	20% of V ₊ to 70% of V ₊ , C _L = 10pF	C, E, M		100	ns
Allowable Fall Time at DIN, SCLK (Note 4)	t _{SCF}	20% of V ₊ to 70% of V ₊ , C _L = 10pF	C, E, M		2	μs
RESET Minimum Pulse Width	t _{RW}		T _A = +25°C	70		ns

Note 1: The algebraic convention is used in this data sheet; the most negative value is shown in the minimum column.

Note 2: ΔRON = RON(max) - RON(min). On-resistance match between channels and on-resistance flatness are guaranteed only with specified voltages. Flatness is defined as the difference between the maximum and minimum value of on-resistance as measured over the specified analog signal range.

Note 3: Leakage parameters are 100% tested at maximum rated hot temperature and guaranteed by correlation at room temp.

Note 4: Guaranteed by design.

Note 5: Leakage testing at single supply is guaranteed by testing with dual supplies.

Note 6: See Figure 6. Off isolation = 20log₁₀ V_{COM}/V_{NO}, V_{COM} = output. NO = input to off switch.

Note 7: Between any two switches. See Figure 3.

Serially Controlled, Low-Voltage, 8-Channel SPST Switch

MAX395

ELECTRICAL CHARACTERISTICS—Single +5V Supply

(V+ = +4.5V to +5.5V, V- = 0V, T_A = T_{MIN} to T_{MAX}, unless otherwise noted. Typical values are at T_A = +25°C.)

PARAMETER	SYMBOL	CONDITIONS	MIN	TYP (Note 2)	MAX	UNITS	
ANALOG SWITCH							
Analog Signal Range	V _{COM} , V _{NO}	C, E, M	V-		V+	V	
COM, NO On-Resistance	R _{ON}	V+ = 5V, V _{COM} = 3.5V, I _{NO} = 1mA	T _A = +25°C	125	175	Ω	
			C, E, M		225		
NO Off Leakage Current (Notes 4, 5)	I _{NO(OFF)}	V+ = 5.5V, V _{COM} = 4.5V, V _{NO} = 0V	T _A = +25°C	-0.1	0.002	0.1	nA
			C, E, M	-10		10	
		V+ = 5.5V, V _{COM} = 0V, V _{NO} = 4.5V	T _A = +25°C	-0.1	0.002	0.1	
			C, E, M	-10		10	
COM Off Leakage Current (Notes 4, 5)	I _{COM(OFF)}	V+ = 5.5V, V _{COM} = 4.5V, V _{NO} = 0V	T _A = +25°C	-0.1	0.002	0.1	nA
			C, E, M	-10		10	
		V+ = 5.5V, V _{COM} = 0V, V _{NO} = 4.5V	T _A = +25°C	-0.1	0.002	0.1	
			C, E, M	-10		10	
COM On Leakage Current (Notes 4, 5)	I _{COM(ON)}	V+ = 5.5V, V _{COM} = V _{NO} = 4.5V	T _A = +25°C	-0.2	0.002	0.2	nA
			C, E, M	-20		20	
DIGITAL I/O							
DIN, SCLK, $\overline{\text{CS}}$, RESET Input Voltage Logic Threshold High	V _{IH}		C, E, M	2.4		V	
DIN, SCLK, $\overline{\text{CS}}$, RESET Input Voltage Logic Threshold Low	V _{IL}		C, E, M		0.8	V	
DIN, SCLK, $\overline{\text{CS}}$, RESET Input Current Logic High or Low	I _{IH} , I _{IL}	V _{DIN} , V _{SCLK} , V $\overline{\text{CS}}$ = 0.8V or 2.4V	C, E, M	-1	0.03	1	μA
DOUT Output Voltage Logic High	V _{DOUT}	I _{DOUT} = -0.8mA	C, E, M	2.8		V+	V
DOUT Output Voltage Logic Low	V _{DOUT}	I _{DOUT} = 1.6mA	C, E, M	0		0.4	V
SCLK Input Hysteresis	SCLK _{HYST}		C, E, M		100		mV
SWITCH DYNAMIC CHARACTERISTICS							
Turn-On Time	t _{ON}	From rising edge of $\overline{\text{CS}}$	T _A = +25°C	200	400	ns	
			C, E, M		500		
Turn-Off Time	t _{OFF}	From rising edge of $\overline{\text{CS}}$	T _A = +25°C	90	400	ns	
			C, E, M		500		
Break-Before-Make Delay	t _{BBM}	From rising edge of $\overline{\text{CS}}$	T _A = +25°C	15		ns	
Charge Injection (Note 4)	V _{CTE}	C _L = 1nF, V _{NO} = 0V, R _S = 0Ω	T _A = +25°C	2	10	pC	
Off Isolation (Note 6)	V _{ISO}	R _L = 50Ω, C _L = 15pF, V _{NO} = 1V _{RMS} , f = 100kHz	T _A = +25°C	-90		dB	
Channel-to-Channel Crosstalk (Note 7)	V _{CT}	R _L = 50Ω, C _L = 15pF, V _{NO} = 1V _{RMS} , f = 100kHz	T _A = +25°C	<-90		dB	
POWER SUPPLY							
V+, V- Supply Current	I+	DIN = $\overline{\text{CS}}$ = SCLK = 0V or V+, RESET = 0V or V+	T _A = +25°C	7	20	μA	
			C, E, M		30		

Serially Controlled, Low-Voltage, 8-Channel SPST Switch

TIMING CHARACTERISTICS—Single +5V Supply (Figure 1)

(V₊ = +4.5V to +5.5V, V₋ = 0V, T_A = T_{MIN} to T_{MAX}, unless otherwise noted. Typical values are at T_A = +25°C.)

PARAMETER	SYMBOL	CONDITIONS	MIN	TYP (Note 2)	MAX	UNITS
SERIAL DIGITAL INTERFACE						
SCLK Frequency	f _{SCLK}		C, E, M	0	2.1	MHz
Cycle Time (Note 4)	t _{CH} + t _{CL}		C, E, M	480		ns
$\overline{\text{CS}}$ Lead Time (Note 4)	t _{CS}		C, E, M	240		ns
$\overline{\text{CS}}$ Lag Time (Note 4)	t _{CSH2}		C, E, M	240		ns
SCLK High Time (Note 4)	t _{CH}		C, E, M	190		ns
SCLK Low Time (Note 4)	t _{CL}		C, E, M	190		ns
Data Setup Time (Note 4)	t _{DS}		C, E, M	200	17	ns
Data Hold Time (Note 4)	t _{DH}		C, E, M	0	-17	ns
DIN Data Valid after Falling SCLK (Note 4)	t _{DO}	50% of SCLK to 10% of DOUT, C _L = 10pF	T _A = +25°C	85		ns
			C, E, M		400	
Rise Time of DOUT (Note 4)	t _{DR}	20% of V ₊ to 70% of V ₊ , C _L = 10pF	C, E, M		100	ns
Allowable Rise Time at DIN, SCLK (Note 4)	t _{SCR}	20% of V ₊ to 70% of V ₊ , C _L = 10pF	C, E, M		2	μs
Fall Time of DOUT (Note 4)	t _{DF}	20% of V ₊ to 70% of V ₊ , C _L = 10pF	C, E, M		100	ns
Allowable Fall Time at DIN, SCLK (Note 4)	t _{SCF}	20% of V ₊ to 70% of V ₊ , C _L = 10pF	C, E, M		2	μs
RESET Minimum Pulse Width	t _{RW}		T _A = +25°C	70		ns

Note 1: The algebraic convention is used in this data sheet; the most negative value is shown in the minimum column.

Note 2: $\Delta R_{ON} = R_{ON(max)} - R_{ON(min)}$. On-resistance match between channels and on-resistance flatness are guaranteed only with specified voltages. Flatness is defined as the difference between the maximum and minimum value of on-resistance as measured over the specified analog signal range.

Note 3: Leakage parameters are 100% tested at maximum rated hot temperature and guaranteed by correlation at room temp.

Note 4: Guaranteed by design.

Note 5: Leakage testing at single supply is guaranteed by testing with dual supplies.

Note 6: See Figure 6. Off isolation = $20 \log_{10} V_{COM}/V_{NO}$. V_{COM} = output. NO = input to off switch.

Note 7: Between any two switches. See Figure 3.

Serially Controlled, Low-Voltage, 8-Channel SPST Switch

MAX395

ELECTRICAL CHARACTERISTICS—Single +3V Supply

(V+ = +3.0V to +3.6V, V- = 0V, T_A = T_{MIN} to T_{MAX}, unless otherwise noted. Typical values are at T_A = +25°C.)

PARAMETER	SYMBOL	CONDITIONS	MIN	TYP (Note 2)	MAX	UNITS		
ANALOG SWITCH								
Analog Signal Range	V _{COM} , V _{NO}	C, E, M	V-		V+	V		
COM, NO On-Resistance	R _{ON}	V+ = 3.0V, V _{COM} = 1.5V, I _{NO} = 1mA	T _A = +25°C		270	500	Ω	
			C, E, M			600		
NO Off Leakage Current (Notes 4, 5)	I _{NO(OFF)}	V+ = 3.0V, V _{COM} = 3V, V _{NO} = 0V	T _A = +25°C		-0.1	0.002	0.1	nA
			C, E, M		-5		5	
		V+ = 3.6V, V _{COM} = 0V, V _{NO} = 3V	T _A = +25°C		-0.1	0.002	0.1	
			C, E, M		-5		5	
COM Off Leakage Current (Notes 4, 5)	I _{COM(OFF)}	V+ = 3.6V, V _{COM} = 3V, V _{NO} = 0V	T _A = +25°C		-0.1	0.002	0.1	nA
			C, E, M		-5		5	
		V+ = 3.6V, V _{COM} = 0V, V _{NO} = 3V	T _A = +25°C		0.1	0.002	0.1	
			C, E, M		-5		5	
COM On Leakage Current (Notes 4, 5)	I _{COM(ON)}	V+ = 3.6V, V _{COM} = 3V, V _{NO} = 0V	T _A = +25°C		-0.1	0.002	0.1	nA
			C, E, M		-10		10	
		V+ = 3.6V, V _{COM} = 0V, V _{NO} = 3V	T _A = +25°C		-0.1	0.002	0.1	
			C, E, M		-10		10	
DIGITAL I/O								
DIN, SCLK, $\overline{\text{CS}}$, $\overline{\text{RESET}}$ Input Voltage Logic Threshold High	V _{IH}		C, E		2.4		V	
DIN, SCLK, $\overline{\text{CS}}$, $\overline{\text{RESET}}$ Input Voltage Logic Threshold Low	V _{IL}		C, E			0.8	V	
DIN, SCLK, $\overline{\text{CS}}$, Input Current Logic High or Low	I _{IH} , I _{IL}	V _{DIN} , V _{SCLK} , V _{$\overline{\text{CS}}$} = 0.8V or 2.4V	C, E		-1	0.03	1	μA
DOOUT Output Voltage Logic High	V _{DOUT}	I _{DOUT} = 0.1mA	C, E, M		2.8		V+	V
DOOUT Output Voltage Logic Low	V _{DOUT}	I _{DOUT} = -1.6mA	C, E, M		0		0.4	V
SCLK Input Hysteresis	SCLKHYST		C, E, M			100		mV
SWITCH DYNAMIC CHARACTERISTICS								
Turn-On Time	t _{ON}	From rising edge of $\overline{\text{CS}}$	T _A = +25°C		260	600	ns	
			C, E, M			800		
Turn-Off Time	t _{OFF}	From rising edge of $\overline{\text{CS}}$	T _A = +25°C		90	300	ns	
			C, E, M			400		
Break-Before-Make Delay	t _{BBM}	From rising edge of $\overline{\text{CS}}$	T _A = +25°C		15		ns	
Charge Injection (Note 4)	V _{CTE}	C _L = 1nF, V _{NO} = 0V, R _S = 0Ω	T _A = +25°C		2	10	pC	
Off Isolation (Note 6)	V _{ISO}	R _L = 50Ω, C _L = 15pF, V _{NO} = 1V _{RMS} , f = 100kHz	T _A = +25°C		-90		dB	
Channel-to-Channel Crosstalk (Note 7)	V _{CT}	R _L = 50Ω, C _L = 15pF, V _{NO} = 1V _{RMS} , f = 100kHz	T _A = +25°C		<-90		dB	
POWER SUPPLY								
V+ Supply Current	I+	DIN = $\overline{\text{CS}}$ = SCLK = 0V or V+, RESET = 0V or 5V	T _A = +25°C		6	20	μA	
			C, E, M			30		

Serially Controlled, Low-Voltage, 8-Channel SPST Switch

TIMING CHARACTERISTICS—Single +3V Supply (Figure 1)

(V₊ = +3.0V to +3.6V, V₋ = 0V, T_A = T_{MIN} to T_{MAX}, unless otherwise noted. Typical values are at T_A = +25°C.)

PARAMETER	SYMBOL	CONDITIONS	MIN	TYP (Note 2)	MAX	UNITS
SERIAL DIGITAL INTERFACE						
SCLK Frequency	f _{SCLK}		C, E, M	0	2.1	MHz
Cycle Time (Note 4)	t _{CH} + t _{CL}		C, E, M	480		ns
\overline{CS} Lead Time (Note 4)	t _{CSS}		C, E, M	240		ns
\overline{CS} Lag Time (Note 4)	t _{CSH2}		C, E, M	240		ns
SCLK High Time (Note 4)	t _{CH}		C, E, M	190		ns
SCLK Low Time (Note 4)	t _{CL}		C, E, M	190		ns
Data Setup Time (Note 4)	t _{DS}		C, E, M	200	38	ns
Data Hold Time (Note 4)	t _{DH}		C, E, M	0	-38	ns
DIN Data Valid after Falling SCLK (Note 4)	t _{DO}	50% of SCLK to 10% of DOUT, C _L = 10pF	T _A = +25°C	150		ns
			C, E, M		400	
Rise Time of DOUT (Note 4)	t _{DR}	20% of V ₊ to 70% of V ₊ , C _L = 10pF	C, E, M		300	ns
Allowable Rise Time at DIN, SCLK (Note 4)	t _{SCR}	20% of V ₊ to 70% of V ₊ , C _L = 10pF	C, E, M		2	μs
Fall Time of DOUT (Note 4)	t _{DF}	20% of V ₊ to 70% of V ₊ , C _L = 10pF	C, E, M		300	ns
Allowable Fall Time at DIN, SCLK (Note 4)	t _{SCF}	20% of V ₊ to 70% of V ₊ , C _L = 10pF	C, E, M		2	μs
RESET Minimum Pulse Width	t _{RW}		T _A = +25°C	105		ns

Note 1: The algebraic convention is used in this data sheet; the most negative value is shown in the minimum column.

Note 2: $\Delta R_{ON} = R_{ON(max)} - R_{ON(min)}$. On-resistance match between channels and on-resistance flatness are guaranteed only with specified voltages. Flatness is defined as the difference between the maximum and minimum value of on-resistance as measured over the specified analog signal range.

Note 3: Leakage parameters are 100% tested at maximum rated hot temperature and guaranteed by correlation at room temp.

Note 4: Guaranteed by design.

Note 5: Leakage testing at single supply is guaranteed by testing with dual supplies.

Note 6: See Figure 6. Off isolation = $20 \log_{10} V_{COM}/V_{NO}$, V_{COM} = output. NO = input to off switch.

Note 7: Between any two switches. See Figure 3.

Serially Controlled, Low-Voltage, 8-Channel SPST Switch

MAX395

Typical Operating Characteristics

($V_+ = +5V$, $V_- = -5V$, $GND = 0V$, $T_A = +25^\circ C$, unless otherwise noted.)

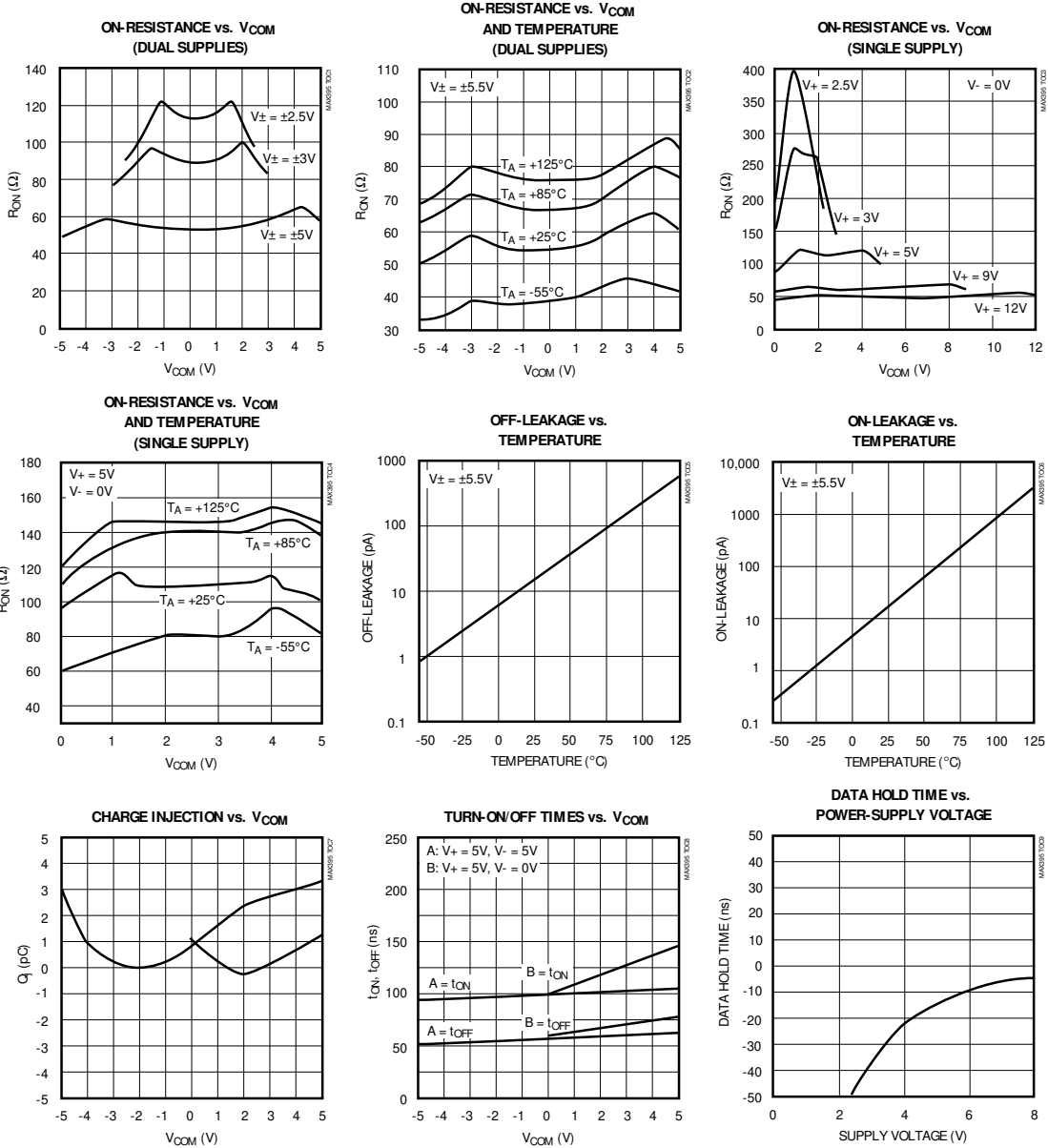

Serially Controlled, Low-Voltage, 8-Channel SPST Switch

Typical Operating Characteristics (continued)

(V+ = +5V, V- = -5V, GND = 0V, TA = +25°C, unless otherwise noted.)

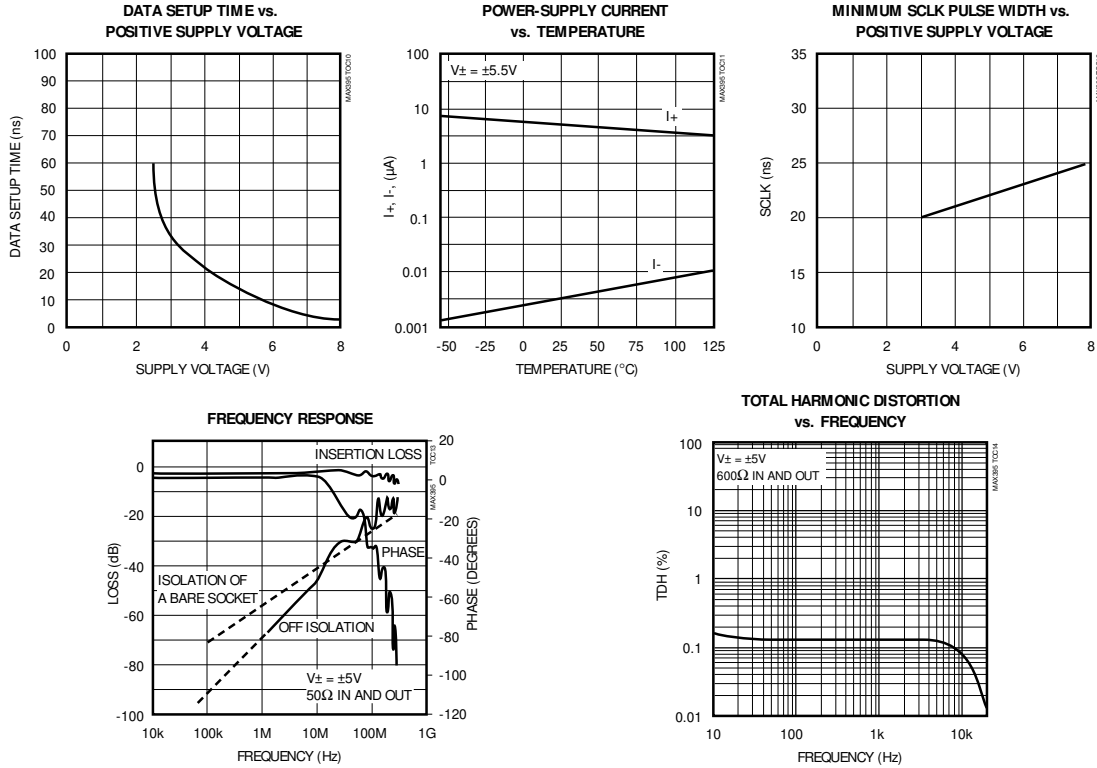

Pin Description

PIN	NAME	FUNCTION
1	SCLK	Serial Clock Digital Input
2	V+	Positive Analog Supply Voltage Input
3	DIN	Serial Data Digital Input
4	GND	Ground. Connect to digital ground. (Analog signals have no ground reference; they are limited to V+ and V-.)
5, 7, 9, 11, 14, 16, 18, 20	NO0–NO7	Normally Open Analog Switches 0–7
6, 8, 10, 12, 13, 15, 17, 19	COM0–COM7	Common Analog Switches 0–7
21	V-	Negative Analog Supply Voltage Input. Connect to GND for single-supply operation
22	DOUT	Serial Data Digital Output. (High is sourced from V+.)
23	RESET	Reset Input. Connect to digital (logic) supply (or V+). Drive low to set all switches off and set internal shift registers to 0.
24	CS	Chip-Select Digital Input (Figure 1)

Note: NO_ and COM_ pins are identical and interchangeable. Either may be considered as an input or an output; signals pass equally well in either direction.

Serially Controlled, Low-Voltage, 8-Channel SPST Switch

MAX395

Detailed Description

Basic Operation

The MAX395's interface can be thought of as an 8-bit shift register controlled by \overline{CS} (Figure 2). While \overline{CS} is low, input data appearing at DIN is clocked into the shift register synchronously with SCLK's rising edge. The data is an 8-bit word, each bit controlling one of eight switches in the MAX395 (Table 1). DOUT is the shift register's output, with data appearing synchronously with SCLK's falling edge. Data at DOUT is simply the input data delayed by eight clock cycles.

When shifting the input data, D7 is the first bit in and out of the shift register. While shifting data, the switches remain in their previous configuration. When the eight bits of data have been shifted in, \overline{CS} is driven high. This updates the new switch configuration and inhibits further data from entering the shift register. Transitions at DIN and SCLK have no effect when \overline{CS} is high, and DOUT holds the first input bit (D7) at its output.

More or less than eight clock cycles can be entered during the \overline{CS} low period. When this happens, the shift

register will contain only the last eight serial data bits, regardless of when they were entered. On the rising edge of \overline{CS} , all the switches will be set to the corresponding states.

The MAX395's three-wire serial interface is compatible with SPI™, QSPI™, and Microwire™ standards. If interfacing with a Motorola processor serial interface, set CPOL = 0. The MAX395 is considered a slave device (Figures 2 and 3). Upon power-up, the shift register contains all zeros, and all switches are off.

The latch that drives the analog switch is updated on the rising edge of \overline{CS} , regardless of SCLK's state. This meets all the SPI and QSPI requirements.

Daisy Chaining

For a simple interface using several MAX395s, "daisy chain" the shift registers as shown in Figure 5. The \overline{CS} pins of all devices are connected together, and a stream of data is shifted through the MAX395s in series. When \overline{CS} is brought high, all switches are updated simultaneously. Additional shift registers may be included anywhere in series with the MAX395 data chain.

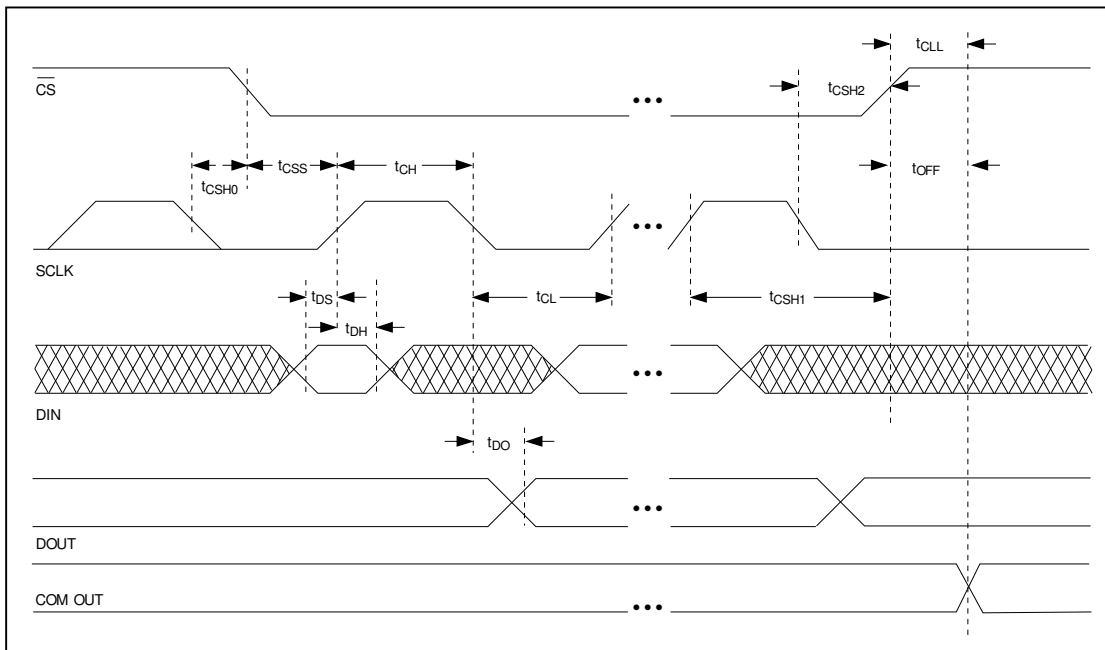

Figure 1. Timing Diagram

Serially Controlled, Low-Voltage, 8-Channel SPST Switch

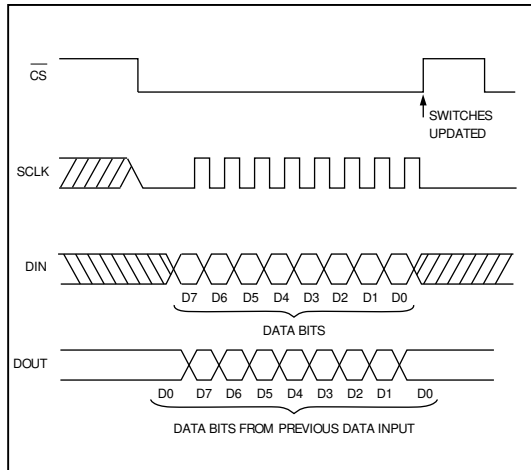

Figure 2. Three-Wire Interface Timing

Addressable Serial Interface

When several serial devices are configured as slaves, addressable by the processor, DIN pins of each decode logic individually control \overline{CS} of each slave device. When a slave is selected, its \overline{CS} pin is driven low, data is shifted in, and \overline{CS} is driven high to latch the data. Typically, only one slave is addressed at a time. DOUT is not used.

Applications Information

Multiplexers

The MAX395 can be used as a multiplexer, but to obtain the same electrical performance with slightly improved programming speed, use the MAX349 8-channel mux or the MAX350 dual 4-channel mux, both in 18-pin packages.

Table 1. Serial-Interface Switch Programming

RESET	DATA BITS								FUNCTION
	D7	D6	D5	D4	D3	D2	D1	D0	
0	X	X	X	X	X	X	X	X	All switches open, D7–D0 = 0
1	0	X	X	X	X	X	X	X	Switch 7 open (off)
1	1	X	X	X	X	X	X	X	Switch 7 closed (on)
1	X	0	X	X	X	X	X	X	Switch 6 open (off)
1	X	1	X	X	X	X	X	X	Switch 6 closed (on)
1	X	X	0	X	X	X	X	X	Switch 5 open (off)
1	X	X	1	X	X	X	X	X	Switch 5 closed (on)
1	X	X	X	0	X	X	X	X	Switch 4 open (off)
1	X	X	X	1	X	X	X	X	Switch 4 closed (on)
1	X	X	X	X	0	X	X	X	Switch 3 open (off)
1	X	X	X	X	1	X	X	X	Switch 3 closed (on)
1	X	X	X	X	X	0	X	X	Switch 2 open (off)
1	X	X	X	X	X	1	X	X	Switch 2 closed (on)
1	X	X	X	X	X	X	0	X	Switch 1 open (off)
1	X	X	X	X	X	X	1	X	Switch 1 closed (on)
1	X	X	X	X	X	X	X	0	Switch 0 open (off)
1	X	X	X	X	X	X	X	1	Switch 0 closed (on)

Serially Controlled, Low-Voltage, 8-Channel SPST Switch

MAX395

8x1 Multiplexer

To use the MAX395 as an 8x1 multiplexer, connect all common pins together (COM0–COM7) to form the mux output; the mux inputs are NO0–NO7.

The mux can be programmed normally, with only one channel selected for every eight clock pulses, or it can be programmed in a fast mode, where channel changing occurs on each clock pulse. In this mode, the channels are selected by sending a single high pulse (corresponding to the selected channel) at DIN, and a corresponding \overline{CS} low pulse for every eight clock pulses. As this is clocked through the register by SCLK, each switch sequences one channel at a time, starting with Channel 7.

Dual, Differential 4-Channel Multiplexer

To use the MAX395 as a dual (4x2) mux, connect COM0–COM3 together and connect COM4–COM7 together, forming the two outputs. The mux input pairs become NO0/NO4, NO1/NO5, NO2/NO6, and NO3/NO7.

The mux can be programmed normally, with only one differential channel selected for every eight clock pulses, or it can be programmed in a fast mode, where channel changing occurs on each clock pulse.

In fast mode, the channels are selected by sending two high pulses spaced four clock pulses apart (corresponding to the two selected channels) at DIN, and a corresponding \overline{CS} low pulse for each of the first eight clock pulses. As this is clocked through the register by

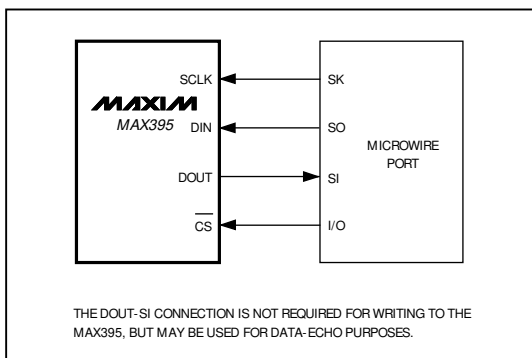

Figure 3. Connections for Microwire

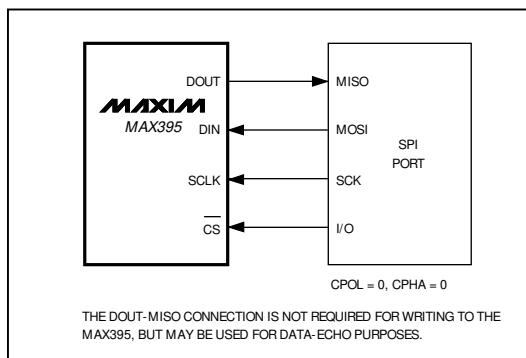

Figure 4. Connections for SPI and QSPI

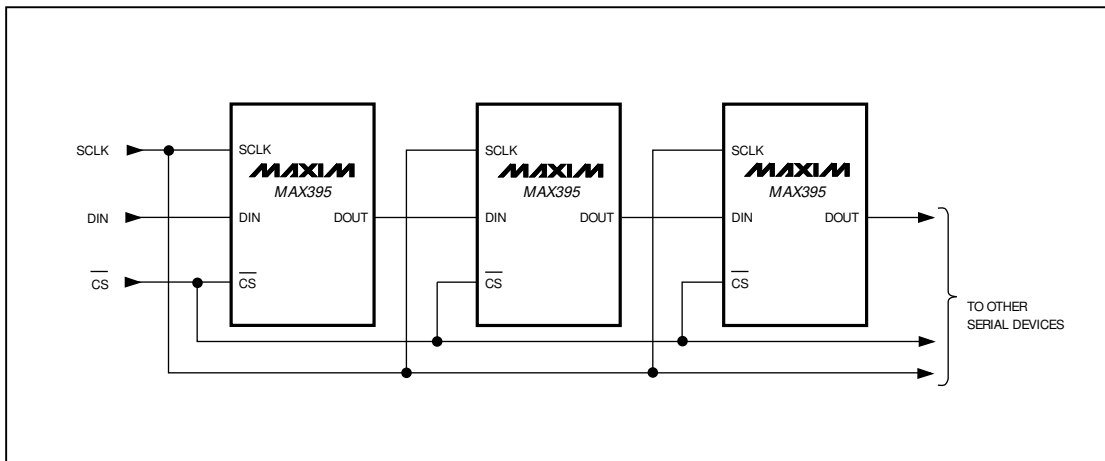

Figure 5. Daisy-Chained Connection

Serially Controlled, Low-Voltage, 8-Channel SPST Switch

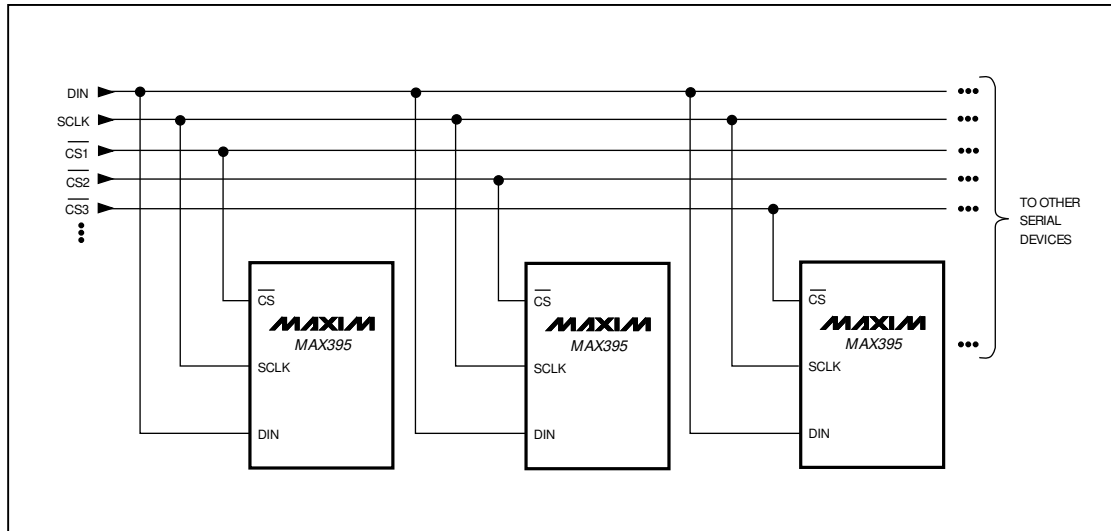

Figure 6. Addressable Serial Interface

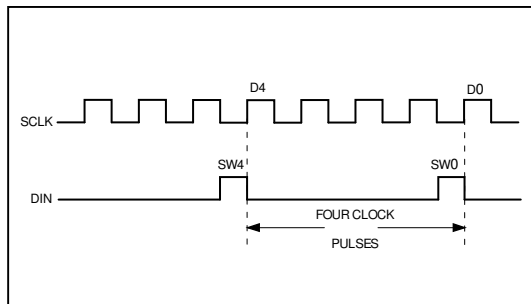

Figure 7. Differential Multiplexer Input Control

SCLK, each switch sequences one differential channel at a time, starting with channel 7/0. After the first eight bits have been sent, subsequent channel sequencing can occur by repeating this sequence or, even faster, by sending only one DIN high pulse and one CS low pulse for each four clock pulses.

SPDT Switches

To use the MAX395 as a quad, single-pole/double-throw (SPDT) switch, connect COM0 to NO1, COM2 to NO3, COM4 to NO5, and COM6 to NO7, forming the four "common" pins. Program these four switches with pairs of instructions, as shown in Table 2.

Reset Function

$\overline{\text{RESET}}$ is the internal reset pin. It is usually connected to a logic signal or V_+ . Drive $\overline{\text{RESET}}$ low to open all switches and set the contents of the internal shift register to zero simultaneously. When $\overline{\text{RESET}}$ is high, the part functions normally and DOUT is sourced from V_+ . $\overline{\text{RESET}}$ must not be driven beyond V_+ or GND.

Power-Supply Considerations

Overview

The MAX395 construction is typical of most CMOS analog switches. It has three supply pins: V_+ , V_- , and GND. V_+ and V_- are used to drive the internal CMOS switches and to set the limits of the analog voltage on any switch. Reverse ESD-protection diodes are internally connected between each analog signal pin and both V_+ and V_- . If any analog signal exceeds V_+ or V_- , one of these diodes will conduct. During normal operation, these (and other) reverse-biased ESD diodes leak, forming the only current drawn from V_+ or V_- .

Virtually all the analog leakage current is through the ESD diodes. Although the ESD diodes on a given signal pin are identical, and therefore fairly well balanced, they are reverse biased differently. Each is biased by either V_+ or V_- and the analog signal. This means their leakages vary as the signal varies. The difference in the two diode leakages to the V_+ and V_- pins constitutes the analog signal-path leakage current. All analog leak-

Serially Controlled, Low-Voltage, 8-Channel SPST Switch

MAX395

Table 2. SPDT Switch Programming

RESET	DATA BITS								FUNCTION
	D7	D6	D5	D4	D3	D2	D1	D0	
0	X	X	X	X	X	X	X	X	All switches open, D7–D0 = 0
1	0	1	X	X	X	X	X	X	Switch 7 off and 6 on
1	1	0	X	X	X	X	X	X	Switch 6 off and 7 on
1	X	X	0	1	X	X	X	X	Switch 5 off and 4 on
1	X	X	1	0	X	X	X	X	Switch 4 off and 5 on
1	X	X	X	X	0	1	X	X	Switch 3 off and 2 on
1	X	X	X	X	1	0	X	X	Switch 2 off and 3 on
1	X	X	X	X	X	X	0	1	Switch 1 off and 0 on
1	X	X	X	X	X	X	1	0	Switch 0 off and 1 on

age current flows to the supply terminals, not to the other switch terminal. This is why both sides of a given switch can show leakage currents of either the same or opposite polarity.

There is no connection between the analog signal paths and GND.

V+ and GND power the internal logic and logic-level translators, and set both the input and output logic limits. The logic-level translators convert the logic levels to switched V+ and V- signals to drive the analog signal gates. This drive signal is the only connection between the logic supplies (and signals) and the analog supplies. V+, and V- have ESD-protection diodes to GND. The logic-level inputs and output have ESD protection to V+ and to GND.

The logic-level thresholds are CMOS and TTL compatible when V+ is +5V. As V+ is raised, the threshold increases slightly. So when V+ reaches +12V, the threshold is about 3.1V; slightly above the TTL guaranteed high-level minimum of 2.8V, but still compatible with CMOS outputs.

Bipolar Supplies

The MAX395 operates with bipolar supplies between ±3.0V and ±8V. The V+ and V- supplies need not be symmetrical, but their sum cannot exceed the absolute maximum rating of 17V. **Do not connect the MAX395 V+ to +3V and connect the logic-level pins to TTL logic-level signals. This exceeds the absolute maximum ratings and can damage the part and/or external circuits.**

Single Supply

The MAX395 operates from a single supply between +3V and +16V when V- is connected to GND. All of the bipolar precautions must be observed.

High-Frequency Performance

In 50Ω systems, signal response is reasonably flat up to 50MHz (see *Typical Operating Characteristics*). Above 20MHz, the on-response has several minor peaks that are highly layout dependent. The problem is not turning the switch on, but turning it off. The off-state switch acts like a capacitor and passes higher frequencies with less attenuation. At 10MHz, off isolation is about -45dB in 50Ω systems, becoming worse (approximately 20dB per decade) as frequency increases. Higher circuit impedances also make off isolation worse. Adjacent channel attenuation is about 3dB above that of a bare IC socket, and is due entirely to capacitive coupling.

Serially Controlled, Low-Voltage, 8-Channel SPST Switch

MAX395

Chip Topography

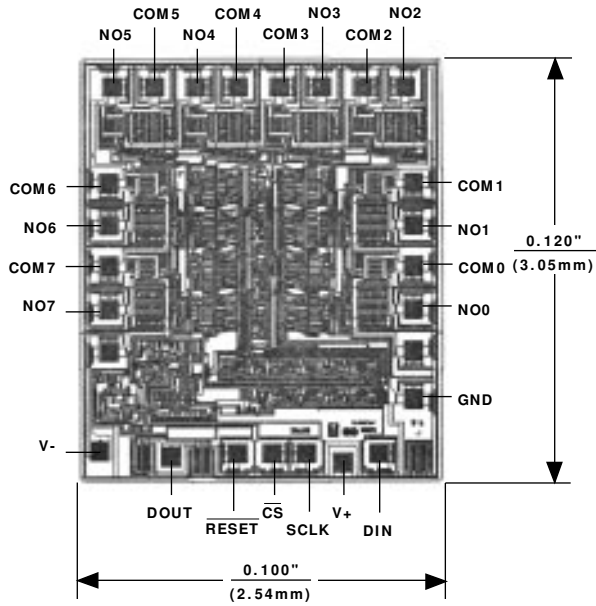

TRANSISTOR COUNT: 500
SUBSTRATE CONNECTED TO V+.

Maxim cannot assume responsibility for use of any circuitry other than circuitry entirely embodied in a Maxim product. No circuit patent licenses are implied. Maxim reserves the right to change the circuitry and specifications without notice at any time.

16 **Maxim Integrated Products, 120 San Gabriel Drive, Sunnyvale, CA 94086 (408) 737-7600**

© 1995 Maxim Integrated Products

Printed USA

MAXIM is a registered trademark of Maxim Integrated Products.