

MODEL CUB7 - MINIATURE ELECTRONIC 8 DIGIT COUNTER

- LCD, POSITIVE IMAGE REFLECTIVE OR NEGATIVE IMAGE TRANSMISSIVE WITH YELLOW/GREEN OR RED LED BACKLIGHTING (9-28 VDC power supply required for versions with LED backlighting)
- 0.35" (8.90 mm) HIGH DIGITS
- REPLACEABLE INTERNAL LITHIUM BATTERY PROVIDES UP TO 7 YEARS OF UNINTERRUPTED OPERATION
- NEMA 4X/IP65 SEALED FRONT BEZEL
- FRONT PANEL RESET OR REMOTE RESET
- COUNT SPEEDS UP TO 10 KHz
- WIRE CONNECTION MADE VIA SCREW CLAMP TYPE TERMINALS
- FITS DIN STANDARD CUT-OUT 1.77" (45 mm) x 0.874" (22.2 mm)

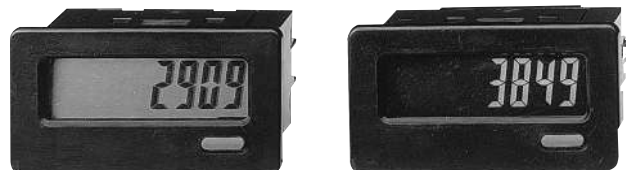

DESCRIPTION

The CUB7 is an 8-digit miniature counter with large 0.35 inch (8.90 mm) high digits. It has an LCD read-out available in Positive Image Reflective (CUB7000), Negative Image Transmissive with yellow/green backlighting (CUB70010) or red backlighting (CUB70020). The backlight versions require an external 9 to 28 VDC power supply.

The CUB7 counters use a CMOS LSI counter circuit chip, mounted on a gold-plated substrate, that is electrically connected by ultrasonic wire-bonding. Proven micro-electronic assembly and manufacturing techniques provide these units with the reliability and dependability required for industrial service.

The CUB7 series is housed in a lightweight, high impact plastic case with a clear viewing window. The sealed front panel with the silicone rubber reset button meets NEMA 4X/IP65 specifications for wash-down and/or dusty environments, when properly installed.

SAFETY SUMMARY

All safety related regulations, local codes and instructions that appear in the manual or on equipment must be observed to ensure personal safety and to prevent damage to either the instrument or equipment connected to it. If equipment is used in a manner not specified by the manufacturer, the protection provided by the equipment may be impaired.

Do not use this unit to directly command motors, valves, or other actuators not equipped with safeguards. To do so, can be potentially harmful to persons or equipment in the event of a fault to the unit.

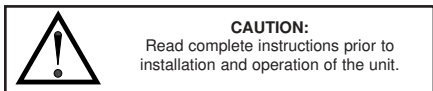

SPECIFICATIONS

- DISPLAY:** 8-digit LCD, 0.35" (8.90 mm) high digits.
- POWER SOURCE:** Replaceable Internal 3.0 V lithium battery to provide up to 7 years of continuous operation. (Battery life is dependent upon usage. Count and reset contacts that remain closed for long periods of time reduce battery life.)
- BACKLIGHT POWER REQUIREMENTS:** 9 to 28 VDC; 35 mA. typical, 50 mA max. Above 26 VDC, derate max. operating temperature to 40°C. Must use the MLPS or a Class 2 or SELV rated power supply.
- INPUTS (All);** $V_{IH} = 2.0$ V min. (3 V max), $V_{IL} = 0.5$ V max.
- HIGH SPEED INPUT:** 10 KHz max. from 3.0 V bipolar output with a 50% duty cycle.
- LOW SPEED INPUT:** 30 Hz max. from switch contact or open collector transistor with a 50% duty cycle.
- REMOTE RESET:** 15 msec min. pulse width (active low) from 3.0 V bipolar output, an open collector transistor, or a switch contact to common.
- ENVIRONMENTAL CONDITIONS:**
Operating Temperature Range: 0 to 50°C Derate max. operating temperature to 40°C above 26 VDC. (Backlight versions)
Storage Temperature Range: -30 to 80°C
Operating and Storage Humidity: 85% max. (non-condensing) from 0°C to 50°C.

Altitude: Up to 2000 meters

9. CERTIFICATIONS AND COMPLIANCES:

SAFETY

IEC 1010-1, EN 61010-1: Safety requirements for electrical equipment for measurement, control, and laboratory use, Part 1.

IP65 Enclosure rating (Face only), IEC 529

Type 4X Enclosure rating (Face only), UL50

DIMENSIONS In inches (mm)

Note: Recommended minimum clearance (behind the panel) for mounting clip installation is 2.15" (54.6) H x 3.00" (76.2) W.

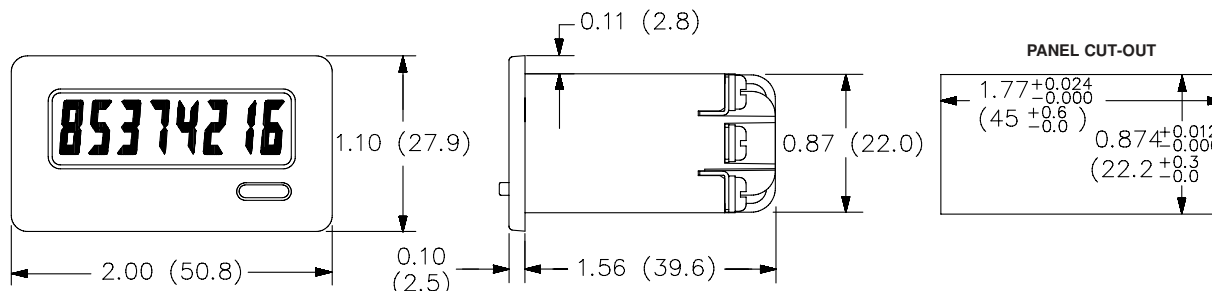

ELECTROMAGNETIC COMPATIBILITY

Immunity to EN 50082-2

Electrostatic discharge	EN 61000-4-2	Level 2; 4 Kv contact Level 3; 8 Kv air
Electromagnetic RF fields	EN 61000-4-3	Level 3; 10 V/m 80 MHz - 1 GHz
Fast transients (burst)	EN 61000-4-4	Level 4; 2 Kv I/O ¹ Level 3; 2 Kv power
RF conducted interference	EN 61000-4-6	Level 3; 10 V/rms ² 150 KHz - 80 MHz
Power frequency magnetic fields	EN 61000-4-8	Level 4; 30 A/m
Simulation of cordless telephone	ENV 50204	Level 3; 10 V/m 900 MHz ± 5 MHz 200 Hz, 50% duty cycle

Emissions to EN 50081-2

RF interference	EN 55011	Enclosure class B Power mains class B
-----------------	----------	--

Notes:

- Burst to DC backlight power had a power line filter installed RLC #LFIL0000 or equivalent at the unit.
- Self-recoverable loss of performance during EMI disturbance at 10 V/rms to backlight power lines.
LCD segments may flicker during EMI disturbance.

For operation without loss of performance:

Install power line filter RLC #LFIL0000 or equivalent at the unit.

Refer to the EMC Installation Guidelines section of this bulletin for additional information.

- CONSTRUCTION:** High impact plastic case with clear viewing window. The front panel meets NEMA 4X/IP65 requirements for indoor use when properly installed. Installation Category I, Pollution Degree 2. Panel gasket and mounting clip included.

- WEIGHT:** 2 oz. (57 grams) [with battery]

LOW SPEED COUNT INPUT, 30 Hz MAX.

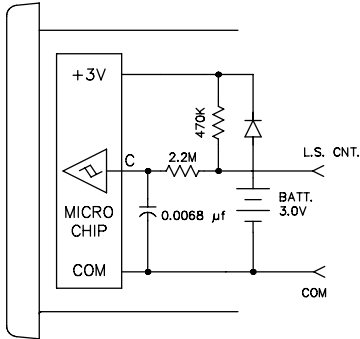

Pulling the "L.S. CNT." Input to Common with a mechanical or solid-state switch increments the counter. The low pass filter (2.2 MΩ resistor and 0.0068 µf capacitor) used with a Schmidt trigger circuit debounces mechanical switch signals. The switch load is 6 µA (max. voltage drop 0.5 V) when ON. The OFF-state leakage current must be less than 2 µA.

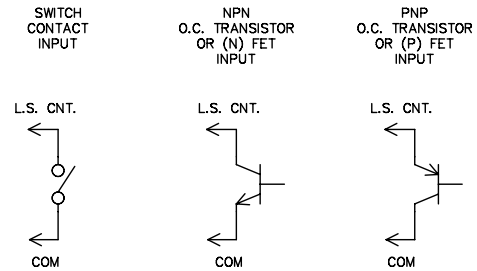

Reed switches, mercury wetted contacts, snap action limit switches, and silver alloy relay contacts with wiping action are usually satisfactory for generating count input signals. Motor starter contacts, tungsten contacts, and brush-type contacts should not be used.

HIGH SPEED COUNT INPUT, 10 KHz MAX.

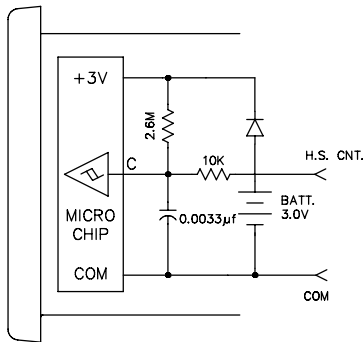

The "H.S. CNT." Input allows the CUB7 to operate at speeds up to 10 KHz when driven by bi-polar outputs or external circuits having an output impedance of 3.3 KΩ or less. Input drive voltage must be limited to 3 V maximum to avoid damage to the counter. CMOS and TTL Logic outputs can be loaded with a resistor (R_L) to limit drive voltage, or a voltage divider can be used as shown for the PNP O.C. Transistor output.

TTL OR CMOS OUTPUT

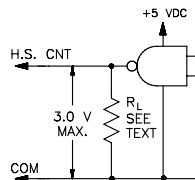

FIG 1

PNP O.C. TRANSISTOR OR BI-POLAR OUTPUT

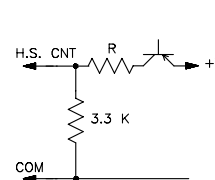

FIG 2

NPN O.C. TRANSISTOR

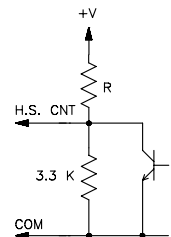

FIG 3

Note: The PSMA Power Supply and Interface Module used for powering RLC sensors with CUB Counters, has the proper interface output for direct drive to the H.S. CNT.

R values for Fig 2 & 3	
+V	R
+5 V	2.2 K
+12 V	10 K
+18 V	16 K
+24 V	24 K

RESET OPTIONS

Connecting a wire from the RST. EN. (Reset Enable) Input terminal to Common will enable the front panel Reset button.

Pulling the "RST." input low causes the counter to reset. The "RST." can be pulled low by either a mechanical switch or solid-state transistor switch. Switch load and leakage are the same as for "L.S. CNT." Input above.

Note: The RC protection circuit on the "RST." Input causes a delay of approximately 15 msec in Reset response.

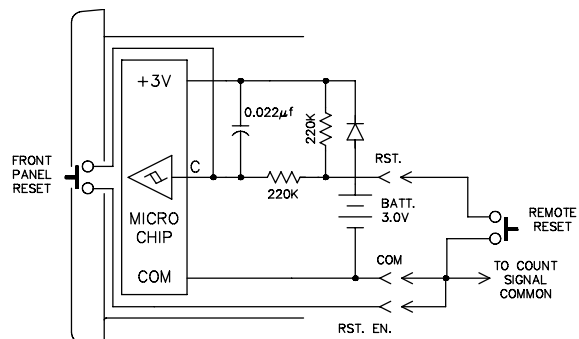

BACKLIGHT OPTION

Optional backlight versions of the CUB7 require an external 9-28 VDC power supply. The external supply is connected between V+ and Common terminals as shown in the drawing.

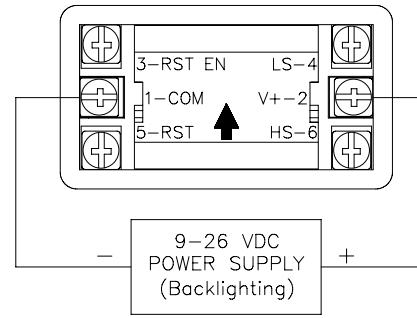

EMC INSTALLATION GUIDELINES

Although this unit is designed with a high degree of immunity to ElectroMagnetic Interference (EMI), proper installation and wiring methods must be followed to ensure compatibility in each application. The type of the electrical noise, source or coupling method into the unit may be different for various installations. In extremely high EMI environments, additional measures may be needed. The unit becomes more immune to EMI with fewer I/O connections. Cable length, routing and shield termination are very important and can mean the difference between a successful installation or a troublesome installation. Listed below are some EMC guidelines for successful installation in an industrial environment.

1. Use shielded (screened) cables for all Signal and Control inputs. The shield (screen) pigtail connection should be made as short as possible. The connection point for the shield depends somewhat upon the application. Listed below are the recommended methods of connecting the shield, in order of their effectiveness.
 - a. Connect the shield only at the panel where the unit is mounted to earth ground (protective earth).
 - b. Connect the shield to earth ground at both ends of the cable, usually when the noise source frequency is above 1 MHz.
 - c. Connect the shield to common of the unit and leave the other end of the shield unconnected and insulated from earth ground.
2. Never run Signal or Control cables in the same conduit or raceway with AC power lines, conductors feeding motors, solenoids, SCR controls, and heaters, etc. The cables should be run in metal conduit that is properly grounded. This is especially useful in applications where cable runs are long and portable two-way radios are used in close proximity or if the installation is near a commercial radio transmitter.
3. Signal or Control cables within an enclosure should be routed as far away as possible from contactors, control relays, transformers, and other noisy components.
4. In extremely high EMI environments, the use of external EMI suppression devices, such as ferrite suppression cores, is effective. Install them on Signal and Control cables as close to the unit as possible. Loop the cable through the core several times or use multiple cores on each cable for additional protection. Install line filters on the power input cable to the unit to suppress power line interference. Install them near the power entry point of the enclosure. The following EMI suppression devices (or equivalent) are recommended:

Ferrite Suppression Cores for signal and control cables:

Fair-Rite # 0443167251 (RLC #FCOR0000)
 TDK # ZCAT3035-1330A
 Steward #28B2029-0A0

Line Filters for input power cables:

Schaffner # FN610-1/07 (RLC #LFIL0000)
 Schaffner # FN670-1.8/07
 Corcom #1VR3

Note: Reference manufacturer's instructions when installing a line filter.

5. Long cable runs are more susceptible to EMI pickup than short cable runs. Therefore, keep cable runs as short as possible.

WIRING CONNECTIONS

The electrical connections are made via screw-clamp terminals located on the back of the unit. All conductors should meet voltage and current ratings for each terminal. Also cabling should conform to appropriate standards of good installation, local codes and regulations. It is recommended that power supplied to the unit (AC or DC) be protected by a fuse or circuit breaker. When wiring the unit, use the battery cover to identify the wire position with the proper function. Strip the wire, leaving approximately 1/4" bare wire exposed (stranded wires should be tinned with solder). Insert the wire under the screw-clamp and tighten down the screw until the wire is clamped in tightly. Each terminal can accept up to two #14 AWG wires.

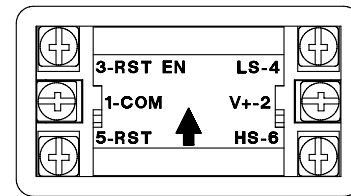

WARNING: Lithium battery may explode if incinerated. Signal input voltage should not exceed 3 VDC to prevent damage to the counter.

BATTERY INSTALLATION

1. Remove all power to the unit before removing battery cover.
2. To remove battery cover, push upward in the direction of the arrow on rear cover (See drawing at right), until the cover unlatches. Pull cover straight out from unit to fully remove.
3. Remove old battery* and replace with an RLC battery (BNL10000). Observe proper polarity when replacing battery as shown in drawing.
4. Replace cover. The battery cover is keyed so that it cannot be placed upside down. The arrow on the rear of the cover should point toward the top of the CUB7 when properly installed

* - Dispose of properly.

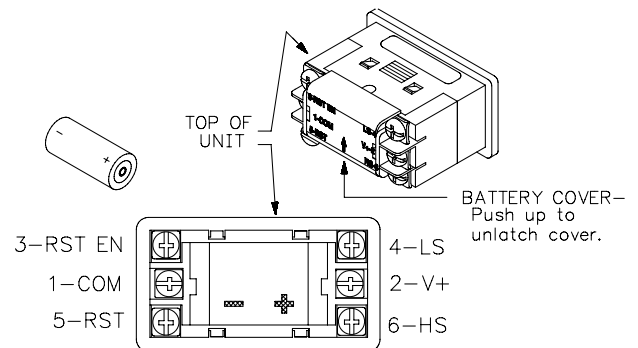

INSTALLATION ENVIRONMENT

The unit should be installed in a location that does not exceed the maximum operating temperature and provides good air circulation. Placing the unit near devices that generate excessive heat should be avoided.

The bezel should be cleaned only with a soft cloth and neutral soap product. Do NOT use solvents.

Continuous exposure to direct sunlight may accelerate the aging process of the bezel.

Do not use tools of any kind (screwdrivers, pens, pencils, etc.) to operate the keypad of the unit.

Installation

The CUB7 series of products meets NEMA 4X/IP65 requirements for indoor use, when properly installed. The units are intended to be mounted into an enclosed panel. The viewing window and reset button are factory sealed for a washdown environment. A sponge rubber gasket and mounting clip are provided for installing the unit in the panel cut-out.

The following procedure assures proper installation:

1. Cut panel opening to specified dimensions. Remove burrs and clean around panel opening.
2. Carefully remove and discard the center section of the gasket. Slide the panel gasket over the rear of the unit to the back of the bezel. Insert the mounting screws onto both sides of mounting clip. Tip of screw should **NOT** project from hole in mounting clip.
3. Install CUB7 unit through the panel cut-out until front bezel flange contacts the panel.
4. Slide the mounting clip over the rear of the unit until the clip is against the back of the panel. The mounting clip has latching features which engage into mating features on the CUB7 housing.

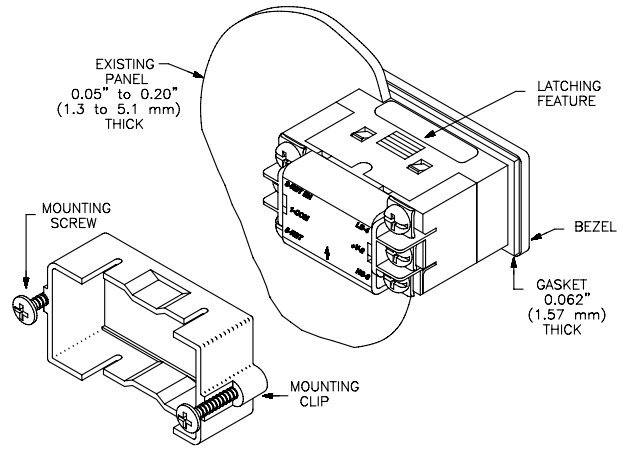

Note: It is necessary to hold the unit in place when sliding mounting clip into position.

5. Alternately tighten each screw to ensure uniform gasket pressure. Visually inspect the front panel gasket. The gasket should be compressed to about 75 to 80% of its original thickness. If not, gradually turn mounting screws to further compress gasket.
6. If gasket is not adequately compressed and the mounting screws can no longer be turned, loosen mounting screws, and check that mounting clip is latched as close as possible to the panel.
7. Repeat from step #5 for tightening mounting screws.

TROUBLESHOOTING

For further technical assistance, contact technical support at the appropriate company numbers listed.

ORDERING INFORMATION

MODEL NO.	DESCRIPTION	PART NUMBERS
*CUB7	Counter Positive Image Reflective	CUB70000
	Counter W/Yel-Grn Backlighting	CUB70010
	Counter W/Red Backlighting	CUB70020
BNL	3 V Lithium Battery	BNL10000

For more information on Pricing, Enclosures & Panel Mount Kits refer to the RLC Catalog or contact your local RLC distributor.

*Battery is included with unit.