

REVISIONS				
REV	ECO	DESCRIPTION	DATE	BY APPR
A1	-	RELEASED DRAWING	Jul-16-18	Flan Tommy

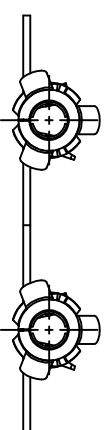
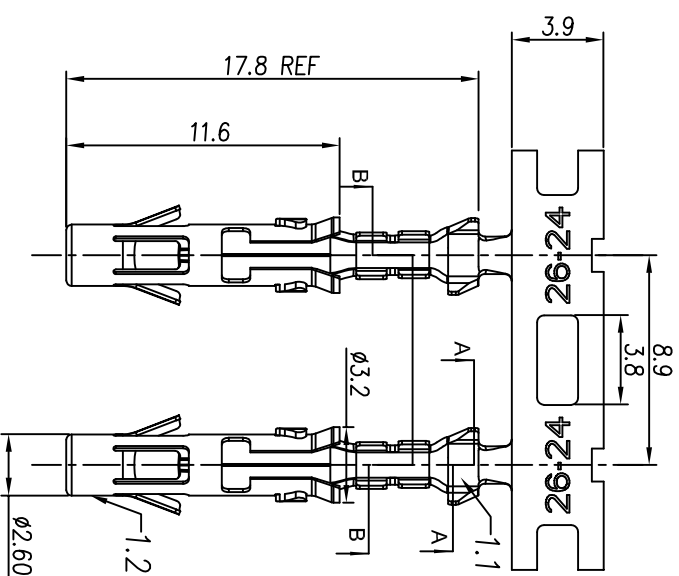
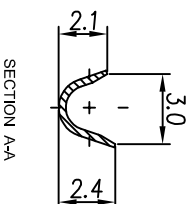
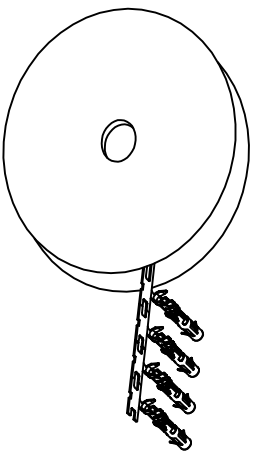

CONTACT ORIENTATION ON ROLL(3000PCS/COIL)

NOTES : (UNLESS OTHERWISE SPECIFIED)

1. MATERIAL :
  - 1.1. CONTACT BODY : COPPER ALLOY.
  - 1.2. OUTER SPRING : STAINLESS STEEL.
2. SPECIFICATIONS :
  - 2.1 CURRENT RATING : 13A MAX.
  - 2.2 TERMINATION TYPE : CRIMPING.
  - 2.3 WIRE RANGE : 26~24AWG.
  - 2.4 WIRE INSULATION DIA(MAX) :  $\phi$ 2.1mm.
3. ROHS COMPLIANT.
4. ALL DIMENSIONS ARE FOR REFERENCE USE ONLY.
5. AVAILABLE TOOLS :
  - 5.1 HAND CRIMPER : MFX-3954.
  - 5.2 CRIMP APPLICATOR : MFX-3957.
  - 5.3 EXTRACTION TOOL : QXRT16.

P/N	CONTACT PLATING(MATING AREA)
SS24M2T	TIN PLATING OVER NICKEL.
SS24M2N	NICKEL PLATING OVER COPPERIZE.
SS24M2F	GOLD FLASH PLATING OVER NICKEL.
SS24M2G5	5 $\mu$ "GOLD PLATING OVER NICKEL.
SS24M2G10	10 $\mu$ "GOLD PLATING OVER NICKEL.
SS24M2G15	15 $\mu$ "GOLD PLATING OVER NICKEL.
SS24M2G30	30 $\mu$ "GOLD PLATING OVER NICKEL.

QUANTITY	PART NUMBER	DESCRIPTION	ITEM
<b>MATERIALS LIST</b>			
UNLESS OTHERWISE SPECIFIED 1) All dimensions are in millimeters. 2) Tolerances are as follows: 1 PL DEC 20.30 Fractions .1"=4 3 PL DEC 20.08 Angles .1°			
SIGNATURES DATE DRAWN: Flan Jul-16-18 CHECKED: Tod Jul-16-18 ENGINEER: Tommy Jul-16-18 APPROVAL: Tommy Jul-16-18 CUSTOMER:		THIS DRAWING IS SUPERSEDED BY ANY LATER DATED DRAWINGS. SPECIFICATIONS AND PERFORMANCE DATA ARE SUBJECT TO CHANGE WITHOUT NOTICE. THE MANUFACTURING CORPORATION NO RIGHTS OF REPRODUCTION ARE GRANTED. ALL MANUFACTURING VARIATIONS SHALL BE ACCEPTED.	
MATERIAL SPECIFICATIONS: PROCESS SPECIFICATIONS: NEXT ASSY:		SIZE TYPE: B C- DWG NO: SS24M2XX SCALE: NONE SHEET 1 OF 1	
<b>Amphenol</b> Sine Systems - www.amphenol-sine.com 44724 Morley Drive Clinton Township, MI 48036 ECO-MATE SOCKET CONTACT, STAMPED, 26-24AWG, SIZE 16			