

LOC	DIST	REVISIONS					
		P	LTN	DESCRIPTION	DATE	OWN	APVD
	D			HOUSING RAW MATERIAL CHANGED TO LCP	18NOV2011	PS	RRP
	E			OBSOLETE 6339160-4	25JUL2013	CW	SH

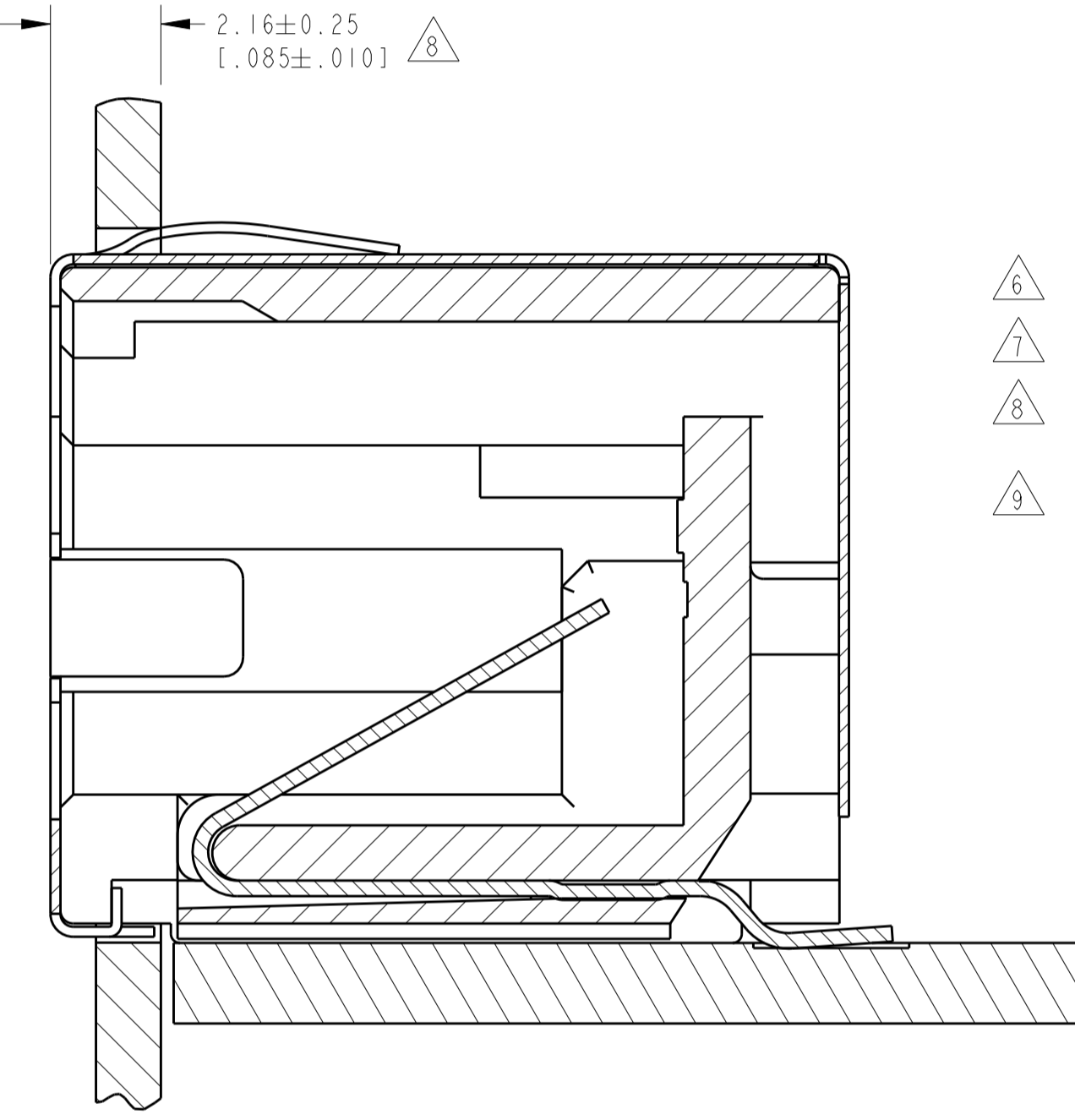

- MATERIAL:
 HOUSING - HIGH TEMP. THERMOPLASTIC - LCP. COLOR: SEE TABLE, UL94V-0.
 TERMINALS - 0.30 THICK PHOS BRONZE PLATED WITH 2.03µm MIN THICK MATTE TIN IN SOLDER AREA.
 GOLD (SEE TABLE) IN LOCALIZED PLATE AREA OVER 1.27µm MIN THICK NICKEL
 SHIELD - (SEE TABLE) 0.196 THK BRASS PREPLATED WITH 2.03µm-3.81µm THICK MATTE TIN OVER 0.76µm-2.03µm NICKEL UNDERPLATE, OR 0.76-2.03µm NICKEL WITH SELECTIVE TIN PLATED SOLDER TABS
 - JACK CAVITY CONFORMS TO FCC RULES AND REGULATIONS PART 68, SUBPART F.
- 3 SUGGESTED PANEL OPENING DIMENSIONS. SEE APPLICATION SPEC. 114-2154 FOR PANEL THICKNESS AND POSITION RECOMMENDATIONS
- 4 SUGGESTED CLEARANCE BETWEEN TOP OF CONNECTOR AND TOP PANEL OPENING
- 5 PACKAGED: POCKET TAPE & REEL (PER EIA 481 SPECIFICATIONS)
- POCKET TAPE WIDTH - 44mm
 POCKET PITCH - 24mm
 POCKET DEPTH - 16.7mm
- CLEAR COVER TAPE, PSA
 CLEAR COVER TAPE TRAILER - 1220mm, WRAPPED ON REEL HUB
 PLASTIC REEL - 381mm DIAMETER
 PRODUCT QUANTITY - 200 PIECES PER REEL
- 6 ZERO INSERTION FORCE POST WITH RECOMMENDED PCB LAYOUT
- 7 DATUM ESTABLISHED BY CUSTOMER.
- 8 CONNECTOR SHOULD BE POSITIONED THRU PANEL CUTOUT AS SHOWN TO SUPPORT TOP OF MODULAR JACK FOR STRAIN RELIEF.
- 9 MANUFACTURING DATE CODE LOCATED APPROXIMATELY AS SHOWN. FIRST 2 DIGITS ARE YEAR, SECOND 2 DIGITS ARE WORK WEEK, LAST DIGIT IS THE DAY OF THE WEEK

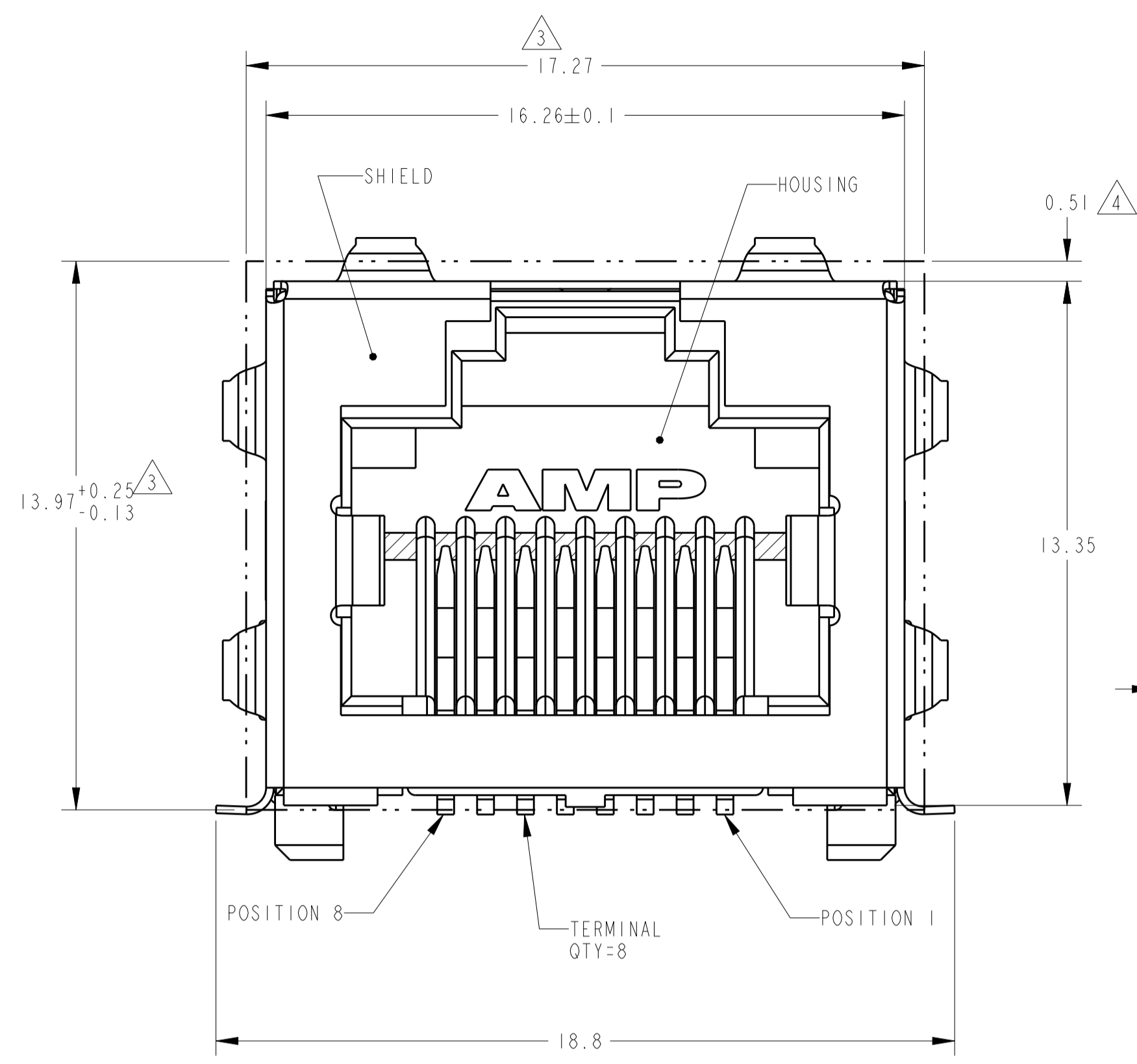
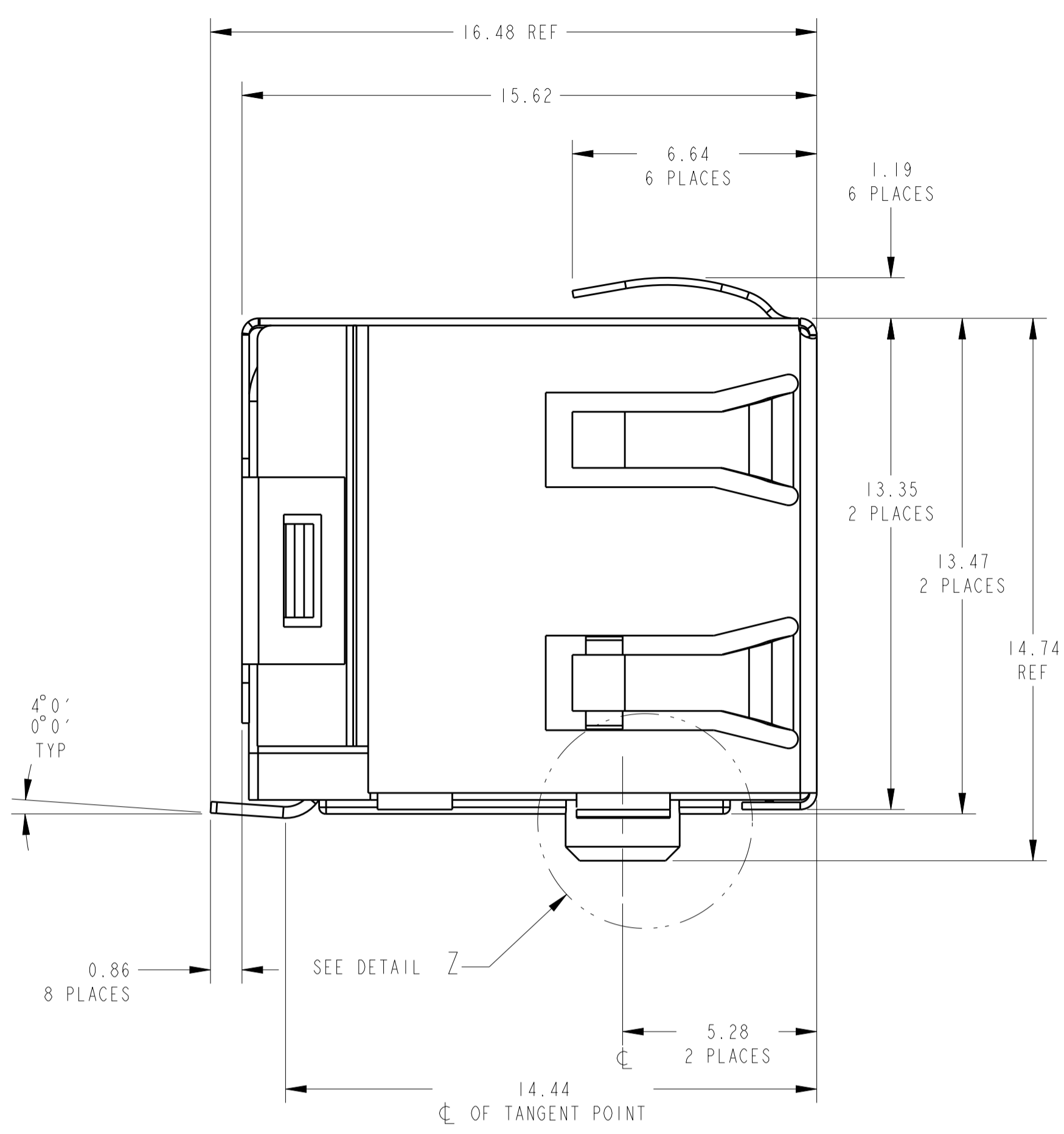
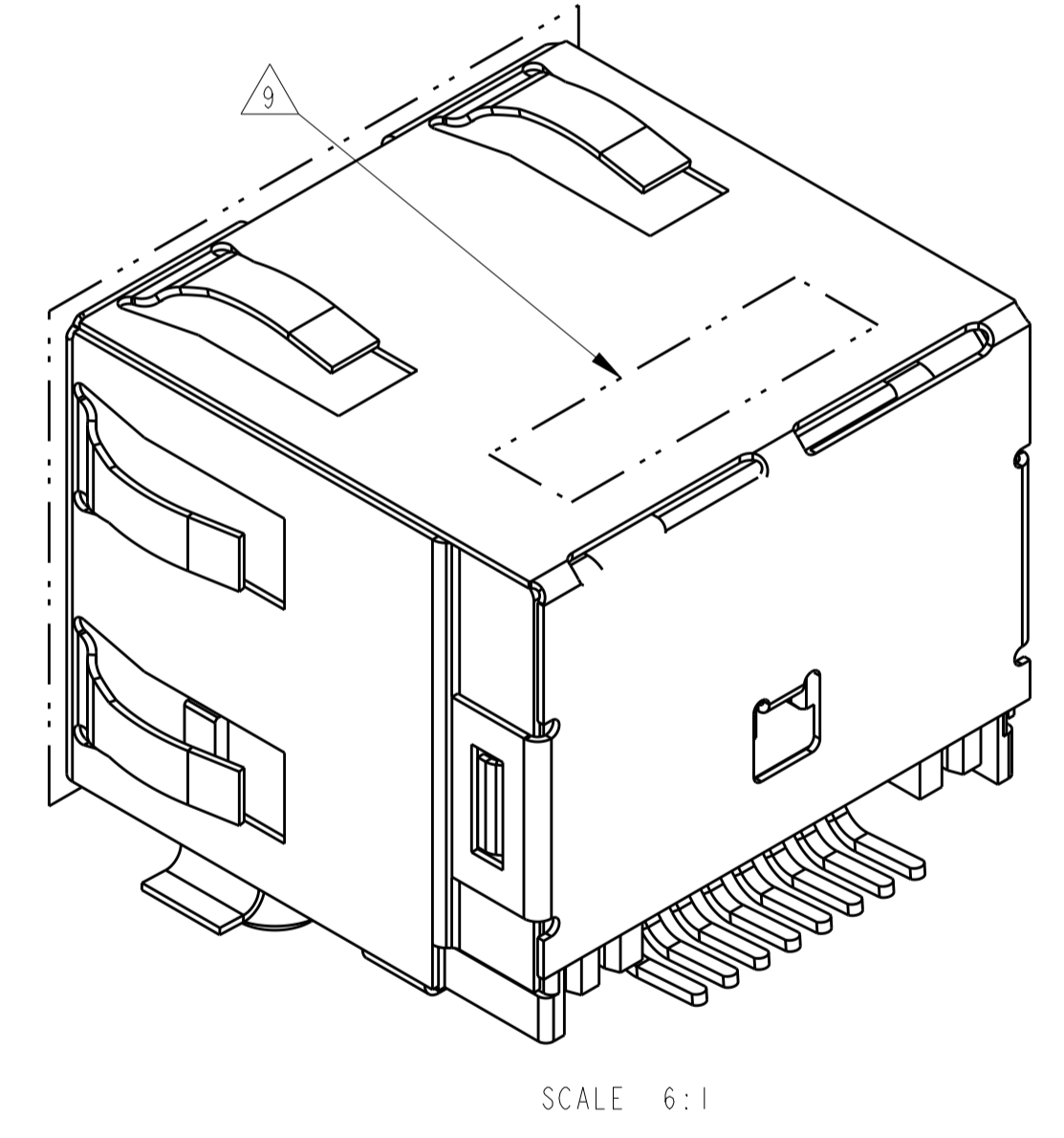
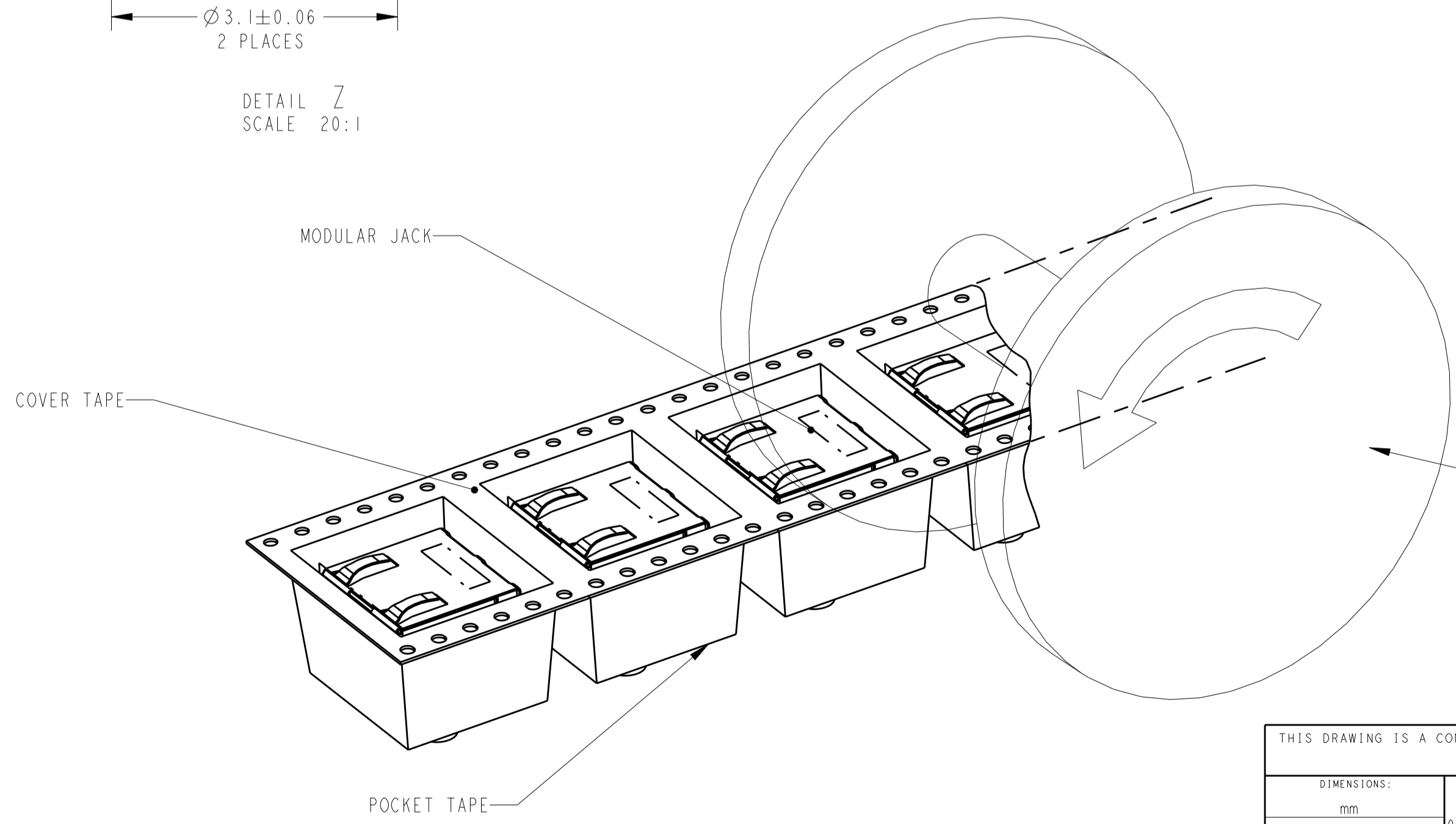
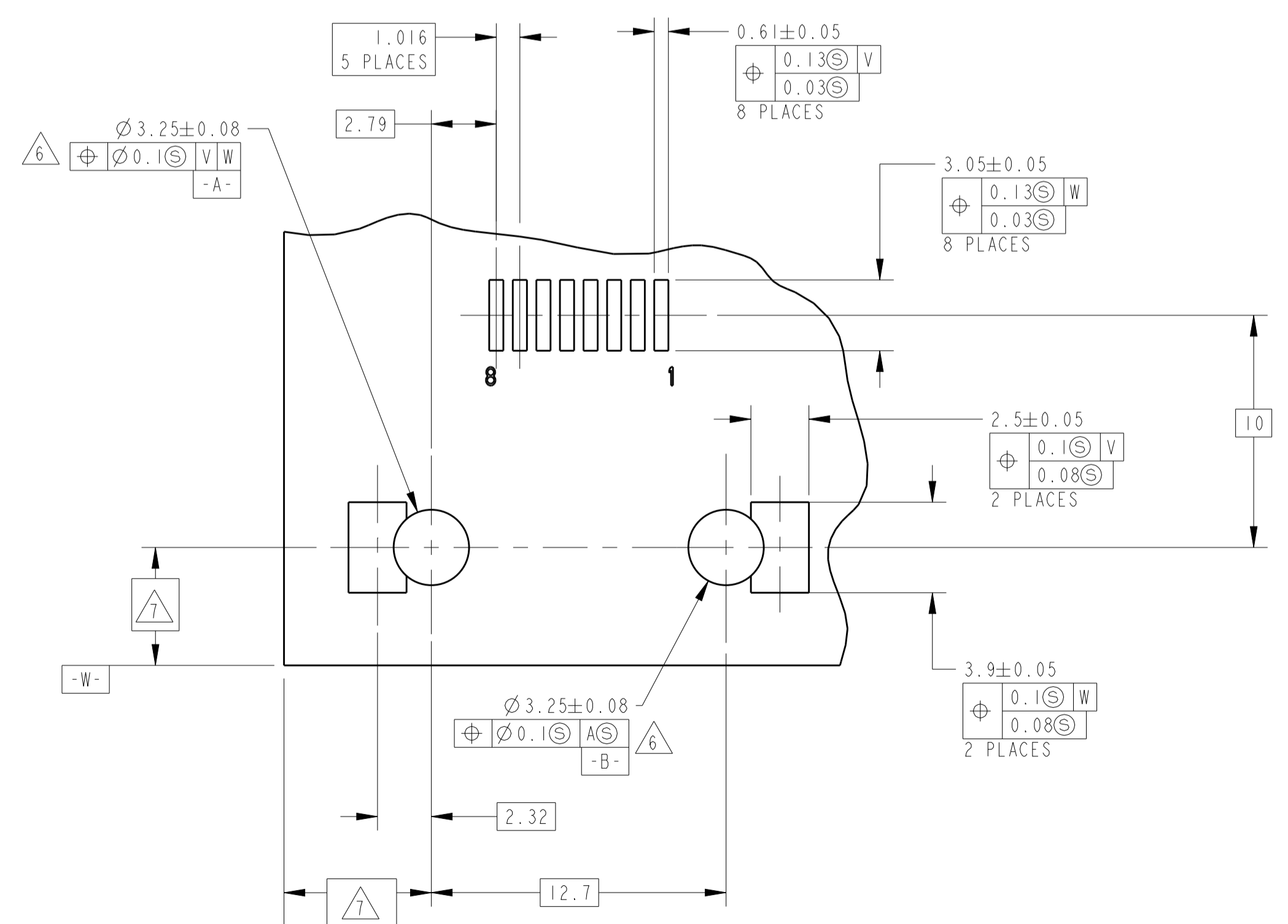
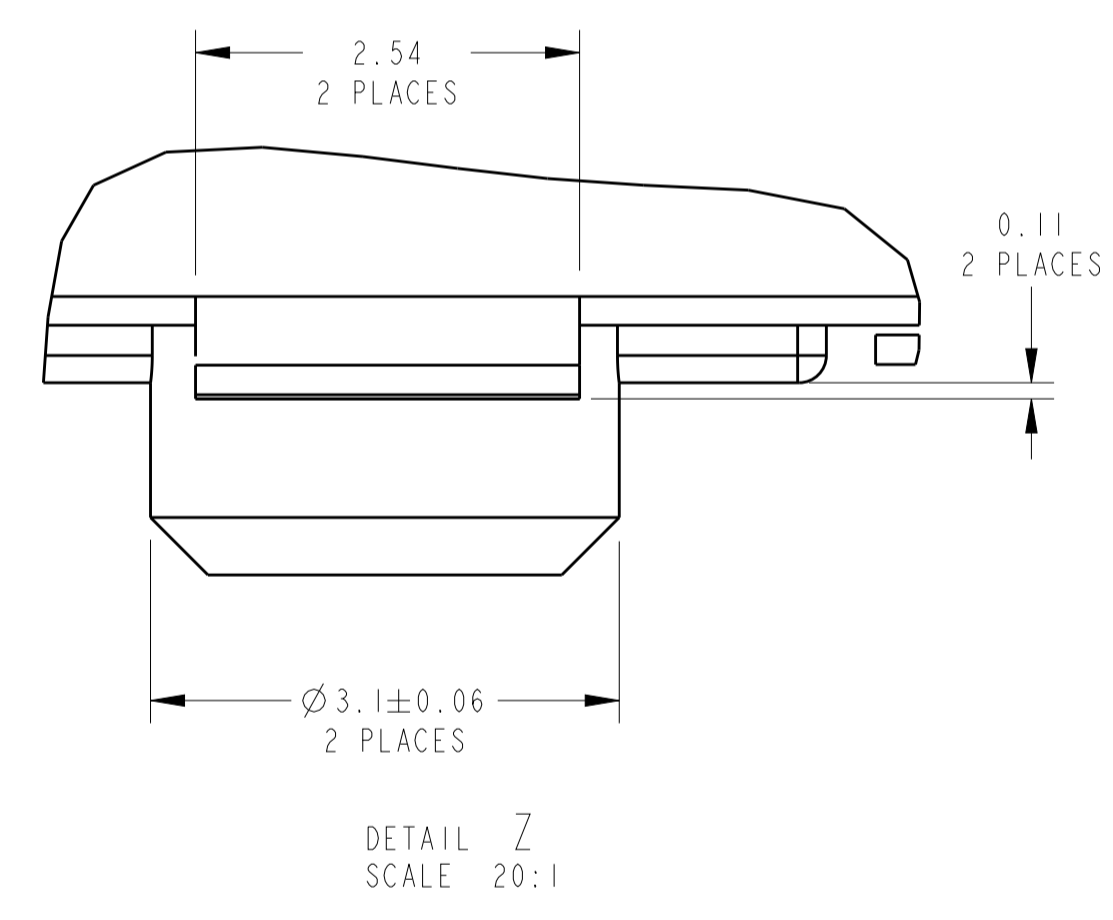

OBsolete	Gold Thickness	Shield Plating	Housing Color	Part Number
0.38µm	MATTE TIN	YELLOW	6339160-4	
0.76µm	MATTE TIN	YELLOW	6339160-3	
1.27µm	NICKEL	BLACK	6339160-2	
1.27µm	MATTE TIN	BLACK	6339160-1	

THIS DRAWING IS A CONTROLLED DOCUMENT.

OWN: D. WILLIS/J. A. MATYR 09MAY2005
 CHG: J. WESTMAN 09MAY2005
 APVD: S. FLICKINGER 09MAY2005

DIMENSIONS: mm
 TOLERANCES UNLESS OTHERWISE SPECIFIED:
 0 PLC ±
 1 PLC ±0.25
 2 PLC ±
 3 PLC ±
 4 PLC ±
 ANGLES ±

MATERIAL: SEE NOTE 1
 FINISH: SEE NOTE 1

Customer Drawing

NAME: INVERTED MOD JACK ASSEMBLY, 1X1, SHIELDED SURFACE MOUNT, 8 POSITION RJ45
 PRODUCT SPEC: 108-1163-7
 APPLICATION SPEC: 114-6040/114-2154

SIZE: A1
 CAGE CODE: 00779
 DRAWING NO: 6339160

RESTRICTED TO: E

SCALE: 8:1
 SHEET: 1 OF 1
 REV: E