

MAX19713

10-Bit, 45Mps, Full-Duplex Analog Front-End

General Description

The MAX19713 is an ultra-low-power, highly integrated mixed-signal analog front-end (AFE) ideal for wideband communication applications operating in full-duplex (FD) mode. Optimized for high dynamic performance and ultra-low power, the device integrates a dual 10-bit, 45Mps receive (Rx) ADC; dual 10-bit, 45Mps transmit (Tx) DAC; three fast-settling 12-bit aux-DAC channels for ancillary RF front-end control; and a 10-bit, 333ksps housekeeping aux-ADC. The typical operating power in FD mode is 91.8mW at a 45MHz clock frequency.

The Rx ADCs feature 54dB SINAD and 72.2dBc SFDR at 5.5MHz input frequency with a 45MHz clock frequency. The analog I/Q input amplifiers are fully differential and accept 1.024V_{P-P} full-scale signals. Typical I/Q channel matching is ± 0.03 phase and ± 0.02 dB gain.

The Tx DACs feature 70.3dBc SFDR at $f_{OUT} = 2.2$ MHz and $f_{CLK} = 45$ MHz. The analog I/Q full-scale output voltage range is ± 400 mV differential. The output DC common-mode voltage is selectable from 0.71V to 1.06V. The I/Q channel offset is adjustable to optimize radio lineup sideband/carrier suppression. Typical I/Q channel matching is ± 0.01 dB gain and $\pm 0.05^\circ$ phase.

Two independent 10-bit parallel, high-speed digital buses used by the Rx ADC and Tx DAC allow full-duplex operation for frequency-division duplex applications. The Rx ADC and Tx DAC can be disabled independently to optimize power management. A 3-wire serial interface controls power-management modes, the aux-DAC channels, and the aux-ADC channels.

The MAX19713 operates on a single 2.7V to 3.3V analog supply and 1.8V to 3.3V digital I/O supply. The MAX19713 is specified for the extended (-40°C to $+85^\circ\text{C}$) temperature range and is available in a 56-pin, TQFN package. The [Selector Guide](#) at the end of the data sheet lists other pin-compatible versions in this AFE family. For time-division duplex (TDD) applications, refer to the MAX19705–MAX19708 AFE family of products.

Applications

- WiMAX CPEs
- 801.11a/b/g WLAN
- VoIP Terminals
- Portable Communication Equipment

Ordering Information

| PART* | PIN-PACKAGE | PKG CODE |
|--------------|--------------|----------|
| MAX19713ETN | 56 TQFN-EP** | T5677-1 |
| MAX19713ETN+ | 56 TQFN-EP** | T5677-1 |

*All devices are specified over the -40°C to $+85^\circ\text{C}$ operating range.

**EP = Exposed paddle. +Denotes lead-free package.

Features

- Dual 10-Bit, 45Mps Rx ADC and Dual 10-Bit, 45Mps Tx DAC
- Ultra-Low Power
 - 91.8mW at $f_{CLK} = 45$ MHz, FD Mode
 - 79.2mW at $f_{CLK} = 45$ MHz, Slow Rx Mode
 - 49.5mW at $f_{CLK} = 45$ MHz, Slow Tx Mode
 - Low-Current Standby and Shutdown Modes
- Programmable Tx DAC Common-Mode DC Level and I/Q Offset Trim
- Excellent Dynamic Performance
 - SNR = 54.1dB at $f_{IN} = 5.5$ MHz (Rx ADC)
 - SFDR = 70.3dBc at $f_{OUT} = 2.2$ MHz (Tx DAC)
- Three 12-Bit, 1 μ s Aux-DACs
- 10-Bit, 333ksps Aux-ADC with 4:1 Input Mux and Data Averaging
- Excellent Gain/Phase Match
 - $\pm 0.03^\circ$ Phase, ± 0.02 dB Gain (Rx ADC) at $f_{IN} = 5.5$ MHz
- Multiplexed Parallel Digital I/O
- Serial-Interface Control
- Versatile Power-Control Circuits
 - Shutdown, Standby, Idle, Tx/Rx Disable
- Miniature 56-Pin TQFN Package (7mm x 7mm x 0.8mm)

Pin Configuration

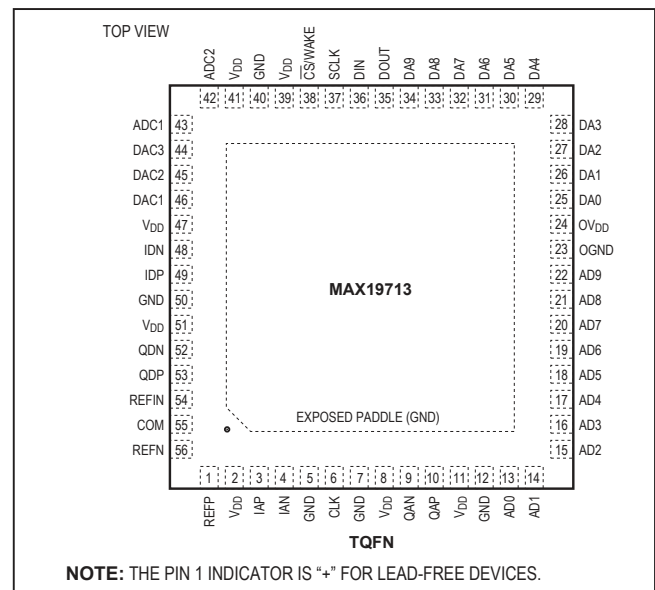

[Functional Diagram](#) and [Functional Diagram](#) appear at end of data sheet.



Absolute Maximum Ratings

V_{DD} to GND, OV_{DD} to OGND-0.3V to +3.6V
 GND to OGND.....-0.3V to +0.3V
 IAP, IAN, QAP, QAN, IDP, IDN, QDP,
 QDN, DAC1, DAC2, DAC3 to GND -0.3V to V_{DD}
 ADC1, ADC2 to GND -0.3V to (V_{DD} + 0.3V)
 REFP, REFN, REFIN, COM to GND..... -0.3V to (V_{DD} + 0.3V)
 AD0–AD9, DA0–DA9, SCLK, DIN, \overline{CS} /WAKE,
 CLK, DOUT to OGND -0.3V to (OV_{DD} + 0.3V)

Continuous Power Dissipation (T_A = +70°C)
 56-Pin TQFN-EP (derate 27.8mW/°C above +70°C).....2.22W
 Thermal Resistance θ_{JA}36°C/W
 Operating Temperature Range..... -40°C to +85°C
 Junction Temperature..... +150°C
 Storage Temperature Range..... -60°C to +150°C
 Lead Temperature (soldering, 10s) +300°C

Stresses beyond those listed under "Absolute Maximum Ratings" may cause permanent damage to the device. These are stress ratings only, and functional operation of the device at these or any other conditions beyond those indicated in the operational sections of the specifications is not implied. Exposure to absolute maximum rating conditions for extended periods may affect device reliability.

Electrical Characteristics

(V_{DD} = 3V, OV_{DD} = 1.8V, internal reference (1.024V), C_L ≈ 10pF on all digital outputs, f_{CLK} = 45MHz (50% duty cycle), Rx ADC input amplitude = -0.5dBFS, Tx DAC output amplitude = 0dBFS, CM1 = 0, CM0 = 0, differential Rx ADC input, differential Tx DAC output, C_{REFP} = C_{REFN} = C_{COM} = 0.33μF, C_L < 5pF on all aux-DAC outputs, T_A = T_{MIN} to T_{MAX}, unless otherwise noted. Typical values are at T_A = +25°C.) (Note 1)

| PARAMETER | SYMBOL | CONDITIONS | MIN | TYP | MAX | UNITS |
|--------------------------------|------------------|---------------------------------------------------------------------------------------------------------------------------------------------------------------------------|-----|------|-----------------|-------|
| POWER REQUIREMENTS | | | | | | |
| Analog Supply Voltage | V _{DD} | | 2.7 | 3.0 | 3.3 | V |
| Output Supply Voltage | OV _{DD} | | 1.8 | | V _{DD} | V |
| V _{DD} Supply Current | | FD mode: f _{CLK} = 45MHz, f _{OUT} = 2.2MHz on both DAC channels; f _{IN} = 5.5MHz on both ADC channels; aux-DACs ON and at midscale, aux-ADC ON | | 31.9 | 37 | mA |
| | | SPI2-Tx mode: f _{CLK} = 45MHz, f _{OUT} = 2.2MHz on both DAC channels; Rx ADC OFF; aux-DACs ON and at midscale, aux-ADC ON | | 16.7 | 19 | |
| | | SPI1-Rx mode: f _{CLK} = 45MHz, f _{IN} = 5.5MHz on both ADC channels; Tx DAC OFF (Tx DAC outputs at 0V); aux-DACs ON and at midscale, aux-ADC ON | | 27.6 | 32 | |
| | | SPI4-Tx mode: f _{CLK} = 45MHz, f _{OUT} = 2.2MHz on both DAC channels; Rx ADC ON (output three-stated); aux-DACs ON and at midscale, aux-ADC ON | | 31.0 | 36 | |
| | | SPI3-Rx mode: f _{CLK} = 45MHz, f _{IN} = 5.5MHz on both channels; Tx DAC ON (Tx DAC outputs at midscale); aux-DACs ON and at midscale, aux-ADC ON | | 30.2 | 35 | |
| | | Standby mode: CLK = 0 or OV _{DD} ; aux-DACs ON and at midscale, aux-ADC ON | | 3.3 | 5 | |

Electrical Characteristics (continued)

($V_{DD} = 3V$, $OV_{DD} = 1.8V$, internal reference (1.024V), $C_L \approx 10pF$ on all digital outputs, $f_{CLK} = 45MHz$ (50% duty cycle), Rx ADC input amplitude = -0.5dBFS, Tx DAC output amplitude = 0dBFS, $CM1 = 0$, $CM0 = 0$, differential Rx ADC input, differential Tx DAC output, $C_{REFP} = C_{REFN} = C_{COM} = 0.33\mu F$, $C_L < 5pF$ on all aux-DAC outputs, $T_A = T_{MIN}$ to T_{MAX} , unless otherwise noted. Typical values are at $T_A = +25^\circ C$.) (Note 1)

| PARAMETER | SYMBOL | CONDITIONS | MIN | TYP | MAX | UNITS |
|---------------------------------|----------|--------------------------------------------------------------------------------------------------------------------------------------------------------------|-------|-------------|-------|-----------------|
| V_{DD} Supply Current | | Idle mode: $f_{CLK} = 45MHz$; aux-DACs ON and at midscale, aux-ADC ON | | 12.4 | 15 | mA |
| | | Shutdown mode: $CLK = 0$ or OV_{DD} , aux-ADC OFF | | 0.5 | 5 | μA |
| OV_{DD} Supply Current | | FD mode: $f_{CLK} = 45MHz$, $f_{OUT} = 2.2MHz$ on both DAC channels; $f_{IN} = 5.5MHz$ on both ADC channels; aux-DACs ON and at midscale, aux-ADC ON | | 4.6 | | mA |
| | | SPI1-Rx and SPI3-Rx modes: $f_{CLK} = 45MHz$, $f_{IN} = 5.5MHz$ on both ADC channels; DAC input bus three-stated; aux-DACs ON and at midscale, aux-ADC ON | | 4.35 | | |
| | | SPI2-Tx and SPI4-Tx modes: $f_{CLK} = 45MHz$, $f_{OUT} = 2.2MHz$ on both DAC channels; ADC output bus three-stated; aux-DACs ON and at midscale, aux-ADC ON | | 310 | | μA |
| | | Standby mode: $CLK = 0$ or OV_{DD} ; aux-DACs ON and at midscale, aux-ADC ON | | 0.1 | | |
| | | Idle mode: $f_{CLK} = 45MHz$; aux-DACs ON and at midscale, aux-ADC ON | | 73 | | |
| | | Shutdown mode: $CLK = 0$ or OV_{DD} , aux-ADC OFF | | 0.1 | | |
| Rx ADC DC ACCURACY | | | | | | |
| Resolution | | | 10 | | | Bits |
| Integral Nonlinearity | INL | | | ± 1.25 | | LSB |
| Differential Nonlinearity | DNL | | | ± 0.65 | | LSB |
| Offset Error | | Residual DC offset error | -5 | ± 0.2 | +5 | %FS |
| Gain Error | | Includes reference error | -5 | ± 0.7 | +5 | %FS |
| DC Gain Matching | | | -0.15 | ± 0.04 | +0.15 | dB |
| Offset Matching | | | | ± 10 | | LSB |
| Gain Temperature Coefficient | | | | ± 30 | | ppm/ $^\circ C$ |
| Power-Supply Rejection | | Offset ($V_{DD} \pm 5\%$) | | ± 0.2 | | LSB |
| | | Gain ($V_{DD} \pm 5\%$) | | ± 0.07 | | |
| Rx ADC ANALOG INPUT | | | | | | |
| Input Differential Range | V_{ID} | Differential or single-ended inputs | | ± 0.512 | | V |
| Input Common-Mode Voltage Range | V_{CM} | | | $V_{DD}/2$ | | V |
| Input Impedance | R_{IN} | Switched capacitor load | | 120 | | k Ω |
| | C_{IN} | | | 5 | | pF |

Electrical Characteristics (continued)

($V_{DD} = 3V$, $OV_{DD} = 1.8V$, internal reference (1.024V), $C_L \approx 10pF$ on all digital outputs, $f_{CLK} = 45MHz$ (50% duty cycle), Rx ADC input amplitude = -0.5dBFS, Tx DAC output amplitude = 0dBFS, $CM1 = 0$, $CM0 = 0$, differential Rx ADC input, differential Tx DAC output, $C_{REFP} = C_{REFN} = C_{COM} = 0.33\mu F$, $C_L < 5pF$ on all aux-DAC outputs, $T_A = T_{MIN}$ to T_{MAX} , unless otherwise noted. Typical values are at $T_A = +25^\circ C$.) (Note 1)

| PARAMETER | SYMBOL | CONDITIONS | MIN | TYP | MAX | UNITS |
|------------------------------------------------|-----------|-------------------------------------------------------------------------------------------------------|-------|------------|------|-------------------|
| Rx ADC CONVERSION RATE | | | | | | |
| Maximum Clock Frequency | f_{CLK} | (Note 2) | | | 45 | MHz |
| Data Latency | | Channel IA | | 5 | | Clock Cycles |
| | | Channel QA | | 5.5 | | |
| Rx ADC DYNAMIC CHARACTERISTICS (Note 3) | | | | | | |
| Signal-to-Noise Ratio | SNR | $f_{IN} = 5.5MHz$ | 52.7 | 54.5 | | dB |
| | | $f_{IN} = 19.4MHz$ | | 54 | | |
| Signal-to-Noise and Distortion | SINAD | $f_{IN} = 5.5MHz$ | 52.4 | 54.3 | | dB |
| | | $f_{IN} = 19.4MHz$ | | 53.9 | | |
| Spurious-Free Dynamic Range | SFDR | $f_{IN} = 5.5MHz$ | 63 | 72.1 | | dBc |
| | | $f_{IN} = 19.4MHz$ | | 76.3 | | |
| Total Harmonic Distortion | THD | $f_{IN} = 5.5MHz$ | -69.4 | -61 | | dBc |
| | | $f_{IN} = 19.4MHz$ | | -71.3 | | |
| Third-Harmonic Distortion | HD3 | $f_{IN} = 5.5MHz$ | | -73.7 | | dBc |
| | | $f_{IN} = 19.4MHz$ | | -76.3 | | |
| Intermodulation Distortion | IMD | $f_{IN1} = 1.8MHz, A_{IN1} = -7dBFS,$ $f_{IN2} = 1.0MHz, A_{IN2} = -7dBFS$ | | -69 | | dBc |
| Third-Order Intermodulation Distortion | IM3 | $f_{IN1} = 1.8MHz, A_{IN1} = -7dBFS,$ $f_{IN2} = 1.0MHz, A_{IN2} = -7dBFS$ | | -72 | | dBc |
| Aperture Delay | | | | 3.5 | | ns |
| Aperture Jitter | | | | 2 | | ps _{RMS} |
| Overdrive Recovery Time | | 1.5x full-scale input | | 2 | | ns |
| Rx ADC INTERCHANNEL CHARACTERISTICS | | | | | | |
| Crosstalk Rejection | | $f_{INX,Y} = 5.5MHz, A_{INX,Y} = -0.5dBFS,$ $f_{INY,X} = 1.8MHz, A_{INY,X} = -0.5Dbfs$ (Note 4) | | -88 | | dB |
| Amplitude Matching | | $f_{IN} = 5.5MHz, A_{IN} = -0.5dBFS$ (Note 5) | | ± 0.02 | | dB |
| Phase Matching | | $f_{IN} = 5.5MHz, A_{IN} = -0.5dBFS$ (Note 5) | | ± 0.03 | | Degrees |
| Tx DAC DC ACCURACY | | | | | | |
| Resolution | N | | 10 | | | Bits |
| Integral Nonlinearity | INL | | | ± 0.35 | | LSB |
| Differential Nonlinearity | DNL | Guaranteed monotonic (Note 6) | -0.7 | ± 0.2 | +0.7 | LSB |
| Residual DC Offset | V_{OS} | | -4 | ± 0.1 | +4 | mV |
| Full-Scale Gain Error | | | -40 | | +40 | mV |

Electrical Characteristics (continued)

($V_{DD} = 3V$, $OV_{DD} = 1.8V$, internal reference (1.024V), $C_L \approx 10pF$ on all digital outputs, $f_{CLK} = 45MHz$ (50% duty cycle), Rx ADC input amplitude = -0.5dBFS, Tx DAC output amplitude = 0dBFS, $CM1 = 0$, $CM0 = 0$, differential Rx ADC input, differential Tx DAC output, $C_{REFP} = C_{REFN} = C_{COM} = 0.33\mu F$, $C_L < 5pF$ on all aux-DAC outputs, $T_A = T_{MIN}$ to T_{MAX} , unless otherwise noted. Typical values are at $T_A = +25^\circ C$.) (Note 1)

| PARAMETER | SYMBOL | CONDITIONS | MIN | TYP | MAX | UNITS |
|---------------------------------------------------|------------|----------------------------------------------------------------------------|------|----------------|-------|------------|
| Tx DAC DYNAMIC PERFORMANCE | | | | | | |
| DAC Conversion Rate | f_{CLK} | (Note 2) | | | 45 | MHz |
| In-Band Noise Density | N_D | $f_{OUT} = 2.2MHz$ | | -129 | | dBFS/Hz |
| Third-Order Intermodulation Distortion | IM3 | $f_{OUT1} = 2MHz$, $f_{OUT2} = 2.2MHz$ | | -82 | | dBc |
| Glitch Impulse | | | | 10 | | pV*s |
| Spurious-Free Dynamic Range to Nyquist | SFDR | $f_{OUT} = 2.2MHz$ | 61.5 | 70.3 | | dBc |
| Total Harmonic Distortion to Nyquist | THD | $f_{OUT} = 2.2MHz$ | | -68.1 | -60.5 | dBc |
| Signal-to-Noise Ratio to Nyquist | SNR | $f_{OUT} = 2.2MHz$ | | 56.1 | | dB |
| Tx DAC INTERCHANNEL CHARACTERISTICS | | | | | | |
| I-to-Q Output Isolation | | $f_{OUTX,Y} = 500kHz$, $f_{OUTY,X} = 620kHz$ | | 85 | | dB |
| Gain Mismatch Between I and Q Channels | | Measured at DC | -0.4 | ± 0.01 | +0.4 | dB |
| Phase Mismatch Between I and Q Channels | | $f_{OUT} = 2.2MHz$ | | ± 0.05 | | Degrees |
| Differential Output Impedance | | | | 800 | | Ω |
| Tx DAC ANALOG OUTPUT | | | | | | |
| Full-Scale Output Voltage | V_{FS} | | | ± 400 | | mV |
| Output Common-Mode Voltage | V_{COMD} | Bits $CM1 = 0$, $CM0 = 0$ (default) | 1.01 | 1.06 | 1.11 | V |
| | | Bits $CM1 = 0$, $CM0 = 1$ | 0.88 | 0.94 | 1.00 | |
| | | Bits $CM1 = 1$, $CM0 = 0$ | 0.75 | 0.82 | 0.90 | |
| | | Bits $CM1 = 1$, $CM0 = 1$ | 0.62 | 0.71 | 0.81 | |
| Rx ADC–Tx DAC INTERCHANNEL CHARACTERISTICS | | | | | | |
| Receive Transmit Isolation | | ADC: $f_{INI} = f_{INQ} = 5.5MHz$, DAC: $f_{OUTI} = f_{OUTQ} = 2.2MHz$ | | 85 | | dB |
| AUXILIARY ADCs (ADC1, ADC2) | | | | | | |
| Resolution | N | | 10 | | | Bits |
| Full-Scale Reference | V_{REF} | AD1 = 0 (default) | | 2.048 | | V |
| | | AD1 = 1 | | V_{DD} | | |
| Analog Input Range | | | | 0 to V_{REF} | | V |
| Analog Input Impedance | | Measured at DC | | 500 | | k Ω |
| Input-Leakage Current | | Measured at unselected input from 0 to V_{REF} | | ± 0.1 | | μA |
| Gain Error | GE | Includes reference error, AD1 = 0 | -5 | | +5 | %FS |
| Zero-Code Error | ZE | | | ± 2 | | mV |
| Differential Nonlinearity | DNL | | | ± 0.6 | | LSB |

Electrical Characteristics (continued)

($V_{DD} = 3V$, $OV_{DD} = 1.8V$, internal reference (1.024V), $C_L \approx 10pF$ on all digital outputs, $f_{CLK} = 45MHz$ (50% duty cycle), Rx ADC input amplitude = -0.5dBFS, Tx DAC output amplitude = 0dBFS, $CM1 = 0$, $CM0 = 0$, differential Rx ADC input, differential Tx DAC output, $C_{REFP} = C_{REFN} = C_{COM} = 0.33\mu F$, $C_L < 5pF$ on all aux-DAC outputs, $T_A = T_{MIN}$ to T_{MAX} , unless otherwise noted. Typical values are at $T_A = +25^\circ C$.) (Note 1)

| PARAMETER | SYMBOL | CONDITIONS | MIN | TYP | MAX | UNITS |
|--------------------------------------------------------------------------|-----------|----------------------------------------------------------|------|-------|------|-------|
| Integral Nonlinearity | INL | | | ±0.6 | | LSB |
| Supply Current | | | | 210 | | μA |
| AUXILIARY DACs (DAC1, DAC2, DAC3) | | | | | | |
| Resolution | N | | 12 | | | Bits |
| Integral Nonlinearity | INL | From code 100 to code 4000 | | ±1.25 | | LSB |
| Differential Nonlinearity | DNL | Guaranteed monotonic over code 100 to code 4000 (Note 6) | -1.0 | ±0.65 | +1.2 | LSB |
| Output-Voltage Low | V_{OL} | $R_L > 200k\Omega$ | | | 0.2 | V |
| Output-Voltage High | V_{OH} | $R_L > 200k\Omega$ | 2.57 | | | V |
| DC Output Impedance | | DC output at midscale | | 4 | | Ω |
| Settling Time | | From code 1024 to code 3072, within ±10 LSB | | 1 | | μs |
| Glitch Impulse | | From code 0 to code 4095 | | 24 | | nV*s |
| Rx ADC–Tx DAC TIMING CHARACTERISTICS | | | | | | |
| CLK Rise to Channel-I Output Data Valid | t_{DOI} | Figure 3 (Note 6) | 5.5 | 8.2 | 12.5 | ns |
| CLK Fall to Channel-Q Output Data Valid | t_{DOQ} | Figure 3 (Note 6) | 6.5 | 9.5 | 13.6 | ns |
| I-DAC DATA to CLK Fall Setup Time | t_{DSI} | Figure 5 (Note 6) | 10 | | | ns |
| Q-DAC DATA to CLK Rise Setup Time | t_{DSQ} | Figure 5 (Note 6) | 10 | | | ns |
| CLK Fall to I-DAC Data Hold Time | t_{DHI} | Figure 5 (Note 6) | 0 | | | ns |
| CLK Rise to Q-DAC Data Hold Time | t_{DHQ} | Figure 5 (Note 6) | 0 | | | ns |
| CLK Duty Cycle | | | | 50 | | % |
| CLK Duty-Cycle Variation | | | | ±10 | | % |
| Digital Output Rise/Fall Time | | 20% to 80% | | 2.4 | | ns |
| SERIAL-INTERFACE TIMING CHARACTERISTICS (Figures 6 and 8, Note 6) | | | | | | |
| Falling Edge of $\overline{CS}/WAKE$ to Rising Edge of First SCLK Time | t_{CSS} | | 10 | | | ns |
| DIN to SCLK Setup Time | t_{DS} | | 10 | | | ns |
| DIN to SCLK Hold Time | t_{DH} | | 0 | | | ns |
| SCLK Pulse-Width High | t_{CH} | | 25 | | | ns |
| SCLK Pulse-Width Low | t_{CL} | | 25 | | | ns |
| SCLK Period | t_{CP} | | 50 | | | ns |
| SCLK to $\overline{CS}/WAKE$ Setup Time | t_{CS} | | 10 | | | ns |
| $\overline{CS}/WAKE$ High Pulse Width | t_{CSW} | | 80 | | | ns |
| $\overline{CS}/WAKE$ High to DOUT Active High | t_{CSD} | Bit AD0 set | | 200 | | ns |

Electrical Characteristics (continued)

($V_{DD} = 3V$, $OV_{DD} = 1.8V$, internal reference (1.024V), $C_L \approx 10pF$ on all digital outputs, $f_{CLK} = 45MHz$ (50% duty cycle), Rx ADC input amplitude = -0.5dBFS, Tx DAC output amplitude = 0dBFS, $CM1 = 0$, $CM0 = 0$, differential Rx ADC input, differential Tx DAC output, $C_{REFP} = C_{REFN} = C_{COM} = 0.33\mu F$, $C_L < 5pF$ on all aux-DAC outputs, $T_A = T_{MIN}$ to T_{MAX} , unless otherwise noted. Typical values are at $T_A = +25^\circ C$.) (Note 1)

| PARAMETER | SYMBOL | CONDITIONS | MIN | TYP | MAX | UNITS |
|-----------------------------------------------------------------|-----------------|-----------------------------------------------------------------------------------------------|-----|------|------|---------|
| $\overline{CS}/WAKE$ High to DOUT Low (Aux-ADC Conversion Time) | t_{CONV} | Bit AD0 set, no averaging, $f_{CLK} = 45MHz$, CLK divider = 16 | | 4.3 | | μs |
| DOUT Low to $\overline{CS}/WAKE$ Setup Time | t_{DCS} | Bit AD0, AD10 set | | 200 | | ns |
| SCLK Low to DOUT Data Out | t_{CD} | Bit AD0, AD10 set | | | 14.5 | ns |
| $\overline{CS}/WAKE$ High to DOUT High Impedance | t_{CHZ} | Bit AD0, AD10 set | | 200 | | ns |
| MODE-RECOVERY TIMING CHARACTERISTICS (Figure 7) | | | | | | |
| Shutdown Wake-Up Time | $t_{WAKE,SD}$ | From shutdown to Rx mode, ADC settles to within 1dB SINAD | | 500 | | μs |
| | | From shutdown to Tx mode, DAC settles to within 10 LSB error | | 26.4 | | |
| | | From aux-ADC enable to aux-ADC start conversion | | 10 | | |
| | | From shutdown to aux-DAC output valid | | 28 | | |
| | | From shutdown to FD mode, ADC settles to within 1dB SINAD, DAC settles to within 10 LSB error | | 500 | | |
| Idle Wake-Up Time (With CLK) | $t_{WAKE,ST0}$ | From idle to Rx mode with CLK present during idle, ADC settles to within 1dB SINAD | | 3.7 | | μs |
| | | From idle to Tx mode with CLK present during idle, DAC settles to 10 LSB error | | 5.1 | | |
| | | From idle to FD mode, ADC settles to within 1dB SINAD, DAC settles to within 10 LSB error | | 5.1 | | |
| Standby Wake-Up Time | $t_{WAKE,ST1}$ | From standby to Rx mode, ADC settles to within 1dB SINAD | | 3.8 | | μs |
| | | From standby to Tx mode, DAC settles to 10 LSB error | | 24.4 | | |
| | | From standby to FD mode, ADC settles to within 1dB SINAD, DAC settles to within 10 LSB error | | 24.4 | | |
| Enable Time from Tx to Rx, Fast Mode | $t_{ENABLE,RX}$ | ADC settles to within 1dB SINAD | | 0.1 | | μs |
| Enable Time from Rx to Tx, Fast Mode | $t_{ENABLE,TX}$ | DAC settles to within 10 LSB error | | 0.1 | | μs |
| Enable Time from Tx to Rx, Slow Mode | $t_{ENABLE,RX}$ | ADC settles to within 1dB SINAD | | 3.7 | | μs |

Electrical Characteristics (continued)

($V_{DD} = 3V$, $OV_{DD} = 1.8V$, internal reference (1.024V), $C_L \approx 10pF$ on all digital outputs, $f_{CLK} = 45MHz$ (50% duty cycle), Rx ADC input amplitude = -0.5dBFS, Tx DAC output amplitude = 0dBFS, $CM1 = 0$, $CM0 = 0$, differential Rx ADC input, differential Tx DAC output, $C_{REFP} = C_{REFN} = C_{COM} = 0.33\mu F$, $C_L < 5pF$ on all aux-DAC outputs, $T_A = T_{MIN}$ to T_{MAX} , unless otherwise noted. Typical values are at $T_A = +25^\circ C$.) (Note 1)

| PARAMETER | SYMBOL | CONDITIONS | MIN | TYP | MAX | UNITS |
|-------------------------------------------------------------------------------------------------------------------------------------------------------------------------------------------|-----------------|----------------------------------------------------------|-------------------|-----------------|-------------------|-----------------|
| Enable Time from Rx to Tx, Slow Mode | $t_{ENABLE,TX}$ | DAC settles to within 10 LSB error | | 4.9 | | μs |
| INTERNAL REFERENCE ($V_{REFIN} = V_{DD}$; V_{REFP}, V_{REFN}, V_{COM} levels are generated internally) | | | | | | |
| Positive Reference | | $V_{REFP} - V_{COM}$ | | 0.256 | | V |
| Negative Reference | | $V_{REFN} - V_{COM}$ | | -0.256 | | V |
| Common-Mode Output Voltage | V_{COM} | | $V_{DD}/2 - 0.15$ | $V_{DD}/2$ | $V_{DD}/2 + 0.15$ | V |
| Maximum REFP/REFN/COM Source Current | I_{SOURCE} | | | 2 | | mA |
| Maximum REFP/REFN/COM Sink Current | I_{SINK} | | | 2 | | mA |
| Differential Reference Output | V_{REF} | $V_{REFP} - V_{REFN}$ | +0.490 | +0.512 | +0.534 | V |
| Differential Reference Temperature Coefficient | REFTC | | | ± 30 | | ppm/ $^\circ C$ |
| BUFFERED EXTERNAL REFERENCE (external $V_{REFIN} = 1.024V$ applied; V_{REFP}, V_{REFN}, V_{COM} levels are generated internally) | | | | | | |
| Reference Input Voltage | V_{REFIN} | | | 1.024 | | V |
| Differential Reference Output | V_{DIFF} | $V_{REFP} - V_{REFN}$ | | 0.512 | | V |
| Common-Mode Output Voltage | V_{COM} | | | $V_{DD}/2$ | | V |
| Maximum REFP/REFN/COM Source Current | I_{SOURCE} | | | 2 | | mA |
| Maximum REFP/REFN/COM Sink Current | I_{SINK} | | | 2 | | mA |
| REFIN Input Current | | | | -0.7 | | μA |
| REFIN Input Resistance | | | | 500 | | k Ω |
| DIGITAL INPUTS (CLK, SCLK, DIN, $\overline{CS}/WAKE$, DA9–DA0) | | | | | | |
| Input High Threshold | V_{INH} | | 0.7 x OV_{DD} | | | V |
| Input Low Threshold | V_{INL} | | 0.3 x OV_{DD} | | | V |
| Input Leakage | $D I_{IN}$ | CLK, SCLK, DIN, $\overline{CS}/WAKE = OGND$ or OV_{DD} | -1 | | +1 | μA |
| | | DA9–DA0 = OV_{DD} | -1 | | +1 | |
| | | DA9–DA0 = OGND | -5 | | +5 | |
| Input Capacitance | DC_{IN} | | | 5 | | pF |
| DIGITAL OUTPUTS (AD9–AD0, DOUT) | | | | | | |
| Output-Voltage Low | V_{OL} | $I_{SINK} = 200\mu A$ | | 0.2 x OV_{DD} | | V |
| Output-Voltage High | V_{OH} | $I_{SOURCE} = 200\mu A$ | 0.8 x OV_{DD} | | | V |
| Tri-State Leakage Current | I_{LEAK} | | -1 | | +1 | μA |
| Tri-State Output Capacitance | C_{OUT} | | | 5 | | pF |

Electrical Characteristics (continued)

($V_{DD} = 3V$, $OV_{DD} = 1.8V$, internal reference (1.024V), $C_L \approx 10pF$ on all digital outputs, $f_{CLK} = 45MHz$ (50% duty cycle), Rx ADC input amplitude = -0.5dBFS, Tx DAC output amplitude = 0dBFS, $CM1 = 0$, $CM0 = 0$, differential Rx ADC input, differential Tx DAC output, $C_{REFP} = C_{REFN} = C_{COM} = 0.33\mu F$, $C_L < 5pF$ on all aux-DAC outputs, $T_A = T_{MIN}$ to T_{MAX} , unless otherwise noted. Typical values are at $T_A = +25^\circ C$.) (Note 1)

- Note 1:** Specifications from $T_A = +25^\circ C$ to $+85^\circ C$ guaranteed by production tests. Specifications at $T_A < +25^\circ C$ guaranteed by design and characterization.
- Note 2:** The minimum clock frequency (f_{CLK}) for the MAX19713 is 7.5MHz (typ). The minimum aux-ADC sample rate clock frequency (A_{CLK}) is determined by f_{CLK} and the chosen aux-ADC clock-divider value. The minimum aux-ADC $A_{CLK} > 7.5MHz / 128 = 58.6kHz$. The aux-ADC conversion time does not include the time to clock the serial data out of DOUT. The maximum conversion time (for no averaging, $NAV G = 1$) will be $t_{CON V} (max) = (12 \times 1 \times 128) / 7.5MHz = 205\mu s$.
- Note 3:** SNR, SINAD, SFDR, HD3, and THD are based on a differential analog input voltage of -0.5dBFS referenced to the amplitude of the digital outputs. SINAD and THD are calculated using HD2 through HD6.
- Note 4:** Crosstalk rejection is measured by applying a high-frequency test tone to one channel and a low-frequency tone to the second channel. FFTs are performed on each channel. The parameter is specified as the power ratio of the first and second channel FFT test tones.
- Note 5:** Amplitude and phase matching are measured by applying the same signal to each channel, and comparing the two output signals using a sine-wave fit.
- Note 6:** Guaranteed by design and characterization.

Typical Operating Characteristics

($V_{DD} = 3V$, $OV_{DD} = 1.8V$, internal reference (1.024V), $C_L \approx 10pF$ on all digital outputs, $f_{CLK} = 45MHz$ (50% duty cycle), Rx ADC input amplitude = -0.5dBFS, Tx DAC output amplitude = 0dBFS, $CM1 = 0$, $CM0 = 0$, differential Rx ADC input, differential Tx DAC output, $C_{REFP} = C_{REFN} = C_{COM} = 0.33\mu F$, $T_A = +25^\circ C$, unless otherwise noted.)

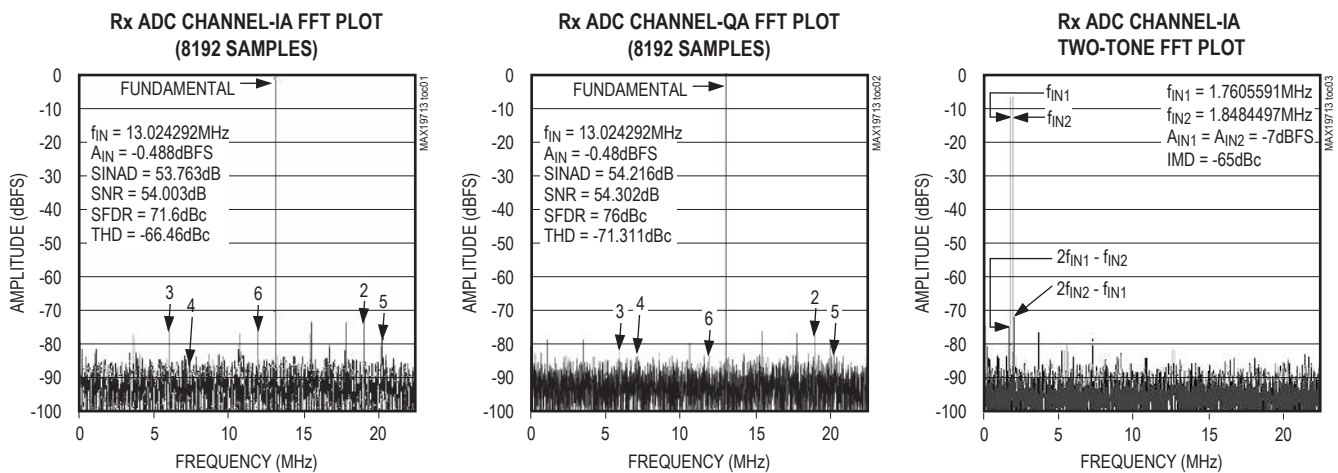

Typical Operating Characteristics (continued)

($V_{DD} = 3V$, $OV_{DD} = 1.8V$, internal reference (1.024V), $C_L \approx 10pF$ on all digital outputs, $f_{CLK} = 45MHz$ (50% duty cycle), Rx ADC input amplitude = -0.5dBFS, Tx DAC output amplitude = 0dBFS, CM1 = 0, CM0 = 0, differential Rx ADC input, differential Tx DAC output, $C_{REFP} = C_{REFN} = C_{COM} = 0.33\mu F$, $T_A = +25^\circ C$, unless otherwise noted.)

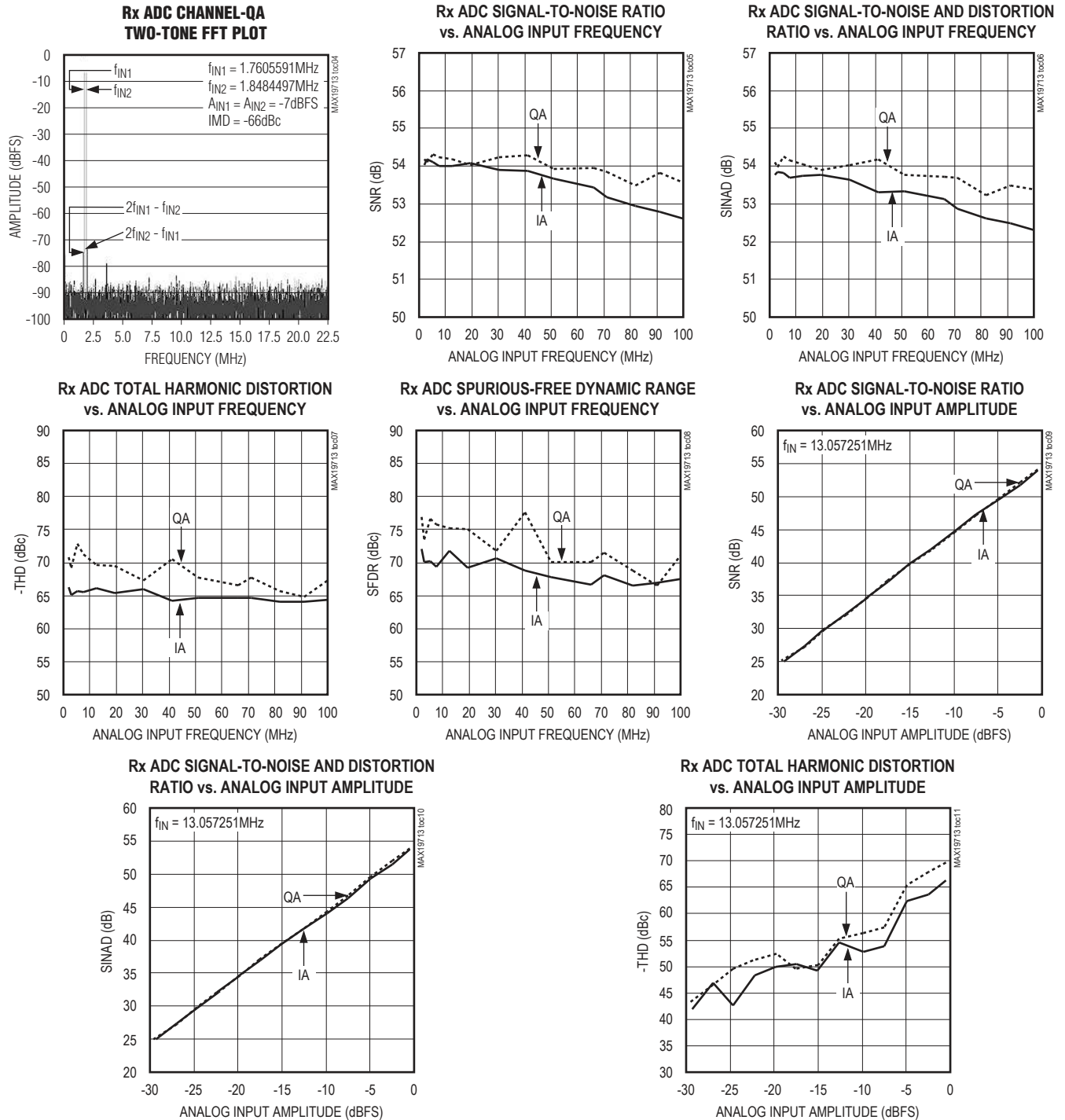

Typical Operating Characteristics (continued)

($V_{DD} = 3V$, $OV_{DD} = 1.8V$, internal reference (1.024V), $C_L \approx 10pF$ on all digital outputs, $f_{CLK} = 45MHz$ (50% duty cycle), Rx ADC input amplitude = -0.5dBFS, Tx DAC output amplitude = 0dBFS, CM1 = 0, CM0 = 0, differential Rx ADC input, differential Tx DAC output, $C_{REFP} = C_{REFN} = C_{COM} = 0.33\mu F$, $T_A = +25^\circ C$, unless otherwise noted.)

Rx ADC SPURIOUS-FREE DYNAMIC RANGE vs. ANALOG INPUT AMPLITUDE

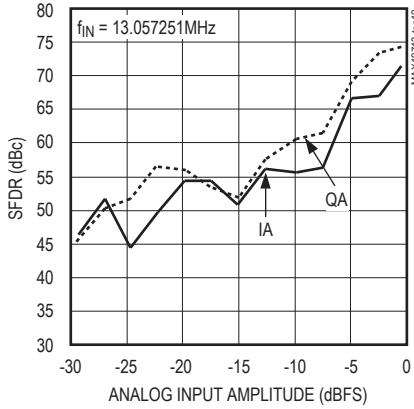

Rx ADC SIGNAL-TO-NOISE RATIO vs. SAMPLING FREQUENCY

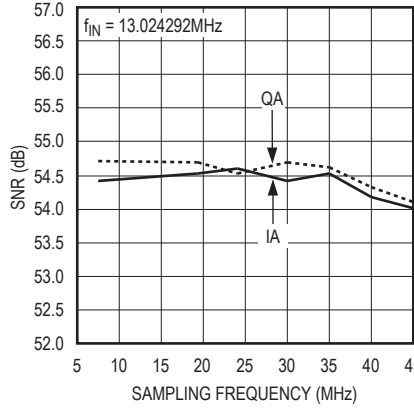

Rx ADC SIGNAL-TO-NOISE AND DISTORTION RATIO vs. SAMPLING FREQUENCY

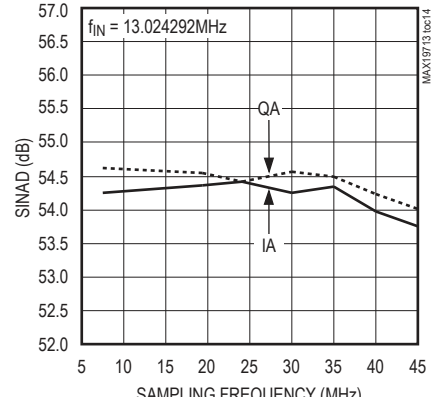

Rx ADC TOTAL HARMONIC DISTORTION vs. SAMPLING FREQUENCY

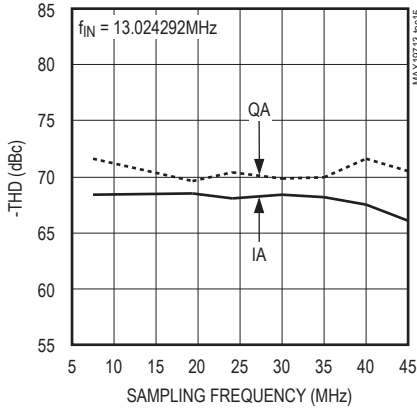

Rx ADC SPURIOUS-FREE DYNAMIC RANGE vs. SAMPLING FREQUENCY

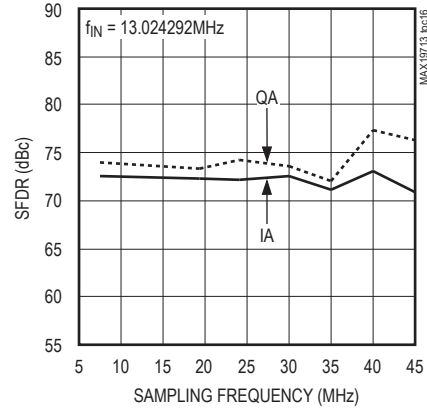

Rx ADC SIGNAL-TO-NOISE RATIO vs. CLOCK DUTY CYCLE

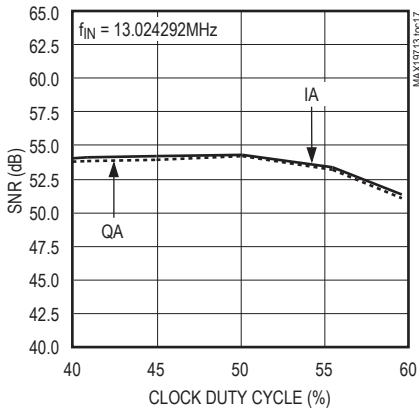

Rx ADC SIGNAL-TO-NOISE AND DISTORTION RATIO vs. CLOCK DUTY CYCLE

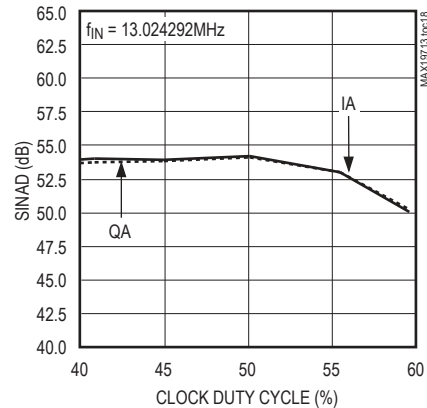

Typical Operating Characteristics (continued)

($V_{DD} = 3V$, $OV_{DD} = 1.8V$, internal reference (1.024V), $C_L \approx 10pF$ on all digital outputs, $f_{CLK} = 45MHz$ (50% duty cycle), Rx ADC input amplitude = -0.5dBFS, Tx DAC output amplitude = 0dBFS, CM1 = 0, CM0 = 0, differential Rx ADC input, differential Tx DAC output, $C_{REFP} = C_{REFN} = C_{COM} = 0.33\mu F$, $T_A = +25^\circ C$, unless otherwise noted.)

Rx ADC TOTAL HARMONIC DISTORTION vs. CLOCK DUTY CYCLE

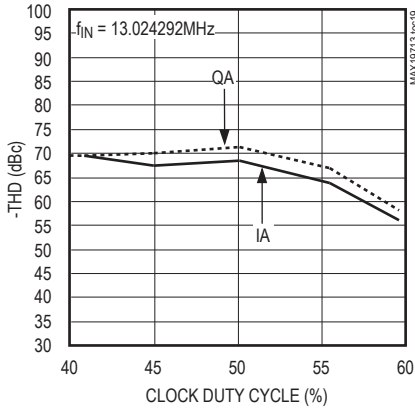

Rx ADC SPURIOUS-FREE DYNAMIC RANGE vs. CLOCK DUTY CYCLE

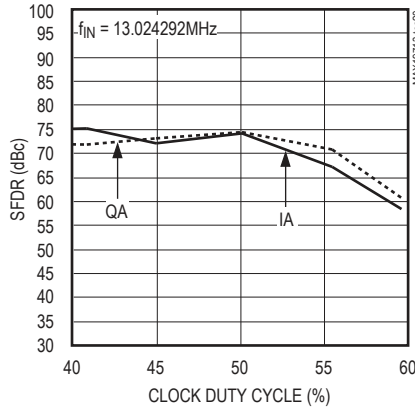

Rx ADC OFFSET ERROR vs. TEMPERATURE

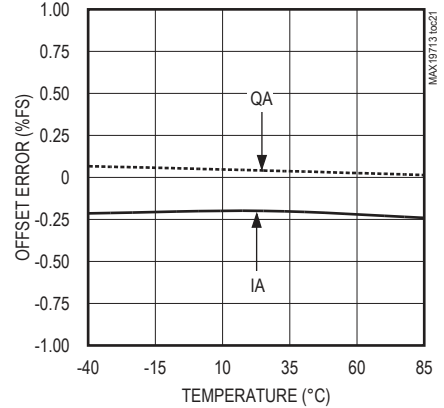

Rx ADC GAIN ERROR vs. TEMPERATURE

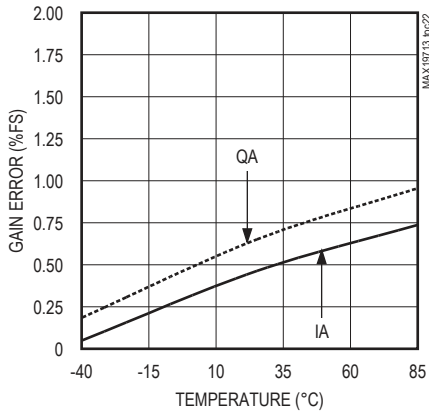

Tx DAC SPURIOUS-FREE DYNAMIC RANGE vs. SAMPLING FREQUENCY

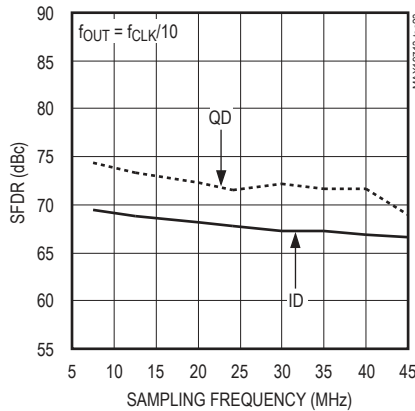

Tx DAC SPURIOUS-FREE DYNAMIC RANGE vs. OUTPUT FREQUENCY

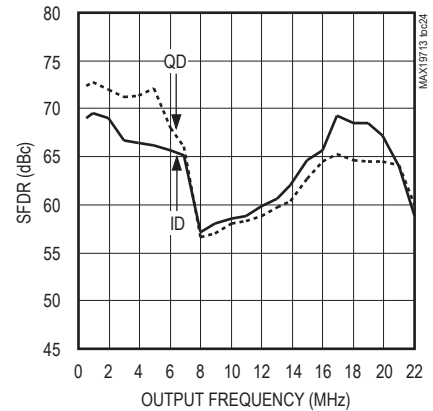

Tx DAC SPURIOUS-FREE DYNAMIC RANGE vs. OUTPUT AMPLITUDE

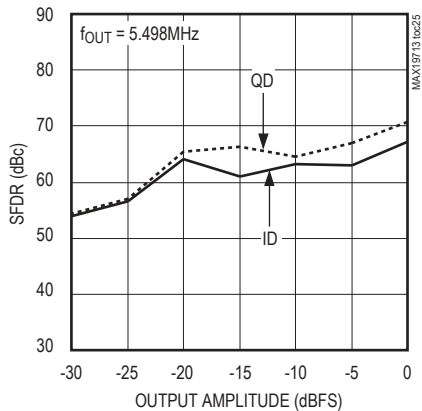

Tx DAC CHANNEL-ID SPECTRAL PLOT

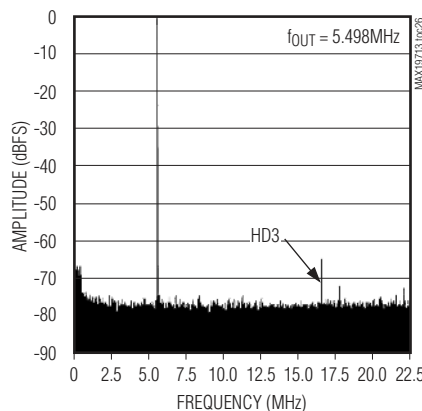

Tx DAC CHANNEL-QD SPECTRAL PLOT

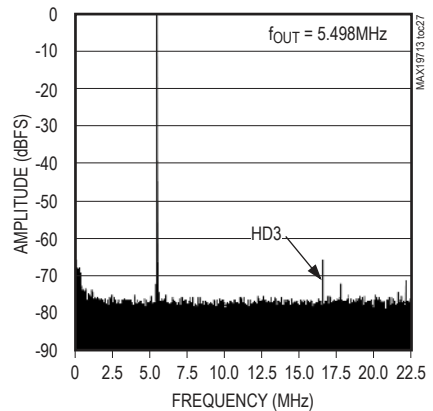

Typical Operating Characteristics (continued)

($V_{DD} = 3V$, $OV_{DD} = 1.8V$, internal reference (1.024V), $C_L \approx 10pF$ on all digital outputs, $f_{CLK} = 45MHz$ (50% duty cycle), Rx ADC input amplitude = -0.5dBFS, Tx DAC output amplitude = 0dBFS, $CM1 = 0$, $CM0 = 0$, differential Rx ADC input, differential Tx DAC output, $C_{REFP} = C_{REFN} = C_{COM} = 0.33\mu F$, $T_A = +25^\circ C$, unless otherwise noted.)

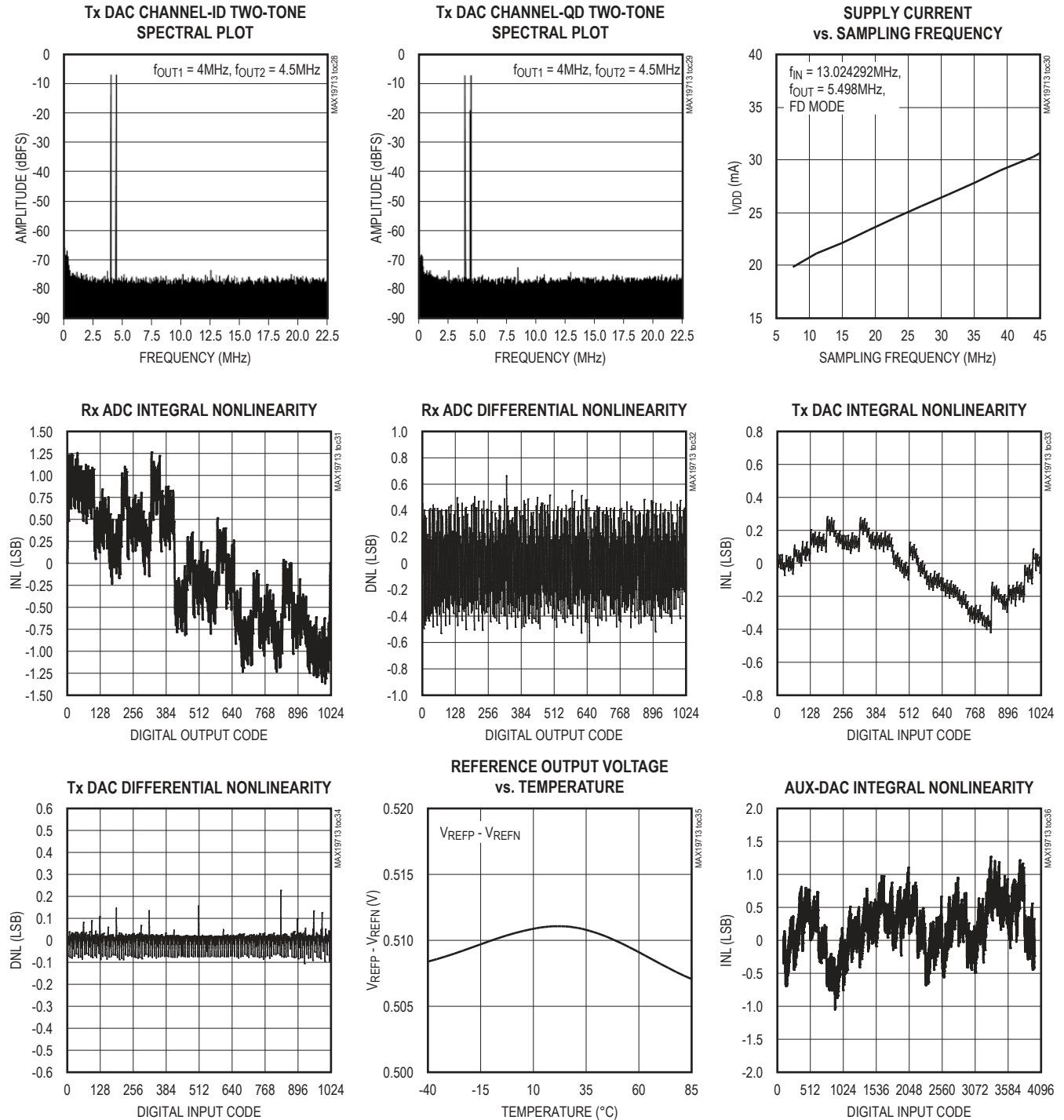

Typical Operating Characteristics (continued)

($V_{DD} = 3V$, $OV_{DD} = 1.8V$, internal reference (1.024V), $C_L \approx 10pF$ on all digital outputs, $f_{CLK} = 45MHz$ (50% duty cycle), Rx ADC input amplitude = -0.5dBFS, Tx DAC output amplitude = 0dBFS, $CM1 = 0$, $CM0 = 0$, differential Rx ADC input, differential Tx DAC output, $C_{REFP} = C_{REFN} = C_{COM} = 0.33\mu F$, $T_A = +25^\circ C$, unless otherwise noted.)

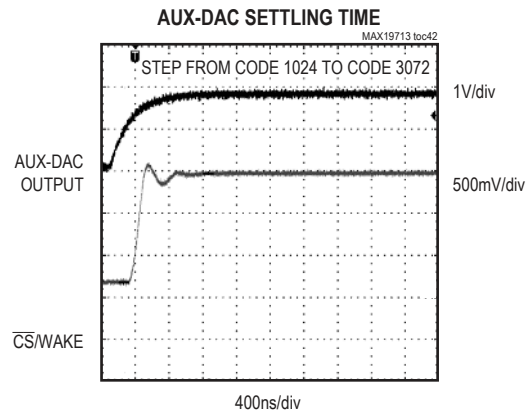
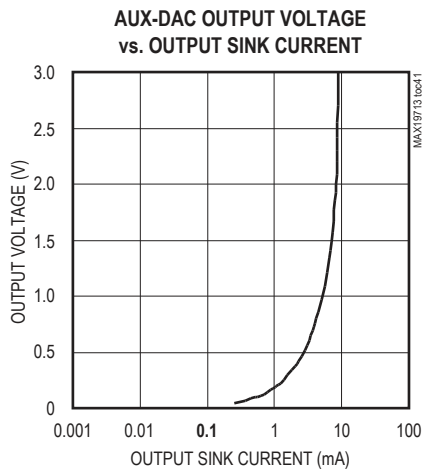
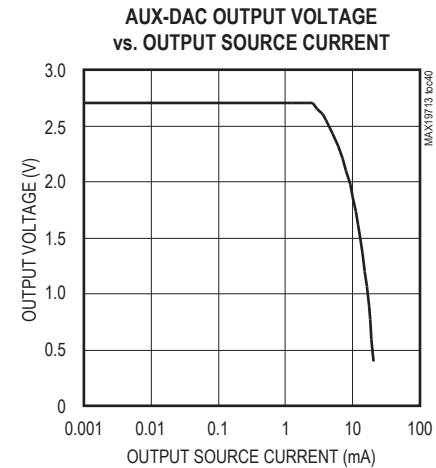
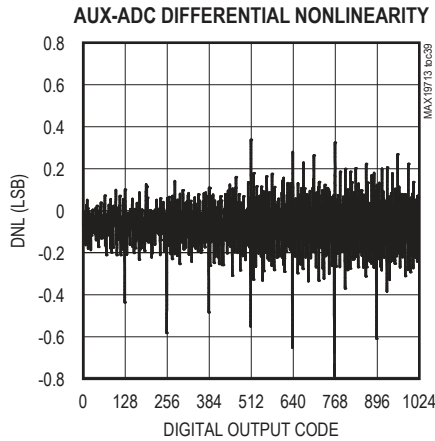
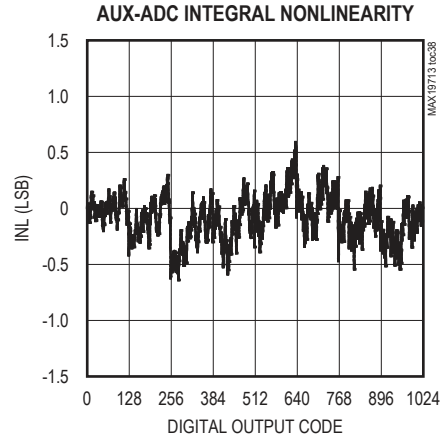
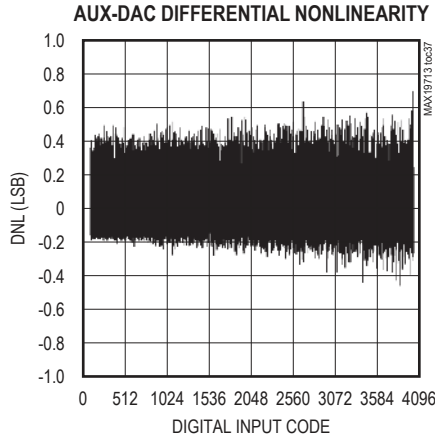

Pin Description

| PIN | NAME | FUNCTION |
|--------------------------|------------------------------|--------------------------------------------------------------------------------------------------------------------------------------------------------------------------------------------------|
| 1 | REFP | Positive Reference Voltage Input Terminal. Bypass with a 0.33 μ F capacitor to GND as close as possible to REFP. |
| 2, 8, 11, 39, 41, 47, 51 | V _{DD} | Analog Supply Voltage. Bypass V _{DD} to GND with a combination of a 2.2 μ F capacitor in parallel with a 0.1 μ F capacitor. |
| 3 | IAP | Channel-IA Positive Analog Input. For single-ended operation, connect signal source to IAP. |
| 4 | IAN | Channel-IA Negative Analog Input. For single-ended operation, connect IAN to COM. |
| 5, 7, 12, 40, 50 | GND | Analog Ground. Connect all GND pins to ground plane. |
| 6 | CLK | Conversion Clock Input. Clock signal for both receive ADCs and transmit DACs. |
| 9 | QAN | Channel-QA Negative Analog Input. For single-ended operation, connect QAN to COM. |
| 10 | QAP | Channel-QA Positive Analog Input. For single-ended operation, connect signal source to QAP. |
| 13–22 | AD0–AD9 | Receive ADC Digital Outputs. AD9 is the most significant bit (MSB) and AD0 is the least significant bit (LSB). |
| 23 | OGND | Output-Driver Ground |
| 24 | OV _{DD} | Output-Driver Power Supply. Supply range from +1.8V to V _{DD} . Bypass OV _{DD} to OGND with a combination of a 2.2 μ F capacitor in parallel with a 0.1 μ F capacitor. |
| 25–34 | DA0–DA9 | Transmit DAC Digital Inputs. DA9 is the most significant bit (MSB) and DA0 is the least significant bit (LSB). DA0–DA9 are internally pulled up to OV _{DD} . |
| 35 | DOUT | Aux-ADC Digital Output |
| 36 | DIN | 3-Wire Serial-Interface Data Input. Data is latched on the rising edge of SCLK. |
| 37 | SCLK | 3-Wire Serial-Interface Clock Input |
| 38 | $\overline{\text{CS}}$ /WAKE | 3-Wire Serial-Interface Chip-Select/WAKE Input. When the MAX19713 is in shutdown, $\overline{\text{CS}}$ /WAKE controls the wake-up function. See the <i>Wake-Up Function</i> section. |
| 42 | ADC2 | Selectable Auxiliary ADC Analog Input 2 |
| 43 | ADC1 | Selectable Auxiliary ADC Analog Input 1 |
| 44 | DAC3 | Auxiliary DAC3 Analog Output (V _{OUT} = 0 at Power-Up) |
| 45 | DAC2 | Auxiliary DAC2 Analog Output (V _{OUT} = 0 at Power-Up) |
| 46 | DAC1 | Auxiliary DAC1 Analog Output (AFC DAC, V _{OUT} = 1.1V at Power-Up) |
| 48 | IDN | Tx DAC Channel-ID Differential Negative Output |
| 49 | IDP | Tx DAC Channel-ID Differential Positive Output |
| 52 | QDN | Tx DAC Channel-QD Differential Negative Output |
| 53 | QDP | Tx DAC Channel-QD Differential Positive Output |
| 54 | REFIN | Reference Input. Connect to V _{DD} for internal reference. |
| 55 | COM | Common-Mode Voltage I/O. Bypass COM to GND with a 0.33 μ F capacitor. |
| 56 | REFN | Negative Reference Voltage Input Terminal. Rx ADC conversion range is $\pm(V_{\text{REFP}} - V_{\text{REFN}})$. Bypass REFN to GND with a 0.33 μ F capacitor. |
| — | EP | Exposed Paddle. Internally connected to GND. Connect EP to the GND plane. |

Detailed Description

The MAX19713 integrates a dual, 10-bit Rx ADC and a dual, 10-bit Tx DAC while providing ultra-low power and high dynamic performance at 45Msps conversion rate.

The Rx ADC analog input amplifiers are fully differential and accept 1.024V_{P-P} full-scale signals. The Tx DAC analog outputs are fully differential with ± 400 mV full-scale output, selectable common-mode DC level, and adjustable channel ID–QD offset trim.

The MAX19713 integrates three 12-bit auxiliary DACs (aux-DACs) and a 10-bit, 333kSPS auxiliary ADC (aux-ADC) with 4:1 input multiplexer. The aux-DAC channels feature 1µs settling time for fast AGC, VGA, and AFC level setting. The aux-ADC features data averaging to reduce processor overhead and a selectable clock-divider to program the conversion rate.

The MAX19713 includes a 3-wire serial interface to control operating modes and power management. The serial interface is SPI and MICROWIRE compatible. The MAX19713 serial interface selects shutdown, idle, standby, FD, transmit (Tx), and receive (Rx) modes, as well as controls aux-DAC and aux-ADC channels.

The MAX19713 features two independent, high-speed, 10-bit buses for the Rx ADC and Tx DAC, which allow full-duplex (FD) operation for frequency-division duplex applications. Each bus can be disabled to optimize power management through the 3-wire interface. The MAX19713

operates from a single 2.7V to 3.3V analog supply and a 1.8V to 3.3V digital supply.

Dual 10-Bit Rx ADC

The ADC uses a seven-stage, fully differential, pipelined architecture that allows for high-speed conversion while minimizing power consumption. Samples taken at the inputs move progressively through the pipeline stages every half clock cycle. Including the delay through the output latch, the total clock-cycle latency is 5 clock cycles for channel IA and 5.5 clock cycles for channel QA. The ADC full-scale analog input range is ±VREF with a VDD/2 (±0.8V) common-mode input range. VREF is the difference between VREFP and VREFN. See the [Reference Configurations](#) section for details.

Input Track-and-Hold (T/H) Circuits

Figure 1 displays a simplified diagram of the Rx ADC input track-and-hold (T/H) circuitry. Both ADC inputs (IAP, QAP, IAN, and QAN) can be driven either differentially or single-ended. Match the impedance of IAP and IAN, as

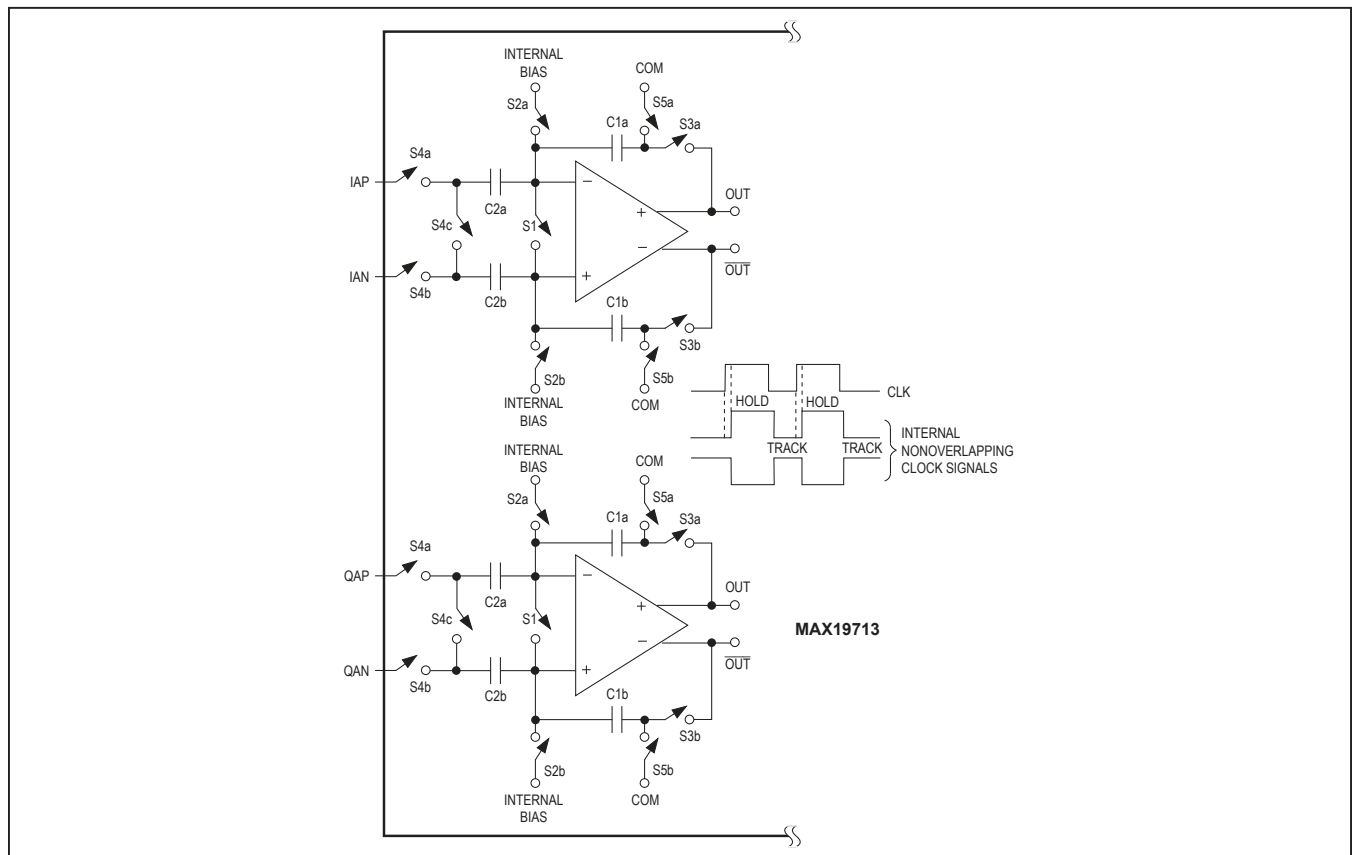

Figure 1. Rx ADC Internal T/H Circuits

Table 1. Rx ADC Output Codes vs. Input Voltage

| DIFFERENTIAL INPUT VOLTAGE | DIFFERENTIAL INPUT (LSB) | OFFSET BINARY (AD0–AD9) | OUTPUT DECIMAL CODE |
|----------------------------|----------------------------|-------------------------|---------------------|
| $V_{REF} \times 512/512$ | 511 (+Full Scale - 1 LSB) | 11 1111 1111 | 1023 |
| $V_{REF} \times 511/512$ | 510 (+Full Scale - 2 LSB) | 11 1111 1110 | 1022 |
| $V_{REF} \times 1/512$ | +1 | 10 0000 0001 | 513 |
| $V_{REF} \times 0/512$ | 0 (Bipolar Zero) | 10 0000 0000 | 512 |
| $-V_{REF} \times 1/512$ | -1 | 01 1111 1111 | 511 |
| $-V_{REF} \times 511/512$ | -511 (-Full Scale + 1 LSB) | 00 0000 0001 | 1 |
| $-V_{REF} \times 512/512$ | -512 (-Full Scale) | 00 0000 0000 | 0 |

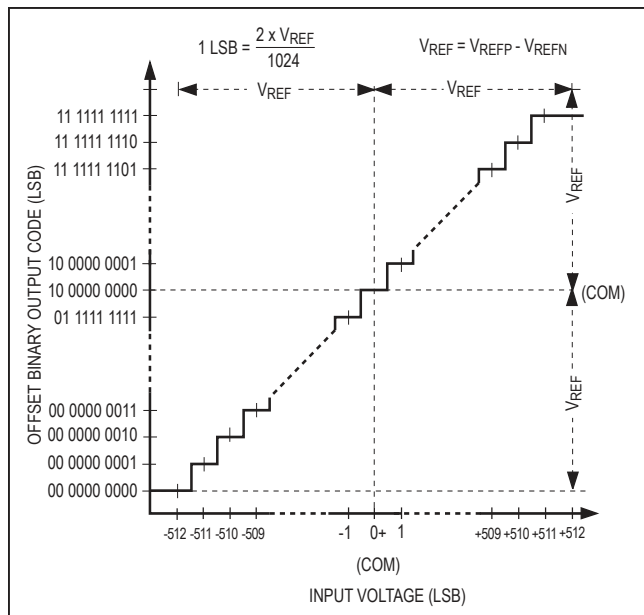

Figure 2. Rx ADC Transfer Function

well as QAP and QAN, and set the input signal common-mode voltage within the $V_{DD}/2$ ($\pm 0.8V$) Rx ADC range for optimum performance.

Rx ADC System Timing Requirements

Figure 3 shows the relationship between the clock, analog inputs, and the resulting output data. Channels IA and QA are sampled on the rising edge of the clock signal (CLK) and the resulting data is multiplexed at the AD0–AD9 outputs. Channel IA data is updated on the rising edge and channel QA data is updated on the falling edge of

CLK. Including the delay through the output latch, the total clock-cycle latency is 5 clock cycles for channel IA and 5.5 clock cycles for channel QA.

Digital Output Data (AD0–AD9)

AD0–AD9 are the Rx ADC digital logic outputs of the MAX19713. The logic level is set by OV_{DD} from 1.8V to V_{DD} . The digital output coding is offset binary (Table 1). Keep the capacitive load on the digital outputs AD0–AD9 as low as possible ($< 15pF$) to avoid large digital currents feeding back into the analog portion of the MAX19713 and degrading its dynamic performance. Buffers on the digital outputs isolate the outputs from heavy capacitive loads. Adding 100Ω resistors in series with the digital outputs close to the MAX19713 will help improve ADC performance. Refer to the MAX19713 EV kit schematic for an example of the digital outputs driving a digital buffer through 100Ω series resistors.

During SHDN, IDLE, STBY, SPI2, and SPI4 states, digital outputs AD0–AD9 are three-stated.

Dual 10-Bit Tx DACs

The dual 10-bit digital-to-analog converters (Tx DACs) operate with clock speeds up to 45MHz. The Tx DAC digital inputs, DA0–DA9, are multiplexed on a single 10-bit transmit bus. The voltage reference determines the Tx DAC full-scale voltage at IDP, IDN and QDP, QDN analog outputs. See the [Reference Configurations](#) section for setting the reference voltage.

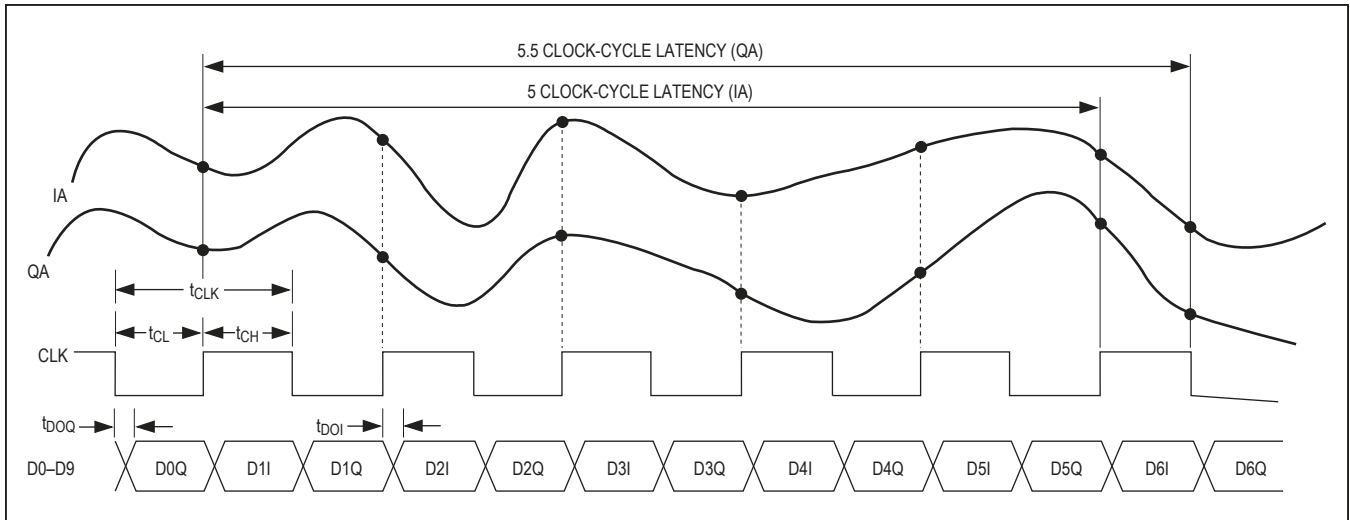

Figure 3. Rx ADC System Timing Diagram

Table 2. Tx DAC Output Voltage vs. Input Codes

(Internal Reference Mode V_{REFDAC} = 1.024V, External Reference Mode V_{REFDAC} = V_{REFIN}, V_{FS} = 400 for 800mV_{P-P} Full Scale)

| DIFFERENTIAL OUTPUT VOLTAGE (V) | OFFSET BINARY (DA0-DA9) | INPUT DECIMAL CODE |
|--------------------------------------------------------------|-------------------------|--------------------|
| $(V_{FS}) \frac{V_{REFDAC}}{1024} \times \frac{1023}{1023}$ | 11 1111 1111 | 1023 |
| $(V_{FS}) \frac{V_{REFDAC}}{1024} \times \frac{1021}{1023}$ | 11 1111 1110 | 1022 |
| $(V_{FS}) \frac{V_{REFDAC}}{1024} \times \frac{3}{1023}$ | 10 0000 0001 | 513 |
| $(V_{FS}) \frac{V_{REFDAC}}{1024} \times \frac{1}{1023}$ | 10 0000 0000 | 512 |
| $(V_{FS}) \frac{-V_{REFDAC}}{1024} \times \frac{1}{1023}$ | 01 1111 1111 | 511 |
| $(V_{FS}) \frac{-V_{REFDAC}}{1024} \times \frac{1021}{1023}$ | 00 0000 0001 | 1 |
| $(V_{FS}) \frac{-V_{REFDAC}}{1024} \times \frac{1023}{1023}$ | 00 0000 0000 | 0 |

The Tx DAC outputs (IDN, IDP, QDN, QDP) are biased at an adjustable common-mode DC level and designed to drive a differential input stage with ≥ 70kΩ input impedance. This simplifies the analog interface between RF quadrature upconverters and the MAX19713. Many RF upconverters require a 0.71V to 1.06V common-mode bias. The MAX19713 common-mode DC bias eliminates discrete level-setting resistors and code-generated level shifting while preserving the full dynamic range of each Tx DAC. **The Tx DAC differential analog outputs cannot be used in single-ended mode because of the**

internally generated common-mode DC level. Table 2 shows the Tx DAC output voltage vs. input codes. Table 10 shows the selection of DC common-mode levels.

See Table 4 for an illustration of the Tx DAC analog output levels. The Tx DAC also features an independent DC offset trim on each ID-QD channel. This feature is configured through the SPI interface. The DC offset correction is used to optimize sideband and carrier suppression in the Tx signal path (see Table 9).

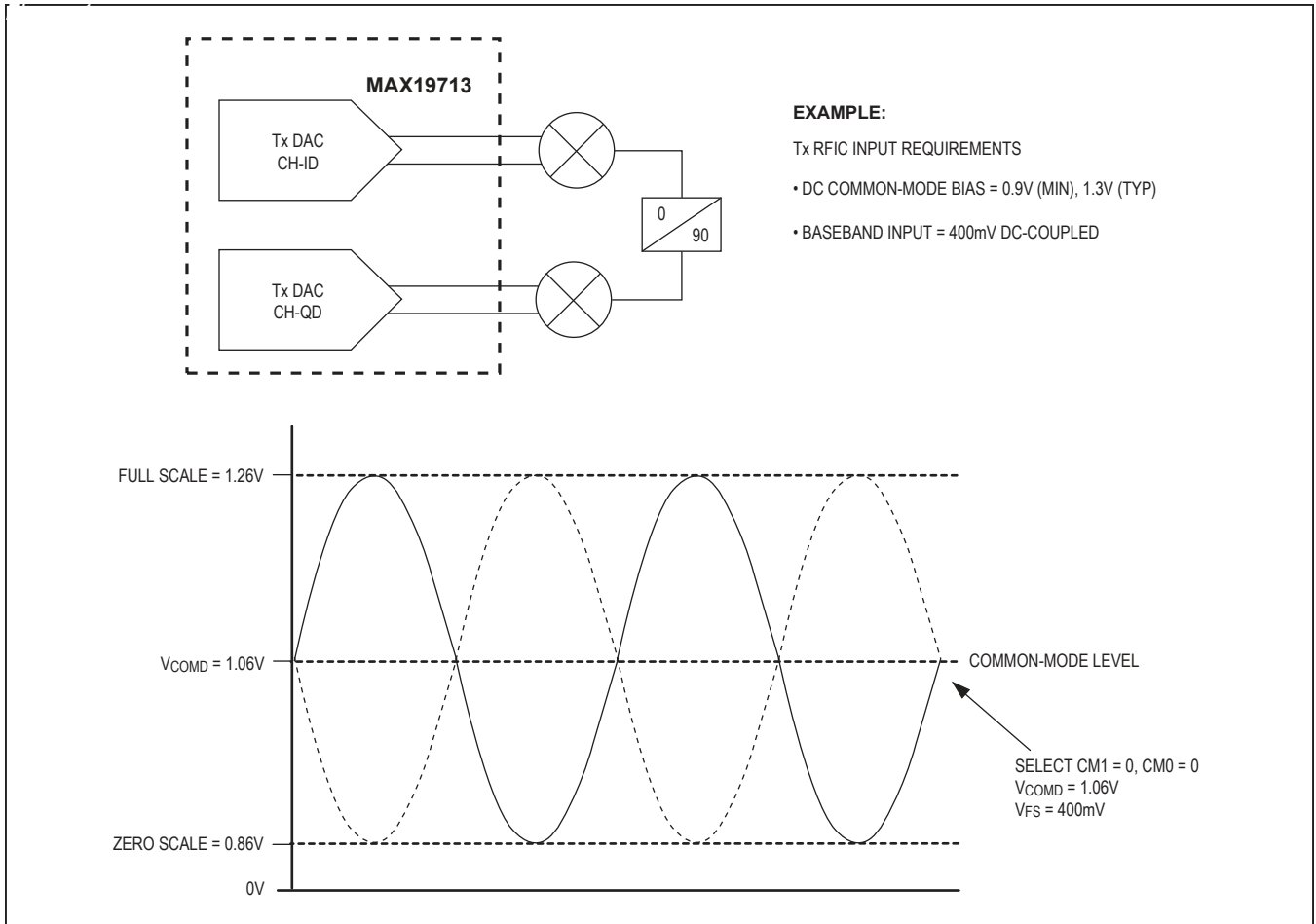

Figure 4. Tx DAC Common-Mode DC Level at IDN, IDP or QDN, QDP Differential Outputs

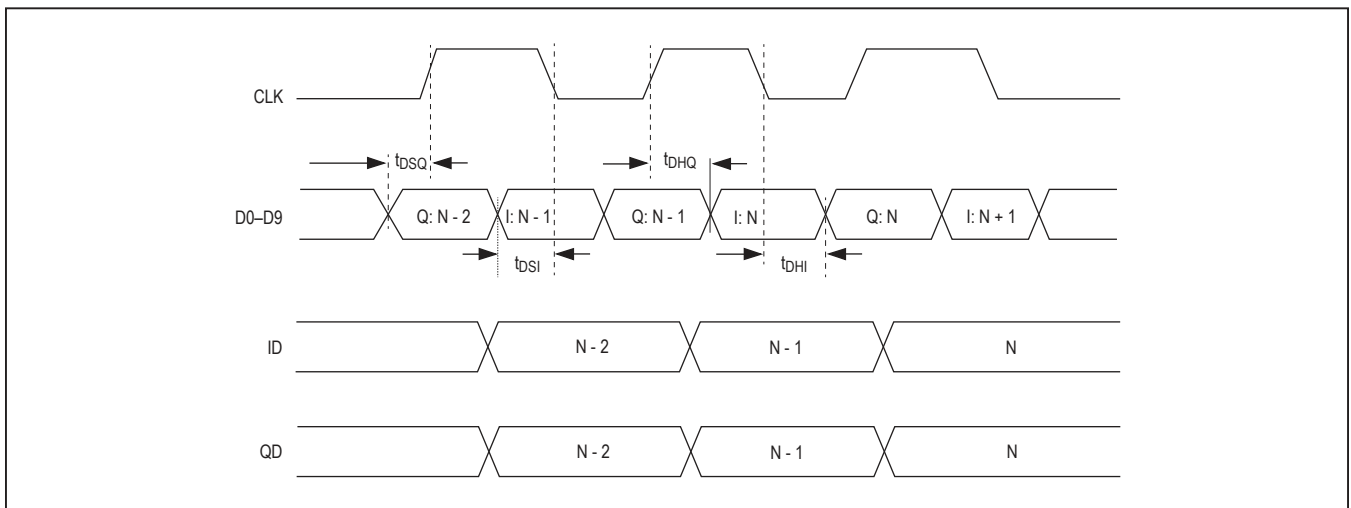

Figure 5. Tx DAC System Timing Diagram

Tx DAC Timing

[Figure 5](#) shows the relationship among the clock, input data, and analog outputs. Channel ID data is latched on the falling edge of the clock signal, and channel QD data is latched on the rising edge of the clock signal, at which point both ID and QD outputs are simultaneously updated.

3-Wire Serial Interface and Operation Modes

The 3-wire serial interface controls the MAX19713 operation modes as well as the three 12-bit aux-DACs and the 10-bit aux-ADC. Upon power-up, program the MAX19713 to operate in the desired mode. Use the 3-wire serial interface to program the device for shutdown, idle, standby, FD, Rx, Tx, aux-DAC controls, or aux-ADC conversion. A 16-bit data register sets the mode control as shown in [Table 3](#). The 16-bit word is composed of four control bits (A3–A0) and 12 data bits (D11–D0). Data is shifted in MSB first (D11) and LSB last (A0) format. [Table 4](#) shows the MAX19713 power-management modes. [Table 5](#) shows the SPI-controlled Tx, Rx, and FD modes. The serial interface remains active in all modes.

SPI Register Description

Program the control bits, A3–A0, in the register as shown in [Table 3](#) to select the operating mode. Modify A3–A0 bits to select from ENABLE-16, Aux-DAC1, Aux-DAC2, Aux-DAC3, IOFFSET, QOFFSET, COMSEL, Aux-ADC, ENABLE-8, and WAKEUP-SEL modes. ENABLE-16 is the default operating mode ([Table 6](#)). This mode allows for shutdown, idle, and standby states as well as switching between FAST, SLOW, Rx and Tx modes. [Table 4](#) and [Table 5](#) show the required SPI settings for each mode.

In ENABLE-16 mode, the aux-DACs have independent control bits E4, E5, and E6, bit E9 enables the aux-ADC. [Table 7](#) shows the auxiliary DAC enable codes. [Table 8](#) shows the auxiliary ADC enable code. Bits E11 and E10 are reserved. Program bits E11 and E10 to logic-low. Bits E3, E7, and E8 are not used.

Modes aux-DAC1, aux-DAC2, and aux-DAC3 select the aux-DAC channels named DAC1, DAC2, and DAC3 and hold the data inputs for each DAC. Bits $_D11\text{--}_D0$ are the data inputs for each aux-DAC and can be programmed through SPI. The MAX19713 also includes two 6-bit registers that can be programmed to adjust the offsets for the Tx DAC ID and QD channels independently (see [Table 9](#)). Use the COMSEL mode to select the output common-mode voltage with bits CM1 and CM0 ([Table 10](#)). Use aux-ADC mode to start the auxiliary ADC conversion (see the [10-Bit, 333ksps Auxiliary ADC](#) section for details). Use ENABLE-8 mode for faster enable and switching

between shutdown, idle, and standby states as well as switching between FAST, SLOW, Rx and Tx modes and the FD mode.

The WAKEUP-SEL register selects the operating mode that the MAX19713 is to enter immediately after coming out of shutdown ([Table 11](#)). See the [Wake-Up Function](#) section for more information.

Shutdown mode offers the most dramatic power savings by shutting down all the analog sections (including the reference) of the MAX19713. In shutdown mode, the Rx ADC digital outputs are in three-state mode, the Tx DAC digital inputs are internally pulled to OV_{DD} , and the Tx DAC outputs are at 0V. When the Rx ADC outputs transition from three-state to active mode, the last converted word is placed on the digital output bus. The Tx DAC previously stored data is lost when coming out of shutdown mode. The wake-up time from shutdown mode is dominated by the time required to charge the capacitors at REFP, REFN, and COM. In internal reference mode and buffered external reference mode, the wake-up time is typically 500 μ s to enter Rx mode, 26.4 μ s to enter Tx mode, and 500 μ s to enter FD mode.

In all operating modes, the Tx DAC inputs DA0–DA9 are internally pulled to OV_{DD} . To reduce the supply current of the MAX19713 in shutdown mode do not pull DA0–DA9 low. This consideration is especially important in shutdown mode to achieve the lowest quiescent current.

In idle mode, the reference and clock distribution circuits are powered, but all other functions are off. The Rx ADC outputs AD0–AD9 are forced to three-state. The Tx DAC DA0–DA9 inputs are internally pulled to OV_{DD} , while the Tx DAC outputs are at 0V. The wake-up time is 3.7 μ s to enter Rx mode, 5.1 μ s to enter Tx mode, and 5.1 μ s to enter FD mode. When the Rx ADC outputs transition from three-state to active, the last converted word is placed on the digital output bus.

In standby mode, the reference is powered but all other device functions are off. The wake-up time from standby mode is 3.8 μ s to enter Rx mode, 24.4 μ s to enter Tx mode, and 24.4 μ s to enter FD mode. When the Rx ADC outputs transition from three-state to active, the last converted word is placed on the digital output bus.

FAST and SLOW Rx and Tx Modes

The MAX19713 features FAST and SLOW modes for switching between Rx and Tx operation. In FAST Tx mode, the Rx ADC core is powered on but the ADC digital outputs AD0–AD9 are three-stated. The Tx DAC digital bus is active and the DAC core is fully operational.

Table 3. MAX19713 Mode Control

| REGISTER NAME | D11 | D10 | D9 | D8 | D7 | D6 | D5 | D4 | D3 | D2 | D1 | D0 | A3 | A2 | A1 | A0 |
|---------------|----------------------|---------------------|-----|-----|-----|-----|-----|-----|-----|-----|-----|-----|----|----|----|---------|
| | (MSB) | 15 | 14 | 13 | 12 | 11 | 10 | 9 | 8 | 7 | 6 | 5 | 4 | 3 | 2 | 1 (LSB) |
| ENABLE-16 | E11 = 0 Reserved | E10 = 0 Reserved | E9 | — | — | E6 | E5 | E4 | — | E2 | E1 | E0 | 0 | 0 | 0 | 0 |
| Aux-DAC1 | 1D11 | 1D10 | 1D9 | 1D8 | 1D7 | 1D6 | 1D5 | 1D4 | 1D3 | 1D2 | 1D1 | 1D0 | 0 | 0 | 0 | 1 |
| Aux-DAC2 | 2D11 | 2D10 | 2D9 | 2D8 | 2D7 | 2D6 | 2D5 | 2D4 | 2D3 | 2D2 | 2D1 | 2D0 | 0 | 0 | 1 | 0 |
| Aux-DAC3 | 3D11 | 3D10 | 3D9 | 3D8 | 3D7 | 3D6 | 3D5 | 3D4 | 3D3 | 3D2 | 3D1 | 3D0 | 0 | 0 | 1 | 1 |
| IOFFSET | — | — | — | — | — | — | IO5 | IO4 | IO3 | IO2 | IO1 | IO0 | 0 | 1 | 0 | 0 |
| QOFFSET | — | — | — | — | — | — | QO5 | QO4 | QO3 | QO2 | QO1 | QO0 | 0 | 1 | 0 | 1 |
| COMSEL | — | — | — | — | — | — | — | — | — | — | CM1 | CM0 | 0 | 1 | 1 | 0 |
| Aux-ADC | AD11 = 0 Reserved | AD10 | AD9 | AD8 | AD7 | AD6 | AD5 | AD4 | AD3 | AD2 | AD1 | AD0 | 0 | 1 | 1 | 1 |
| ENABLE-8 | — | — | — | — | — | — | — | — | — | E2 | E1 | E0 | 1 | 0 | 0 | 0 |
| WAKEUP-SEL | — | — | — | — | — | — | — | — | — | W2 | W1 | W0 | 1 | 0 | 0 | 1 |

— = Not used.

Table 4. Power-Management Modes

| ADDRESS | | | | DATA BITS | | | | MODE | FUNCTION (POWER MANAGEMENT) | DESCRIPTION | COMMENT |
|-----------------------------------------------------|----|----|----|-----------|----|----|----|------|-----------------------------|--------------------------------------------------------------------------------------------------------------------|--------------------------------------------|
| A3 | A2 | A1 | A0 | E9* | E2 | E1 | E0 | | | | |
| 0000 (16-Bit Mode) or 1000 (8-Bit Mode) | | | | 1 | 0 | 0 | 0 | SHDN | SHUTDOWN | Rx ADC = OFF Tx DAC = OFF (TX DAC outputs at 0V) Aux-DAC = OFF Aux-ADC = OFF CLK = OFF REF = OFF | Device is in complete shutdown. |
| | | | | X** | 0 | 0 | 1 | IDLE | IDLE | Rx ADC = OFF Tx DAC = OFF (TX DAC outputs at 0V) Aux-DAC = Last State CLK = ON REF = ON | Fast turn-on time. Moderate idle power. |
| | | | | X** | 0 | 1 | 0 | STBY | STANDBY | Rx ADC = OFF Tx DAC = OFF (TX DAC outputs at 0V) Aux-DAC = Last State CLK = OFF REF = ON | Slow turn-on time. Low standby power. |

X = Don't care.

*Bit E9 is not available in 8-bit mode.

**In IDLE and STBY modes, the aux-ADC can be turned on or off.

Table 5. MAX19713 Tx, Rx, and FD Control Using SPI Commands

| ADDRESS | | | | DATA BITS | | | MODE | FUNCTION (Tx-Rx SWITCHING SPEED) | DESCRIPTION | COMMENT |
|------------------------------------------------------|----|----|----|-----------|----|----|---------|-------------------------------------|------------------------------------------------------------------------------------------------------------------------------------------------------|---------------------------------------------------------------------------|
| A3 | A2 | A1 | A0 | E2 | E1 | E0 | | | | |
| 0000 (16-Bit Mode) and 1000 (8-Bit Mode) | | | | 0 | 1 | 1 | SPI1-Rx | SLOW | Rx Mode: Rx ADC = ON Rx Bus = Enabled Tx DAC = OFF (Tx DAC outputs at 0V) Tx Bus = OFF (all inputs are pulled high) | Slow transition to Tx mode from this mode. Low power. |
| | | | | 1 | 0 | 0 | SPI2-Tx | SLOW | Tx Mode: Rx ADC = OFF Rx Bus = Tri-state Tx DAC = ON Tx Bus = ON | Slow transition to Rx mode from this mode. Low power. |
| | | | | 1 | 0 | 1 | SPI3-Rx | FAST | Rx Mode: Rx ADC = ON Rx Bus = Enabled Tx DAC = ON (Tx DAC outputs at midscale) Tx Bus = OFF (all inputs are pulled high) | Fast transition to Tx mode from this mode. Moderate power. |
| | | | | 1 | 1 | 0 | SPI4-Tx | FAST | Tx Mode: Rx ADC = ON Rx Bus = Tri-state Tx DAC = ON Tx Bus = ON | Fast transition to Rx mode from this mode. Moderate power. |
| | | | | 1 | 1 | 1 | FD | FAST | FD Mode: Rx ADC = ON Rx Bus = ON Tx DAC = ON Tx Bus = ON | Default Mode Fast transition to any mode. Moderate power. |

In FAST Rx mode, the Tx DAC core is powered on. The Tx DAC outputs are set to midscale. In this mode, the Tx DAC input bus is disconnected from the DAC core and DA0–DA9 are internally pulled to OV_{DD} . The Rx ADC digital bus is active and the ADC core is fully operational.

In FAST mode, the switching time from Tx to Rx, or Rx to Tx is minimized because the converters are on and do not have to recover from a power-down state. In FAST mode, the switching time from Rx to Tx and Tx to Rx is 0.1 μ s. Power consumption is higher in FAST mode because both Tx and Rx cores are always on.

In SLOW Tx mode, the Rx ADC core is powered off and the ADC digital outputs AD0–AD9 are three-stated. The

Tx DAC digital bus is active and the DAC core is fully operational. In SLOW Rx mode, the Tx DAC core is powered off. The Tx DAC outputs are set to 0. In SLOW Rx mode, the Tx DAC input bus is disconnected from the DAC core and DA0–DA9 are internally pulled to OV_{DD} . The Rx ADC digital bus is active and the ADC core is fully operational. The switching times for SLOW modes are 4.9 μ s for Rx to Tx and 3.7 μ s for Tx to Rx.

Power consumption in SLOW Tx mode is 49.5mW, and 79.2mW in SLOW Rx mode. Power consumption in FAST Tx mode is 89.1mW, and 86.4mW in FAST Rx mode.

Table 6. MAX19713 Default (Power-On) Register Settings

| REGISTER NAME | D11 | D10 | D9 | D8 | D7 | D6 | D5 | D4 | D3 | D2 | D1 | D0 |
|---------------|-------------------------|----------------------------------------------------------------------------------------------------------------------|--------------|----|----|---------------------------|-------------------------|----|----|---------|----|---------------------------|
| | 16 (MSB) | 15 | 14 | 13 | 12 | 11 | 10 | 9 | 8 | 7 | 6 | 5 |
| ENABLE-16 | 0 | 0 | 0 | — | — | 0 | 0 | 0 | — | 1 | 1 | 1 |
| | | | Aux-ADC = ON | | | Aux-DAC1 to Aux-DAC3 = ON | | | | FD mode | | |
| Aux-DAC1 | 0 | 1 | 1 | 0 | 1 | 0 | 0 | 0 | 1 | 1 | 0 | 0 |
| | DAC1 output set to 1.1V | | | | | | | | | | | |
| Aux-DAC2 | 0 | 0 | 0 | 0 | 0 | 0 | 0 | 0 | 0 | 0 | 0 | 0 |
| | DAC2 output set to 0V | | | | | | | | | | | |
| Aux-DAC3 | 0 | 0 | 0 | 0 | 0 | 0 | 0 | 0 | 0 | 0 | 0 | 0 |
| | DAC3 output set to 0V | | | | | | | | | | | |
| IOFFSET | — | — | — | — | — | — | 0 | 0 | 0 | 0 | 0 | 0 |
| | | | | | | | No offset on channel ID | | | | | |
| QOFFSET | — | — | — | — | — | — | 0 | 0 | 0 | 0 | 0 | 0 |
| | | | | | | | No offset on channel QD | | | | | |
| COMSEL | — | — | — | — | — | — | — | — | — | — | 0 | 0 |
| | | | | | | | | | | | | V _{COMD} = 1.06V |
| Aux-ADC | 0 | 0 | 0 | 0 | 0 | 0 | 0 | 0 | 0 | 0 | 0 | 0 |
| | | Aux-ADC = ON, Conversion = IDLE, Aux-ADC REF = 2.048V, MUX = ADC1, Averaging = 1, Clock Divider = 1, DOUT = Disabled | | | | | | | | | | |
| ENABLE-8 | — | — | — | — | — | — | — | — | — | 1 | 1 | 1 |
| | | | | | | | | | | | | FD mode |
| WAKEUP-SEL | — | — | — | — | — | — | — | — | — | 1 | 1 | 1 |
| | | | | | | | | | | | | Wake-up state = FD mode |

Table 7. Aux-DAC Enable Table (ENABLE-16 Mode)

| E6 | E5 | E4 | Aux-DAC3 | Aux-DAC2 | Aux-DAC1 |
|----------|----------|----------|---------------------|----------|----------|
| 0 | 0 | 0 | ON | ON | ON |
| 0 | 0 | 1 | ON | ON | OFF |
| 0 | 1 | 0 | ON | OFF | ON |
| 0 | 1 | 1 | ON | OFF | OFF |
| 1 | 0 | 0 | OFF | ON | ON |
| 1 | 0 | 1 | OFF | ON | OFF |
| 1 | 1 | 0 | OFF | OFF | ON |
| 1 | 1 | 1 | OFF | OFF | OFF |
| 0 | 0 | 0 | Default mode | | |

Table 8. Aux-ADC Enable Table (ENABLE-16 Mode)

| E9 | SELECTION |
|-------------|------------------------|
| 0 (Default) | Aux-ADC is Powered ON |
| 1 | Aux-ADC is Powered OFF |

FD Mode

The MAX19713 features an FD mode, which is ideal for applications supporting frequency-division duplex. In FD mode, both Rx ADC and Tx DAC, as well as their respective digital buses, are active and the device can receive and transmit simultaneously. Switching from FD mode to other Rx or Tx modes is fast (0.1µs) since the on-board

Table 9. Offset Control Bits for ID and QD Channels (IOFFSET or QOFFSET Mode)

| BITS IO5–IO0 WHEN IN IOFFSET MODE, BITS QO5–QO0 WHEN IN QOFFSET MODE | | | | | | OFFSET 1 LSB = (VFS _{p-p} /1023) |
|----------------------------------------------------------------------|---------|---------|---------|---------|---------|----------------------------------------------|
| IO5/QO5 | IO4/QO4 | IO3/QO3 | IO2/QO2 | IO1/QO1 | IO0/QO0 | |
| 1 | 1 | 1 | 1 | 1 | 1 | -31 LSB |
| 1 | 1 | 1 | 1 | 1 | 0 | -30 LSB |
| 1 | 1 | 1 | 1 | 0 | 1 | -29 LSB |
| • | • | • | • | • | • | • |
| • | • | • | • | • | • | • |
| • | • | • | • | • | • | • |
| 1 | 0 | 0 | 0 | 1 | 0 | -2 LSB |
| 1 | 0 | 0 | 0 | 0 | 1 | -1 LSB |
| 1 | 0 | 0 | 0 | 0 | 0 | 0mV |
| 0 | 0 | 0 | 0 | 0 | 0 | 0mV (Default) |
| 0 | 0 | 0 | 0 | 0 | 1 | 1 LSB |
| 0 | 0 | 0 | 0 | 1 | 0 | 2 LSB |
| • | • | • | • | • | • | • |
| • | • | • | • | • | • | • |
| • | • | • | • | • | • | • |
| 0 | 1 | 1 | 1 | 0 | 1 | 29 LSB |
| 0 | 1 | 1 | 1 | 1 | 0 | 30 LSB |
| 0 | 1 | 1 | 1 | 1 | 1 | 31 LSB |

Note: 1 LSB = (800mV_{p-p}/1023) = 0.782mV.

Table 10. Common-Mode Select (COMSEL Mode)

| CM1 | CM0 | Tx PATH OUTPUT COMMON MODE (V) |
|-----|-----|--------------------------------|
| 0 | 0 | 1.06 (Default) |
| 0 | 1 | 0.94 |
| 1 | 0 | 0.82 |
| 1 | 1 | 0.71 |

converters are already powered. Consequently, power consumption in this mode is the maximum of all operating modes. In FD mode the MAX19713 consumes 91.8mW.

Wake-Up Function

The MAX19713 uses the SPI interface to control the operating modes of the device including the shutdown and wake-up functions. Once the device has been placed in shutdown through the appropriate SPI command, the first pulse on $\overline{CS}/WAKE$ performs a wake-up function. At the first rising edge of $\overline{CS}/WAKE$, the MAX19713 is forced to a preset operating mode determined by the WAKEUP-SEL register. This mode is termed the wake-up state. If

Table 11. WAKEUP-SEL Register

| W2 | W1 | W0 | POWER MODE AFTER WAKE-UP (WAKE-UP STATE) |
|----|----|----|----------------------------------------------------------------------------------------------------|
| 0 | 0 | 0 | Invalid Value. This value is ignored when inadvertently written to the WAKEUP-SEL register. |
| 0 | 0 | 1 | IDLE |
| 0 | 1 | 0 | STBY |
| 0 | 1 | 1 | SPI1-SLOW Rx |
| 1 | 0 | 0 | SPI2-SLOW Tx |
| 1 | 0 | 1 | SPI3-FAST Rx |
| 1 | 1 | 0 | SPI4-FAST Tx |
| 1 | 1 | 1 | FD (Default) |

the WAKEUP-SEL register has not been programmed, the wake-up state for the MAX19713 is FD mode by default (Table 6, Table 11). The WAKEUP-SEL register cannot be programmed with W2 = 0, W1 = 0, and W0 = 0. If this value is inadvertently written to the device, it is ignored and the register continues to store its previous

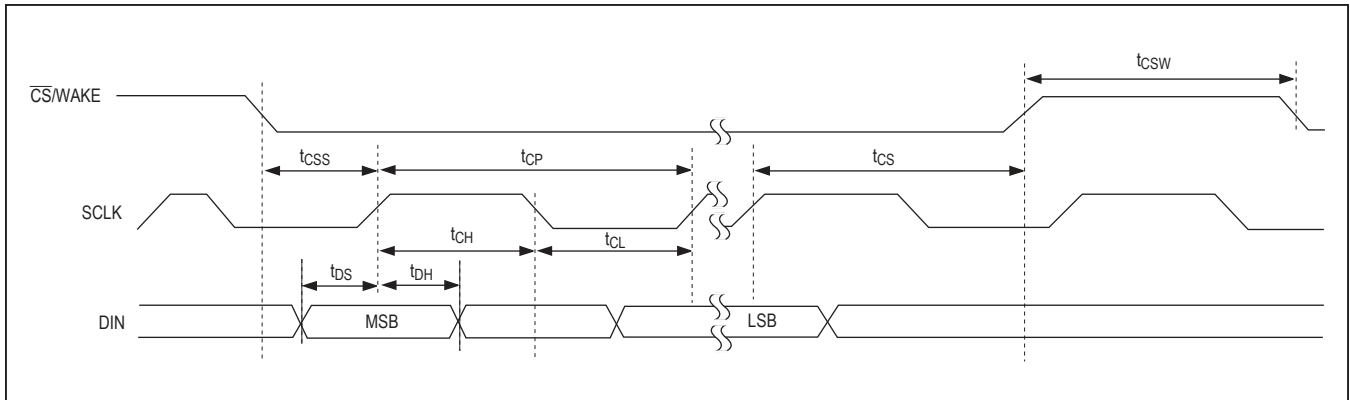

Figure 6. Serial-Interface Timing Diagram

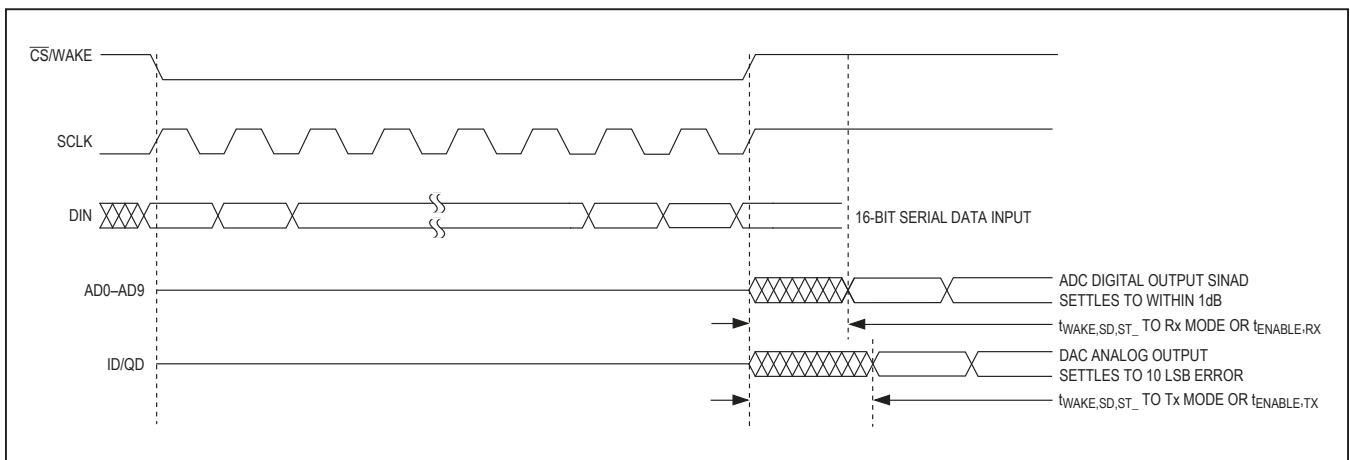

Figure 7. Mode-Recovery Timing Diagram

value. Upon wake-up, the MAX19713 enters the power mode determined by the WAKEUP-SEL register, however, all other settings (Tx DAC offset, Tx DAC common-mode voltage, aux-DAC settings, aux-ADC state) are restored to their values prior to shutdown.

The only SPI line that is monitored by the MAX19713 during shutdown is $\overline{CS}/WAKE$. Any information transmitted to the MAX19713 concurrent with the $\overline{CS}/WAKE$ wake-up pulse is ignored.

SPI Timing

The serial digital interface is a standard 3-wire connection ($\overline{CS}/WAKE$, SCLK, DIN) compatible with SPI/QSPI™/MICROWIRE/DSP interfaces. Set $\overline{CS}/WAKE$ low to enable the serial data loading at DIN or output at DOUT. Following a $\overline{CS}/WAKE$ high-to-low transition, data is shifted synchronously, most significant bit first, on the rising edge of the serial clock (SCLK). After 16 bits are loaded into the serial input register, data is transferred

to the latch when $\overline{CS}/WAKE$ transitions high. $\overline{CS}/WAKE$ must transition high for a minimum of 80ns before the next write sequence. SCLK can idle either high or low between transitions. Figure 6 shows the detailed timing diagram of the 3-wire serial interface.

Mode-Recovery Timing

Figure 7 shows the mode-recovery timing diagram. t_{WAKE} is the wake-up time when exiting shutdown, idle, or standby mode and entering Rx, Tx, or FD mode. t_{ENABLE} is the recovery time when switching between either Rx or Tx mode. t_{WAKE} or t_{ENABLE} is the time for the Rx ADC to settle within 1dB of specified SINAD performance and Tx DAC settling to 10 LSB error. t_{WAKE} and t_{ENABLE} times are measured after the 16-bit serial command is latched into the MAX19713 by a $\overline{CS}/WAKE$ transition high. In FAST mode, the recovery time is 0.1µs to switch between Tx or Rx modes.

QSPI is a trademark of Motorola, Inc.

System Clock Input (CLK)

Both the Rx ADC and Tx DAC share the CLK input. The CLK input accepts a CMOS-compatible signal level set by OV_{DD} from 1.8V to V_{DD} . Since the interstage conversion of the device depends on the repeatability of the rising and falling edges of the external clock, use a clock with low jitter and fast rise and fall times ($< 2\text{ns}$). Specifically, sampling occurs on the rising edge of the clock signal, requiring this edge to provide the lowest possible jitter. Any significant clock jitter limits the SNR performance of the on-chip Rx ADC as follows:

$$\text{SNR} = 20 \times \log \left(\frac{1}{2 \times \pi \times f_{IN} \times t_{AJ}} \right)$$

where f_{IN} represents the analog input frequency and t_{AJ} is the time of the clock jitter.

Clock jitter is especially critical for undersampling applications. Consider the clock input as an analog input and route away from any analog input or other digital signal lines. The MAX19713 clock input operates with an $OV_{DD}/2$ voltage threshold and accepts a 50% $\pm 10\%$ duty cycle.

When the clock signal is stopped at CLK input (CLK = 0 or OV_{DD}), all internal registers hold their last value and the MAX19713 saves the last power-management mode or Tx/Rx/FD command. All converter circuits (Rx ADC, Tx DAC, aux-ADC, and aux-DACs) hold their last value. When the clock signal is restarted at CLK, allow 3.8 μs (clock wake-up time) for the internal clock circuitry to settle before updating the Tx DAC, reading a valid Rx ADC conversion result, or starting an aux-ADC conversion. This ensures the converters (Rx ADC, Tx DAC, aux-ADC) meet all dynamic performance specifications. The aux-DAC channels are not dependent on CLK, so they can be updated when CLK is idle.

12-Bit, Auxiliary Control DACs

The MAX19713 includes three 12-bit aux-DACs (DAC1, DAC2, DAC3) with 1 μs settling time for controlling variable-gain amplifier (VGA), automatic gain-control (AGC), and automatic frequency-control (AFC) functions. The aux-DAC output range is 0.2V to 2.57V as defined by $V_{OH} - V_{OL}$. During power-up, the VGA and AGC outputs (DAC2 and DAC3) are at zero. The AFC DAC (DAC1) is at 1.1V during power-up. The aux-DACs can be independently controlled through the SPI bus, except during SHDN mode where the aux-DACs are turned off completely and the output voltage is set to zero. In STBY and IDLE modes the aux-DACs maintain the last value. On wake-up from SHDN, the aux-DACs resume the last values.

Loading on the aux-DAC outputs should be carefully observed to achieve the specified settling time and stability. The capacitive load must be kept to a maximum of 5pF including package and trace capacitance. The resistive load must be greater than 200k Ω . If capacitive loading exceeds 5pF, then add a 10k Ω resistor in series with the output. Adding the series resistor helps drive larger load capacitance ($< 15\text{pF}$) at the expense of slower settling time.

10-Bit, 333ksps Auxiliary ADC

The MAX19713 integrates a 333ksps, 10-bit aux-ADC with an input 4:1 multiplexer. In the aux-ADC mode register, setting bit AD0 begins a conversion with the auxiliary ADC. Bit AD0 automatically clears when the conversion is complete. Setting or clearing AD0 during a conversion has no effect (Table 12). Bit AD1 determines the internal reference of the auxiliary ADC (Table 13). Bits AD2 and AD3 determine the auxiliary ADC input source (Table 14). Bits AD4, AD5, and AD6 select the number of averages taken when a single start-convert command is given. The conversion time increases as the number of averages increases (Table 15). The conversion clock can be divided down from the system clock by properly setting bits AD7, AD8, and AD9 (Table 16). The aux-ADC output data can be written out of DOUT by setting bit AD10 high (Table 17).

The aux-ADC features a 4:1 input multiplexer to allow measurements on four input sources. The input sources are selected by AD3 and AD2 (Table 14). Two of the multiplexer inputs (ADC1 and ADC2) can be connected to external sources such as an RF power detector like the MAX2208 or temperature sensor like the MAX6613. The other two multiplexer inputs are internal connections to V_{DD} and OV_{DD} that monitor the powersupply voltages. The internal V_{DD} and OV_{DD} connections are made through integrated dividers that yield $V_{DD}/2$ and $OV_{DD}/2$ measurement results. The aux-ADC voltage reference can be selected between an internal 2.048V bandgap reference or V_{DD} (Table 13). The V_{DD} reference selection is provided to allow measurement of an external voltage source with a full-scale range extending beyond the 2.048V level. The input source voltage range cannot extend above V_{DD} .

The conversion requires 12 clock edges (1 for input sampling, 1 for each of the 10 bits, and 1 at the end for loading into the serial output register) to complete one conversion cycle (when no averaging is being done). Each conversion of an average (when averaging is set greater than 1) requires 12 clock edges. The conversion clock is generated from the system clock input (CLK). An SPI-programmable divider divides the system clock by the appropriate divisor (set with bits AD7, AD8, and

Table 12. Auxiliary ADC Convert

| AD0 | SELECTION |
|-----|------------------------|
| 0 | Aux-ADC Idle (Default) |
| 1 | Aux-ADC Start-Convert |

Table 13. Auxiliary ADC Reference

| AD1 | SELECTION |
|-----|-------------------------------------|
| 0 | Internal 2.048V Reference (Default) |
| 1 | Internal V_{DD} Reference |

Table 14. Auxiliary ADC Input Source

| AD3 | AD2 | Aux-ADC INPUT SOURCE |
|-----|-----|----------------------|
| 0 | 0 | ADC1 (Default) |
| 0 | 1 | ADC2 |
| 1 | 0 | $V_{DD}/2$ |
| 1 | 1 | $OV_{DD}/2$ |

Table 15. Auxiliary ADC Averaging

| AD6 | AD5 | AD4 | Aux-ADC AVERAGING |
|-----|-----|-----|---------------------------------------|
| 0 | 0 | 0 | 1 Conversion (No Averaging) (Default) |
| 0 | 0 | 1 | Average of 2 Conversions |
| 0 | 1 | 0 | Average of 4 Conversions |
| 0 | 1 | 1 | Average of 8 Conversions |
| 1 | 0 | 0 | Average of 16 Conversions |
| 1 | 0 | 1 | Average of 32 Conversions |
| 1 | 1 | X | Average of 32 Conversions |

X = Don't care.

AD9; [Table 16](#)) and provides the conversion clock to the auxiliary ADC. The auxiliary ADC has a maximum conversion rate of 333ksps. The maximum conversion clock frequency is 4MHz (333ksps x 12 clocks). Choose the proper divider value to keep the conversion clock frequency under 4MHz, based upon the system CLK frequency supplied to the MAX19713 ([Table 16](#)). The total conversion time (t_{CONV}) of the auxiliary ADC can be calculated as $t_{CONV} = (12 \times N_{AVG} \times N_{DIV})/f_{CLK}$; where N_{AVG} is the number of averages ([Table 15](#)), N_{DIV} is the CLK divisor ([Table 16](#)), and f_{CLK} is the system CLK frequency.

Table 16. Auxiliary ADC Clock (CLK) Divider

| AD9 | AD8 | AD7 | Aux-ADC CONVERSION CLOCK |
|-----|-----|-----|----------------------------|
| 0 | 0 | 0 | CLK Divided by 1 (Default) |
| 0 | 0 | 1 | CLK Divided by 2 |
| 0 | 1 | 0 | CLK Divided by 4 |
| 0 | 1 | 1 | CLK Divided by 8 |
| 1 | 0 | 0 | CLK Divided by 16 |
| 1 | 0 | 1 | CLK Divided by 32 |
| 1 | 1 | 0 | CLK Divided by 64 |
| 1 | 1 | 1 | CLK Divided by 128 |

Table 17. Auxiliary ADC Data Output Mode

| AD10 | SELECTION |
|------|-----------------------------------------------------------------|
| 0 | Aux-ADC Data is Not Available on DOUT (Default) |
| 1 | Aux-ADC Enters Data Output Mode Where Data is Available on DOUT |

Reading DOUT from the Aux-ADC

DOUT is normally in a high-impedance condition. Upon setting the auxiliary ADC start conversion bit (bit AD0), DOUT becomes active and goes high, indicating that the aux-ADC is busy. When the conversion cycle is complete (including averaging), the data is placed into an output register and DOUT goes low, indicating that the output data is ready to be driven onto DOUT. When bit AD10 is set (AD10 = 1), the aux-ADC enters a data output mode where data is available at DOUT on the next low assertion of $\overline{CS}/WAKE$. The auxiliary ADC data is shifted out of DOUT (MSB first) with the data transitioning on the falling edge of the serial clock (SCLK). Since a DOUT read requires 16 bits, DOUT holds the value of the last conversion data bit for the last 6 bits (6 least significant bits) following the aux-ADC conversion data. DOUT enters a high-impedance state when $\overline{CS}/WAKE$ is deasserted high. When bit AD10 is cleared (AD10 = 0), the aux-ADC data is not available on DOUT ([Table 17](#)).

After the aux-ADC completes a conversion, the data result is loaded to an output register waiting to be shifted out. No further conversions are possible until data is shifted out. This means that if the first conversion command sets AD10 = 0, AD0 = 1, then it cannot be followed by conversion commands setting AD10 = 0, AD0 = 1 or AD10 = 1, AD0 = 1. If this sequence of commands is inadvertently used then DOUT is disabled. To resume normal operation set AD0 = 0.

The fastest method to perform sequential conversions with the aux-ADC is by sending consecutive commands setting AD10 = 1, AD0 = 1. With this sequence the CS/WAKE falling edge shifts data from the previous conversion on to DOUT and the rising edge of CS/WAKE loads

the next conversion command at DIN. Allow enough time for each conversion to complete before sending the next conversion command. See Figure 8 for single and continuous conversion examples.

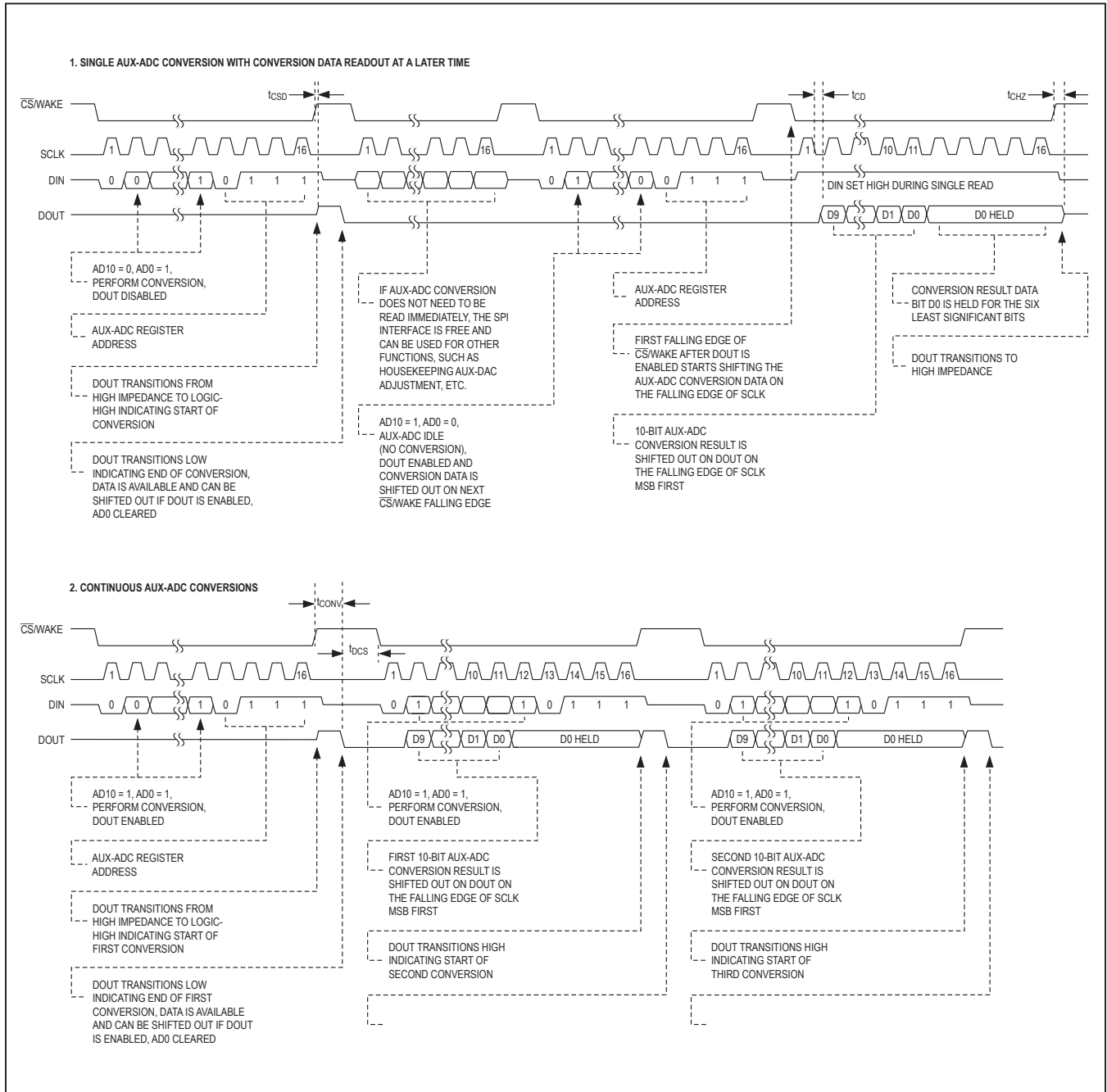

Figure 8. Aux-ADC Conversions Timing

DIN can be written independent of DOUT state. A 16-bit instruction at DIN updates the device configuration. To prevent modifying internal registers while reading data from DOUT, hold DIN at a high state (only applies if sequential aux-ADC conversions are not executed). This effectively writes all ones into address 1111. Since address 1111 does not exist, no internal registers are affected.

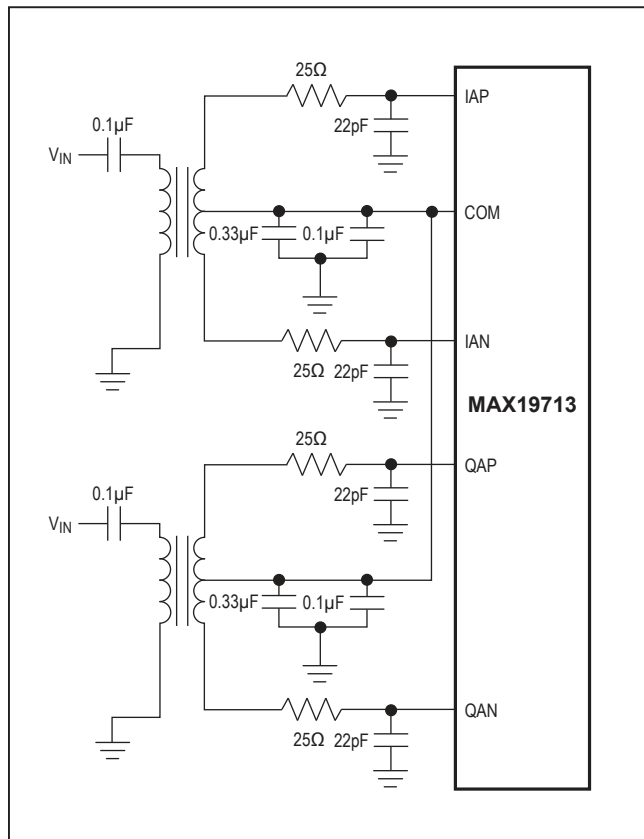

Figure 9. Balun Transformer-Coupled Single-Ended-to-Differential Input Drive for Rx ADC

Reference Configurations

The MAX19713 features an internal precision 1.024V-bandgap reference that is stable over the entire power-supply and temperature ranges. The REFIN input provides two modes of reference operation. The voltage at REFIN (V_{REFIN}) sets the reference operation mode (Table 18).

In internal reference mode, connect REFIN to V_{DD} . V_{REF} is an internally generated 0.512V $\pm 4\%$ reference level. COM, REFP, and REFN are low-impedance outputs with $V_{COM} = V_{DD}/2$, $V_{REFP} = V_{DD}/2 + V_{REF}/2$, and $V_{REFN} = V_{DD}/2 - V_{REF}/2$. Bypass REFP, REFN, and COM each with a 0.33µF capacitor. Bypass REFIN to GND with a 0.1µF capacitor.

In buffered external reference mode, apply 1.024V $\pm 10\%$ at REFIN. In this mode, COM, REFP, and REFN are low-impedance outputs with $V_{COM} = V_{DD}/2$, $V_{REFP} = V_{DD}/2 + V_{REFIN}/4$, and $V_{REFN} = V_{DD}/2 - V_{REFIN}/4$. Bypass REFP, REFN, and COM each with a 0.33µF capacitor. Bypass REFIN to GND with a 0.1µF capacitor. In this mode, the Tx DAC full-scale output is proportional to the external reference. For example, if the V_{REFIN} is increased by 10% (max), the Tx DAC full-scale output is also increased by 10% or $\pm 440mV$.

Applications Information

Using Balun Transformer AC-Coupling

An RF transformer (Figure 9) provides an excellent solution to convert a single-ended signal source to a fully differential signal for optimum ADC performance. Connecting the center tap of the transformer to COM provides a $V_{DD}/2$ DC level shift to the input. A 1:1 transformer can be used, or a step-up transformer can be selected to reduce the drive requirements. In general, the MAX19713 provides better SFDR and THD with fully differential input signals than single-ended signals, especially for high input frequencies. In differential mode, even-order harmonics are lower as both inputs (IAP, IAN, QAP, QAN) are balanced, and each of the Rx ADC inputs

Table 18. Reference Modes

| V_{REFIN} | REFERENCE MODE |
|------------------------|---------------------------------------------------------------------------------------------------------------------------------------------------------------------------------------------------------------------------------------------------------------------|
| $> 0.8V \times V_{DD}$ | Internal Reference Mode. V_{REF} is internally generated to be 0.512V. Bypass REFP, REFN, and COM each with a 0.33µF capacitor. |
| 1.024V $\pm 10\%$ | Buffered External Reference Mode. An external 1.024V $\pm 10\%$ reference voltage is applied to REFIN. V_{REF} is internally generated to be $V_{REFIN}/2$. Bypass REFP, REFN, and COM each with a 0.33µF capacitor. Bypass REFIN to GND with a 0.1µF capacitor. |

only requires half the signal swing compared to single-ended mode. Figure 10 shows an RF transformer converting the MAX19713 Tx DAC differential analog outputs to single-ended.

Using Op-Amp Coupling

Drive the MAX19713 Rx ADC with op amps when a balun transformer is not available. Figure 11 and Figure 12 show the Rx ADC being driven by op amps for AC-coupled single-ended and DC-coupled differential applications. Amplifiers such as the MAX4454 and MAX4354 provide high speed, high bandwidth, low noise, and low distortion to maintain the input signal integrity. The op-amp circuit shown in Figure 12 can also be used to interface with the Tx DAC differential analog outputs to provide gain or buffering. The Tx DAC differential analog outputs cannot be used in single-ended mode because of the internally generated common-mode level. Also, the Tx DAC analog outputs are designed to drive a differential input stage with input impedance $\geq 70k\Omega$. If single-ended outputs are desired, use an amplifier to provide differential-to-single-ended conversion and select an amplifier with proper input common-mode voltage range.

FDD Application

Figure 13 illustrates a typical FDD application circuit. The MAX19713 interfaces directly with the radio front-ends to provide a complete “RF-to-Bits” solution for FDD applications such as 802.11, 802.16, WCDMA, and proprietary radio systems. The MAX19713 provides several system benefits to digital baseband developers:

- Fast Time-to-Market
- High-Performance, Low-Power Analog Functions
- Low-Risk, Proven Analog Front-End Solution
- No Mixed-Signal Test Times
- No NRE Charges
- No IP Royalty Charges
- Enables Digital Baseband and Scale with 65nm to 90nm CMOS

Grounding, Bypassing, and Board Layout

The MAX19713 requires high-speed board layout design techniques. Refer to the MAX19713 EV kit data sheet for a board layout reference. Place all bypass capacitors as close to the device as possible, preferably on the same side of the board as the device, using surface-mount devices for minimum inductance. Bypass V_{DD} to GND with a $0.1\mu F$ ceramic capacitor in parallel with a $2.2\mu F$ capacitor. Bypass OV_{DD} to OGND with a $0.1\mu F$ ceramic

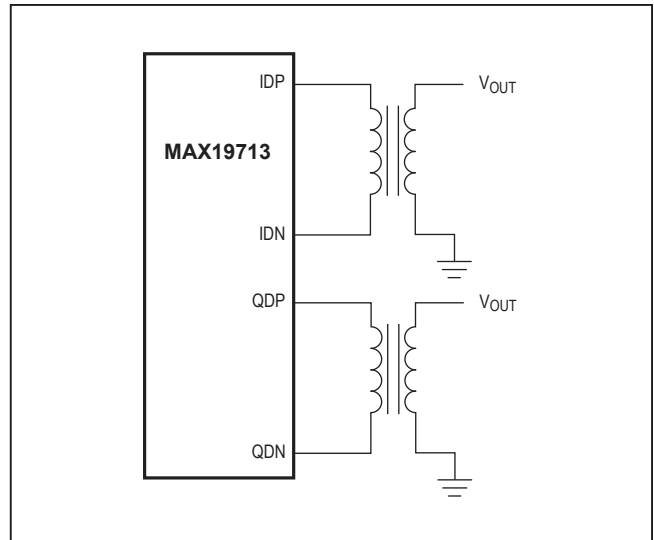

Figure 10. Balun Transformer-Coupled Differential-to-Single-Ended Output Drive for Tx DAC

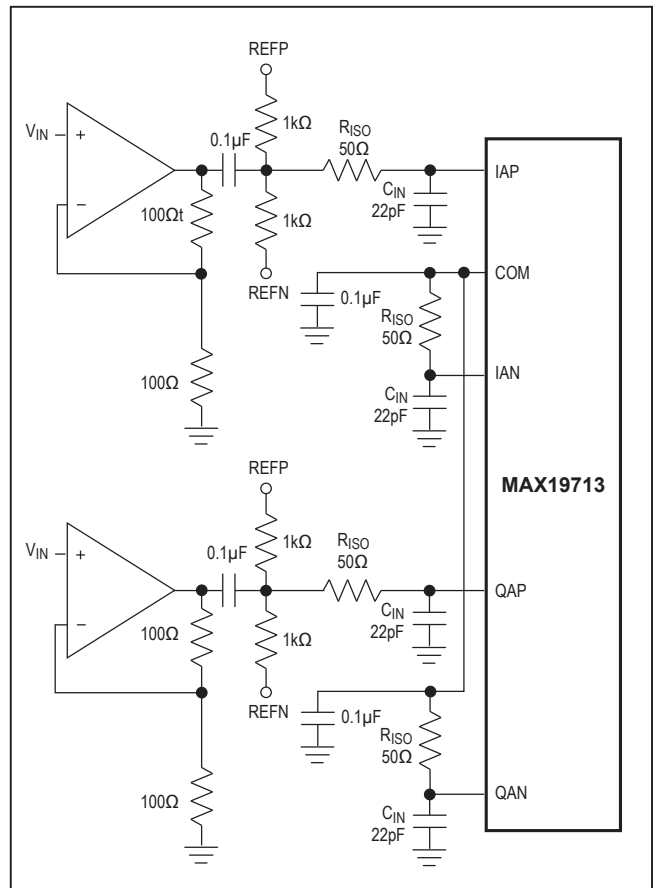

Figure 11. Single-Ended Drive for Rx ADC

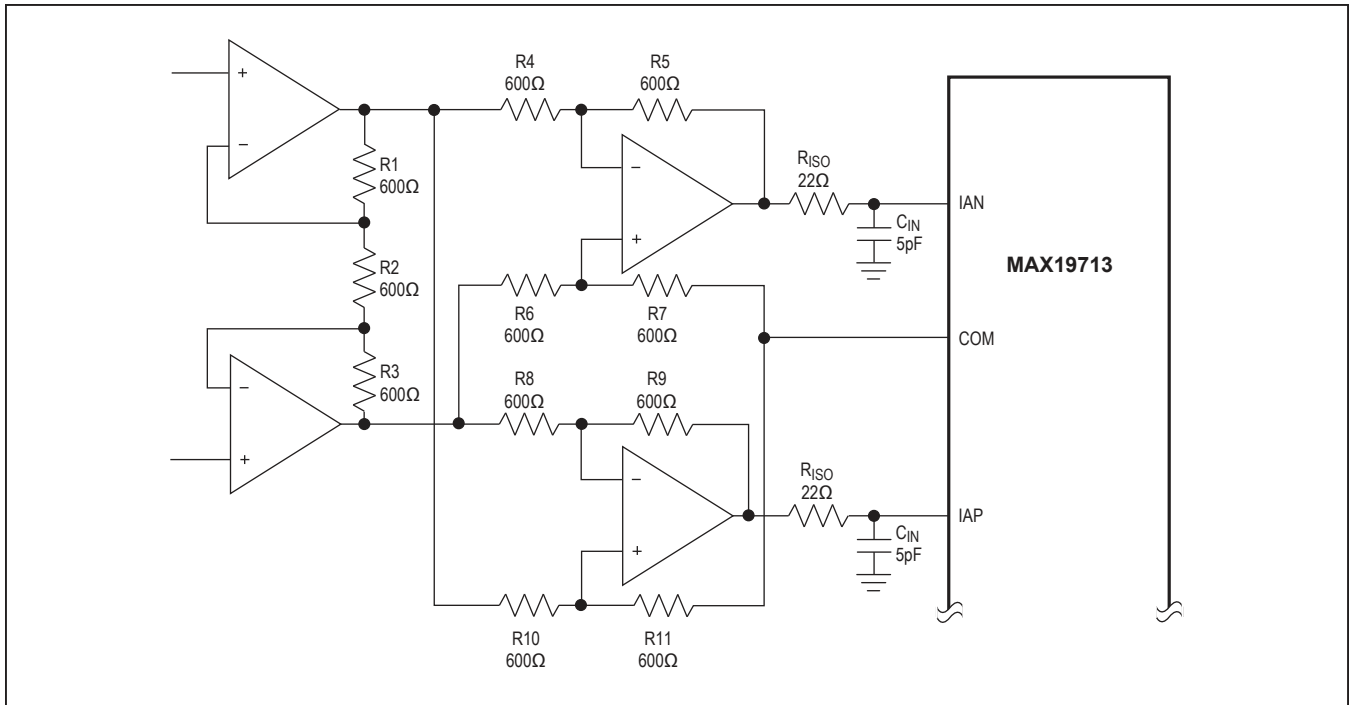

Figure 12. Rx ADC DC-Coupled Differential Drive

capacitor in parallel with a 2.2 μ F capacitor. Bypass REFP, REFN, and COM each to GND with a 0.33 μ F ceramic capacitor. Bypass REFIN to GND with a 0.1 μ F capacitor.

Multilayer boards with separated ground and power planes yield the highest level of signal integrity. Use a split ground plane arranged to match the physical location of the analog ground (GND) and the digital output-driver ground (OGND) on the device package. Connect the MAX19713 exposed backside paddle to the GND plane. Join the two ground planes at a single point so the noisy digital ground currents do not interfere with the analog ground plane. The ideal location for this connection can be determined experimentally at a point along the gap between the two ground planes. Make this connection with a low-value, surface-mount resistor (1 Ω to 5 Ω), a ferrite bead, or a direct short. Alternatively, all ground pins could share the same ground plane, if the ground plane is sufficiently isolated from any noisy digital system's ground

plane (e.g., downstream output buffer or DSP ground plane).

Route high-speed digital signal traces away from sensitive analog traces. Make sure to isolate the analog input lines to each respective converter to minimize channel-to-channel crosstalk. Keep all signal lines short and free of 90° turns.

Dynamic Parameter Definitions

ADC and DAC Static Parameter Definitions

Integral Nonlinearity (INL)

Integral nonlinearity is the deviation of the values on an actual transfer function from a straight line. This straight line can be either a best-straight-line fit or a line drawn between the end points of the transfer function, once offset and gain errors have been nullified. The static linearity parameters for the device are measured using the best-straight-line fit (DAC [Figure 14a](#)).

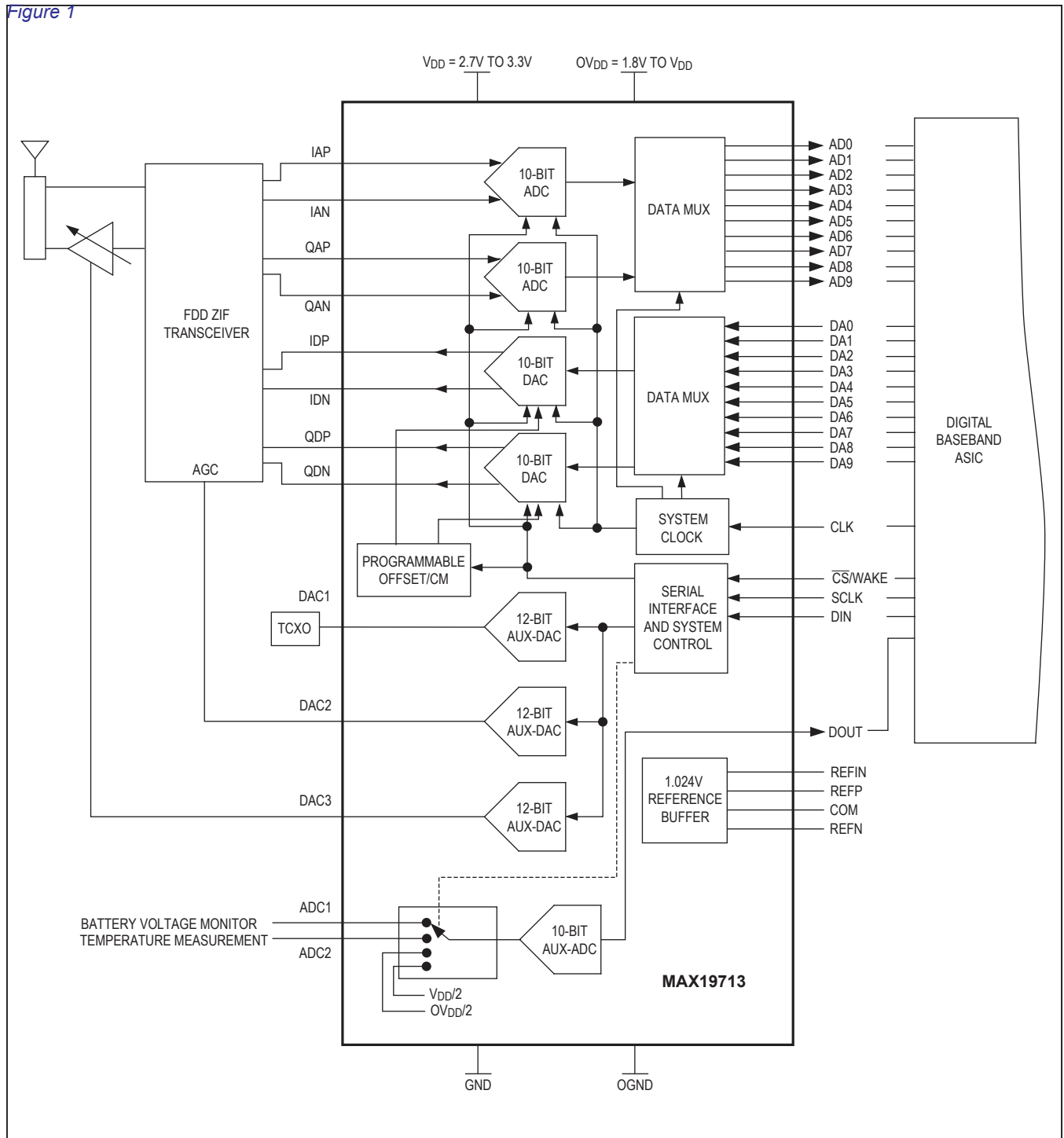

Figure 13. Typical FDD Radio Application Circuit

Differential Nonlinearity (DNL)

Differential nonlinearity is the difference between an actual step width and the ideal value of 1 LSB. A DNL error specification of less than 1 LSB guarantees no missing codes (ADC) and a monotonic transfer function (ADC and DAC) (DAC [Figure 14b](#)).

ADC Offset Error

Ideally, the midscale transition occurs at 0.5 LSB above midscale. The offset error is the amount of deviation between the measured transition point and the ideal transition point.

DAC Offset Error

Offset error ([Figure 14a](#)) is the difference between the ideal and actual offset point. The offset point is the output value when the digital input is midscale. This error affects all codes by the same amount and usually can be compensated by trimming.

ADC Gain Error

Ideally, the ADC full-scale transition occurs at 1.5 LSB below full scale. The gain error is the amount of deviation between the measured transition point and the ideal transition point with the offset error removed.

ADC Dynamic Parameter Definitions

Aperture Jitter

[Figure 15](#) shows the aperture jitter (t_{AJ}), which is the sample-to-sample variation in the aperture delay.

Aperture Delay

Aperture delay (t_{AD}) is the time defined between the rising edge of the sampling clock and the instant when an actual sample is taken ([Figure 15](#)).

Signal-to-Noise Ratio (SNR)

For a waveform perfectly reconstructed from digital samples, the theoretical maximum SNR is the ratio of the full-scale analog input (RMS value) to the RMS quantization error (residual error) and results directly from the ADC's resolution (N bits):

$$SNR(max) = 6.02 \times N + 1.76 \text{ (in dB)}$$

In reality, there are other noise sources besides quantization noise: thermal noise, reference noise, clock jitter, etc. SNR is computed by taking the ratio of the RMS signal to the RMS noise. RMS noise includes all spectral components to the Nyquist frequency excluding the fundamental, the first five harmonics, and the DC offset.

Signal-to-Noise and Distortion (SINAD)

SINAD is computed by taking the ratio of the RMS signal to the RMS noise. RMS noise includes all spectral components to the Nyquist frequency excluding the fundamental and the DC offset.

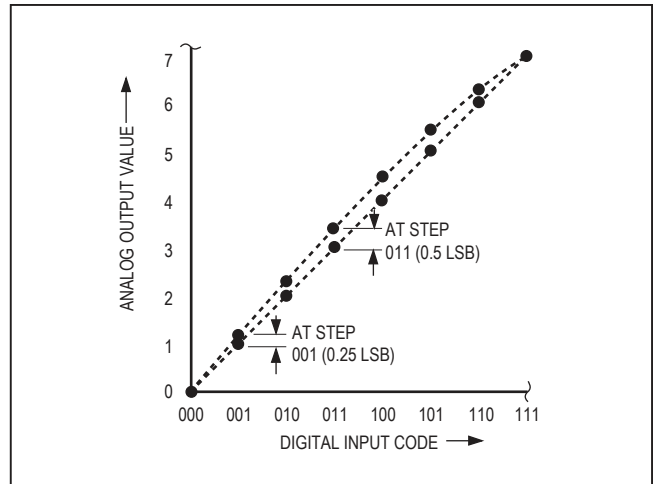

Figure 14a. Integral Nonlinearity

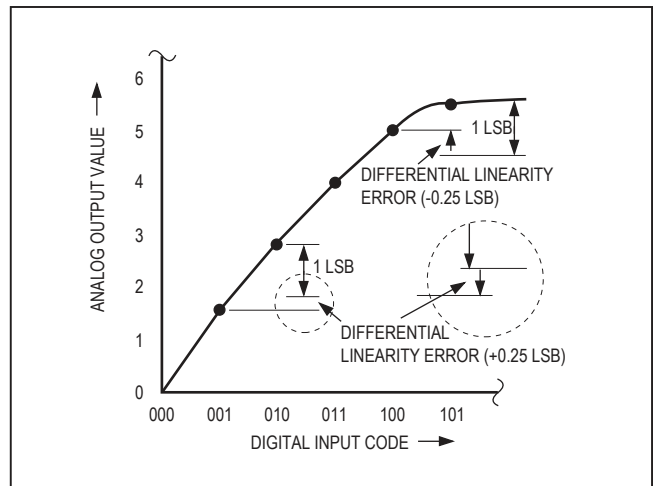

Figure 14b. Differential Nonlinearity

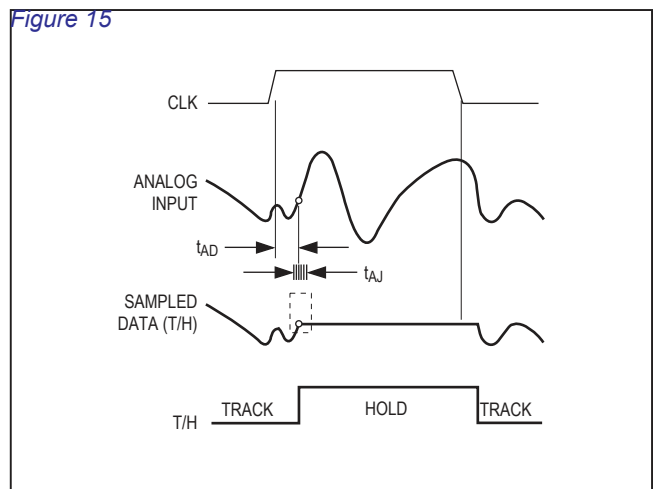

Figure 15. T/H Aperture Timing

Effective Number of Bits (ENOB)

ENOB specifies the dynamic performance of an ADC at a specific input frequency and sampling rate. An ideal ADC's error consists of quantization noise only. ENOB for a full-scale sinusoidal input waveform is computed from:

$$\text{ENOB} = (\text{SINAD} - 1.76)/6.02$$

Total Harmonic Distortion (THD)

THD is typically the ratio of the RMS sum of the first five harmonics of the input signal to the fundamental itself. This is expressed as:

$$\text{THD} = 20 \times \log \left[\frac{\sqrt{V_2^2 + V_3^2 + V_4^2 + V_5^2 + V_6^2}}{V_1} \right]$$

where V_1 is the fundamental amplitude and V_2 – V_6 are the amplitudes of the 2nd- through 6th-order harmonics.

Third Harmonic Distortion (HD3)

HD3 is defined as the ratio of the RMS value of the third harmonic component to the fundamental input signal.

Spurious-Free Dynamic Range (SFDR)

SFDR is the ratio expressed in decibels of the RMS amplitude of the fundamental (maximum signal component) to the RMS value of the next-largest spurious component, excluding DC offset.

Intermodulation Distortion (IMD)

IMD is the total power of the intermodulation product relative to the total input power when two tones, f_{IN1} and f_{IN2} , are present at the inputs. The intermodulation products are $(f_{IN1} \pm f_{IN2})$, $(2 \times f_{IN1})$, $(2 \times f_{IN2})$, $(2 \times f_{IN1} \pm f_{IN2})$, $(2 \times f_{IN2} \pm f_{IN1})$. The individual input tone levels are at -7dBFS.

3rd-Order Intermodulation (IM3)

IM3 is the power of the worst 3rd-order intermodulation product relative to the input power of either input tone when two tones, f_{IN1} and f_{IN2} , are present at the inputs. The 3rd-order intermodulation products are $(2 \times f_{IN1} \pm f_{IN2})$, $(2 \times f_{IN2} \pm f_{IN1})$. The individual input tone levels are at -7dBFS.

Power-Supply Rejection

Power-supply rejection is defined as the shift in offset and gain error when the power supply is changed $\pm 5\%$.

Small-Signal Bandwidth

A small -20dBFS analog input signal is applied to an ADC in such a way that the signal's slew rate does not limit the ADC's performance. The input frequency is then swept up to the point where the amplitude of the digitized conversion result has decreased by 3dB. Note that the T/H performance is usually the limiting factor for the small-signal input bandwidth.

Full-Power Bandwidth

A large -0.5dBFS analog input signal is applied to an ADC, and the input frequency is swept up to the point where the amplitude of the digitized conversion result has decreased by 3dB. This point is defined as the full-power bandwidth frequency.

DAC Dynamic Parameter Definitions**Total Harmonic Distortion**

THD is the ratio of the RMS sum of the output harmonics up to the Nyquist frequency divided by the fundamental:

$$\text{THD} = 20 \times \log \left[\frac{\sqrt{V_2^2 + V_3^2 + \dots + V_n^2}}{V_1} \right]$$

where V_1 is the fundamental amplitude and V_2 through V_n are the amplitudes of the 2nd through nth harmonic up to the Nyquist frequency.

Spurious-Free Dynamic Range

Spurious-free dynamic range (SFDR) is the ratio of RMS amplitude of the fundamental (maximum signal component) to the RMS value of the next-largest distortion component up to the Nyquist frequency excluding DC.

Selector Guide

| PART | SAMPLING RATE (Msps) | INTEGRATED CDMA Tx FILTERS |
|----------|----------------------|----------------------------|
| MAX19710 | 7.5 | No |
| MAX19711 | 11 | Yes |
| MAX19712 | 22 | No |
| MAX19713 | 45 | No |

Functional Diagram

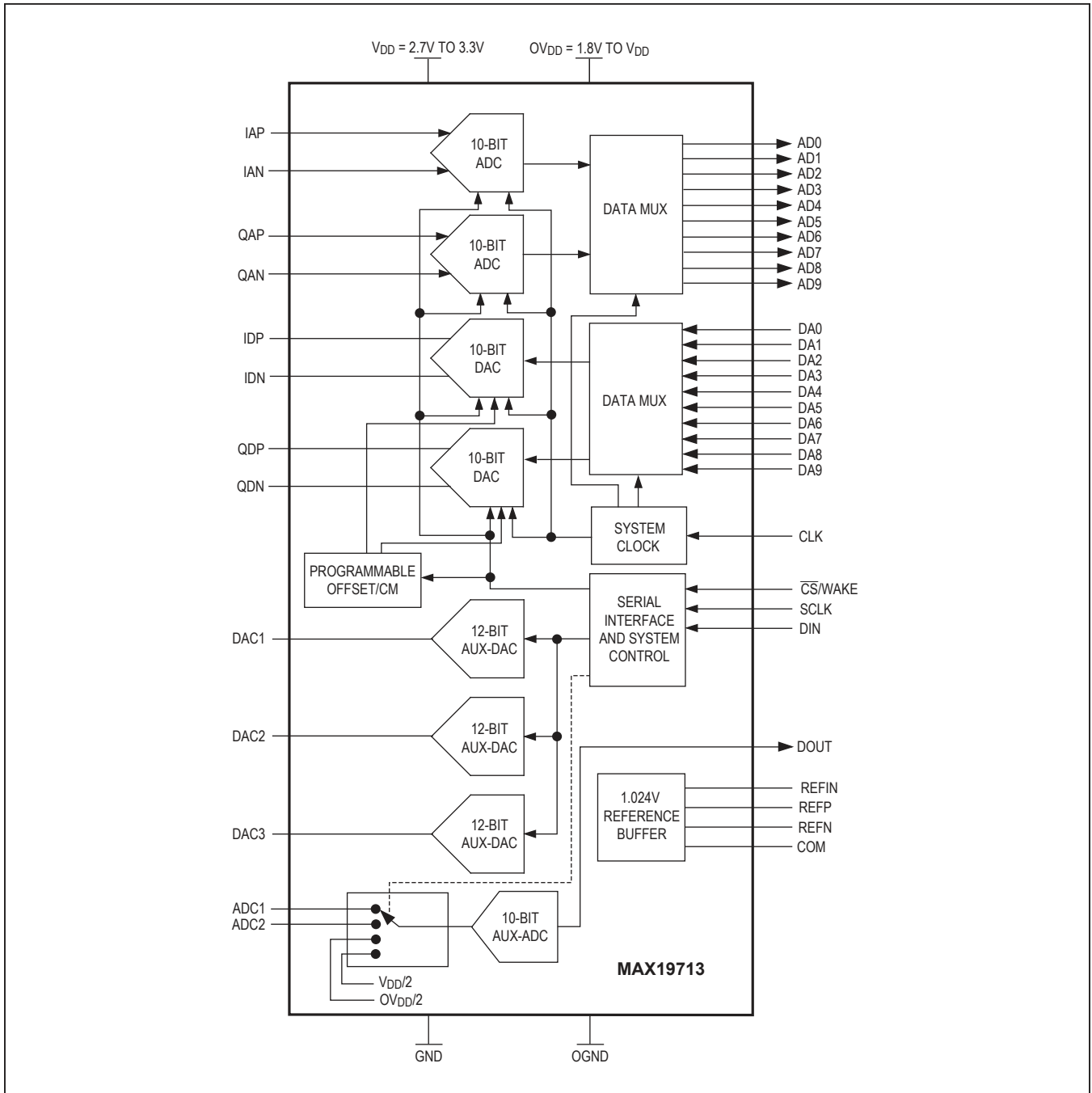

Package Information

For the latest package outline information and land patterns (footprints), go to www.maximintegrated.com/packages. Note that a "+", "#", or "-" in the package code indicates RoHS status only. Package drawings may show a different suffix character, but the drawing pertains to the package regardless of RoHS status.

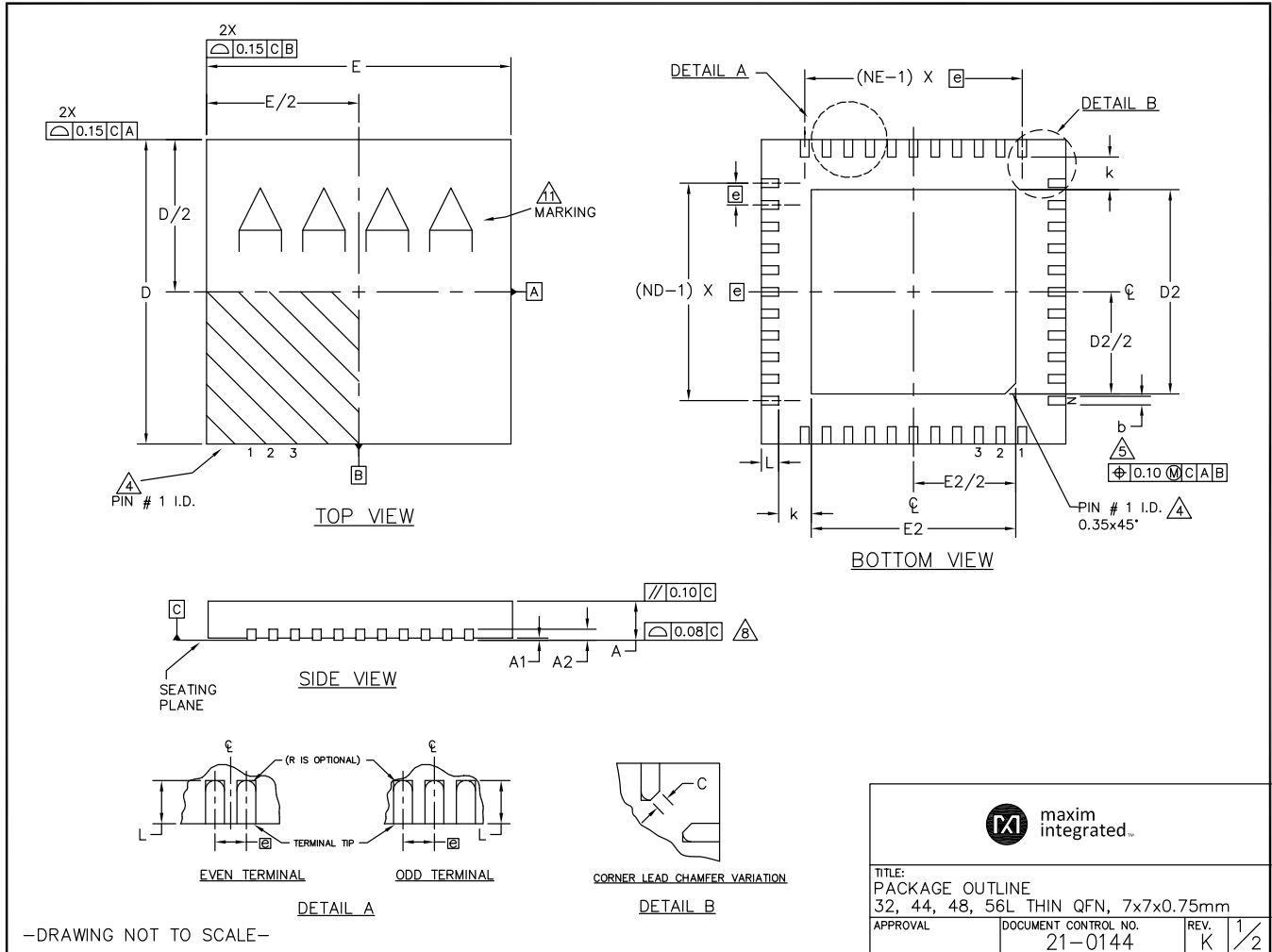

Package Information (continued)

For the latest package outline information and land patterns (footprints), go to www.maximintegrated.com/packages. Note that a "+", "#", or "-" in the package code indicates RoHS status only. Package drawings may show a different suffix character, but the drawing pertains to the package regardless of RoHS status.

| COMMON DIMENSIONS | | | | | | | | | | | | | | | EXPOSED PAD VARIATIONS | | | | | | | | | |
|-------------------|-----------|------|------|-----------|------|------|-----------|------|------|-----------------------|------|------|-----------|------|------------------------|------------|-------------------|------|------|------|------|------|------|--------------------|
| PKG | 32L 7x7 | | | 44L 7x7 | | | 48L 7x7 | | | CUSTOM PKG. (T4877-1) | | | 56L 7x7 | | | PKG. CODES | DEPOPULATED LEADS | D2 | | | E2 | | | JEDEC MO220 REV. C |
| | SYMBOL | MIN. | NOM. | MAX. | MIN. | NOM. | MAX. | MIN. | NOM. | MAX. | MIN. | NOM. | MAX. | MIN. | NOM. | | | MAX. | MIN. | NOM. | MAX. | | | |
| A | 0.70 | 0.75 | 0.80 | 0.70 | 0.75 | 0.80 | 0.70 | 0.75 | 0.80 | 0.70 | 0.75 | 0.80 | 0.70 | 0.75 | 0.80 | T3277-2 | - | 4.55 | 4.70 | 4.85 | 4.55 | 4.70 | 4.85 | - |
| A1 | 0 | 0.02 | 0.05 | 0 | 0.02 | 0.05 | 0 | 0.02 | 0.05 | 0 | 0.02 | 0.05 | 0 | - | 0.05 | T3277-3 | - | 4.55 | 4.70 | 4.85 | 4.55 | 4.70 | 4.85 | WKKD-1 |
| A2 | 0.20 REF. | | | 0.20 REF. | | | 0.20 REF. | | | 0.20 REF. | | | 0.20 REF. | | | T4477-2 | - | 4.55 | 4.70 | 4.85 | 4.55 | 4.70 | 4.85 | WKKD-1 |
| b | 0.25 | 0.30 | 0.35 | 0.20 | 0.25 | 0.30 | 0.20 | 0.25 | 0.30 | 0.20 | 0.25 | 0.30 | 0.15 | 0.20 | 0.25 | T4477-3 | - | 4.55 | 4.70 | 4.85 | 4.55 | 4.70 | 4.85 | WKKD-1 |
| D | 6.90 | 7.00 | 7.10 | 6.90 | 7.00 | 7.10 | 6.90 | 7.00 | 7.10 | 6.90 | 7.00 | 7.10 | 6.90 | 7.00 | 7.10 | T4877-3 | - | 4.95 | 5.10 | 5.25 | 4.95 | 5.10 | 5.25 | - |
| E | 6.90 | 7.00 | 7.10 | 6.90 | 7.00 | 7.10 | 6.90 | 7.00 | 7.10 | 6.90 | 7.00 | 7.10 | 6.90 | 7.00 | 7.10 | T4877-4 | - | 5.40 | 5.50 | 5.60 | 5.40 | 5.50 | 5.60 | - |
| e | 0.65 BSC. | | | 0.50 BSC. | | | 0.50 BSC. | | | 0.50 BSC. | | | 0.40 BSC. | | | T4877-6 | - | 5.40 | 5.50 | 5.60 | 5.40 | 5.50 | 5.60 | - |
| k | 0.25 | - | - | 0.25 | - | - | 0.25 | - | - | 0.25 | - | - | 0.25 | - | - | T4877-7 | - | 4.95 | 5.10 | 5.25 | 4.95 | 5.10 | 5.25 | - |
| L | 0.45 | 0.55 | 0.65 | 0.45 | 0.55 | 0.65 | 0.30 | 0.40 | 0.50 | 0.45 | 0.55 | 0.65 | 0.30 | 0.40 | 0.50 | T4877M-1 | - | 5.40 | 5.50 | 5.60 | 5.40 | 5.50 | 5.60 | - |
| N | 32 | | | 44 | | | 48 | | | 44 | | | 56 | | | T4877M-6 | - | 5.40 | 5.50 | 5.60 | 5.40 | 5.50 | 5.60 | - |
| ND | 8 | | | 11 | | | 12 | | | 10 | | | 14 | | | T4877MN-8 | - | 5.40 | 5.50 | 5.60 | 5.40 | 5.50 | 5.60 | - |
| NE | 8 | | | 11 | | | 12 | | | 12 | | | 14 | | | T4877N-8 | - | 5.40 | 5.50 | 5.60 | 5.40 | 5.50 | 5.60 | - |
| | | | | | | | | | | | | | | | T5677-1 | - | 5.40 | 5.50 | 5.60 | 5.40 | 5.50 | 5.60 | - | |
| | | | | | | | | | | | | | | | T5677MN-1 | - | 5.40 | 5.50 | 5.60 | 5.40 | 5.50 | 5.60 | - | |
| | | | | | | | | | | | | | | | T5677-2 | - | 5.40 | 5.50 | 5.60 | 5.40 | 5.50 | 5.60 | - | |
| | | | | | | | | | | | | | | | T5677-3 | - | 5.40 | 5.50 | 5.60 | 5.40 | 5.50 | 5.60 | - | |

NOTES:

- DIMENSIONING & TOLERANCING CONFORM TO ASME Y14.5M-1994.
- ALL DIMENSIONS ARE IN MILLIMETERS. ANGLES ARE IN DEGREES.
- N IS THE TOTAL NUMBER OF TERMINALS.
- THE TERMINAL #1 IDENTIFIER AND TERMINAL NUMBERING CONVENTION SHALL CONFORM TO JESD 95-1 SPP-012. DETAILS OF TERMINAL #1 IDENTIFIER ARE OPTIONAL, BUT MUST BE LOCATED WITHIN THE ZONE INDICATED. THE TERMINAL #1 IDENTIFIER MAY BE EITHER A MOLD OR MARKED FEATURE.
- DIMENSION b APPLIES TO METALLIZED TERMINAL AND IS MEASURED BETWEEN 0.25 mm AND 0.30 mm FROM TERMINAL TIP.
- ND AND NE REFER TO THE NUMBER OF TERMINALS ON EACH D AND E SIDE RESPECTIVELY.
- DEPOPULATION IS POSSIBLE IN A SYMMETRICAL FASHION.
- COPLANARITY APPLIES TO THE EXPOSED HEAT SINK SLUG AS WELL AS THE TERMINALS.
- DRAWING CONFORMS TO JEDEC MO220 EXCEPT THE EXPOSED PAD DIMENSIONS OF T4877-3/-4/-6 & T5677-1.
- WARPAGE SHALL NOT EXCEED 0.10 mm.
- MARKING IS FOR PACKAGE ORIENTATION REFERENCE ONLY.
- NUMBER OF LEADS SHOWN ARE FOR REFERENCE ONLY.
- ALL DIMENSIONS APPLY TO BOTH LEADED (-) AND PbFREE (+) PKG. CODES.

| CORNER LEAD CHAMFER VARIATION | |
|-------------------------------|-------------|
| PKG. CODES | C |
| T4877-3 | 0.115 X 45° |
| T4877-4 | 0.115 X 45° |
| T4877-6 | 0.115 X 45° |
| T4877-7 | 0.115 X 45° |
| T4877M-1 | 0.115 X 45° |
| T4877M-6 | 0.115 X 45° |

TITLE:
PACKAGE OUTLINE
32, 44, 48, 56L THIN QFN, 7x7x0.75mm

APPROVAL _____ DOCUMENT CONTROL NO. 21-0144 REV. K 2/2

-DRAWING NOT TO SCALE-

Revision History

Pages changed at Rev 1: 1-4, 29, 37

For pricing, delivery, and ordering information, please contact Maxim Direct at 1-888-629-4642, or visit Maxim Integrated's website at www.maximintegrated.com.

Maxim Integrated cannot assume responsibility for use of any circuitry other than circuitry entirely embodied in a Maxim Integrated product. No circuit patent licenses are implied. Maxim Integrated reserves the right to change the circuitry and specifications without notice at any time. The parametric values (min and max limits) shown in the Electrical Characteristics table are guaranteed. Other parametric values quoted in this data sheet are provided for guidance.