

Mechanical Dimensions: Inches [mm]

Tolerances ± 0.012 [0.3] Unless Otherwise Specified

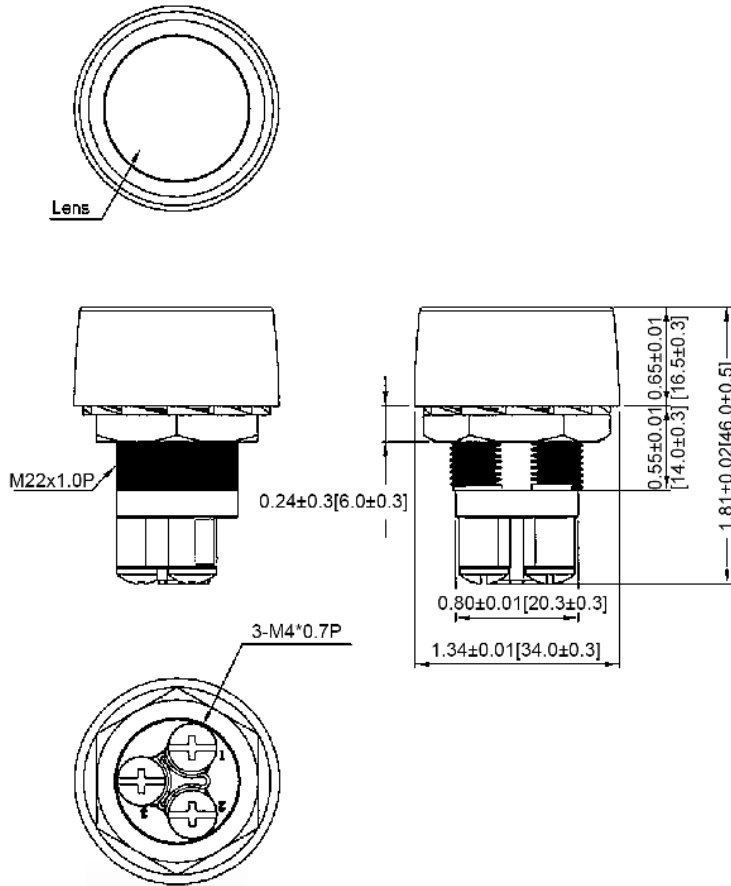

Mounting Hole

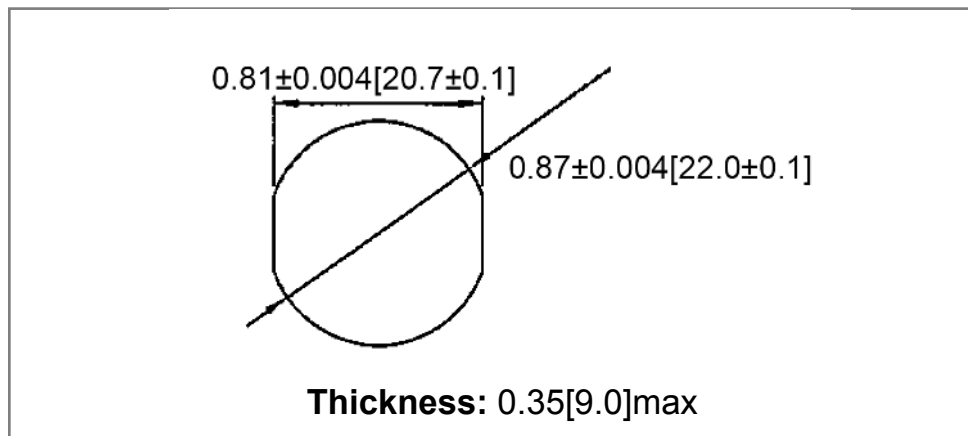

Circuit Diagram

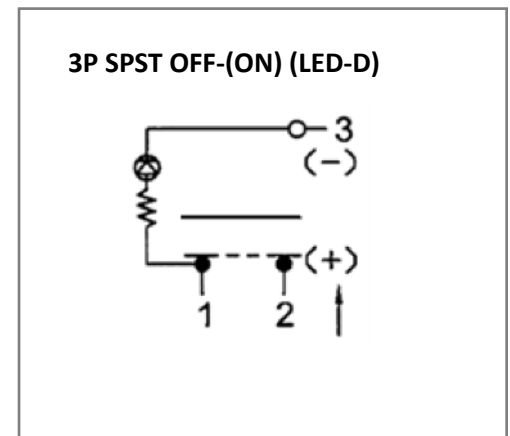

Electrical Specifications

Rating	50A 12V DC
Contact Resistance	50m ohm Max
Insulation Resistance	DC 500V 100M ohm Min
Dielectric Strength	AC 1500V 1 minute
Operation Temperature	-25°C ~ 85°C

Material Specifications

Frame	Black, Nylon 66 (94V-2)
Cover	Black, ABS (94HB)
Terminals	Copper alloy (Brass)
LED	ø5.0 Green diffused
Actuator	Green, PC (94V-2) White, Hot stamping

Rev	Date of issue	Revision Notes	Designed	Approved
B	04-15-2020	Initial Drawing	RC	OF