

THIS DRAWING IS UNPUBLISHED. RELEASED FOR PUBLICATION, 19 .  
 © COPYRIGHT 19 BY AMP INCORPORATED. ALL INTERNATIONAL RIGHTS RESERVED.

LOC	DIST	P	F	REVISIONS				
AF	50			ZONE	LTR	DESCRIPTION	DATE	APPD
					0	DRAWN	8/16/95	JR/PD

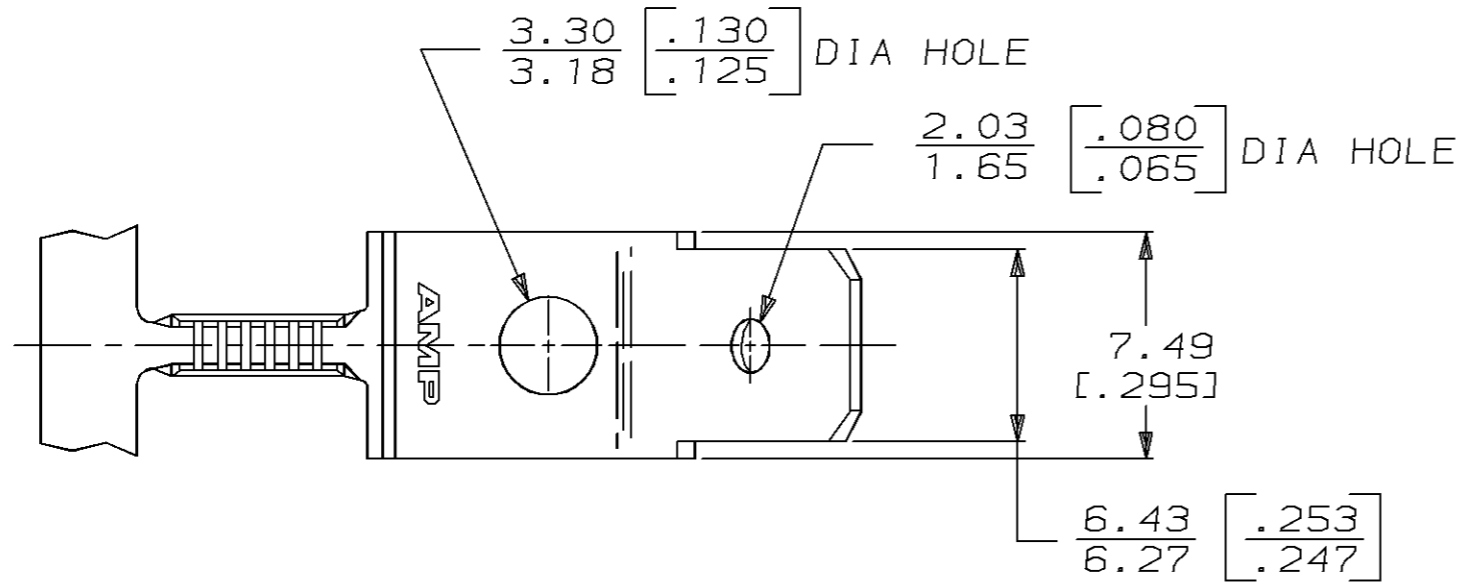

- CONTINUOUS STRIP ON REELS.
- TAB DIMENSIONS ARE IN ACCORDANCE WITH NEMA DC-2 STD.

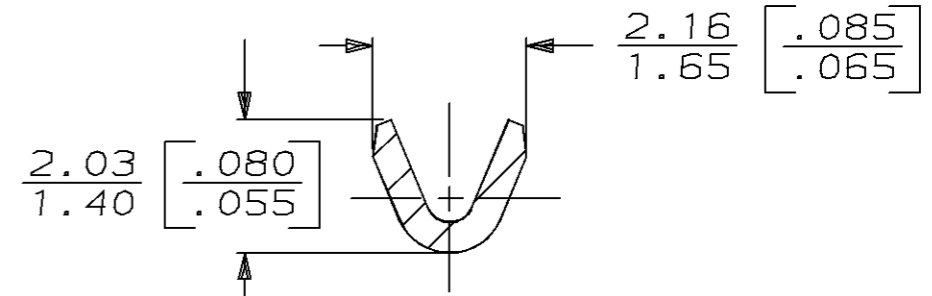
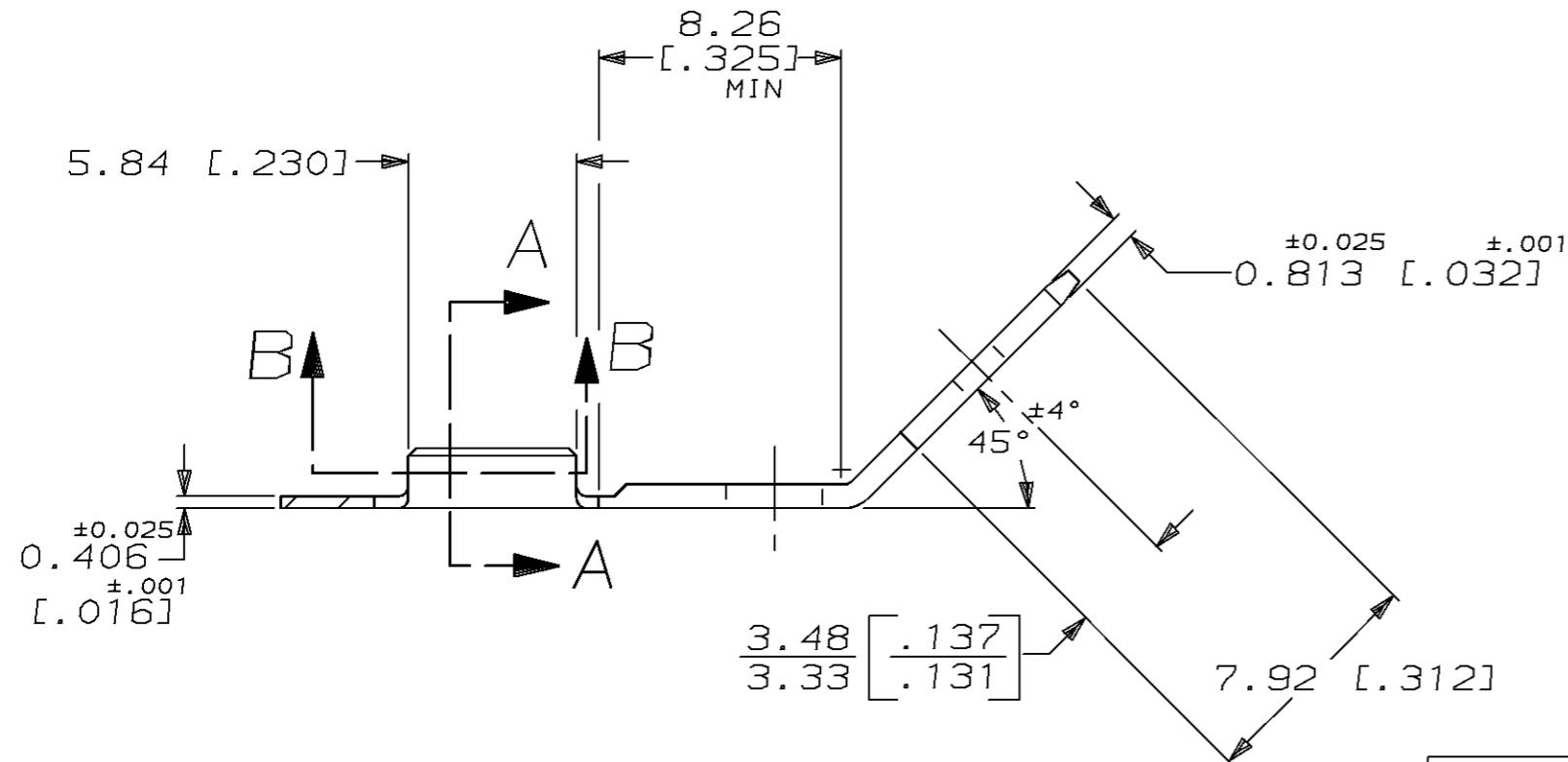

SECTION A-A  
SCALE 10:1

200-566 CMA	63611-1
WIRE RANGE	PART NO
<b>AMP</b> AMP Incorporated Harrisburg, PA 17105-3608	
NAME TAB, FASTON™ AMPLIVAR, 6.35 [ .250 ] SERIES	
SIZE <b>B</b>	CAGE CODE 00779
SCALE 4:1	DRAWING NO 63611
	SHEET 1 OF 1

DO NOT SCALE PRINT. UNLESS SPECIFIED DIMENSIONS IN mm [INCHES] TOLERANCES ON: 2 PLC DEC ± 0.25 [ .010 ] 3 PLC DEC ± - ANGLES ± -	DR 8/16/95 JR RUTH
	CHK 8/16/95 MS FEHER
	APPD 8/16/95 P DESANTIS
MATERIAL PREMILLED #2H BRASS	APPD 8/16/95 D REINER
FINISH TIN 0.002032 [ .000080 ] MIN WITH VARNISH RESIST	PRODUCT SPEC -
	APPLICATION SPEC -
	WEIGHT -