

LOC	DATE	REVISIONS	DATE	BY	APP'D
AA	22				
B		REV PER ECO-08-026213	04SEP2008	RQ	TX
C		ECO-11-015766	30MAY2011	EL	LR

MECHANICAL:

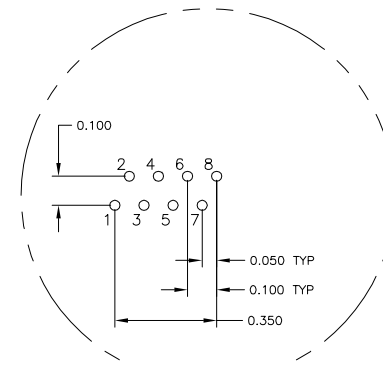

Pin Designations

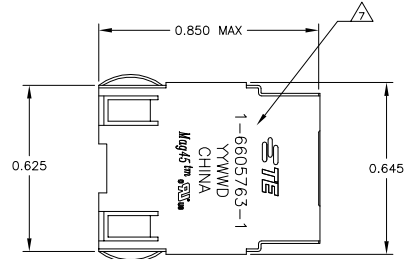
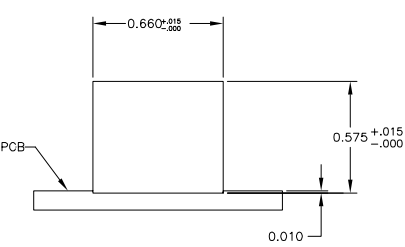
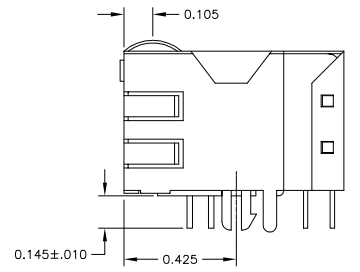
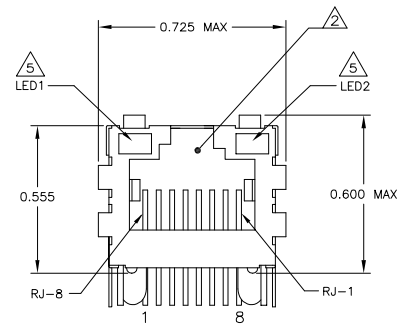

Suggested Panel Cutout

726P1 SERIES MAGNETIC CIRCUIT

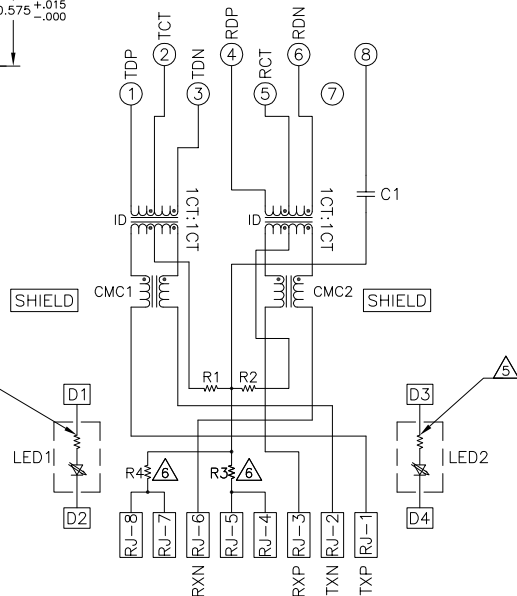

C1=1000pF, 2kV CAPACITOR
R1-R4 = 75 OHMS, 1/16 W RESISTORS

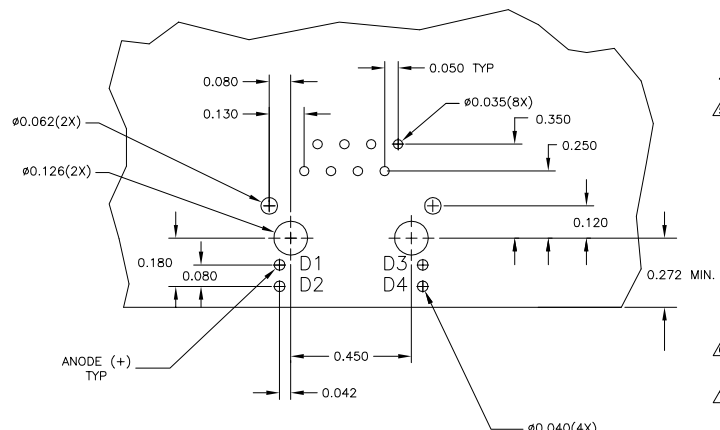

Suggested PCB Layout (Component Side)

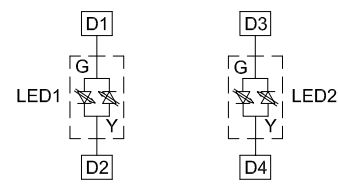

LED CONFIGURATION FOR 5-6605763-6 ONLY

- MATERIALS:**
- HOUSING - THERMOPLASTIC PET POLYESTER FLAMMABILITY RATING UL 94V-0.
 - SHIELD - .010" THICK, C26800 BRASS PREPLATED WITH 30μINCH MIN SEMI-BRIGHT NICKEL, SOLDER TABS POST DIPPED WITH 100μINCH MIN SAC SOLDER.
 - MOD JACK CONTACTS - 0.0157" x 0.018" PHOSPHOR BRONZE, 50μINCH MIN OVERALL NICKEL UNDERPLATE, WITH SELECT 50μINCH MIN HARD GOLD FINISH PLATE. SOLDER TAILS WITH 100μINCH MIN MATTE TIN AND/OR SAC SOLDER DIP.
 - LIGHT EMITTING DIODE(LED) - DIFFUSED EPOXY LENS, .020" x .020" CARBON STEEL WIREFRAME LEADS PRE-PLATED WITH 80μINCH SILVER OVER 4.0μINCH NICKEL UNDERPLATE OVER 4.0μINCH COPPER UNDERPLATE, POST-PLATED WITH 100μINCH MIN MATTE TIN AND/OR SAC SOLDER DIP OR PURE TIN SOLDER DIP.
- RJ45 JACK CAVITY CONFORMS TO FCC RULES AND REGULATIONS PART 68, SUB PART F.**
- MAGNETICS**
- IMPEDANCE: 100 OHMS
 - TURNS RATIO (CHIP: CABLE): TX = 1:1, RX = 1:1
 - OPEN CIRCUIT INDUCTANCE (OCL): 350μH MIN @100kHz, 0.1VRMS, 8mADC BIAS FROM 0°C TO 70°C, TX AND RX
 - PERFORMANCE @ 25°C:
- INSERTION LOSS (IL): 1.1dB MAX FROM 0.5MHz TO 100MHz
 - RETURN LOSS (RL): 18dB MIN FROM 0.5MHz TO 30MHz
 - 18-20LOG(f/30)dB MIN FROM 30.1MHz TO 60MHz
 - 12dB MIN FROM 60.1MHz TO 80MHz
 - CROSSTALK ATTENUATION: 35dB MIN FROM 0.5MHz TO 40MHz
 - 33-20*LOG(f/50)dB MIN FROM 40.1MHz TO 100MHz
 - COMMON MODE REJECTION RATIO (CMRR): 30dB MIN FROM 0.5MHz TO 100MHz
 - ISOLATION VOLTAGE: 2250VDC (MAX) FOR 60 SECONDS WITH A RISE TIME OF 500V/SEC.
- 4. OPERATING TEMPERATURE FROM 0°C - +70°C**
- THE 250 OHM LED RESISTORS ARE OPTIONAL. PLEASE SEE CHART FOR PRESENCE OR ABSENCE OF LED RESISTORS. IF THE LED WITHOUT 250 OHM RESISTORS, LED IS DRIVEN WITH CONSTANT CURRENT AT APPROX 20mA**
- LED COLOR: DOMINANT WAVELENGTH (AD): GREEN 568 nm TYP @ IF=20mA
FORWARD VOLTAGE (VF): GREEN 2.2V TYP @ IF=20mA
DOMINANT WAVELENGTH (AD): YELLOW 588 nm TYP @ IF=20mA
FORWARD VOLTAGE (VF): YELLOW 2.1V TYP @ IF=20mA.
- IF THE LED WITH 250 OHM RESISTORS, LED IS DRIVEN WITH 5V VOLTAGE AND THE MAX OPERATING CURRENT IS 20mA.**
- LED COLOR: DOMINANT WAVELENGTH (AD): GREEN 568 nm TYP @ VF=5V
FORWARD CURRENT (IF): GREEN 12 mA TYP @ VF=5V
DOMINANT WAVELENGTH (AD): YELLOW 588 nm TYP @ VF=5V
FORWARD CURRENT (IF): YELLOW 13 mA TYP @ VF=5V
- INDICATED CONNECTIONS ARE FOR NIC CONFIGURATION. THE MAGNETICS ARE SYMMETRICAL, AND THEREFORE ARE AUTO-MDI/MDIX CAPABLE.**
- TE CONNECTIVITY LOGO, PART NUMBER, DATE CODE, COUNTRY OF ORIGIN AND AGENCY APPROVAL MARKING IN APPROXIMATE LOCATION SHOWN.**
- 8. THESE PARTS ARE RECOMMENDED FOR WAVE SOLDERING PROCESS. PREHEAT TEMPERATURE IS 120°C TO 160°C, 120 SECONDS TO 180 SECONDS, PEAK SOLDERING TEMPERATURE IS 260 °C MAX, 10 SECONDS MAX.**

GREEN	NO	GREEN	NO	5-6605763-7
GREEN/YELLOW	NO	GREEN/YELLOW	NO	5-6605763-6
GREEN	YES	GREEN	YES	1-6605763-1
LED1	250 OHMS RESISTOR	LED2	250 OHMS RESISTOR	PART NUMBER

DIMENSIONS:		DRAWING NO		SCALE		SHEET	
INCHES:	0.100	108-2100	A1	100%	1	1	1
MATERIAL:	TE CONNECTIVITY	1X1 MAG45(TM), 726P1 SCHEMATIC, 726 SERIES CIRCUIT, SHIELDED, DECOUPLING CAPACITOR, WITH LEDs	00779	6605763			