

# Mechanical Drawing

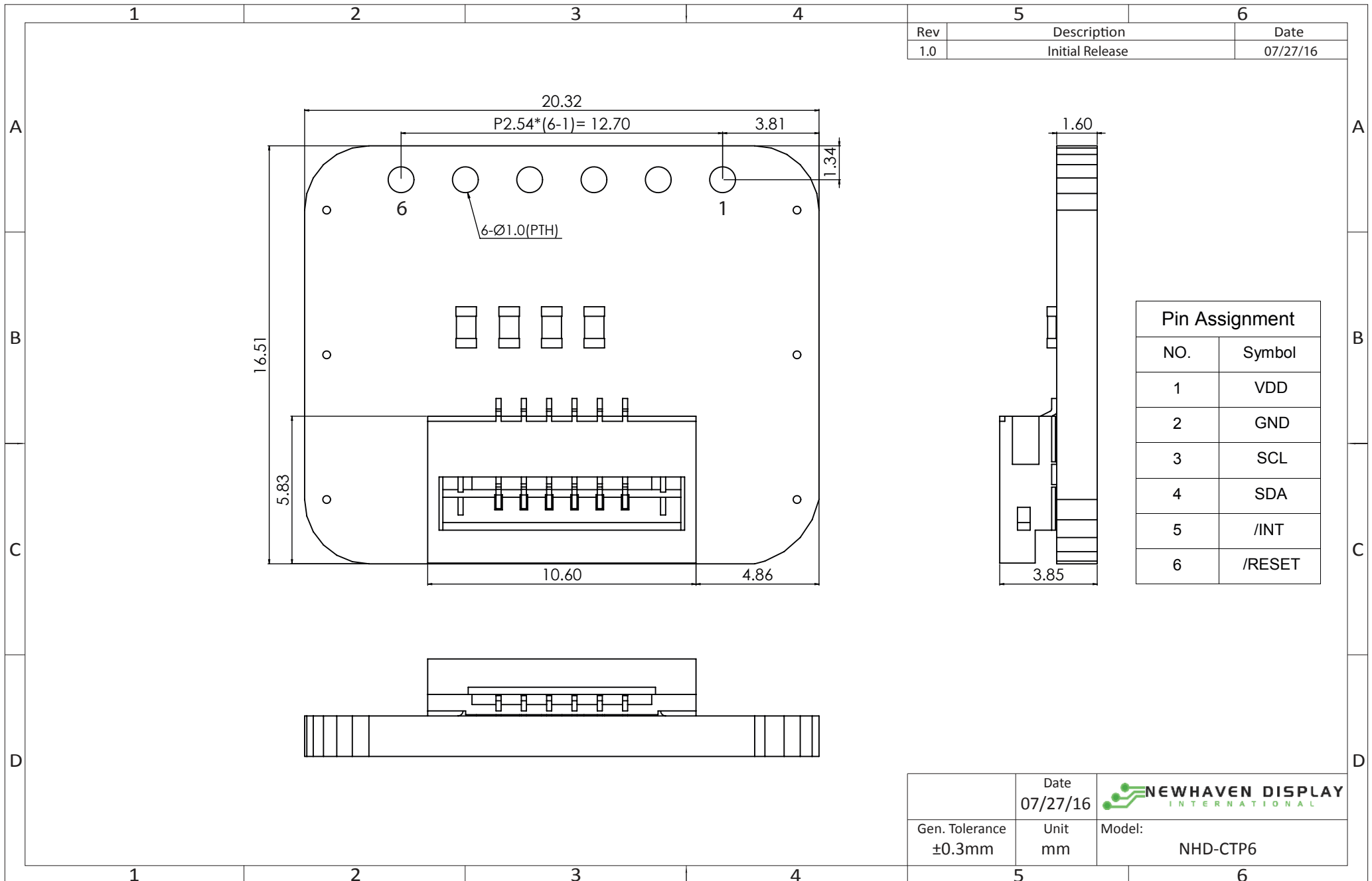

# Schematic

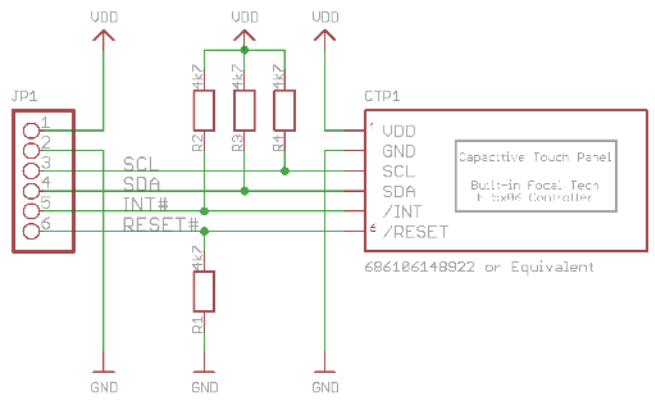

NHD-CTP6	
8/26/2016 12:32:57 PM	Drawn: P.Bartek
Revision: 1.0	Sheet: 1/1
Released under the Creative Commons Attribution Share-Alike 4.0 License <a href="http://creativecommons.org/licenses/by-sa/4.0">http://creativecommons.org/licenses/by-sa/4.0</a>	

