

# nRFready Microphone

nRF6915/AKMS\_MIC\_2

User Guide v1.0



## Liability disclaimer

Nordic Semiconductor ASA reserves the right to make changes without further notice to the product to improve reliability, function or design. Nordic Semiconductor ASA does not assume any liability arising out of the application or use of any product or circuits described herein.

## Life support applications

These products are not designed for use in life support appliances, devices, or systems where malfunction of these products can reasonably be expected to result in personal injury. Nordic Semiconductor ASA customers using or selling these products for use in such applications do so at their own risk and agree to fully indemnify Nordic Semiconductor ASA for any damages resulting from such improper use or sale.

## Contact details

For your nearest dealer, please see <http://www.nordicsemi.com>

Receive available updates automatically by subscribing to eNews from our homepage or check our website regularly for any available updates.

### Main office:

Otto Niensens veg 12  
7004 Trondheim  
Phone: +47 72 89 89 00  
Fax: +47 72 89 89 89  
[www.nordicsemi.com](http://www.nordicsemi.com)



## Revision History

Date	Version	Description
November 2011	1.0	

---

## Contents

<b>1</b>	<b>Introduction .....</b>	<b>4</b>
1.1	Who should read this User Guide? .....	4
1.2	System requirements .....	4
1.3	Required reading .....	4
1.4	Writing Conventions.....	5
<b>2</b>	<b>Kit content.....</b>	<b>6</b>
2.1	Hardware content .....	6
2.2	Firmware content .....	6
2.3	Documentation.....	7
2.4	Finding content on the web.....	7
<b>3</b>	<b>System overview .....</b>	<b>8</b>
<b>4</b>	<b>Kit operation .....</b>	<b>10</b>
4.1	Pairing procedure .....	11
4.2	Programming boards .....	11
4.3	Compiling firmware .....	12
<b>5</b>	<b>Hardware description.....</b>	<b>13</b>
5.1	nRF2788 Microphone .....	13
5.2	nRF2789 Receiver .....	14
5.3	Layout guidelines .....	15
5.4	Power supply .....	15
5.5	Antenna .....	16
5.6	Crystal oscillator .....	16
5.7	User interface .....	16
5.8	Programming interface .....	17
5.9	RF regulation .....	17
<b>6</b>	<b>Troubleshooting .....</b>	<b>17</b>

## 1 Introduction

The nRFready Microphone Reference Design Kit is a complete hardware and firmware reference design for a dual 2.4 GHz RF wireless microphone set. Moreover this design is a completely wireless RF solution. This means you are not inconvenienced by cables that curl, form knots, or cause people to trip. Furthermore, RF doesn't require line of sight to operate, as infrared (IR) solutions do.

This reference design is an ideal starting point for developing wireless microphones for gaming, home karaoke and conference room microphone applications. Jointly developed by AKM Semiconductor and Nordic Semiconductor, the nRFready Microphone is based on the Nordic Semiconductor nRF2460 2.4 GHz RF mono audio streamer and AKM Semiconductor audio converters.

The Reference Design Kit is delivered programmed and pre-paired, and there is no special user procedure required to start evaluating the nRFready Microphone design. Follow the Getting Started Guide to quickly set up the Kit to start streaming audio from two microphones to one receiver.

The Kit includes two microphone boards, a receiver board with both analog and USB audio interface, plus a complete set of design files, source code and documentation.

The nRFready Microphone Reference Kit Design has the following key features:

- Complete reference design for a dual 2.4 GHz RF microphone system
- Uncompressed 16-bit digital audio
- 32 kHz sampling rate
- Programmable latency from 20 to 26 ms
- Excellent battery lifetime
- Low-cost Bill of Material (BOM)
- 2 microphone boards with microphone pre-amp input
- 1 receiver board with analog and USB output
- Downloadable full source code, hardware designs files and documentation

### 1.1 Who should read this User Guide?

Anyone developing a wireless microphone design using the nRF2460 should read this User Guide. To fully understand this User Guide a background in software development and/or electronic engineering is required.

### 1.2 System requirements

To use the nRFready Microphone Reference Design Kit you need the following:

- Computer with USB port or audio amplifier with analog input
- Microphone or MP3 player with mini-jack output

### 1.3 Required reading

To use the Kit as is, you need only to read the Getting Started Guide. To develop or customize the Kit, the product specifications for the various ICs used on the boards must also be read.

## 1.4 Writing Conventions

This User Guide follows a set of typographic rules to make the document consistent and easy to read. The following writing conventions are used:

- Commands are written in `Courier New`.
- Pin names are written in **`Courier New`**.
- File names and User Interface components are written in **bold**.
- Cross references are [underlined and highlighted in blue](#).

## 2 Kit content



Figure 1. nRFReady Microphone Development Kit content

### 2.1 Hardware content

The nRFReady Microphone hardware consists of:

- 2 microphone boards
- 1 receiver board
- 2 AAA battery holders
- 4 AAA batteries
- 1 USB cable

### 2.2 Firmware content

The nRFReady Microphone firmware consists of:

- Microphone source code with pre-compiled HEX files
- Receiver source code with pre-compiled HEX file

## 2.3 Documentation

nRFready Microphone documentation consists of:

- nRFready Microphone User Guide (this document)
- nRFready Microphone Getting Started Guide
- Layout files in Altium Designer, Bill of Materials, schematics, and gerber files
- FCC and ETSI pre-compliance reports

## 2.4 Finding content on the web

Follow the Getting Started Guide in order to find the source code and documentation for the nRFready Microphone. Then download and unzip the files to a folder on your PC that you want to use for development.

To be able to compile the source code and program the boards, three programs are required in addition to a PICkit 2™ (or PICkit 3™) programmer. All programs are verified to work on a PC running Windows 7, 64-bit. The programs must be downloaded from <http://www.microchip.com>.

- PICkit2™ Programmer v2.61 (or PICkit3™)
- MPLAB IDE v8.76
- HI-TECH C Compiler for PIC10/12/16 MCUs v9.82 ( a Lite license can be used)

The PICkit2™ (or PICkit3™) programmer must be bought separately since it is not included in this kit.

The product specifications for the analog converters from AKM Semiconductors are available for download from [www.akm.com](http://www.akm.com).



### 3 System overview

As technology has evolved, microphone applications have changed. One might say the trend has gone from technology mainly used on the TV, to technology mainly used *in front of* the TV.

All video game consoles, for example, have one or more music video games which require microphones. This allows children, as well as adults, to sing to the music of their favorite artists.



Figure 2. Typical microphone setup

The system consists of two microphones and a receiver:

- Microphones: These are the audio input devices that the user typically will hold in his hand while singing or talking.
- Receiver: This is the audio output device that the user typically has connected to a computer to record or playback audio.

The system is designed to be simple to set up and use, with only one button and LED on the microphone board, and one button and two LEDs on the receiver board. The buttons are used to power ON/OFF or pair the boards, while the LEDs indicate link or pairing status to the user.

Two AAA batteries are used to power the microphone, and re-chargeable batteries can be used due to an on-board DC/DC converter. With continuous use, the batteries should last for up to 100 hours. To decrease the power consumption, one can consider removing the LED on the microphone board and thereby only having LEDs on the receiver for status indication.



All the communication in the system is digital and packet-based, which means that data between the units is exchanged as discrete packets of information. The raw audio throughput of each microphone is 32 kHz x 16bit = 512 kbps, while the on-air data rate of the packet-based communication is 4 Mbps. This additional bandwidth allows the system to cope with tough interference and yet maintain un-interrupted audio between microphones and receiver.

The nRF2460 wireless audio streamer used in the system, monitors and handles all real-time tasks, such as adaptive frequency hopping, retransmission of lost audio packets, acknowledgements, synchronization, audio buffers and link quality. The receiver board has two nRF2460s that are placed on the same PCB, and the nRF2460 has a built-in synchronization mechanism that allows the two nRF2460s to operate in close proximity, yet without interfering with each other. In addition the two microphones use non-overlapping hopping tables that are spread across the entire 2.4 GHz band to avoid co-channel interference.

The nRF2460 has configurable latency. Using the high latency setting provides the most robust audio link due to the increased time to retransmit. The latency is configurable from 20 to 26 ms, and in this system the highest audio setting is used.

This design supports two microphones to be used at any time. Just insert batteries, turn on the microphones, connect the receiver to the appropriate input, and start singing or talking.

## 4 Kit operation

When connecting the receiver board to the computer, the receiver board will identify itself as a standard sound card that can record audio on the computer. Alternatively, analog output from the RCA sockets can be connected to an audio amplifier input. Both options require that the receiver board is powered from the USB connector.

There are two 2-pin headers on the receiver board. A jumper across pin 1-2 on header P3 is required for the receiver board to work with a PC. Header P4 is not used. See [Table 1](#). for a description of jumper settings.

Jumper across header	Description
P3, pin 1–2	USB enable
P4, pin 1–2	Not used

*Table 1. Jumper settings on the receiver board*

After the receiver board has been powered up, alternate blinking lights on the two LEDs indicate that the receiver board is waiting for a microphone to link up. After link-up, a solid light on either of the LEDs will indicate that a microphone is connected. Similarly, on the microphone board, a blinking LED means that there is no link with a receiver yet, while a solid LED means that the microphone has successfully linked with a receiver board. See [Table 2](#). for a description of LED status.

Status LED	Description
No light <sup>a</sup>	Power off
Rapid blinking	Pairing mode
Slow blinking	Link-up mode
Steady light	Streaming mode

a. Microphone board only

*Table 2. LED indication*

The buttons on the receiver- and microphone boards can either be pressed to turn the boards ON/OFF or start a pairing procedure.

See [Table 3](#). and section [4.1 on page 11](#).

Button	Description
Short press <sup>a</sup>	Turn ON/OFF
Long press	Start pairing

a. Microphone board only

*Table 3. Button operation*

## 4.1 Pairing procedure

If you want to pair a microphone with another receiver board, or you have a receiver- or microphone board which hasn't been paired before, you will need to pair the boards. You can only pair one microphone board with a receiver board, at a time. Hold in the button on each board until the LEDs on each board blink rapidly (meaning faster than the normal no-link blinking), then let go.

The lights should stop blinking rapidly once the boards are paired. Some seconds may pass as the boards reload configuration values. Repeat the procedure if you also want to pair the second microphone.

## 4.2 Programming boards

If you want to customize the nRFready Microphone, you can program the receiver- and microphone board microcontrollers using a third-party development tool. The nRFready Microphone uses a PICkit 2™ Development Programmer for in-circuit programming of the PIC16F684 microcontroller. You can use either PICkit 2™ or the PICkit3™. The development tool must be bought separately since it is not included in this kit.

The boards can be programmed in one of two ways:

- The pre-compiled HEX files for the microphones and receiver can be programmed directly by using the PICkit2™ programmer tool. None of the boards need to be supplied with external power during programming, just simply connect the programmer to the ISP header, import HEX and write to the device.
- You can also compile and program the boards directly from the MPLAB IDE. Make sure to select the correct programmer tool from the **Programmer** tab in MPLAB IDE before building the project and programming the board. Refer to the user guide for the MPLAB IDE available from <http://www.microchip.com> for further details.



Figure 3. Receiver board and microphone setup with PICkit2™

### 4.3 Compiling firmware

The project source files can be opened and compiled in MPLAB IDE. There are separate project files for the microphone and receiver board. The receiver board can be compiled as-is with no changes, but the microphone project uses the same source files for both microphones, referred to as the red microphone and the blue microphone. This means you must make a small change to one of the source files to decide which microphone firmware shall be compiled.

The **AdjustableParameters.h** defines whether the microphone project should be compiled for the red or the blue microphone:

```
#define RED_MIC //comment this to create .hex file for BLUE_MIC
```

Note that pairing information is erased during programming, so both microphones must be paired with the receiver again. Refer to section [4.1 on page 11](#) for a description of the pairing procedure.

## 5 Hardware description

This chapter contains block diagrams and a description of each board in the reference design. Refer to the product specification for the various ICs before making any changes to the design.

### 5.1 nRF2788 Microphone

The microphone board has a 3.5mm mini-jack header for a full-differential microphone input. For demonstration purposes a MP3 player can also be used. The analog signal is sampled by a 16-bit AK5700 mono ADC with a microphone amplifier and Auto Level Control (ALC). The sampled signal is fed to the nRF2460 wireless mono audio streamer that transmits the signal to the receiver board. The microphone board is powered from two AAA batteries. See [Figure 4](#). for details.

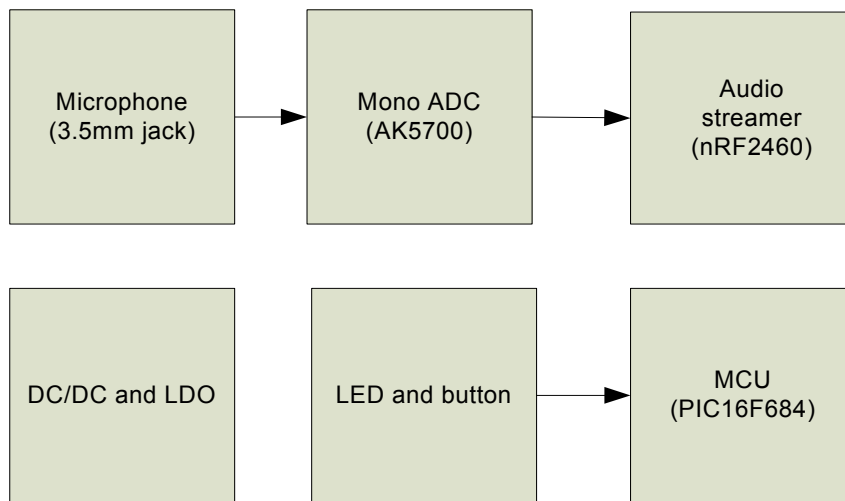

Figure 4. Block diagram of microphone board

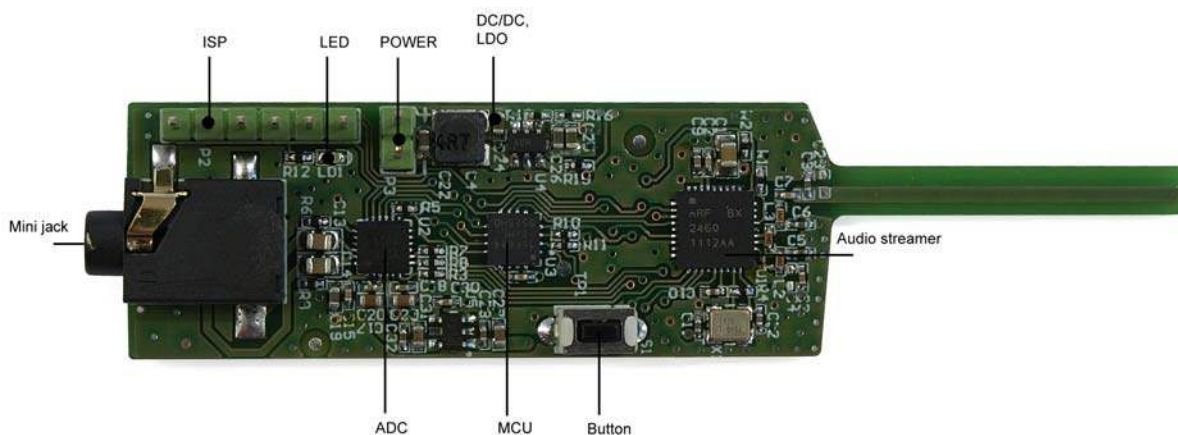

Figure 5. Annotated photograph of microphone board

## 5.2 nRF2789 Receiver

The receiver board has two nRF2460 wireless mono audio streamers to receive audio from two nRFready microphones. The digital signal is fed to two AK4430 stereo DACs which in turn output the converted analog signal to two phono outputs and an AK5374 USB ADC for USB connection to a computer. The board will enumerate as a two-channel recording device when connected to a computer. The receiver board is powered from a USB connection. See [Figure 6](#).

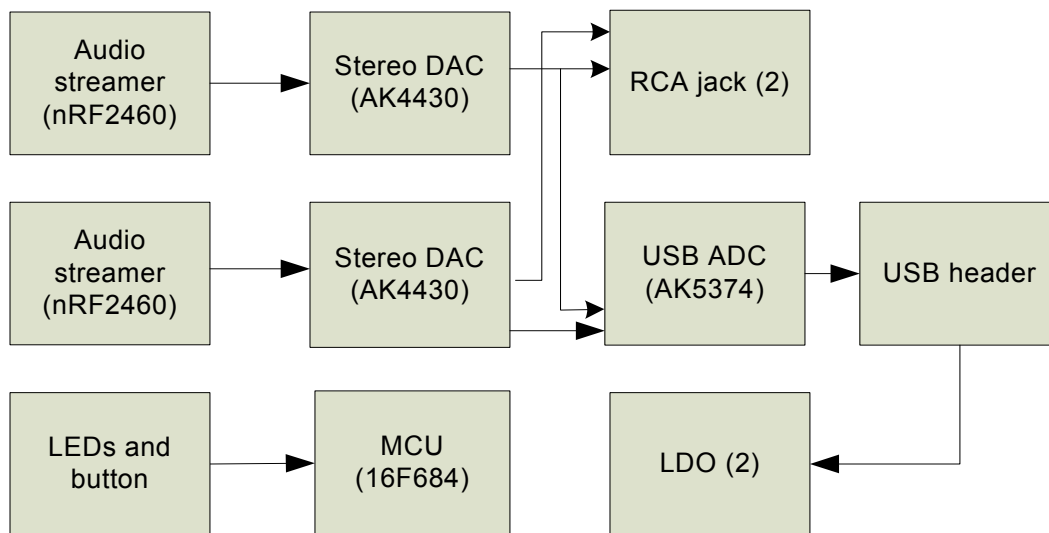

Figure 6. Block diagram of receiver board



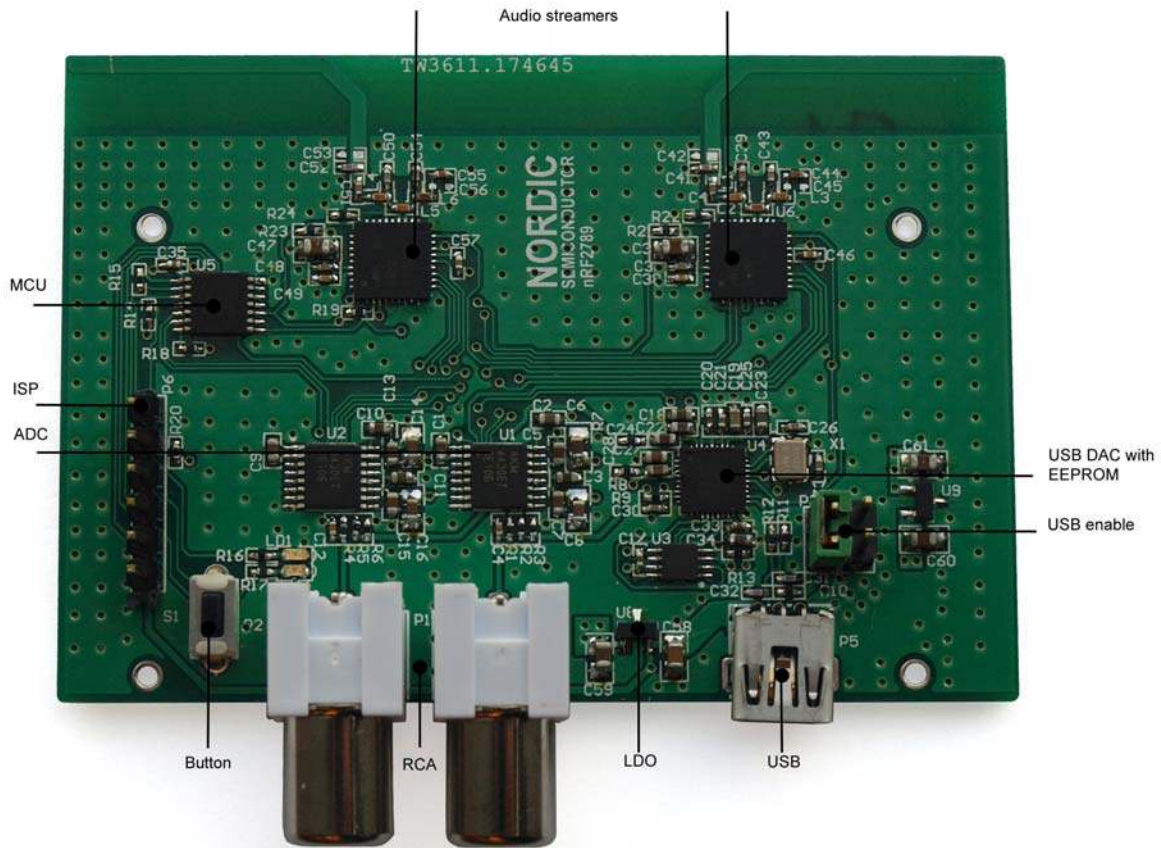

Figure 7. Annotated photograph of receiver board

### 5.3 Layout guidelines

Download and open the nRFReady Microphone design files to view the schematic, PCB layout, Bill of Materials and production files. To ensure optimal performance it is essential that you follow the schematics- and PCB layout references closely.

Refer to PCB layout and de-coupling guidelines in the various ICs' product specifications before making any changes to the design.

### 5.4 Power supply

As in all electronic design the quality of the design is not only decided by the active devices themselves, but also by how they work together. Basically, there are two very important things to look out for in an nRF2460 design:

- Noise crosstalk through the power supply
- Ground layout

The nRF2460 is a two-way, package-based radio, meaning it will constantly switch between transmit-receive-transmit-receive and so on in 3ms intervals. In these two modes, transmit and receive, the current

drawn will be different, which may give rise to voltage ripple on the power supply line. If this voltage ripple is allowed to enter the analog audio part of the design (ADC/DAC), a constant 333 Hz tone might be present in the audio output.

Hence, when nRF2460 is used in combination with ADC/DAC, the nRF2460 must be considered to belong to the digital domain. Because of this, it is very important to prevent power supply noise generated by nRF2460 (and other digital circuitry) from reaching the analog supply pins and reference voltage pins of the ADC/DAC.

On the receiver board two LDOs fed from VBUS are used to separate digital and analog power supply on the board. On the microphone board a DC/DC converter is used for the digital power supply, while the analog power supply is fed through an LDO regulator supplied from the DC/DC converter. Both designs use star-routing and sufficient decoupling to reduce the noise to a minimum.

Good ground layout is just as important as the power supply distribution strategy to ensure the best possible performance both from the nRF2460 and the ADC/DACs. In the nRFready Microphone Reference Design both boards use a PCB with two layers. All available areas on the top and bottom layers are flooded with ground plane. The top layer ground plane areas are connected to the bottom layer ground plane areas through a large number of vias. For further reference, see the nRFready Microphone PCB layout files in Altium Designer, .pdf or gerber formats.

## 5.5 Antenna

The antenna type implemented on the microphone- and receiver boards is a quarter wavelength monopole antenna printed on the PCB. The antennas on the boards are tuned to be resonant at 2.44 GHz, and the impedance of each antenna is matched to the 50Ω output of the nRF2460 device matching network with the use of a shunt capacitor to ground close to the antenna feed-point. The antennas are tuned for the given board layouts only, and without any plastic housings.

The two antennas on the receiver board were tuned with the board connected to a computer with a USB cable. The microphone board antenna was tuned with the battery holder attached to the board with double-sided tape, and with the batteries inserted.

If the microphone- and receiver board layouts are changed and/or plastic housings are added, the antennas must most probably be re-tuned. The quarter wavelength monopole type antenna can be re-tuned by adjusting the length of it and/or tuning the value of the shunt capacitor. The exact length of the antenna and the value of the shunt capacitor must be determined by measurements with a vector network analyzer.

## 5.6 Crystal oscillator

A 16 MHz crystal with a tolerance of max ±50ppm is required on both the receiver and microphone side. To synchronize the two nRF2460 devices on the receiver board it is required that they share the same 16 MHz clock. The synchronization is achieved by a 16 MHz crystal that is connected to the USB DAC, and then fed to the XC1 input of the two nRF2460s.

## 5.7 User interface

Buttons and LEDs are the user interface through which you turn ON/OFF the microphones, and pair the microphones with the receiver, see chapter [4 on page 10](#) for kit operation.

## 5.8 Programming interface

Pin	Description
1	MCLR
2	VPO
3	Ground
4	ICSPDATA
5	ICSPCLK
6	Not used/VBUS

Table 4. Pinout of ISP connector (microphone header P2 and receiver header P6)

Refer to [Figure 5. on page 13](#) and [Figure 7. on page 15](#) for the location of the in-system programming (ISP) interface on the microphone- and receiver boards, respectively.

## 5.9 RF regulation

The nRFready Microphone Reference Design has been tested on key RF parameters in a certified lab for the purpose of demonstrating compliance with ETSI 300-328, FCC CFR 47 paragraph 15.247 and Industry Canada RSS-210, Issue 8 & RSS-Gen, Issue 3. The test reports are available for download from [www.nordicsemi.com](http://www.nordicsemi.com).

## 6 Troubleshooting

I have followed the Getting Started Guide, but there is no audio. What should I do?

- Try to pair the boards again by following the procedure in section [4.1 on page 11](#).
- Try new AAA batteries
- Check the USB cable

When I unplug the MP3 player from the microphone board or pause music, a short noise can be heard. What has happened?

- The input of the microphone board is designed for a full-differential microphone to be connected. The input is powered through a 1k $\Omega$  resistor, and when the MP3 player is disconnected, the input changes the DC level, which may cause short-lasting noise.