

REVISIONS			
REV.	DESCRIPTION	DATE	APPROVED
A	INITIAL RELEASE	05/04/16	N.D.

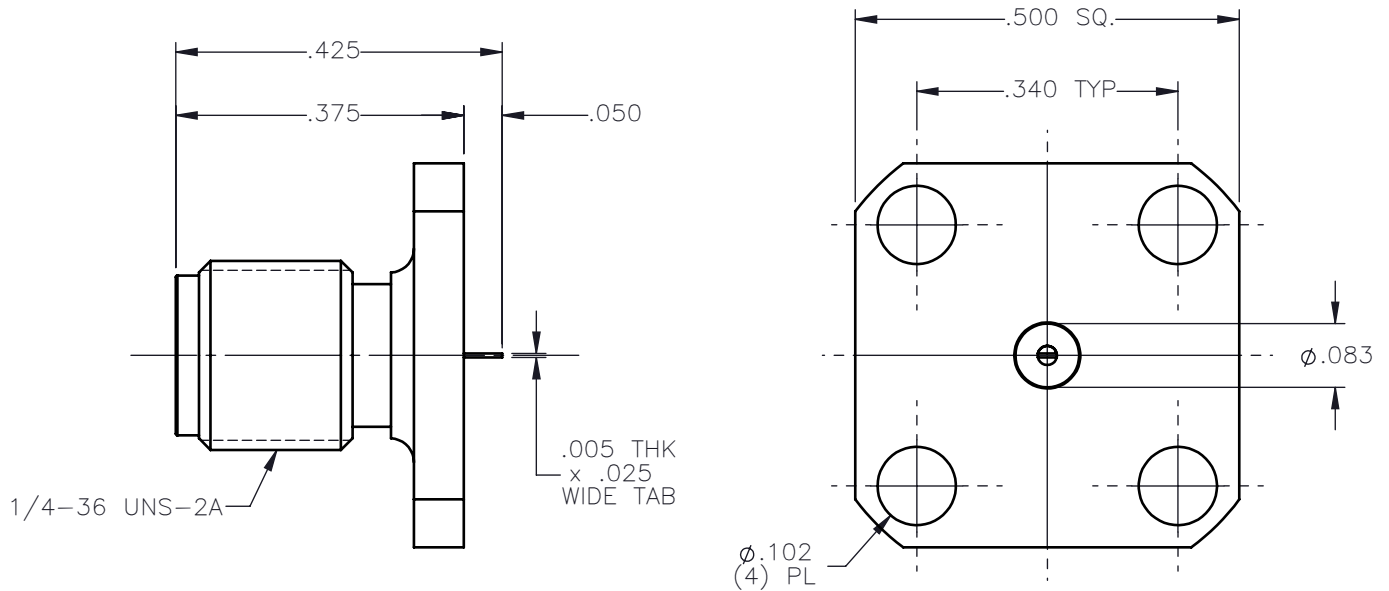



NOTES:

MATERIALS:

1. BODY = STAINLESS STEEL PER ASTM A582, ALLOY 303, CONDITION "A".
2. INSULATOR = VIRGIN WHITE TEFLON PER ASTM D1710, GRADE 1, TYPE I, CLASS "B".
3. CONTACT = BERYLLIUM COPPER PER ASTM B196, ALLOY C17300, TEMPER TD04.

FINISHES:

1. BODY = GOLD PLATE PER ASTM B488-11, TYPE II, 30µin MIN, GRADE C, OVER 50 TO 100µin STRESS FREE NICKEL PER AMS-QQ-N-290.
2. CONTACT = GOLD PLATE PER ASTM B488-11, TYPE II, 50µin MIN, GRADE C, OVER 100 TO 200µin STRESS FREE SULFAMATE NICKEL PER AMS-QQ-N-290.

UNLESS OTHERWISE SPECIFIED DIMENSIONS ARE IN INCHES TOLERANCES ON	DWN:	DATE	 Property of Radiall This document cannot be reproduced or communicated to a third party without prior written permission of RADIALL.			
	N.D.	05/04/16				
DECIMAL	ANGLE	CHKD:	DATE	SMA STRAIGHT JACK 4 HOLE FLANGE MOUNT TAB CONTACT		
		D.N.	05/04/16			
		APVD:	DATE			
		J.M.	05/04/16			
REFERENCE:	MATERIALS AND FINISHES:		SIZE	FSCM NO.	DWG NO.	REV
ORIGINATED: N.D. DATE: 05/04/16	SEE NOTES		A	19505	9114-1113-000	A
			SCALE 4:1	THIRD ANGLE PROJECTION		SHEET 1 OF 1

9114-1113-000