



## LEDD10\_24 Series

Constant current power LED driver - Wide Input - Non-Isolated & Regulated

## LED Driver

- ⊕ SMD package, simple and convenient
- ⊕ High efficiency up to 95%
- ⊕ Short circuit protection (SCP)
- ⊕ Ultra wide range voltage input (5.5-48VDC)
- ⊕ With large capacitive loads (1000µF)
- ⊕ AC-DC, EMC recommended circuit
- ⊕ PWM dimming & analogue dimming
- ⊕ Low ripple & noise (<100mV)
- ⊕ RoHS and UL compliance

The LEDD10\_24 is a series of step-down constant current source designed for driving high power LEDs. With high efficiency, wide input voltage range, high-temperature environment, functional and so on. Contains a PWM dimming, analogue dimming and remote shutdown capabilities.

It is widely used in LED illumination areas such as backlight and 12V, 24V, 36V automotive lighting, landscape lighting, special lighting controls, commercial lighting, street lighting, home lighting and other lighting systems.



Specifications					
Item	Test condition	Min	Typ	Max	Units
Utmost input voltage	≤10 seconds	5		55	VDC
Recommended input voltage		5.5	24	48	VDC
Min. Input-output Voltage Drop	Input voltage range	2		4	VDC
Input filter	Capacitor				
Internal power dissipation	Vin=24V, 5LEDS			0.7	W
Output voltage range	Vin=48V	3.3		36	VDC
Output power	• Io: 300mA • Io: 350mA • Io: 500mA • Io: 600mA • Io: 700mA			10.8 12.6 18 21.6 25.2	W W W W W
Output current accuracy	• Io: 300-600mA • Io: 700mA		±3 ±5	±5 ±7	% %
Output current stability	Vin=48V, Vo=3.3V~36V		±3	±5	%
Temperature coefficient	-40°C to +71°C			0.015	%/°C
Ripple & Noise	20MHz bandwidth (Vin=48V, 1-10 LEDs)			100	mV
Over temperature protection	Self recovery after cooling				
Short circuit protection	Continuous, automatic recovery				
Operating temperature range	• 300mA/350mA • 500mA/600mA/ 700mA	-40 -40		85 71	°C °C
Storage temperature		-55		125	°C
Maximum case temperature				100	°C
Lead temperature	1.5mm away from the casing, 10 seconds			300	°C
Humidity				95	%
Operating frequency range		550	645	750	kHz
MTBF	MIL-HDBK-217F(+25°C)			1,000,000	Hours
Case Material	Epoxy Resin (UL94-V0)				
Dimensions				22,8 * 10,2 * 9	mm
Weight				4.3	g

### PWM dimming and ON/OFF control (leave open if not used)

Item	Test condition	Min	Typ	Max	Units
Remote ON/OFF	• ON • OFF (shutdown)			Open or 2.8V<Vc<6V Vc<0.6V	
Turn-off-mode static input current	Vin=24V, Vc <0.6V		400		µA
Isink	Vc=5V, Vin=24V, 5LEDS			1	mA
Isourse	Vc<0.6V, Vin=24V, 5LEDS		1		mA
PWM frequency	refer to PWM dimming control			200	Hz

### Analogue dimming (leave open if not used)

Item	Test condition	Min	Typ	Max	Units
Input voltage range	Vin=5.5-48V			0-15V	
Output current range	Vin=5.5-48V			0%-100%	
Control voltage range	• Full on • Full off			0.2V±50mV 4.5V±200mV	
Driving current	Vc=5V			0.2mA (max)	

### EMC specifications

EMI	Conducted disturbance	EN55015 power port/CISPR22 CLASS B*			
EMI	Radiated Emission	EN55015 /CISPR22 CLASS B*			
EMS	Electrostatic Discharge	IEC/EN61000-4-2 Contact ±2KV		perf. Criteria B*	
EMS	Radiation Immunity	IEC/EN61000-4-3	10V/m	perf. Criteria A	
EMS	EFT	IEC/EN61000-4-4	±1KV	perf. Criteria B*	
EMS	Surge Immunity	IEC/EN61000-4-5	±1KV	perf. Criteria B*	
EMS	CS	IEC/EN61000-4-6	3 Vr.m.s	perf. Criteria A	

\* Refer to EMC solution-recommended circuit

**Example:**  
LEDD10\_24-300  
LED= Series D10= DIP10; yy= 24VDC nominal; 300= 0,3A

## LEDD10\_24 Series

Constant current power LED driver - Wide Input - Non-Isolated & Regulated

Part Number	Input Voltage [VDC] Nominal (Range)	Input current [mA, typ., 5 LEDs]	Output Voltage [VDC]	Output Current [mA]	Max. capacitive load [μF]	Efficiency [% , typ]
LEDD10_24-300	24 (5.5-48)	237	3.3-36	0-300	1000	95
LEDD10_24-350	24 (5.5-48)	276	3.3-36	0-350	1000	95
LEDD10_24-500	24 (5.5-48)	395	3.3-36	0-500	1000	95
LEDD10_24-600	24 (5.5-48)	474	3.3-36	0-600	1000	95
LEDD10_24-700	24 (5.5-48)	553	3.3-36	0-700	1000	95

## Input vs. Output

Input voltage	Output voltage range [VDC]	Output constant current [mA]	Output power [W, max]
48	3.3-36.0	300	10.80
36	3.3-32.0	300	9.60
24	3.3-21.0	300	6.30
20	3.3-17.0	300	5.10
15	3.3-13.2	300	3.96
12	3.3-10.0	300	3.00
5.5	3.3-4.0	300	1.20

Input voltage	Output voltage range [VDC]	Output constant current [mA]	Output power [W, max]
48	3.3-36.0	600	21.60
36	3.3-32.0	600	19.20
24	3.3-21.0	600	12.60
20	3.3-17.0	600	10.20
15	3.3-13.2	600	7.92
12	3.3-10.0	600	6.00
5.5	3.3-4.0	600	2.40

Input voltage	Output voltage range [VDC]	Output constant current [mA]	Output power [W, max]
48	3.3-36.0	350	12.60
36	3.3-32.0	350	11.20
24	3.3-21.0	350	7.35
20	3.3-17.0	350	5.95
15	3.3-13.2	350	4.62
12	3.3-10.0	350	3.50
5.5	3.3-4.0	350	1.40

Input voltage	Output voltage range [VDC]	Output constant current [mA]	Output power [W, max]
48	3.3-36.0	700	25.20
36	3.3-32.0	700	22.40
24	3.3-21.0	700	14.70
20	3.3-17.0	700	11.90
15	3.3-13.2	700	9.24
12	3.3-10.0	700	7.00
5.5	3.3-4.0	700	2.80

Input voltage	Output voltage range [VDC]	Output constant current [mA]	Output power [W, max]
48	3.3-36.0	500	18.00
36	3.3-32.0	500	16.00
24	3.3-21.0	500	10.50
20	3.3-17.0	500	8.50
15	3.3-13.2	500	6.60
12	3.3-10.0	500	5.00
5.5	3.3-4.0	500	2.00

## Typical application circuits

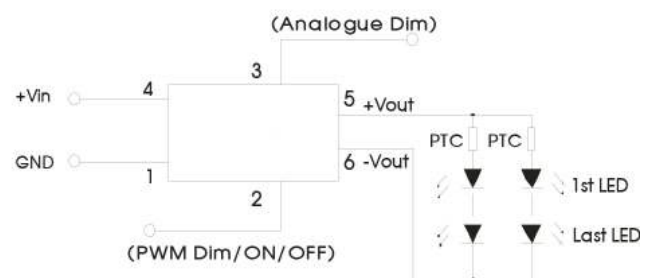
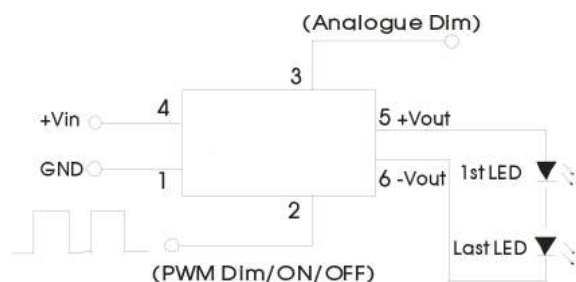

If it is necessary to protect LED in actual application, you could connect a PTC to the input of every channel or all channels, as shown in Recommended AC input circuit.

Note: The negative output terminal can't connect GND, or the module may be damaged.

# LEDD10\_24 Series

Constant current power LED driver - Wide Input - Non-Isolated & Regulated

## Recommended AC input circuit

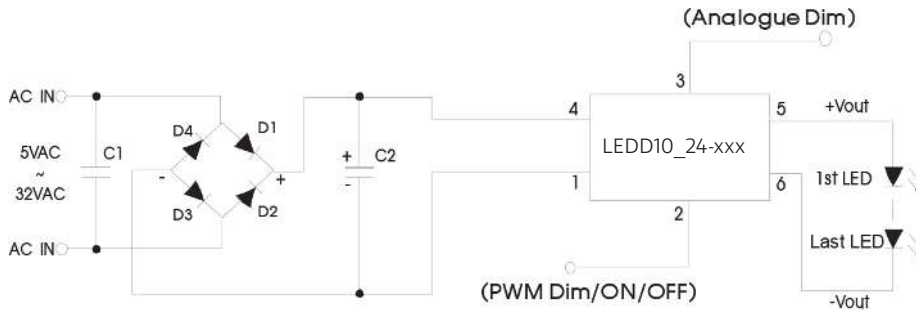

Components	Specifications
C1	X1 Safety capacitor, 0.1µF /300VAC (QIYA)
C2	100µF /63V Electrolytic capacitor, 10×16 (Flat surface) NCC
D1, D2, D3, D4	Rectifier diode 1N4007 1A/1000V DO-41(PANJIT)

## EMC solution-recommended circuit

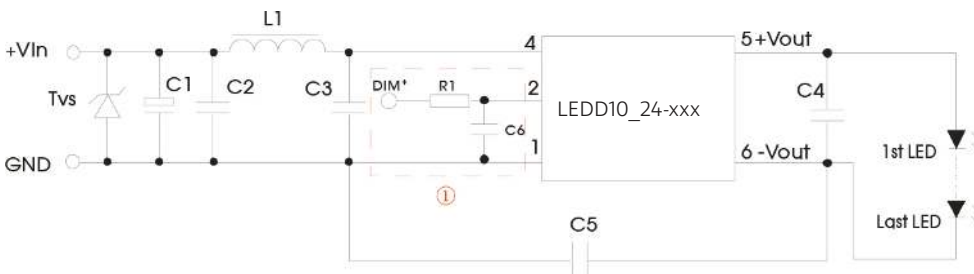

Components	Specifications
Tvs	SMC51A,1500W (ON)
L1	CD53-82µH (CEAIYA)
C1	470µF/100V (NCC)
C2	225K/50V 1210 X7R (TORCH)
C3	104K/50V 0805 X7R (TORCH)
C4	105K/50V 1210 X7R (TORCH)
C5	102K/2000V 1210 (TDK) choose or no)
C6	470pF/100V 0805 (TORCH)
R1	680Ω 0805 (can be replaced by inductance or magnetic bead)

Note: Add circuit ① may let the ESD level of PWM-control pin reach to ±6KV.

## PWM dimming control

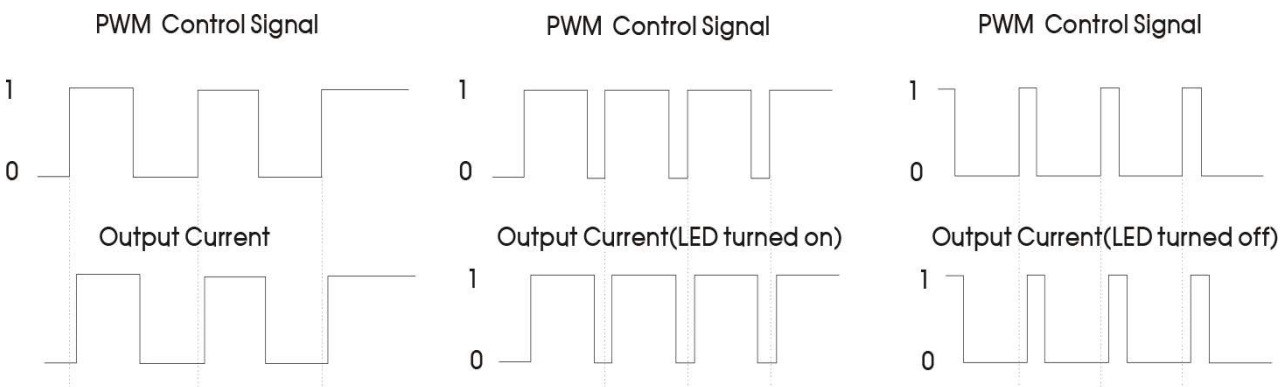

For PWM dimming signals with a certain frequency, the output current of the driver is related to the duty ratio of PWM signal. Refer to the formula for the calculation method:

$$I_{o\_set} = \frac{(DT-0.8)}{T} I_{o\_norm}$$

**Note:** The formula is for reference only; and deviation of output current may exist due to various loads. The min. conducted time of PWM signal shall not be less than 0.8ms, or the product will be in abnormal operation; in case of low voice from the driver during PWM dimming, it is normal since the PWM dimming frequency is within the auditory frequency range of human ears (20Hz-20KHz in general). To prevent seeing flash of the LED by human eyes, it is suggested to set the PWM dimming frequency between 100-200Hz.

## LEDD10\_24 Series

Constant current power LED driver - Wide Input - Non-Isolated & Regulated

### PWM curves

Output current VS PWM dimming frequency (D=50%)

PWM curve (Vin=24V, 5LEDs):

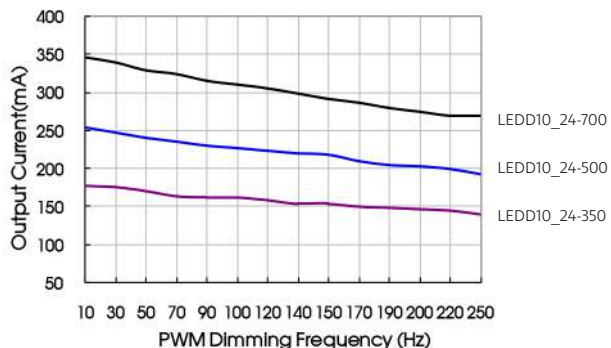

Output current VS Dimming duty ratio (f=200Hz)

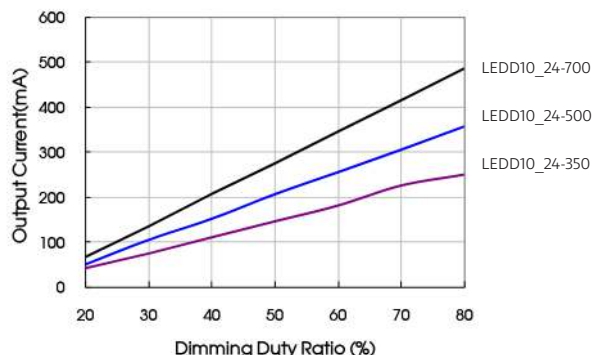

### Analogue dimming control and application sample

Analogue dimming circuit

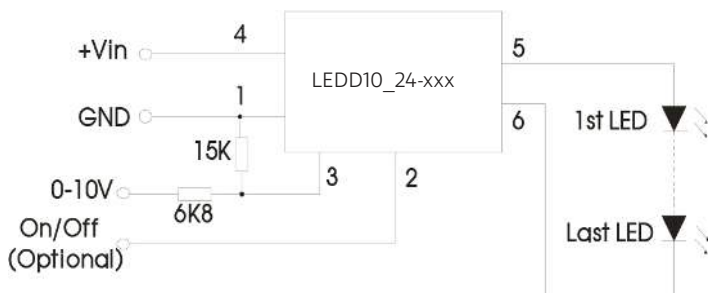

Analogue input voltage and output current

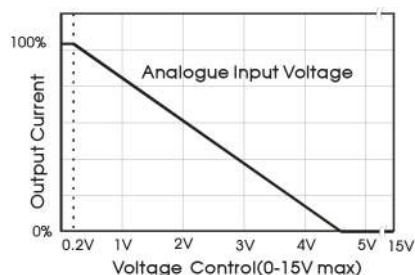

Note:

The voltage drop of all LEDs in the datasheet is 3.3-3.8V during actual application, the number of LEDs can be confirmed based on the actual voltage drop and output voltage of LEDs.

This product does not support hot-Plug use.

### Typical characteristics

Temperature Derating Curve

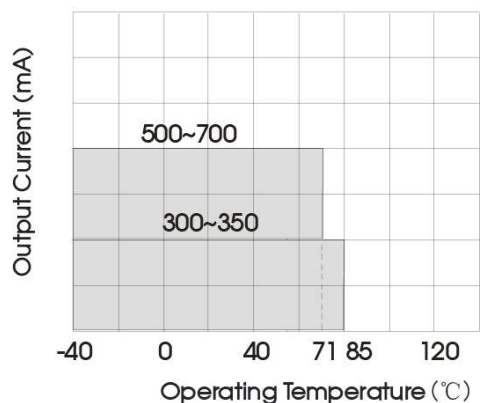

## LEDD10\_24 Series

Constant current power LED driver - Wide Input - Non-Isolated & Regulated

### Efficiency

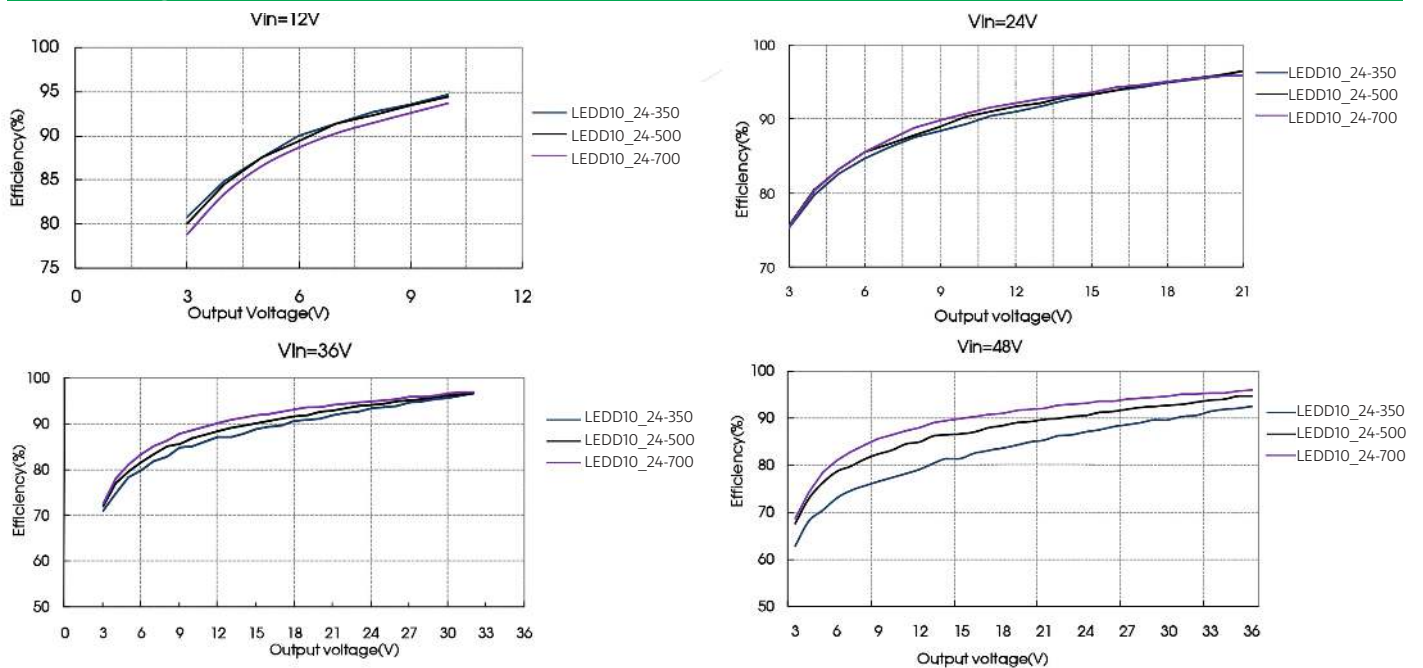

### Mechanical dimensions and footprint

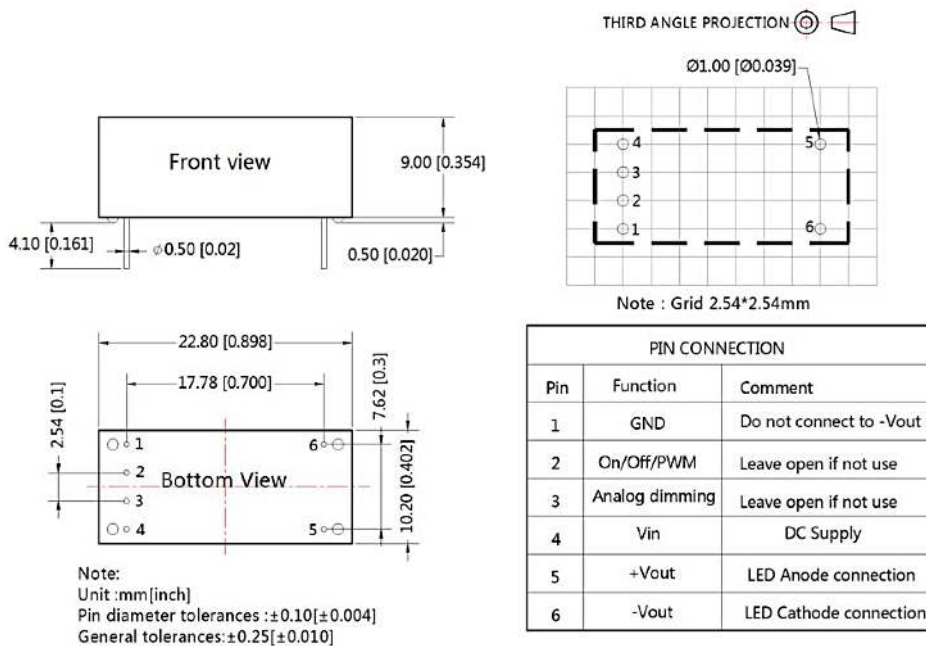

### Tube packing dimensions

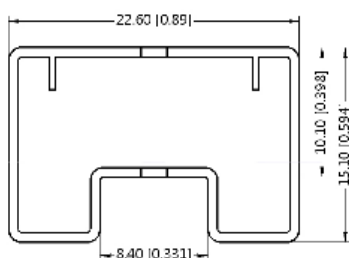

**Note:**

1. If the product is not operated within the required load range, the product performance cannot be guaranteed to comply with all parameters in the datasheet;
2. The maximum capacitive load offered were tested at nominal input voltage and full load;
3. Unless otherwise specified, parameters in this datasheet were measured under the conditions of Ta=25°C, humidity<75% with nominal input voltage and rated output load;
4. All index testing methods are based on our Company's corporate standards;
5. We can provide product customization service;
6. Specifications are subject to change without prior notice.