

THIS DRAWING IS UNPUBLISHED. RELEASED FOR PUBLICATION .19
 (C) COPYRIGHT 19 BY AMP INCORPORATED. ALL RIGHTS RESERVED.

LOC	DIST	REVISIONS					
		P	LTR	DESCRIPTION	DATE	DWN	APVD
CE	16		K	REV PER 0A00-0290-01	19OCT01	DDE	5B

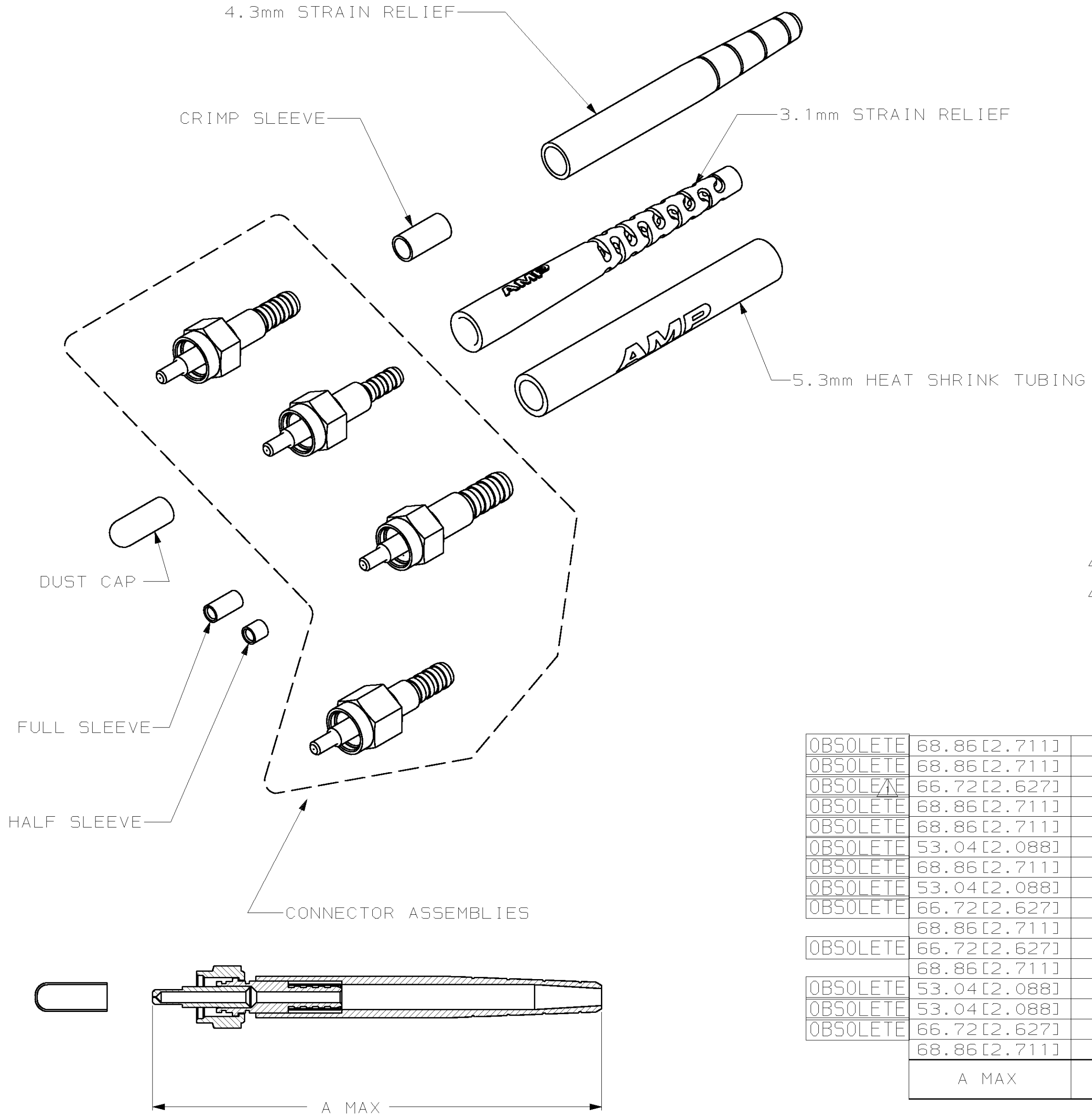

- 1 BULK PACKAGED 50 PER UNIT.
- 2 PACKAGE MUST BE MARKED "KANNegiETER CODE CGV 0103"
- 3 MATERIAL
 - a) BODY: BRASS
 - b) FERRULE: STAINLESS STEEL
 - c) NUT: BRASS
 - d) CRIMP SLEEVE: BRASS
 - e) DUST CAP: VINYL, COLOR, RED
 - f) HALF & FULL SLEEVE: DELRIN, COLOR, WHITE
- 4 MATERIAL
 - a) BODY: STAINLESS STEEL
 - b) FERRULE: STAINLESS STEEL
 - c) NUT: BRASS
 - d) CRIMP SLEEVE: BRASS
 - e) DUST CAP: VINYL, COLOR, RED
 - f) HALF & FULL SLEEVE: DELRIN, COLOR, WHITE
- 5 FINISH
 - a) BODY, NUT, CRIMP SLEEVE: NICKEL PLATE
- 6 FINISH
 - a) NUT, CRIMP SLEEVE: NICKEL PLATE
- 7 3.1mm STRAIN RELIEF: THERMOPLASTIC ELASTOMER, CLR, BLACK
- 8 4.1mm STRAIN RELIEF: VINYL, COLOR, BLACK
- 9 5.3mm HEAT SHRINK TUBING: POLYOLEFIN, COLOR, BLACK

OBSOLETE	68.86 [2.711]	7	436µm	3.1mm MAX	5	3	2-504014-5
OBSOLETE	68.86 [2.711]	7	229µm	3.1mm MAX	6	4	2-504014-4
OBSOLETE	66.72 [2.627]	8	140µm	4.3mm MAX	5	3	2-504014-3
OBSOLETE	68.86 [2.711]	7	240µm	3.1mm MAX	5	3	2-504024-1
OBSOLETE	68.86 [2.711]	7	600µm	3.1mm MAX	5	3	2-504014-0
OBSOLETE	53.04 [2.088]	9	240µm	5.3mm MAX	5	3	1-504014-9
OBSOLETE	68.86 [2.711]	7	140µm	3.1mm MAX	6	4	1-504014-4
OBSOLETE	53.04 [2.088]	9	140µm	5.3mm MAX	5	3	1-504014-2
OBSOLETE	66.72 [2.627]	8	140µm	4.3mm MAX	5	3	1-504014-1
	68.86 [2.711]	7	140µm	3.1mm MAX	5	3	1-504014-0
OBSOLETE	66.72 [2.627]	8	125µm	4.3mm MAX	6	4	504014-6
	68.86 [2.711]	7	125µm	3.1mm MAX	6	4	504014-5
OBSOLETE	53.04 [2.088]	9	125µm	5.3mm MAX	5	3	504014-4
OBSOLETE	53.04 [2.088]	9	125µm	5.3mm MAX	5	3	504014-3
OBSOLETE	66.72 [2.627]	8	125µm	4.3mm MAX	5	3	504014-2
OBSOLETE	68.86 [2.711]	7	125µm	3.1mm MAX	5	3	504014-1
A MAX	BOOT	HOLE SIZE	CABLE SIZE	FINISH	MATERIAL	PART NUMBER	

THIS DRAWING IS A CONTROLLED DOCUMENT.

DWN: R.HILEMAN 9-3-92
 CHK: P.YEAGER 9-28-02
 APVD: S.BUCHTER 9-28-02

AMP AMP Incorporated
 Harrisburg, PA 17105-3608

906 CONNECTOR KIT

SIZE: A2 CAGE CODE: 00779 DRAWING NO: C-504014 RESTRICTED TO: -

MATERIAL: SEE TABLE FINISH: SEE TABLE WEIGHT: - SCALE: NTS SHEET: 1 OF 2 REV: K

THIS DRAWING IS UNPUBLISHED. RELEASED FOR PUBLICATION, 19 .
 (C) COPYRIGHT 19 BY AMP INCORPORATED, ALL RIGHTS RESERVED.

LOC	DIST	REVISIONS					
CE	16	P	LTR	DESCRIPTION	DATE	DWN	APVD
		K		SEE SHT 1	-	-	-

OBSOLETE	68.86 [2.711]	△	336µm	3.1mm MAX	△	△	4-504014-6
OBSOLETE	68.86 [2.711]	△	200µm	3.1mm MAX	△	△	4-504014-5
OBSOLETE	68.86 [2.711]	△	200µm	3.1mm MAX	△	△	4-504014-4
OBSOLETE	68.86 [2.711]	△	.039 in	3.1mm MAX	△	△	4-504014-2
OBSOLETE	66.72 [2.627]	△	231µm	4.3mm MAX	△	△	4-504014-1
OBSOLETE	68.86 [2.711]	△	125µm	3.1mm MAX	△	△	4-504014-0
OBSOLETE	68.86 [2.711]	△	240µm	3.1mm MAX	△	△	3-504014-7
OBSOLETE	68.86 [2.711]	△	470µm	3.1mm MAX	△	△	3-504014-6
OBSOLETE	68.86 [2.711]	△	250µm	3.1mm MAX	△	△	3-504014-5
OBSOLETE	68.86 [2.711]	△	280µm	3.1mm MAX	△	△	3-504014-3
OBSOLETE	68.86 [2.711]	△	500µm	3.1mm MAX	△	△	3-504014-2
OBSOLETE	68.86 [2.711]	△	140µm	3.1mm MAX	△	△	3-504014-1
OBSOLETE	68.86 [2.711]	△	250µm	3.1mm MAX	△	△	3-504014-0
OBSOLETE	68.86 [2.711]	△	125µm	3.1mm MAX	△	△	2-504014-8
OBSOLETE	68.86 [2.711]	△	145µm	3.1mm MAX	△	△	2-504014-7
OBSOLETE	68.86 [2.711]	△	231µm	3.1mm MAX	△	△	2-504014-6
	A MAX	BOOT	HOLE SIZE	CABLE SIZE	FINISH	MATERIAL	PART NUMBER

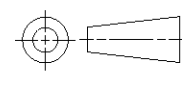
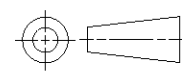
THIS DRAWING IS A CONTROLLED DOCUMENT.		DWN	R.HILEMAN	9-3-92	 AMP Incorporated Harrisburg, PA 17105-3608
DIMENSIONS: mm [INCHES]		CHK	P.YEAGER	9-28-92	
		APVD	S.BUCHTER	9-28-92	
TOLERANCES UNLESS OTHERWISE SPECIFIED: 0 PLC ±- 1 PLC ±- 2 PLC ±- 3 PLC ±- 4 PLC ±- ANGLES ±-		NAME		906 CONNECTOR KIT	
MATERIAL	SEE TABLE	FINISH	SEE TABLE	WEIGHT	-
CUSTOMER DRAWING		SCALE	NTS	SHEET	2 OF 2
		REV	K		