

REVISIONS					
P	LTR	DESCRIPTION	DATE	DWN	APVD
G		REVISED PER ECN-22-160559	07JUL2022	GSK	MD

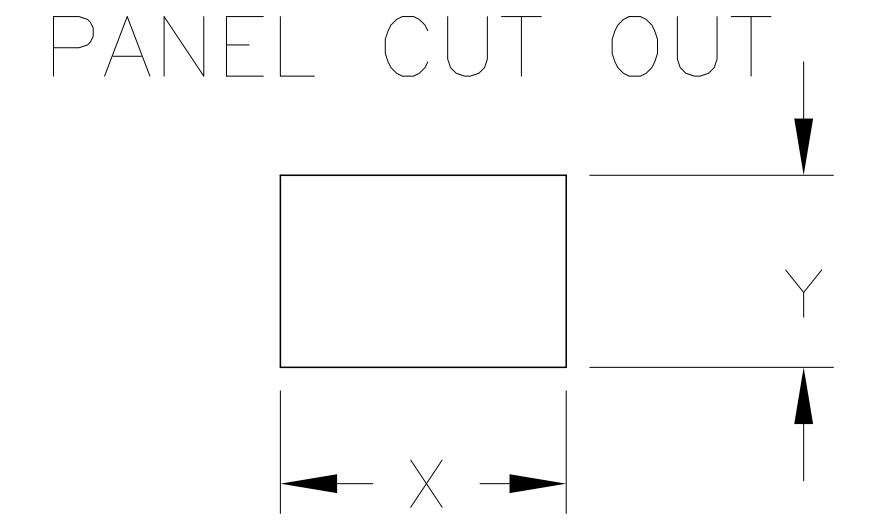

2.00-3.00	30.20	22.20
1.25-2.00	30.20	22.20
0.75-1.25	30.20	22.20
PANEL THICKNESS	X	Y

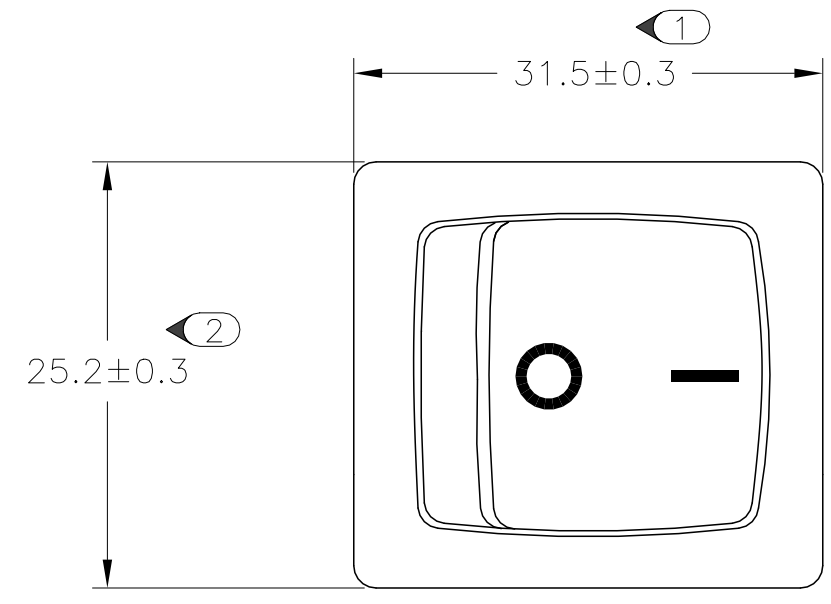
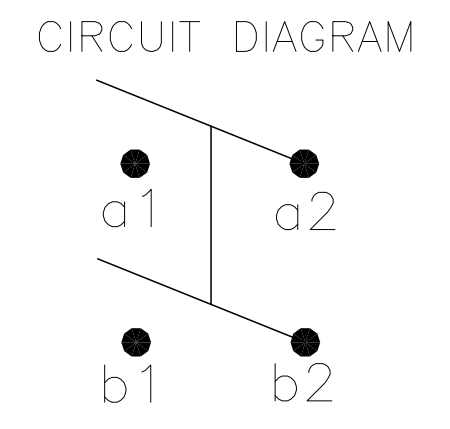
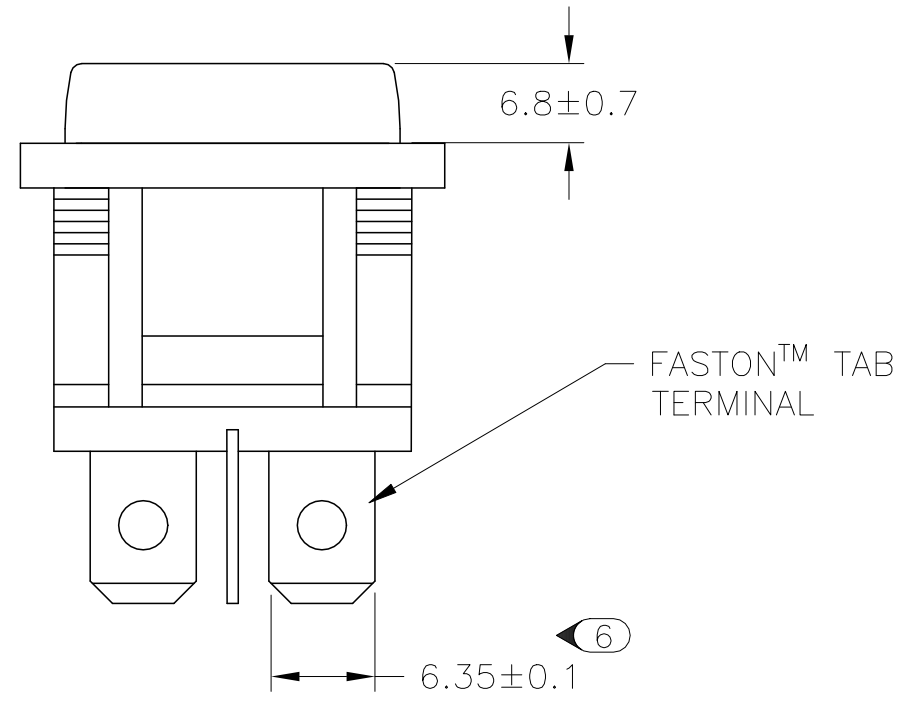
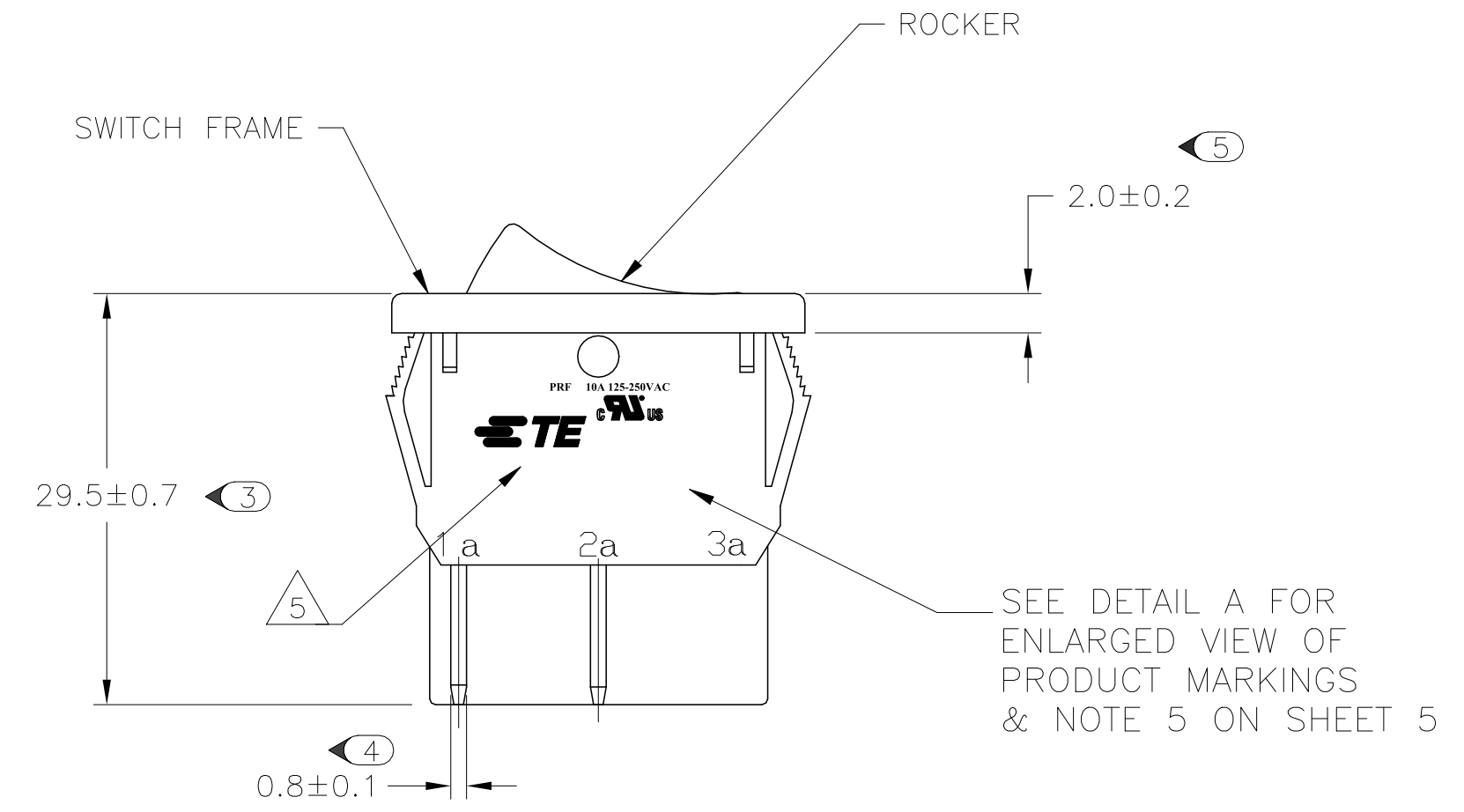

PRF 10A 125-250VAC
STE
CRL US

TYCO ELECTRONICS LOGO
 PER TEC-202-36

**PRODUCT MARKING
 DETAIL A**

6 1634201-2 SHOWN ON-OFF

THIS DRAWING IS A CONTROLLED DOCUMENT.		DWN S.SHACKSON 28JAN2003	TE Connectivity		
DIMENSIONS: MM		CHK H.KAUTZ 28JAN2003			
TOLERANCES UNLESS OTHERWISE SPECIFIED:		APVD H.KAUTZ 28JAN2003	NAME POWER ROCKER SWITCH, 30.2mm X 22.2mm PANEL SIZE, DPST, NON-ILLUMINATED		
0-PLC ± -		PRODUCT SPEC	-		
1-PLC ± 0.5		APPLICATION SPEC	-		
2-PLC ± -		NOT APPLICABLE	SIZE	CAGE CODE	DRAWING NO
3-PLC ± -		NOT APPLICABLE	A2	00779	C=1634201
4-PLC ± -	FINISH	WEIGHT	RESTRICTED TO		
ANGLES ± -	1	CUSTOMER DRAWING		-	
FINISH	2	SCALE	SHEET	REV	
		3:1	1 of 5	G	

REVISIONS					
P	LTR	DESCRIPTION	DATE	DWN	APVD
-	-	SEE SHEET 1	-	-	-

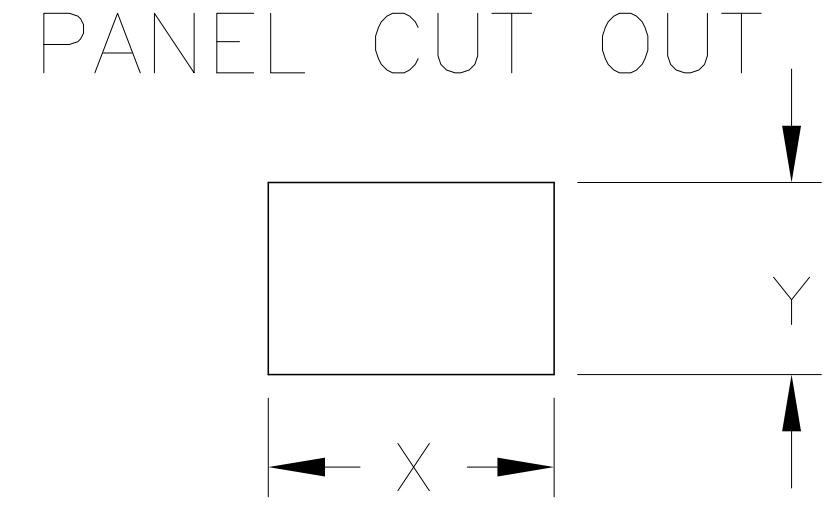
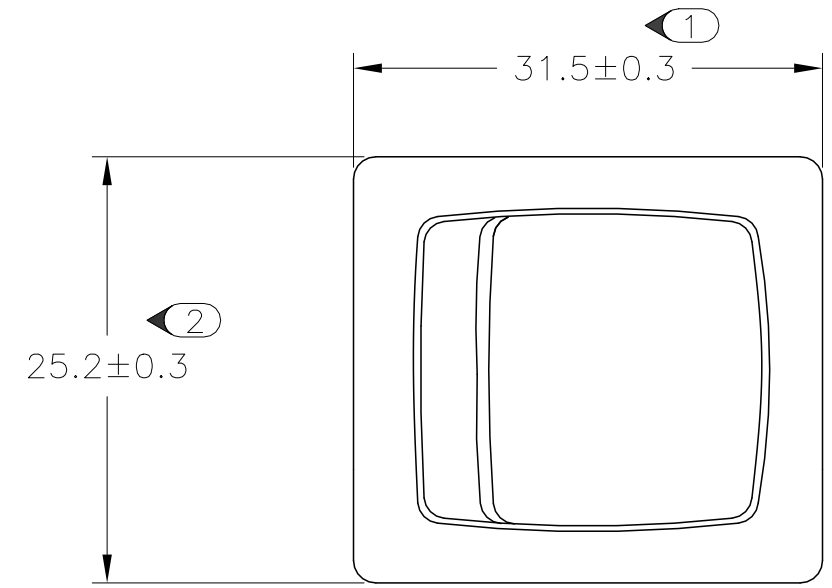

2.00-3.00	30.20	22.20
1.25-2.00	30.20	22.20
0.75-1.25	30.20	22.20
PANEL THICKNESS	X	Y

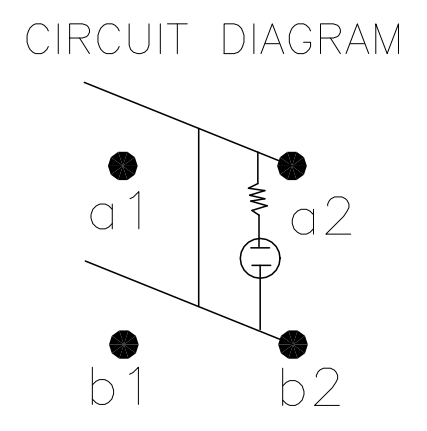
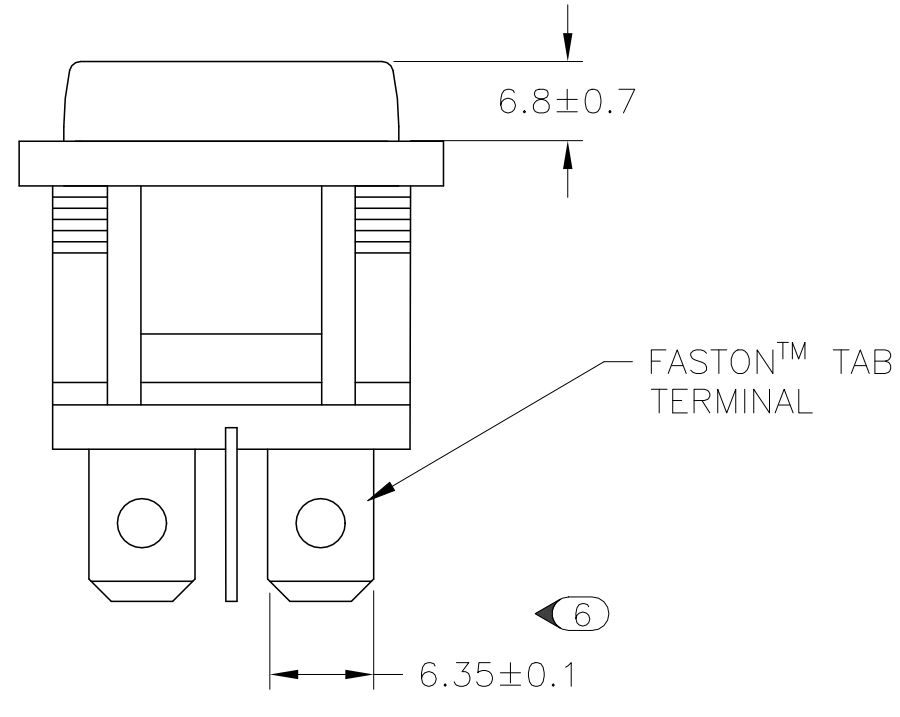
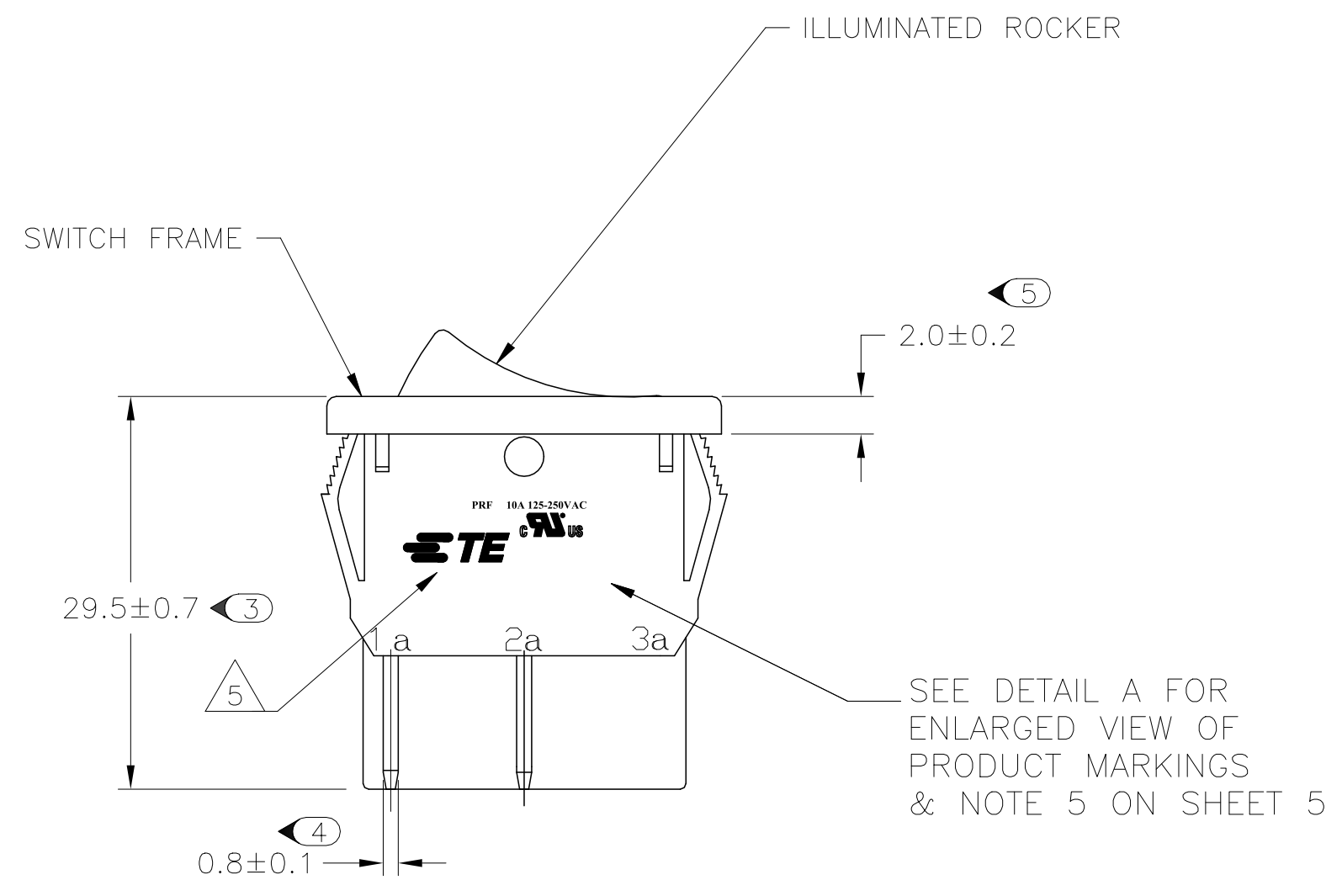

1634201-5 SHOWN ON-OFF GREEN ILLUMINATED

PRF 10A 125-250VAC

 TYCO ELECTRONICS LOGO PER TEC-202-36
PRODUCT MARKING
DETAIL A

THIS DRAWING IS A CONTROLLED DOCUMENT.		DWN S.SHACKSON 28JAN2003	 TE Connectivity	
DIMENSIONS: MM		CHK H.KAUTZ 28JAN2003		
TOLERANCES UNLESS OTHERWISE SPECIFIED:		APVD H.KAUTZ 28JAN2003	NAME POWER ROCKER SWITCH, 30.2mm X 22.2mm PANEL SIZE, DPST, NON-ILLUMINATED	
0 PLC ± -		PRODUCT SPEC	NOT APPLICABLE	
1 PLC ± 0.5		APPLICATION SPEC	NOT APPLICABLE	
2 PLC ± -				
3 PLC ± -				
4 PLC ± -				
ANGLES ± ±				
MATERIAL	FINISH	WEIGHT	SIZE A2	CAGE CODE 00779
			DRAWING NO C=1634201	RESTRICTED TO -
		CUSTOMER DRAWING	SCALE 3:1	SHEET 2 of 5
				REV G

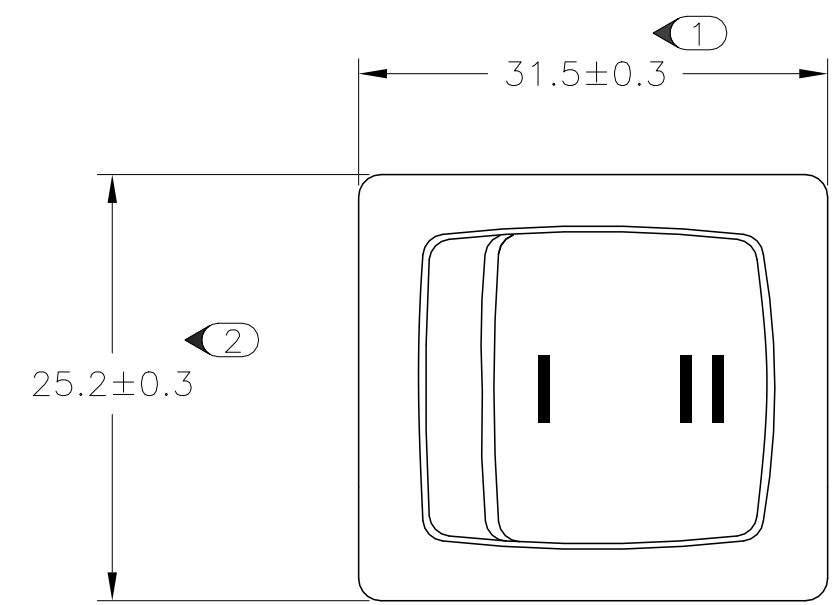
REVISIONS					
P	LTR	DESCRIPTION	DATE	DWN	APVD
-	-	SEE SHEET 1	-	-	-

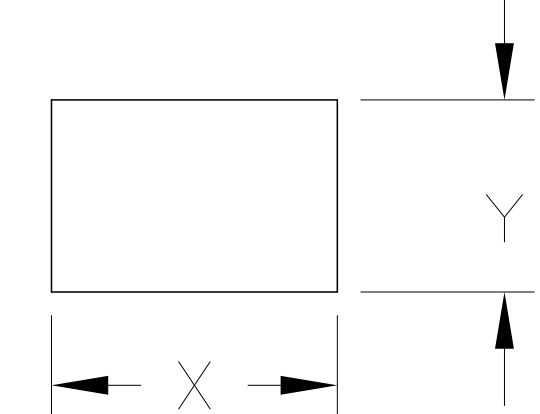

PANEL CUT OUT



2.00-3.00	30.20	22.20
1.25-2.00	30.20	22.20
0.75-1.25	30.20	22.20
PANEL THICKNESS	X	Y

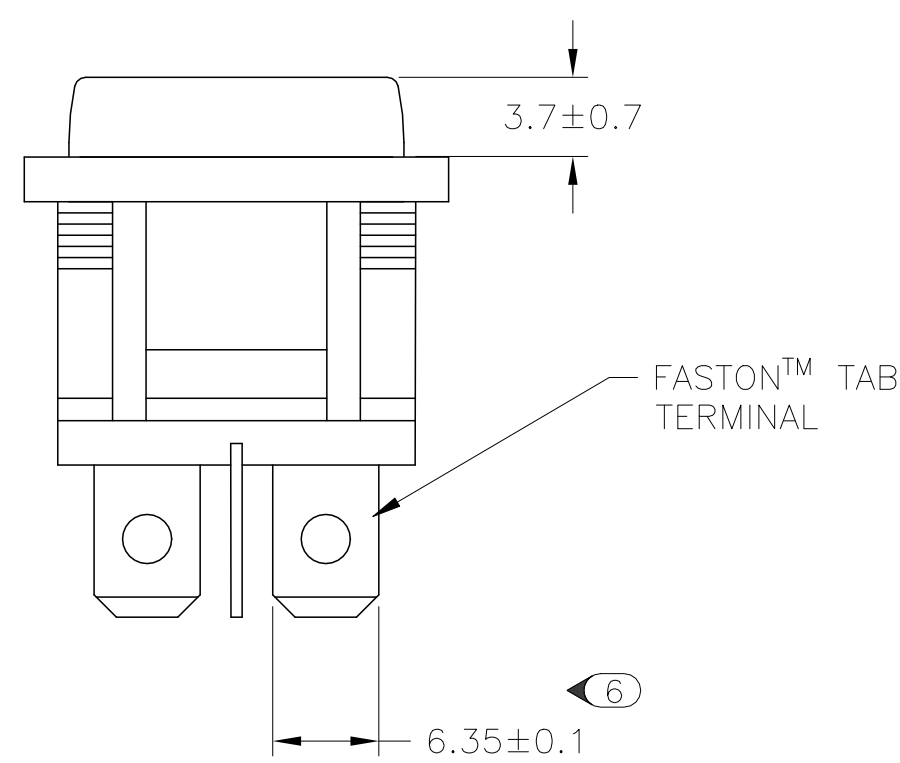
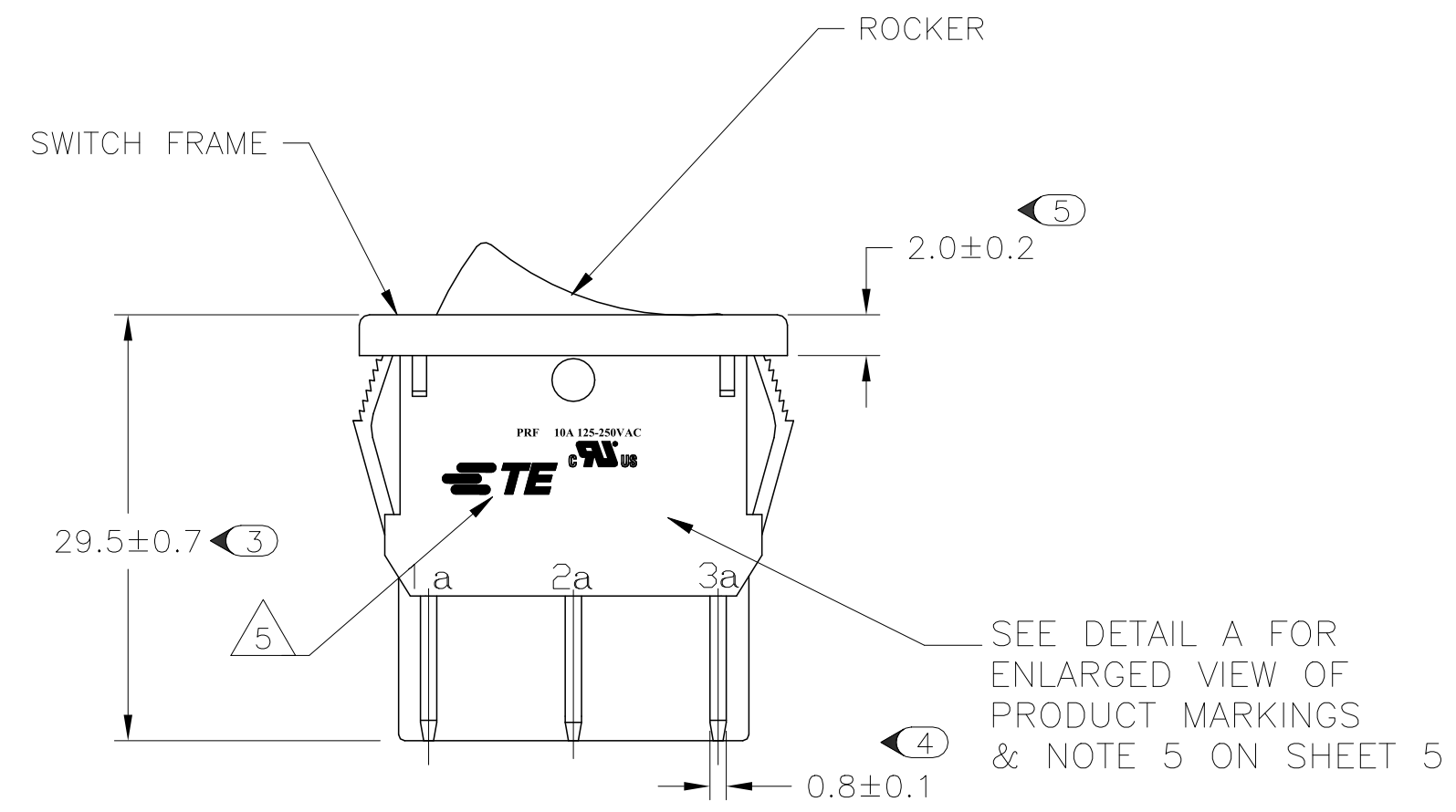

CIRCUIT DIAGRAM

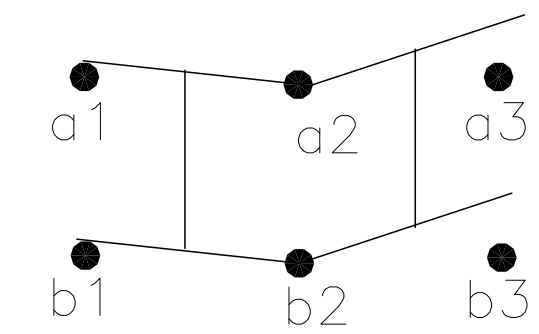

PRF 10A 125-250VAC

TYCO ELECTRONICS LOGO
 PER TEC-202-36

**PRODUCT MARKING
 DETAIL A**

OBSOLETE
 1634201-8 SHOWN ON-ON

THIS DRAWING IS A CONTROLLED DOCUMENT.		DWN S.SHACKSON 28JAN2003	TE Connectivity NAME POWER ROCKER SWITCH, 30.2mm X 22.2mm PANEL SIZE, DPST, NON-ILLUMINATED		
DIMENSIONS: MM		CHK H.KAUTZ 28JAN2003			
TOLERANCES UNLESS OTHERWISE SPECIFIED:		APVD H.KAUTZ 28JAN2003	PRODUCT SPEC	SIZE	RESTRICTED TO
0 PLC	± -	NOT APPLICABLE	APPLICATION SPEC	A2	-
1 PLC	± 0.5	NOT APPLICABLE	NOT APPLICABLE	00779	-
2 PLC	± -	NOT APPLICABLE	NOT APPLICABLE	C=1634201	-
3 PLC	± -	NOT APPLICABLE	NOT APPLICABLE	SCALE	SHEET
4 PLC	± -	NOT APPLICABLE	NOT APPLICABLE	3:1	3 of 5
ANGLES	± -	NOT APPLICABLE	NOT APPLICABLE	REV	G
MATERIAL	FINISH	WEIGHT	CUSTOMER DRAWING		

REVISIONS					
P	LTR	DESCRIPTION	DATE	DWN	APVD
-	-	SEE SHEET 1	-	-	-

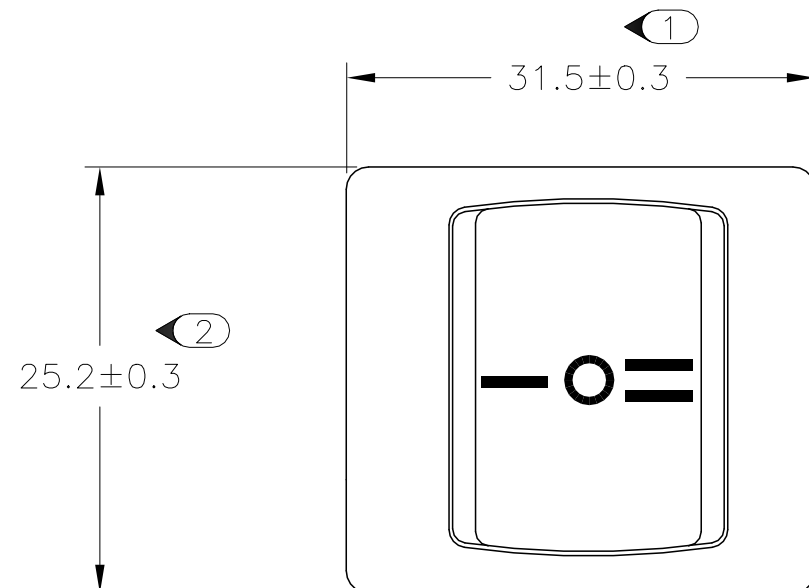

PANEL CUT OUT

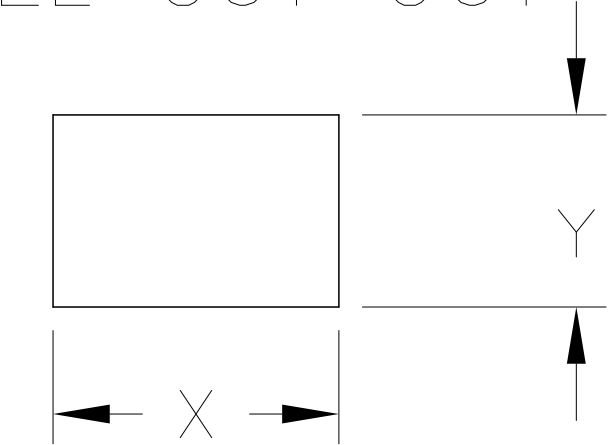

2.00-3.00	30.20	22.20
1.25-2.00	30.20	22.20
0.75-1.25	30.20	22.20
PANEL THICKNESS	X	Y

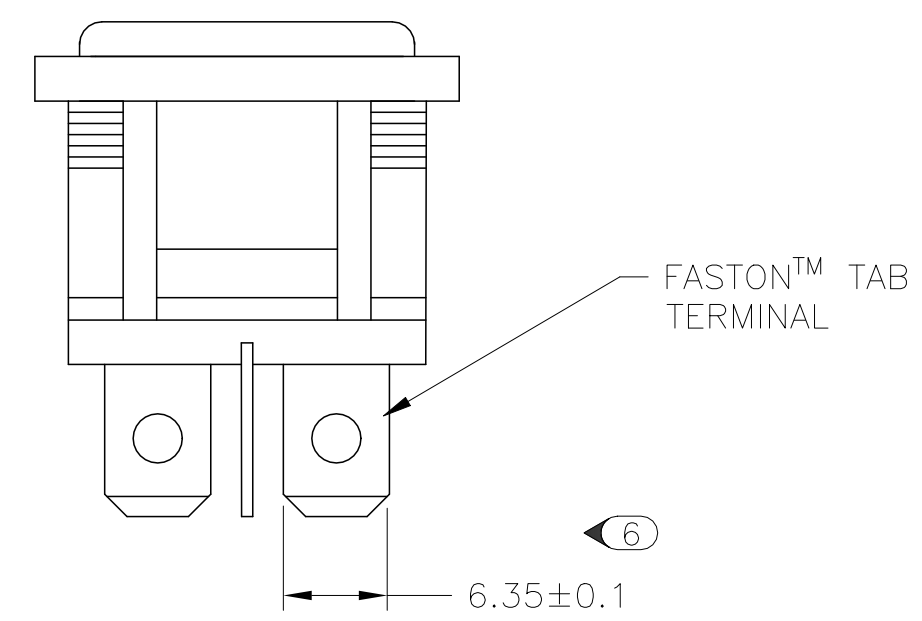
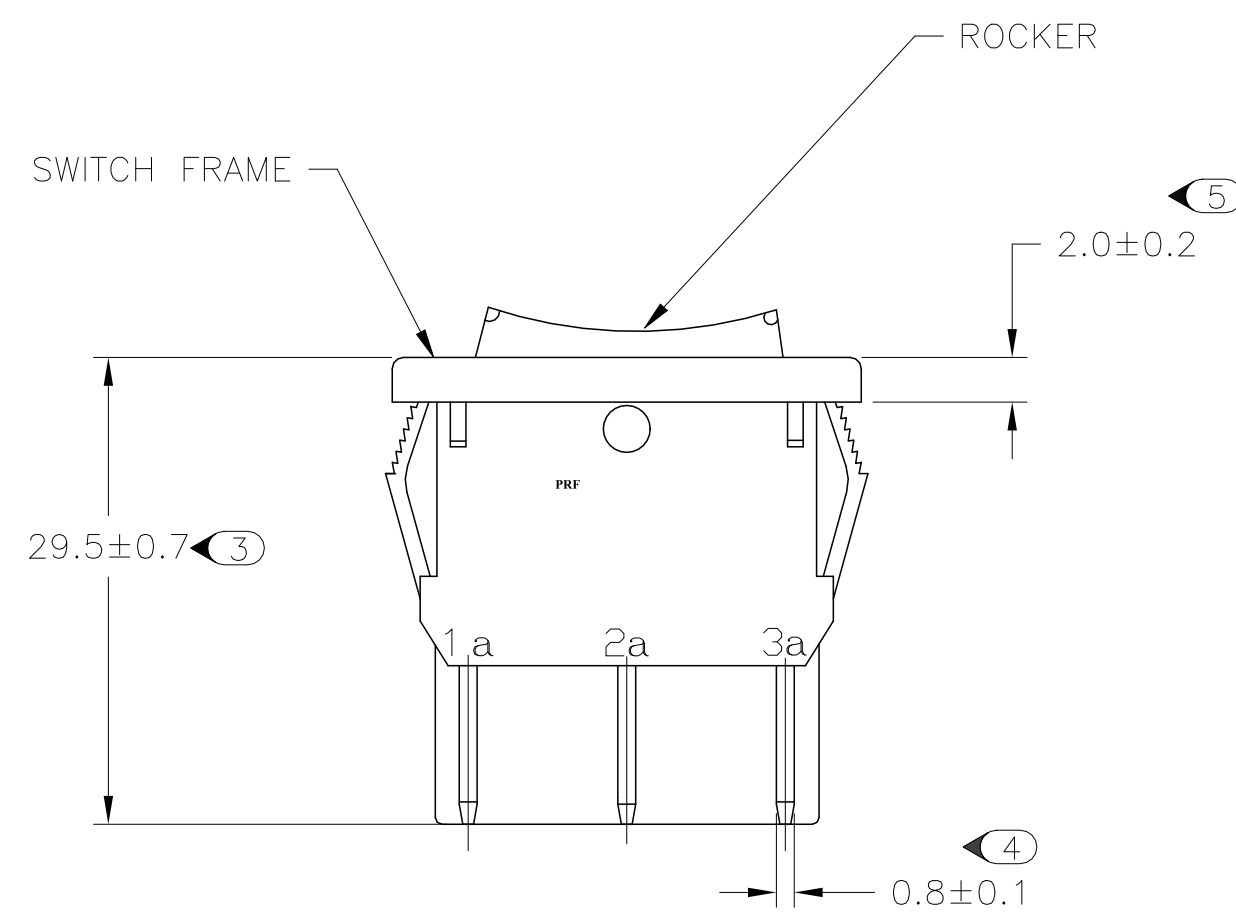

CIRCUIT DIAGRAM

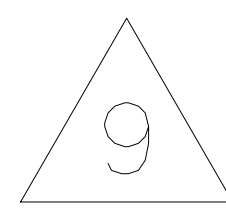
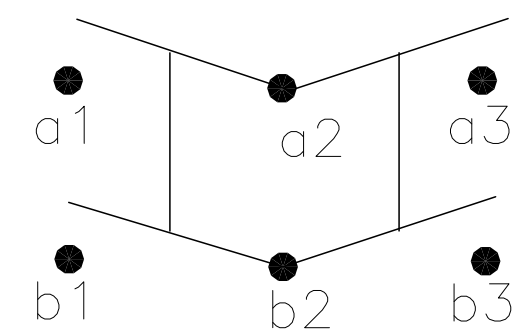

1-1634201-2 SHOWN ON-OFF-ON

THIS DRAWING IS A CONTROLLED DOCUMENT.		DWN S.SHACKSON 28JAN2003	TE Connectivity	
DIMENSIONS: MM		CHK H.KAUTZ 28JAN2003		
TOLERANCES UNLESS OTHERWISE SPECIFIED:		APVD H.KAUTZ 28JAN2003	NAME POWER ROCKER SWITCH, 30.2mm X 22.2mm PANEL SIZE, DPST, NON-ILLUMINATED	
0 PLC ± -		PRODUCT SPEC	SIZE A2	
1 PLC ± 0.5		APPLICATION SPEC	CAGE CODE 00779	
2 PLC ± -		NOT APPLICABLE	DRAWING NO 1634201	
3 PLC ± -		NOT APPLICABLE	RESTRICTED TO -	
4 PLC ± -		NOT APPLICABLE	SCALE 3:1	
ANGLES ± ± -		MATERIAL	SHEET 4 of 5	
FINISH		WEIGHT	REV G	
		CUSTOMER DRAWING		

REVISIONS					
P	LTR	DESCRIPTION	DATE	DWN	APVD
-	-	SEE SHEET 1	-	-	-

ALCOSWITCH PART NUMBER

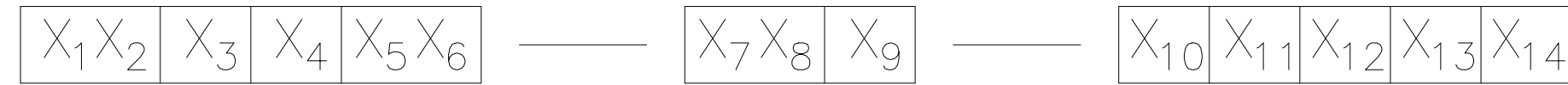

SWITCH TYPE: X₁X₂ = PR - POWER ROCKER

SECONDARY ROCKER COLOR: X₁₂ = ∅ - NOT APPLICABLE

NOMINAL PANEL CUT OUT SIZE: X₃ = F - 30.2X22.2 [.1.189x.874]

- B - BLACK
- G - GREEN
- R - RED
- W - WHITE

NUMBER OF POLES: X₄ = D - DOUBLE

SWITCH FUNCTION: X₅X₆ =

- A1 -
- B1 -
- D1 -
- D3 -

LEGEND TEXT PATTERN: X₁₃ =

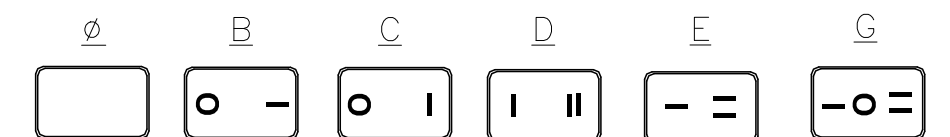

CURRENT RATING: X₇X₈ = 16 -

TERMINAL TYPE: X₉ = F - FASTON™ TAB

LEGEND TEXT COLOR: X₁₄ = ∅ - NOT APPLICABLE

FRAME COLOR: X₁₀ =

- B - BLACK
- W - WHITE

- G - GREEN
- R - RED
- B - BLACK
- W - WHITE

ROCKER COLOR: X₁₁ =

- B - BLACK
- G - GREEN
- R - RED
- Y - YELLOW

1 MATERIALS:
 HOUSING FRAME: NYLON 66.
 ACTUATOR: NYLON 66/ PC(ILLUMINATED)
 TERMINALS C1100R-1/2H WITH SILVER PLATED CONTACTS AgALLOY

2 FINISH:
 TERMINAL, ACTIVE CONTACTOR: 1.0µm [.000039] SILVER
 PLUNGER: 3.0mm[.000118] NICKEL

3 ELECTRICAL SPECIFICATIONS:
 CONTACT RESISTANCE : 50m ohm Max
 DIELECTRIC STRENGTH : AC 1500V, 1 MINUTE
 OPERATION TEMPERATURE: -20°C~85°C
 INSULATION R: DC 500V 100M ohm MIN

4 CURRENT AND VOLTAGE 16A@125VAC/10A@250VAC

5 ELECTRICAL RATINGS, APPROVED AGENCY LOGOS,
 TE LOGO PER TEC-202-36 APPROXIMATELY AS SHOWN
 AND PART NUMBER CAN APPEAR ON EITHER SIDE
 (FOR FULL DETAIL SEE INDIVIDUAL DRAWING)

6 ON-OFF, WITH OPAQUE, SINGLE-COLOR ROCKER BUTTON.

7 ON-OFF, WITH TRANSPARENT, LAMP-ILLUMINATED ROCKER BUTTON.

8 ON-ON, WITH OPAQUE, SINGLE-COLOR ROCKER BUTTON.

9 ON-OFF-ON, WITH OPAQUE, SINGLE-COLOR ROCKER BUTTON.

10 PACKAGING TO CONFORM WITH TYCO SPEC. 107-115

11 REFER TO QIP DIMENSIONAL REPORT

12 NOTE REMOVED.

13 PART NUMBER WITHOUT AGENCY APPROVAL, APPLY IT TO PN 1-1634201-0 AND 1-1634201-2.

	1	PRFDA1-16F-BB000	0-1634201-1
	1	PRFDA1-16F-BB0BW	0-1634201-2
	1	PRFDA1-16F-BB0CW	0-1634201-3
	2	PRFDB1-16F-BR000	0-1634201-4
	2	PRFDB1-16F-BG000	0-1634201-5
	2	PRFDB1-16F-BY000	0-1634201-6
	3	PRFDD1-16F-BB000	0-1634201-7
OBSOLETE	3	PRFDD1-16F-BB0DW	0-1634201-8
	3	PRFDD1-16F-BB0EW	0-1634201-9
	4	PRFDD3-16F-BB000	1-1634201-0
OBSOLETE	4	PRFDD3-16F-BB0EW	1-1634201-1
	4	PRFDD3-16F-BB0GW	1-1634201-2
	SHEET REF	ALCO SWITCH PART NUMBER.	TE PART NUMBER.

THIS DRAWING IS A CONTROLLED DOCUMENT.		DWN S.SHACKSON 28JAN2003	TE Connectivity	
DIMENSIONS: MM		CHK H.KAUTZ 28JAN2003		
TOLERANCES UNLESS OTHERWISE SPECIFIED:		APVD H.KAUTZ 28JAN2003	NAME POWER ROCKER SWITCH, 30.2mm X 22.2mm PANEL SIZE, DPST, NON-ILLUMINATED	
0 PLC ± -		PRODUCT SPEC	SIZE	
1 PLC ± 0.5		NOT APPLICABLE	CAGE CODE	
2 PLC ± -		APPLICATION SPEC	DRAWING NO	
3 PLC ± -		NOT APPLICABLE	RESTRICTED TO	
4 PLC ± -		NOT APPLICABLE	SCALE	
ANGLES ± -		WEIGHT	SHEET	
MATERIAL		FINISH	REV	
		CUSTOMER DRAWING	G	

1634201