

PART NUMBER	REV	FIRST USED	DESCRIPTION
1852157-1	A	122500-1	CUTS CARRIER
1852157-2	A	565435-5	CUTS CARRIER
1852157-3	A	354500-1	CUTS CARRIER
1852157-6	A	122500-1	CONTINUOUS CARRIER
7-1852157-7	A	354500-1	SPARE PARTS

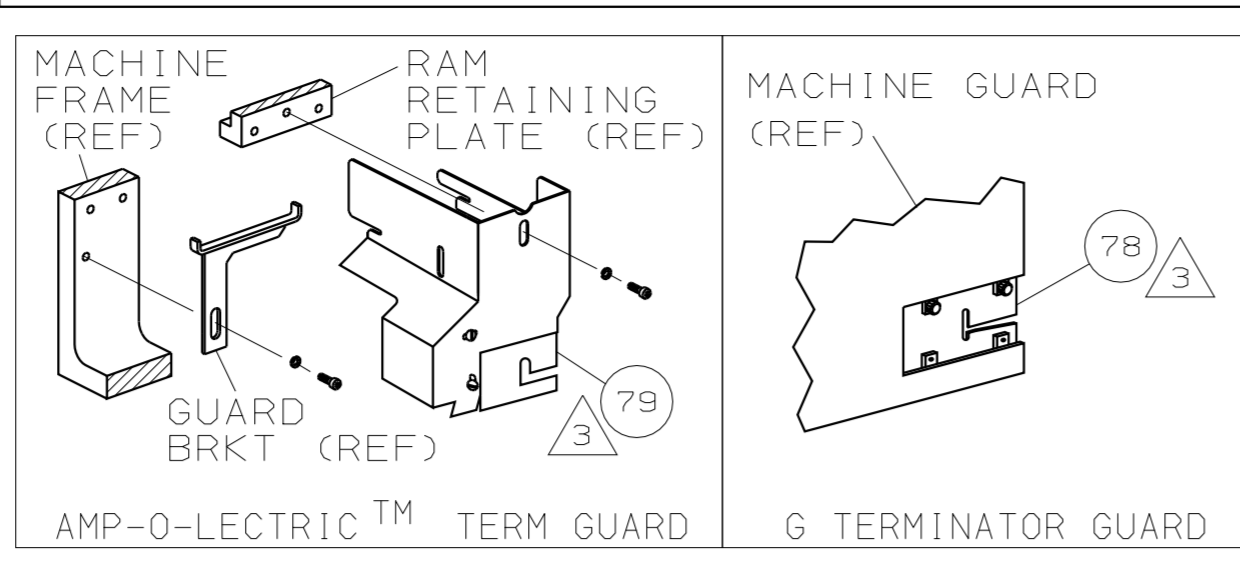

TERMINAL NAME: Micro-Match COSI CONTACT			
338096			
PAD LTR	CRIMP HEIGHT	WIRE SIZE	
A	.031 ±.002 [0.79 ±0.05mm]	24	
B	.029 ±.002 [0.74 ±0.05mm]	26	
C	.026 ±.002 [0.66 ±0.05mm]	28	
D	NOT	USED	
CRIMP	SIZE	TYPE	RANGE
WIRE	.042 [1.07mm]	F	28-24
INSUL	.055 [1.40mm]	0	∅.030-.040
WIRE STRIP LENGTH	TERM APPL SPEC	FEED	APPL INSTRUCTION
.098 [2.50]	114-19051	.236	408-8040
SET UP GAGE	LAYOUT		
458637-1	-		

-1	LEADMAKER	MECH POST FEED
-2	BENCH MODEL K	MECH PRE FEED
-3	BENCH MODEL G	MECH PRE FEED
-6	LEADMAKER	MECH POST FEED
-77	BENCH & LEADMAKER	SPARE PARTS

- 1 RECOMMENDED SPARE PARTS.
- 2 GREASE LIGHTLY.
- 3 GUARD MUST BE IN PLACE WHEN OPERATING APPLICATOR IN A BENCH MACHINE.
- 4 LUBRICATE DAILY USING NO. 20 MACHINE OIL.

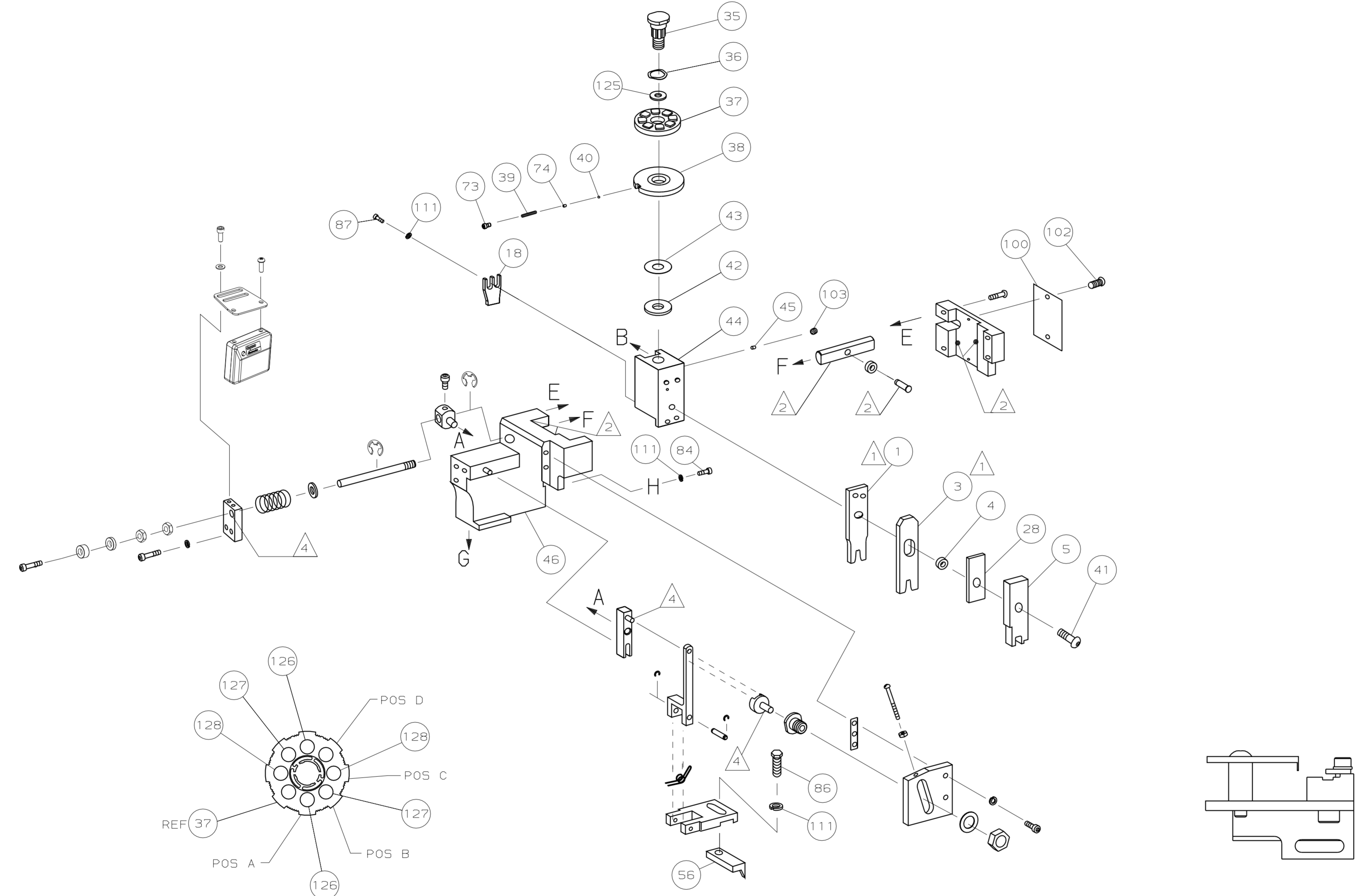

QTY	REQD	PER	ASSY	PART NO	DESCRIPTION	ITEM NO			
-	2	2	2	2	- C	4-354779-2	PIN, WIRE DISC (.3200)B	129	
-	2	2	2	2	- C	3-354779-4	PIN, WIRE DISC (.3160)B	127	
-	2	2	2	2	- C	3-354779-0	PIN, WIRE DISC (.3140)A	126	
-	1	1	1	1	- A	986950-1	WASHER, FLAT PRECISION	125	
-	1	1	1	1	- A	217238-1	GENERAL INSTRUCTION PACKAGE	124	
-	1	1	1	1	-	4088040	SF APPL INST 408-8040	123	
-	1	1	1	1	- A	21024-5	WASHER, LOCK (#10)ADJ BLOCK	117	
-	4	4	4	4	- A	21024-4	WASHER, LOCK (#8) STRIPPER	111	
-	1	1	1	1	- A	21009-2	SCR, SKT SET (1/4-20x.25 LW) RAM	103	
-	2	2	2	2	- A	21017-2	SCR, DRIVE (#2x.19) ID PLATE	102	
-	1	1	1	1	- B	461264-1	PLATE, IDENTIFICATION	100	
-	1	1	1	1	- A	22733-8	SCR, BHC (8-32x.38 LW) ANVIL	98	
-	2	2	2	2	- A	2-21002-2	SCR, BHC (8-32x.50) SHEAR HOLDER	94	
-	1	1	1	1	- A	1-21002-7	SCR, BHC (6-32x.38) CAM	91	
-	2	2	2	2	- A	2-21000-5	SCR, SHC (8-32x.25) TERM H DWN	87	
-	1	1	1	1	- A	2-22603-0	SCR, HEX HD (8-32x.31) FEED FINGER	86	
-	1	1	1	1	- A	2-21000-7	SCR, SHC (8-32x.50) STRIPPER	84	
-	1	1	1	1	- A	3-21000-4	SCR, SHC (10-32x.38) SG ADJ BL	81	
-	-	-	-	-	REF	-	GUARD, WINDOW	79	
-	-	-	-	-	REF	-	INSERT, GUARD	78	
-	1	1	1	1	- A	690603-1	SPRING, ASSIST	74	
-	1	1	1	1	- A	23030-1	SCR, SHC (6-32x.25 SL) INS DISC	73	
-	1	1	1	1	- B	458537-2	PAWL, FEED	56	
-	-	1	-	-	-	B	690602-6	CAM, PRE-FEED 1 5/8 ST	49
-	-	-	1	-	-	B	690602-5	CAM, PRE-FEED 1 1/8 ST	48
-	1	-	-	1	-	B	690501-4	CAM, POST-FEED 1 5/8 ST	47
-	1	1	1	1	- B	459456-1	APPLICATOR, BASIC (SUBASSY)	46	
-	1	1	1	1	- A	690191-1	PLUG, NYLON	45	
-	1	1	1	1	- C	455673-3	RAM	44	
-	1	1	1	1	- A	690125-1	WASHER, LAMINATED	43	
-	1	1	1	1	- A	690124-9	WASHER, RAM	42	
-	1	1	1	1	- A	7-21002-9	BOLT, CRIMPER (5/16x1.00)	41	
-	1	1	1	1	- A	23241-6	BALL, STEEL	40	
-	1	1	1	1	- A	690170-1	SPRING, COMPRESSION	39	
-	1	1	1	1	- C	690142-5	DISC, INSULATION	38	
-	1	1	1	1	- D	354777-1	DISC, WIRE	37	
-	1	1	1	1	- A	22480-5	WASHER, SPRING	36	
-	1	1	1	1	- B	690212-1	POST, RAM	35	
-	2	2	2	2	- A	2-21002-3	SCREW, BHC (8-32x.62)	33	
-	1	1	1	1	- A2	1320908-9	SPACER, STRIP GUIDE	30	
-	1	1	1	1	- A1	1633091-1	SUB-ASSY, FEEDTRACK	29	
-	1	1	1	1	- C	455888-1	SPACER, FRONT SHEAR DEP	28	
-	1	1	1	1	- A2	1320928-1	PLATE, STRIP GUIDE	24	
-	1	1	1	1	- B	690472-8	STRIPPER	22	
-	1	1	1	1	- B	1-690518-1	HOLDER, TERMINAL	18	
-	1	-	-	-	-	C	679625-1	HOLDER, SHEAR (FRONT)	17
-	1	1	1	1	- B	318563-1	GUARD, CHIP, FRONT	16	
-	1	1	1	1	- A	3-22280-3	SPRING, SHEAR	12	
-	1	1	1	1	- B	690461-1	STOP, SHEAR	11	
-	-	1	1	1	- C	690459-1	HOLDER, SHEAR (FRONT)	10	
1	1	1	1	1	- C	462006-1	SHEAR, FLOAT (FRONT)	9	
1	1	1	1	1	- C	1-662182-8	ANVIL	8	
-	1	1	1	1	- C	2-455889-0	DEPRESSOR, SHEAR (FRONT)	5	
-	1	1	1	1	- B	1-238011-6	SPACER, BLOCK CRIMPER	4	
1	1	1	1	1	- C	5-683454-9	CRIMPER, INSULATION	3	
1	1	1	1	1	- C	3-456401-0	CRIMPER, WIRE	1	

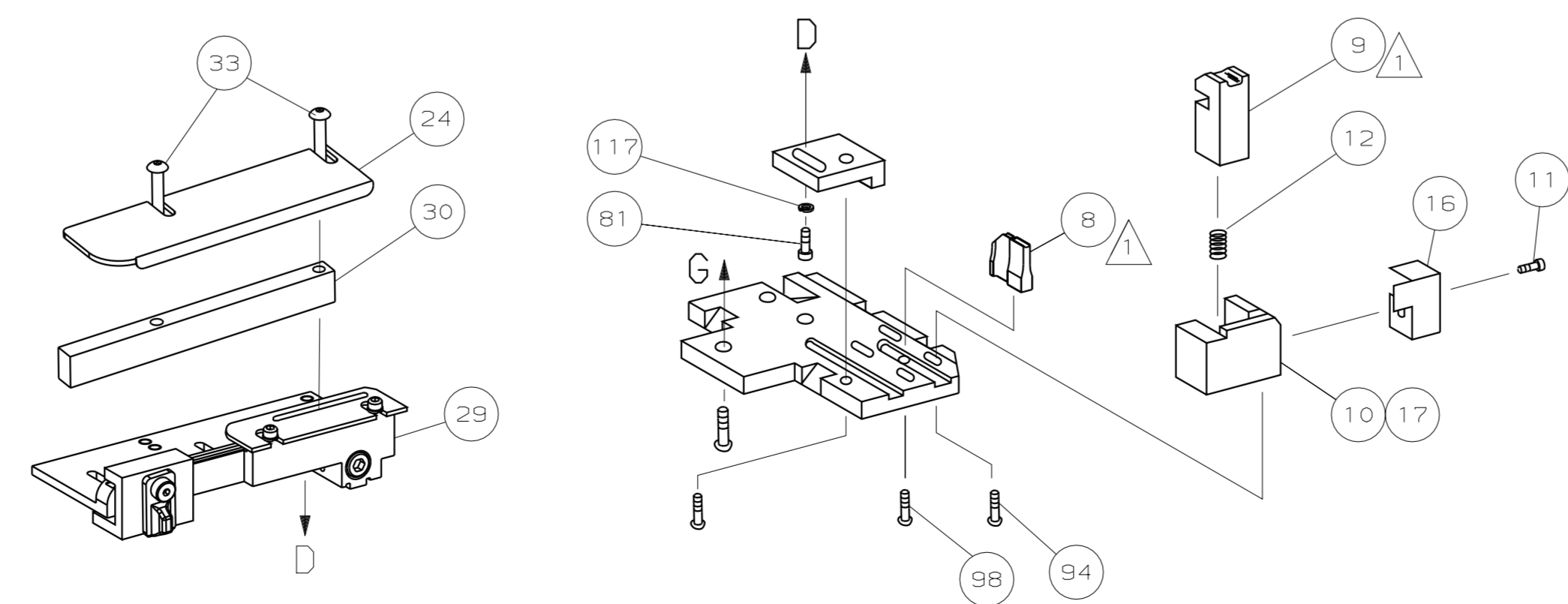
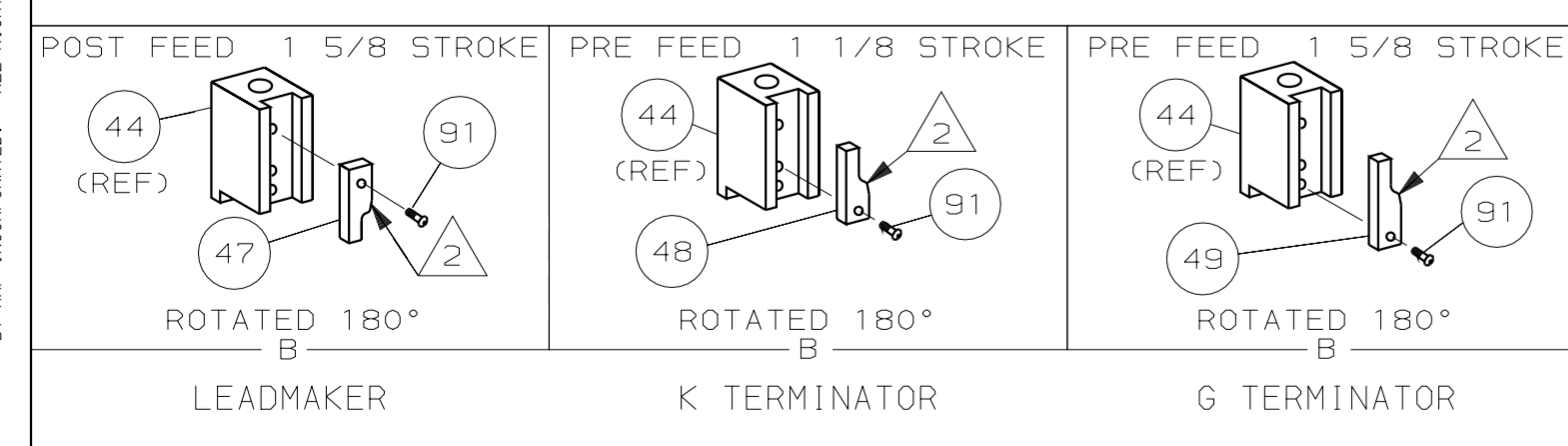

LOC	DIST	REV	DATE	BY	CHK	APP	DATE	REVISION
A	66							

SCALE	DWG NO	REV
-	1852157	A

DIMENSIONS IN INCHES. DO NOT SCALE PRINT. TOLERANCES UNLESS OTHERWISE SPECIFIED:		MATERIAL		FINISH	
1	PLC DEC ±.02	DR	11NOV05	HT TR	-
2	PLC DEC ±.02	R.O.WILSON	T.ELBIN	FIN	-
3	PLC DEC ±.02	CHK	11NOV05		
4	PLC DEC ±.02	R.O.WILSON			
ANGLES ± -		AMP Tyco Electronics Harrisburg, PA 17105-3608			
SURF TEXTURE: ✓		NAME SIDE FEED HDM APPLICATOR MACHINE REF MINI APPL			
REMOVE BURRS, BREAK SHARP EDGES R.015 MAX		SCALE - DWG NO 1852157 SHEET 1 OF 1 REV A			

THIS DRAWING IS A CONTROLLED DOCUMENT.

20

THIS DRAWING IS UNRELEASABLE. RELEASE FOR PUBLICATION BY AMP INCORPORATED. ALL RIGHTS RESERVED. COPYRIGHT 20

1852157

D

C

B

A